

Eco-Choice WS Series Wood Burner Installation Instructions

**Model:
WS18-AU**

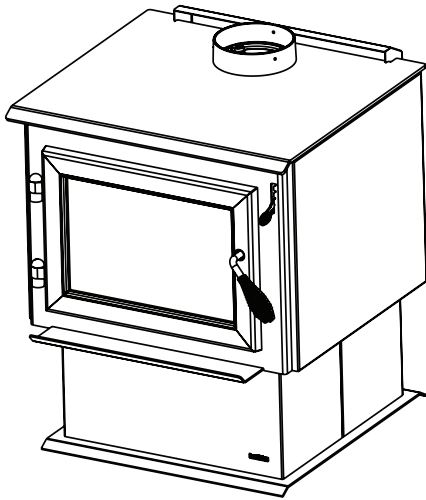

**Model:
WS22-AU**

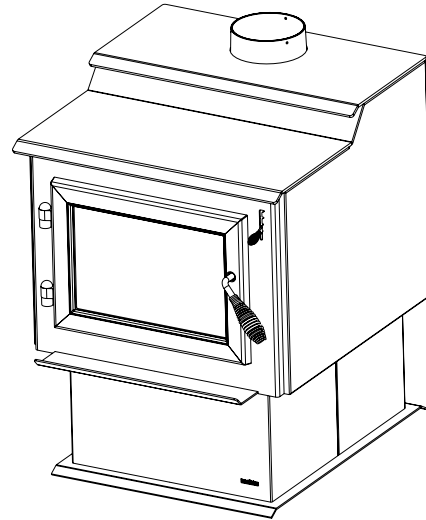

INSTALLATIONS TO COMPLY WITH AS/NZS2918:2001
AND WILL REQUIRE A BUILDING CONSENT

IMPORTANT: Read all instructions carefully before starting installation. Failure to follow these instructions may result in a fire hazard and will void the warranty.

- Fig. 3,4,5,6, 7 and Table 1,2,3,4 relate to installations with tested flue systems; as per **AS/NZS 2918:2001 - Appendix F**, with a ceiling angle between 0° - 30° inclusive.
- For installations with a ceiling angle greater than 30°, refer to Fig. 7 & 8 and **AS/NZS 2918:2001 4.6.3(b)**
- Ceiling Plate may vary in size depending on ceiling angle. Please specify ceiling pitch prior to ordering the ceiling plate.
- Heatilator Eco Choice series wood burner's are tested and approved to the N.Z. National Environmental Standards;

WS18-AU Eco-Choice Hardwood Certified
Particulate Emissions = 1.3 g/kg Space Heating Efficiency = 85%

WS22-AU Eco-Choice Hardwood Certified
Particulate Emissions = 1.2 g/kg Space Heating Efficiency = 82%

Congratulations

Hearth & Home Technologies welcomes you to our tradition of excellence! In choosing a Heatilator appliance, you have our assurance of commitment to quality, durability, and performance.

This commitment begins with our research of the market, including 'Voice of the Customer' contacts, ensuring we make products that will satisfy your needs. Our Research and Development facility then employs the world's most advanced technology to achieve the optimum operation of

our stoves, inserts and fireplaces. And yet we are old-fashioned when it comes to craftsmanship. Each unit is meticulously fabricated and surfaces are hand-finished for lasting beauty and enjoyment. Our pledge to quality is completed as each model undergoes a quality control inspection.

We wish you and your family many years of enjoyment in the warmth and comfort of your hearth appliance. Thank you for choosing Heatilator.



ECO CHOICE WOODFIRE COMPLIANCE LABEL

This appliance has been TESTED TO AS/NZS4013 for Hardwood by HRL Technology Report # HCMG/14/004 Date tested: February 2014

MODEL	ECO CHOICE WS18 WOOD STOVE
OVERALL AVERAGE EFFICIENCY <small>TESTED TO AS/NZS 4012</small>	HARDWOOD 85%
AVERAGE PARTICULATE EMISSION FACTOR <small>TESTED TO AS/NZS 4013</small>	1.3 g/kg
MAXIMUM AVERAGE HEAT OUTPUT	7.2 kW
APPROVED FUEL	BURN ONLY WOOD WITH A MOISTURE CONTENT LESS THEN 25% (dry basis).
WETBACK - ALL MODELS MANUFACTURED BY	Wetbacks are NOT an approved option and must not be fitted. Hearth & Home Technologies, 1445 North Highway, Colville, WA 99114, United States of America.

SERIAL NO.
007065

JAN FEB MAR APR MAY JUN JUL AUG SEP OCT NOV DEC
 2014 2015 2016

NOTE: PERFORMANCE MAY VARY FROM TEST VALUES DEPENDING ON ACTUAL OPERATING CONDITIONS.

U.S. ENVIRONMENTAL PROTECTION AGENCY
Export stove. May not be operated within the United States.

INSTALLATION DATE _____ / _____ / _____ 7056-154



ECO CHOICE WOODFIRE COMPLIANCE LABEL

This appliance has been TESTED TO AS/NZS4013 for Hardwood by HRL Technology Report # HCMG/14/006 Date tested: February 2014

MODEL	ECO CHOICE WS22 WOOD STOVE
OVERALL AVERAGE EFFICIENCY <small>TESTED TO AS/NZS 4012</small>	HARDWOOD 82%
AVERAGE PARTICULATE EMISSION FACTOR <small>TESTED TO AS/NZS 4013</small>	1.2g/kg
MAXIMUM AVERAGE HEAT OUTPUT	9.4 kW
APPROVED FUEL	BURN ONLY WOOD WITH A MOISTURE CONTENT LESS THEN 25% (dry basis).
WETBACK - ALL MODELS MANUFACTURED BY	Wetbacks are NOT an approved option and must not be fitted. Hearth & Home Technologies, 1445 North Highway, Colville, WA 99114, United States of America.

SERIAL NO.
007066

JAN FEB MAR APR MAY JUN JUL AUG SEP OCT NOV DEC
 2014 2015 2016

NOTE: PERFORMANCE MAY VARY FROM TEST VALUES DEPENDING ON ACTUAL OPERATING CONDITIONS.

U.S. ENVIRONMENTAL PROTECTION AGENCY
Export stove. May not be operated within the United States.

INSTALLATION DATE _____ / _____ / _____ 7057-139

Heatilator WS18 Wood Burner Dimensions

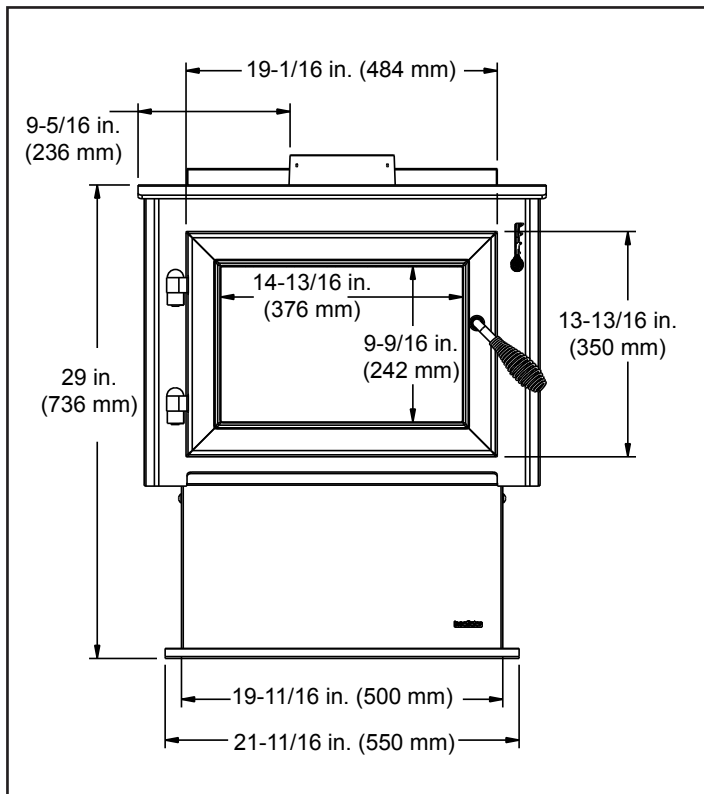

Figure 3.1 - Front View

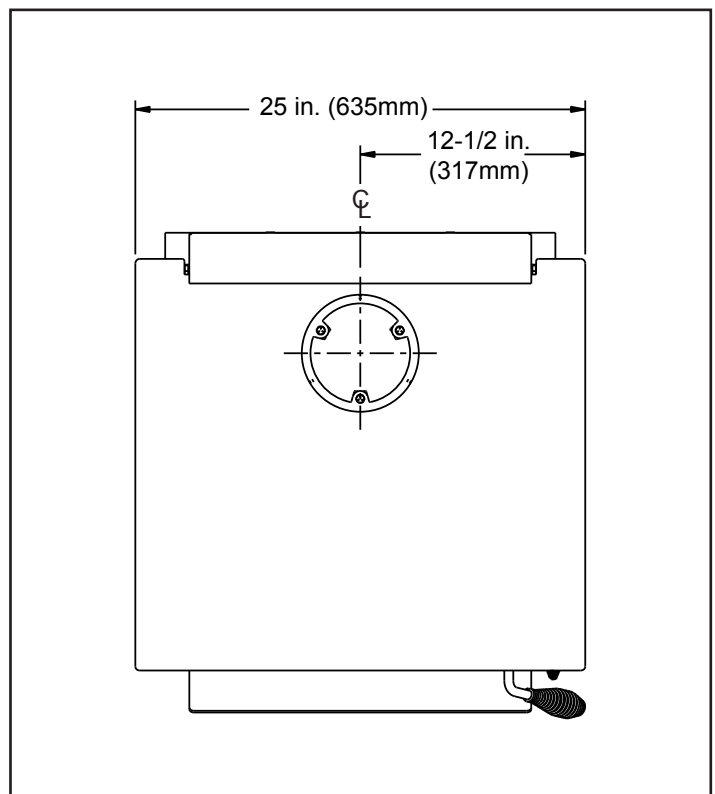

Figure 3.2 - Top View

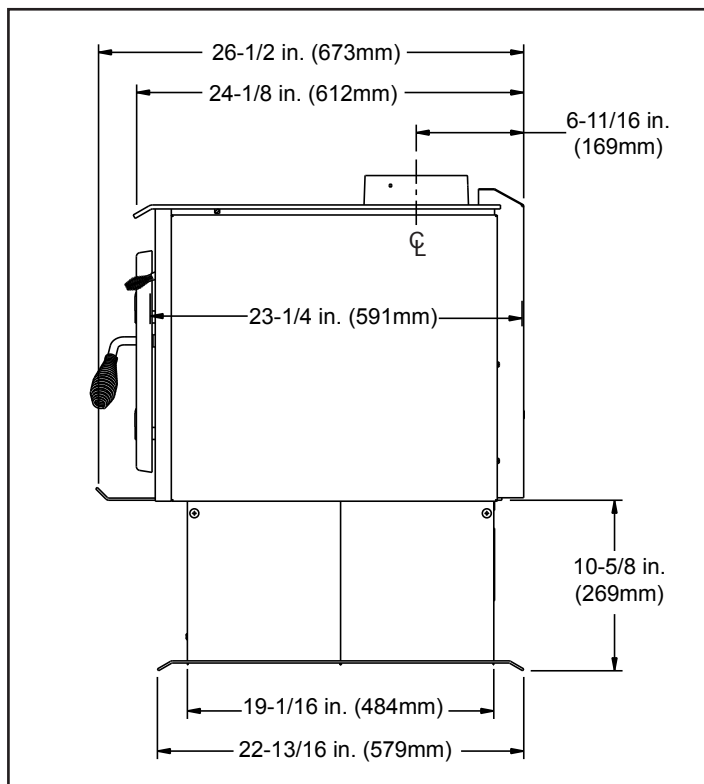

Figure 3.3 - Side View

FLOOR PROTECTOR

Heatilator WS18 does not require a insulating Floor Protector, as they are tested and comply with the minimum Floor Protector requirements of **AS/NZS 2918:2001**.

Note:

- The minimum Floor Protector sizes are specified in the clearance chart, see Table 1 & 2.
- A Floor Protector can include ceramic tiles with grouted joints fixed directly onto a wooden floor or a sheet of toughened glass, panel steel or any other non combustible material laid directly onto a wooden floor.
- If installed directly onto a concrete slab, the concrete slab can be considered as the floor protector, but must maintain the minimum measurement listed.

PARALLEL POSITIONING

Fig. 3

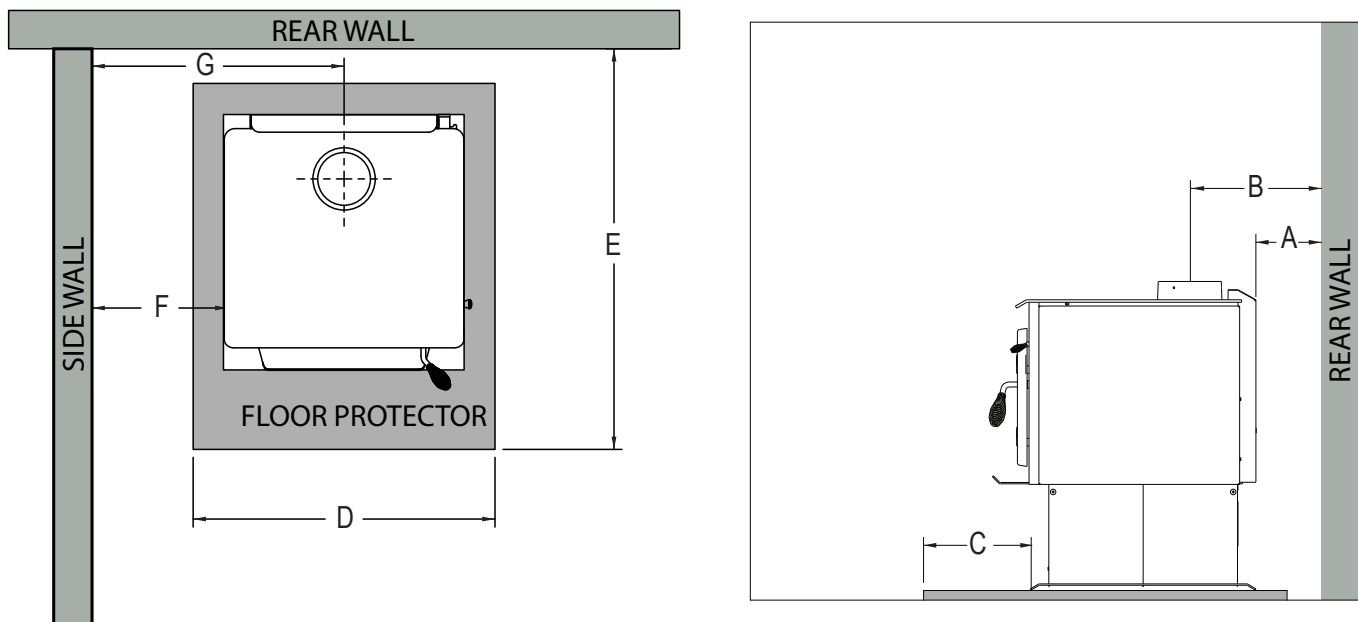

Table 1

	DESCRIPTION	Default Flue Kit
A	Min. Clearance from back of unit to rear wall	175
B	Min. clearance from center of spigot to rear wall	345
C	Min. distance from front of base to floor protector front	300
D	Min. floor protector front width	800
E	Min. distance from rear wall to front of floor protector	1055
F	Min. distance from unit side to side wall	300
G	Min. clearance from center of spigot to side wall	618

NOTE: HEAT SHIELD REQUIREMENTS FOR HEAT SENSITIVE WALLS

Clearances may be reduced by provision of an appropriately located heat shield refer to **AS/NZS 2198:2001 3.2.3 TABLE 3.1**

CORNER POSITIONING (45°)

Fig. 4

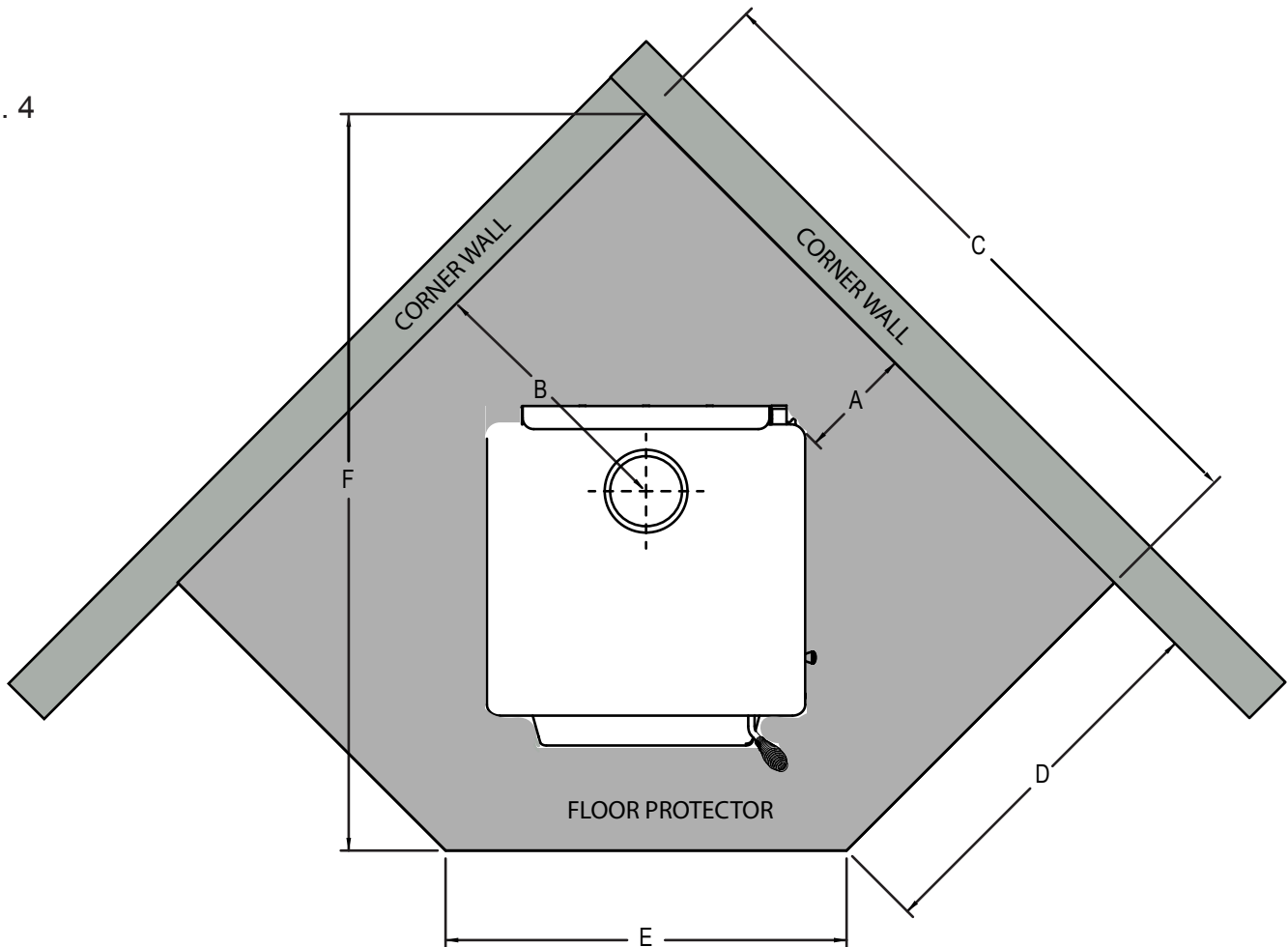

Table 2

	DESCRIPTION	Default Flue Kit
A	Min. clearance from firebox corner to corner walls	155
B	Min. distance from center of spigot to corner walls	470
C	Min. distance from corner wall to floor protector front	1219
D	Min. floor protector projection from corner wall	730
E	Min. floor protector front width	692
F	Min. overall floor protector depth	1379

FIREBOX INSTALLATION

1. If a separate floor protector is being used position now. Place the firebox on the floor protector to suit the minimum installation clearances. (See Fig 3 or 4).
2. Seismically restrain the firebox and the floor protector to the floor.
3. Fit 2 x 6mm fixings suitable for the floor material. DO NOT over tighten.
4. Fit timber trim pedestal edging to front and back of base (optional).

Heatilator WS22 Wood Burner Dimensions

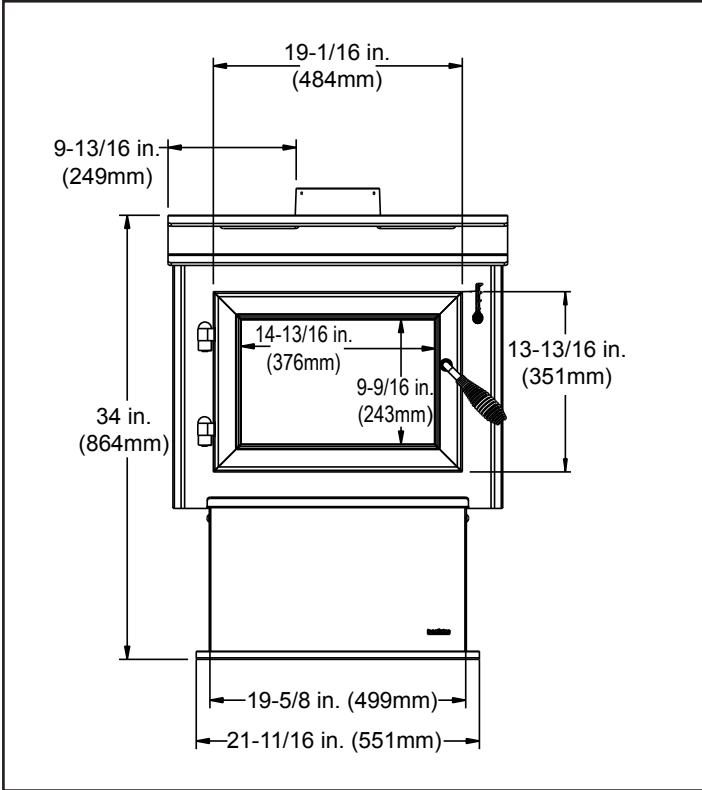

Figure 29.1 - Front View

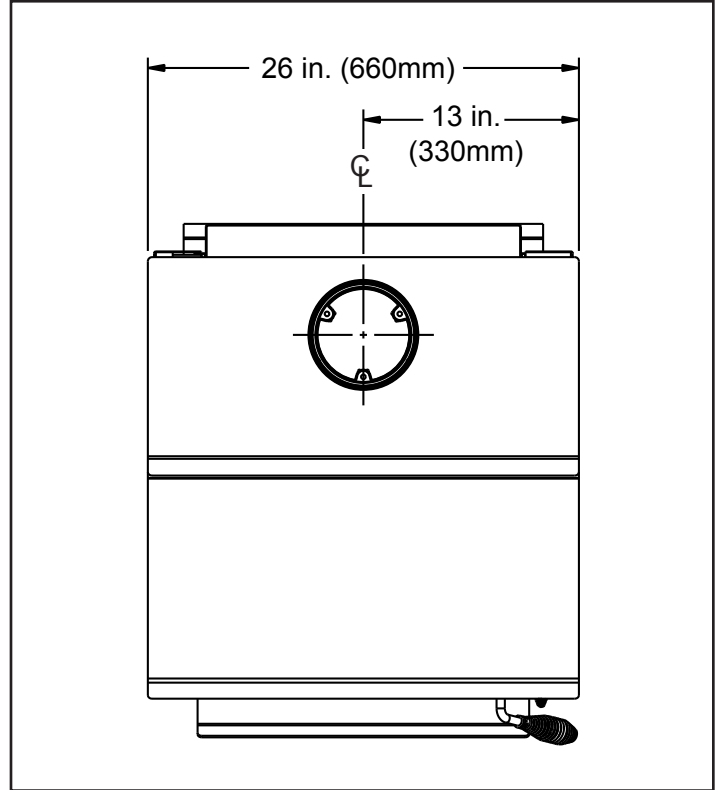

Figure 29.2 - Top View

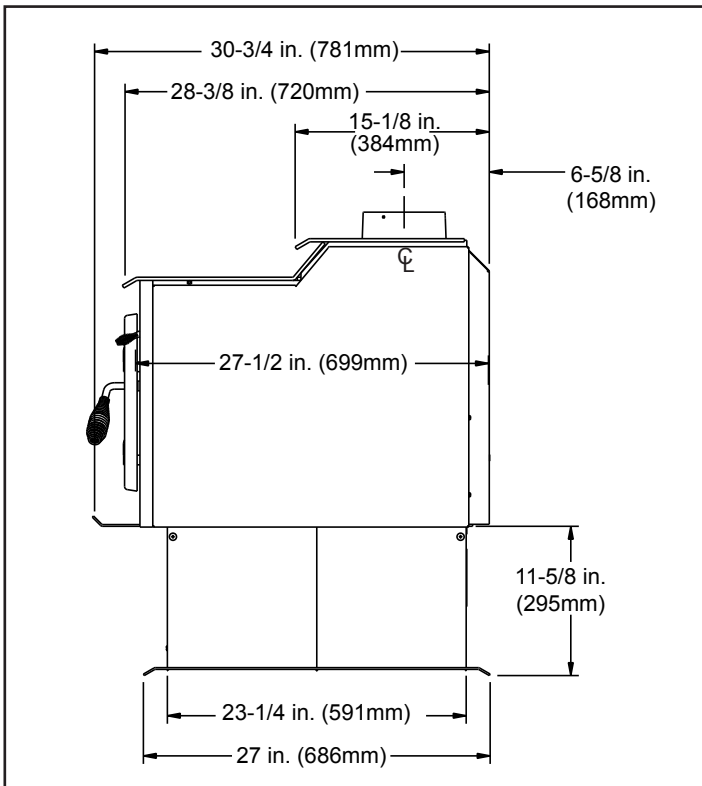

Figure 29.3 - Side View

FLOOR PROTECTOR

Heatilator WS22 does not require a insulating Floor Protector, as they are tested and comply with the minimum Floor Protector requirements of **AS/NZS 2918:2001**.

Note:

- The minimum Floor Protector sizes are specified in the clearance chart, see Table 3 & 4.
- A Floor Protector can include ceramic tiles with grouted joints fixed directly onto a wooden floor or a sheet of toughened glass, panel steel or any other non combustible material laid directly onto a wooden floor.
- If installed directly onto a concrete slab, the concrete slab can be considered as the floor protector, but must maintain the minimum measurement listed.

PARALLEL POSITIONING

Fig. 5

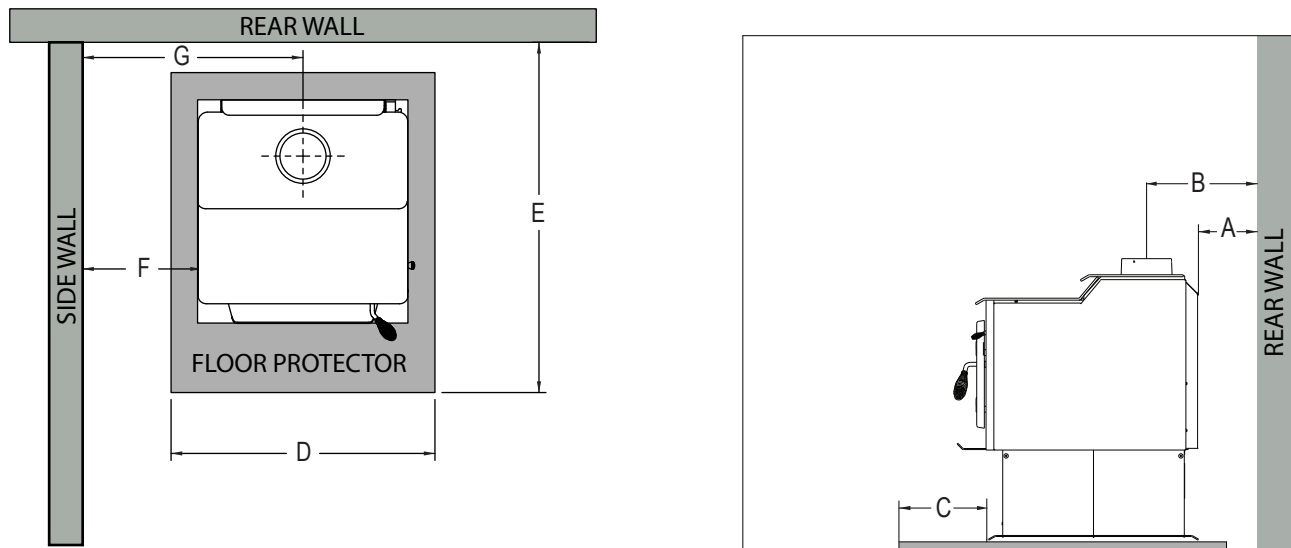

Table 3

	DESCRIPTION	Default Flue Kit	Default Flue Kit- With Flue Shield
A	Min. Clearance from back of unit to rear wall	300	100
B	Min. clearance from center of spigot to rear wall	468	268
C	Min. distance from front of base to floor protector front	300	300
D	Min. floor protector front width	800	800
E	Min. distance from rear wall to front of floor protector	1291	1091
F	Min. distance from unit side to side wall	400	400
G	Min. clearance from center of spigot to side wall	730	730

NOTE: HEAT SHIELD REQUIREMENTS FOR HEAT SENSITIVE WALLS

Clearances may be reduced by provision of an appropriately located heat shield refer to **AS/NZS 2198:2001 3.2.3 TABLE 3.1**

CORNER POSITIONING (45°)

Fig. 6

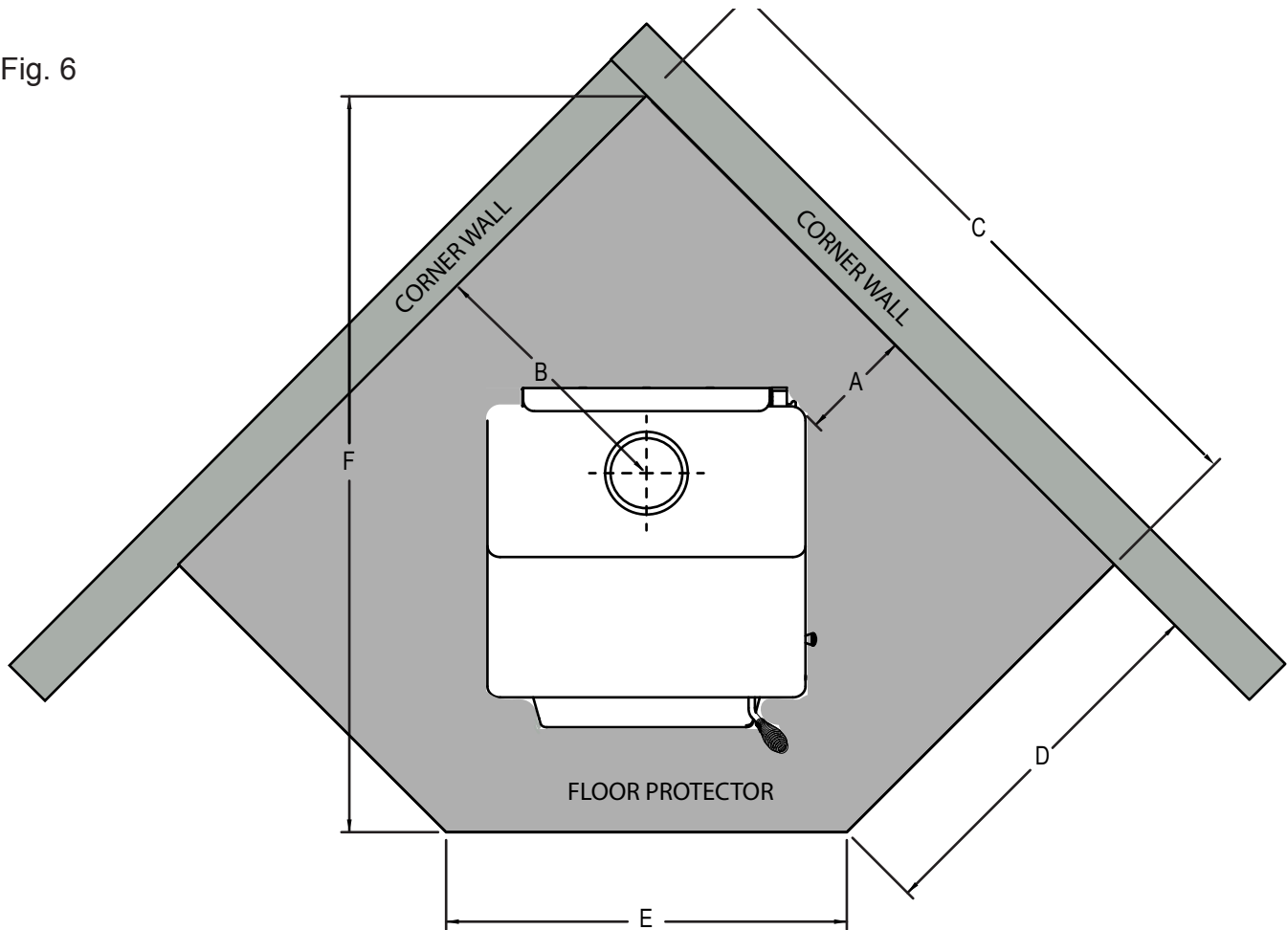

Table 4

	DESCRIPTION	Default Flue Kit
A	Min. clearance from firebox corner to corner walls	75
B	Min. distance from center of spigot to corner walls	393
C	Min. distance from corner wall to floor protector front	1217
D	Min. floor protector projection from corner wall	731
E	Min. floor protector front width	688
F	Min. overall floor protector depth	1377

FIREBOX INSTALLATION

1. If a separate floor protector is being used position now. Place the firebox on the floor protector to suit the minimum installation clearances. (See Fig 5 or 6).
2. Seismically restrain the firebox and the floor protector to the floor.
3. Fit 2 x 6mm fixings suitable for the floor material. DO NOT over tighten.
4. Fit timber trim pedestal edging to front and back of base (optional).

GENERAL INSTRUCTIONS FOR FLUE SYSTEM

- Flue pipe installed crimp/narrow end down
- Outer casings installed crimped/narrow end up. (Critical when exposed above the roof)
- Inner casings - direction not critical
- Flue pipes - seal all joints including firebox spigot.
- fix with a minimum of 3 stainless steel rivets
- Flue pipe spacers - affix to flue pipe
- Flue system termination point - Refer to AS/NZS 2918:2001 4.9.1, see Fig. 9.
- Flue pipe shall extend not less than 4.6m above top of the floor protector as per AS/NZS 2918:2001 4.9.1(a)
- Façade or chase systems - same rule applies as above.
- Roof penetration and flashing method refer to NZ Building Code E2.(From 01/07/05)

Note: These instructions apply to 150mm diameter flue pipe systems as tested to AS/NZS 2918:2001

1. Either locate the appliance in position or by measuring at the ceiling mark the flue pipe centre position. Check that the outer casing is unobstructed through the attic space or roof area.
2. Spike the centre with a nail. Transfer this position to the next surface above. Plumb bob/laser.
3. Cut out the ceiling penetration hole – square or rectangle – short axis equals outer casing diameter plus 50mm, long axis as required. See Table 5 . Perform the same at the roof penetration.
4. Frame out the hole with minimum 75 x 50 timber or as required for roofing material. Minimum requirement at roof penetration see NZ Building Code E2 Acceptable Solution (from 01/07/05).
5. Install the outer casing so that :-
 - (i) lower end is flush with the underside of the ceiling material and
 - (ii) with the addition of metal “L” brackets, affix to the outer casing at 90 degrees secure the outer casing centrally to the ceiling and roof nogs. Alternatively substitute the “L” brackets for 25mm thick non heat sensitive packers. Secure the outer casing through the packers with horizontal fixings to the nogs. Refer to the General Instruction for termination height. The option of outer casing slips to be taken into account.
6. Flash the outer casing to the roof material with the appropriate approved flashing.
7. If using an outer/inner casing combination, now install the inner casing ensuring it extends a minimum 200mm above the high side of the roof penetration. If not using a combination see ‘11’ below.
8. Refer to Firebox Installation, points 1 & 2.
9. Prepare the ceiling plate and place upside down over the flue spigot.
10. Install the flue pipes by preferred method – either up or down the outer casing. Affix each length per the notes in General Instructions (above). Extend the flue pipe above the outer casing to suit the casing cover/cowl assembly.
11. If the inner casing has not been installed, install now. Refer to 7 above for minimum height.
12. Install the cowl assembly, i.e. Top spacer, casing cover and cowl.
13. Position and secure the ceiling plate with the screws and spacers.
14. Wipe the flue pipe to remove finger marks.
15. Refer to Firebox Installation, point 3.
16. If flue offset is required, refer to AS/NZS 2918:2001 4.1

FLUE PENETRATION

Tested flue systems, as per AS/NZS 2918:2001

Fig. 7

Drawing not to scale

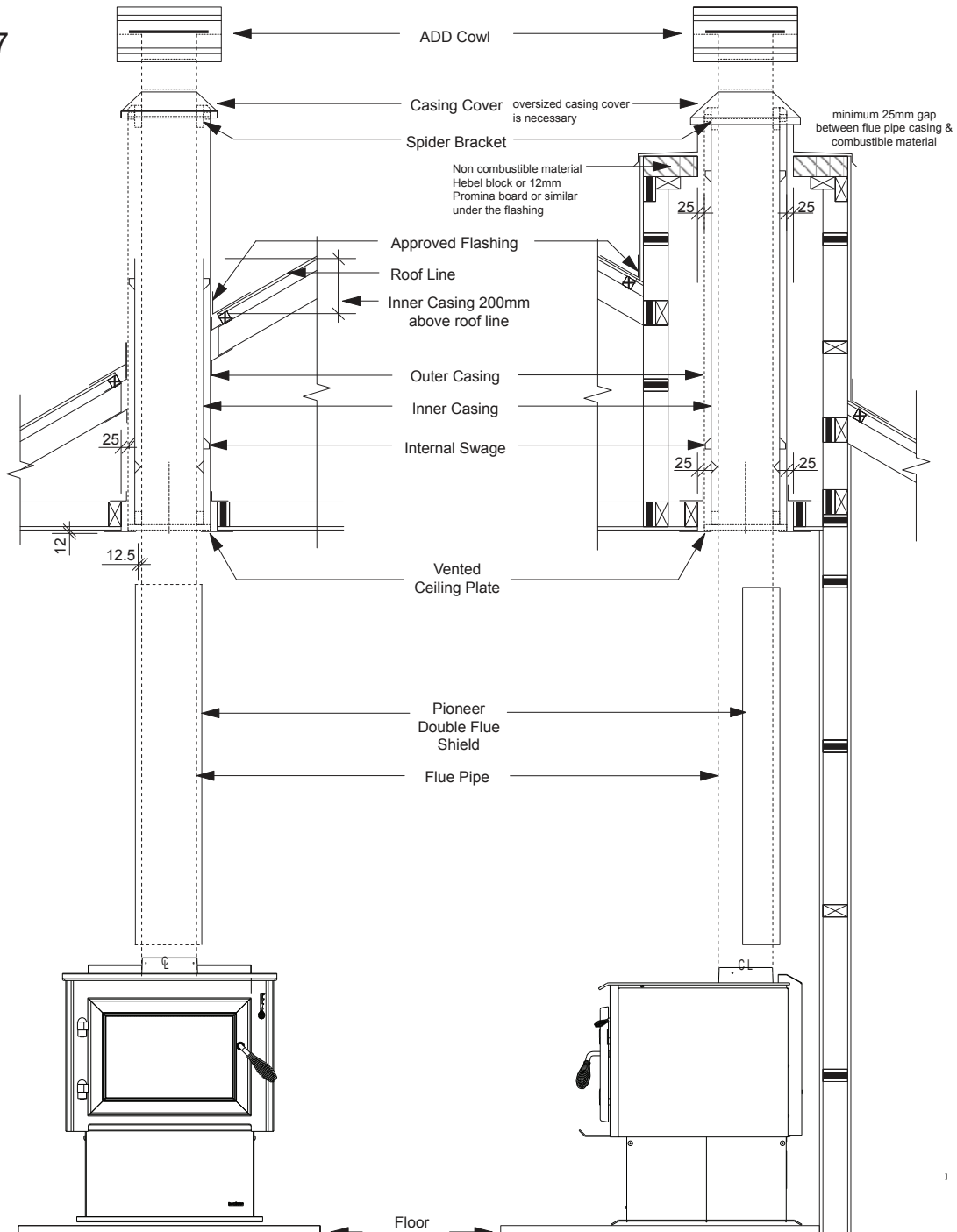

PLEASE NOTE:

The flue crimp must be cut so the swage (half-moon bulge after the crimp) fits tightly into the spigot.

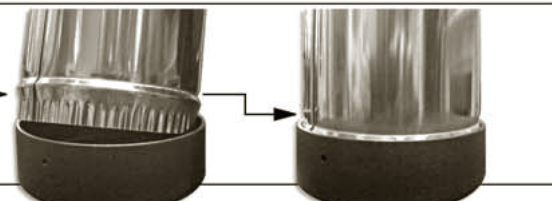

Un-tested flue systems, as per AS/NZS 2918:2001, 4.6.3(b)

Fig. 8

AS/NZS2918:2001

Un-tested flue with sloped ceiling penetration greater than 30° from horizontal

A = 25mm

4.6.3(b)

Fig 4.6 = downward distance of casing and 3 x Ø flue distance of the ceiling plate

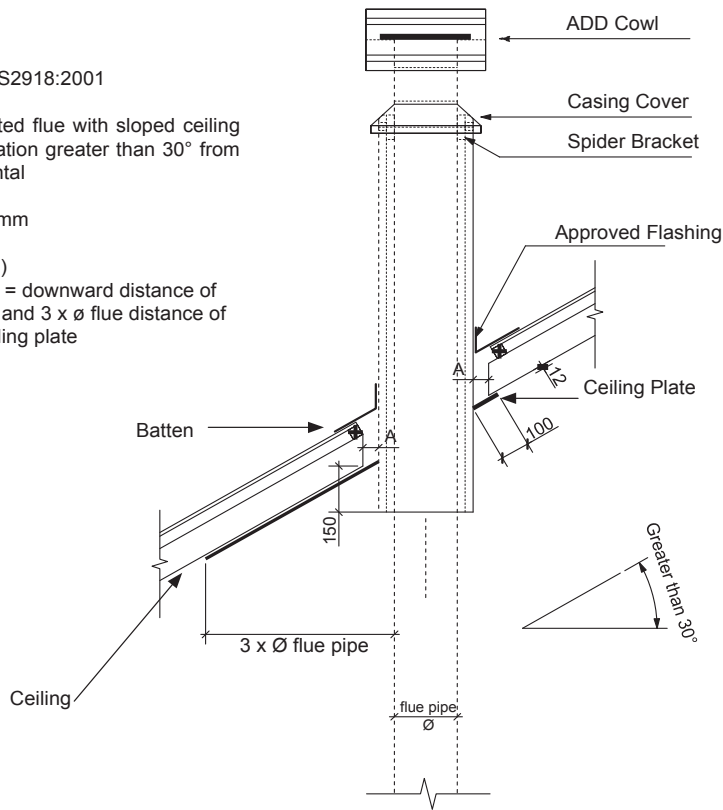

Fig. 9

AS/NZS2918:2001

Un-tested flue with sloped ceiling penetration greater than 30° from horizontal

A = 25mm

4.6.3(b)

Fig 4.6 = 3 x Ø flue from active flue to heat sensitive surface

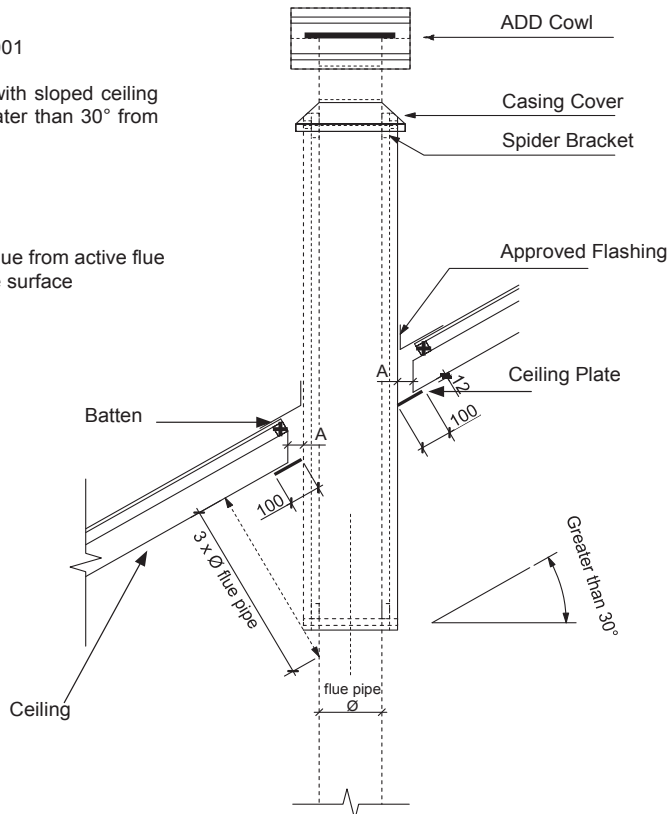

GENERAL INSTRUCTIONS FOR FLUE SYSTEM

1. Unpack the Flue Mounted Shield, detach the three brackets and familiarize yourself with the illustrations.
2. Using a sharp knife or razor blade, carefully cut through the plastic film on the “inside face” where it meets the outer shield (refer sketch). Cut along the full length of the Flue Mounted Shield on both side, then peel off and fully remove the plastic film from the stainless steel inner shield.
3. Peel back and fully remove the plastic film from the outer shield.
4. Fit the top bracket to the Flue Mounted Shield as illustrated ensuring the rear mid section of the bracket fits “outside” while the two outer sections of the bracket fit “inside”.
5. Fit the appropriate lower bracket to your woodfire.

Lower Bracket “5B suitable for all other woodfires without an inner rear heatshield. On certain model woodfires without a raised flue spigot it will be necessary to cut off both the lower outer legs from the bracket “5B” leaving the entral tongue to locate inside the flue outlet only.

Two tabs are provided and if folded back at 90 degrees the bracket and Flue Mounted Shield will mount lower onto the appliance.

The Flue Mounted Shield then locates into the two notches provided n bracket “5B” as illustrated.

6. Once the Flue Mounted Shield is fitted in position onto either of the two lower mounting brackets, check to ensure a large gap is not present between the top of the woodfire and the base of the Flue Mounted Shield, as this may result in a hot spot on the rear wall directly behind the flue outlet. If your woodfire has a lift off top grill the Flue Mounted Shield should be raised sufficiently to enable the top grill to be removed.

7. Using the pre-punched holes in the two tabs provided on the top bracket as guides, drill into the flue pipe and secure the top bracket to the flue pipe with two stainless steel rivets (not supplied).

MINIMUM HEIGHT OF FLUE SYSTEM EXIT

Fig. 10

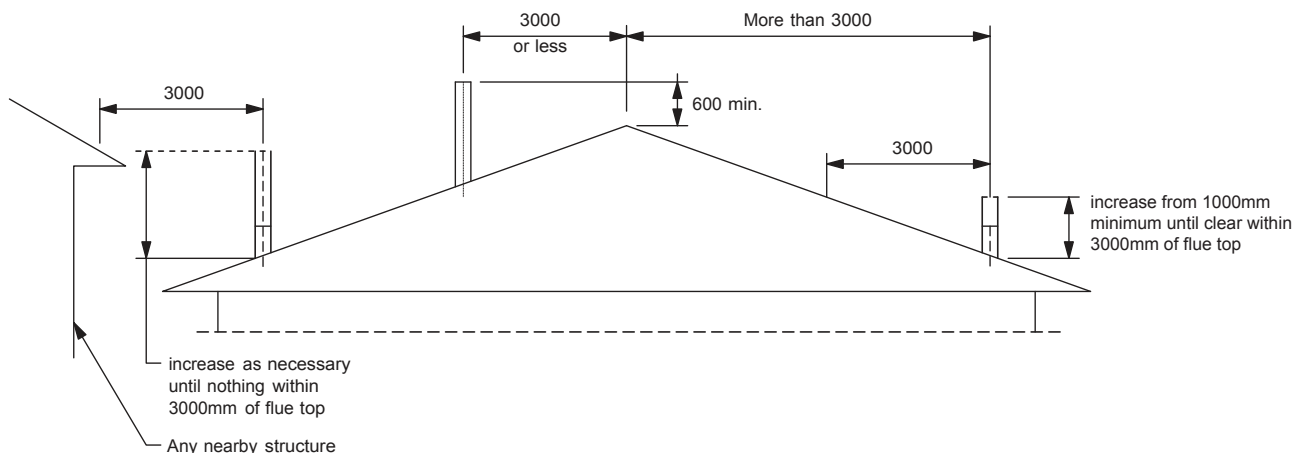

AS/NZS 2918:2001 GENERAL NOTES**WARNINGS:**

WARNING: THE APPLIANCE AND FLUE SYSTEM SHALL BE INSTALLED IN ACCORDANCE WITH AS/NZS 2918 AND THE APPROPRIATE REQUIREMENTS OF THE RELEVANT BUILDING CODE OR CODES.

WARNING: APPLIANCES INSTALLED IN ACCORDANCE WITH THIS STANDARD SHALL COMPLY WITH THE REQUIREMENTS OF AS/NZS 4013 WHERE REQUIRED BY THE REGULATORY AUTHORITY, I.E. THE APPLIANCE SHALL BE IDENTIFIABLE BY A COMPLIANCE PLATE WITH THE MARKING 'TESTED TO AS/NZS 4013'.

ANY MODIFICATION OF THE APPLIANCE THAT HAS NOT BEEN APPROVED IN WRITING BY THE TESTING AUTHORITY IS CONSIDERED TO BE IN BREACH OF THE APPROVAL GRANTED FOR COMPLIANCE WITH AS/NZS 4013.

CAUTION: MIXING OF APPLIANCE OR FLUE SYSTEM COMPONENTS FROM DIFFERENT SOURCES OR MODIFYING THE DIMENSIONAL SPECIFICATION OF COMPONENTS MAY RESULT IN HAZARDOUS CONDITIONS. WHERE SUCH ACTION IS CONSIDERED, THE MANUFACTURER SHOULD BE CONSULTED IN THE FIRST INSTANCE.

CAUTIONS: CRACKED AND BROKEN COMPONENTS, e.g. GLASS PANELS OR CERAMIC TILES, MAY RENDER THE INSTALLATION UNSAFE.

WARNING: ANY MODIFICATION OF THE APPLIANCE THAT HAS NOT BEEN APPROVED IN WRITING BY THE TESTING AUTHORITY IS CONSIDERED AS BREACHING AS/NZS 4013.

WARNING: DO NOT USE FLAMMABLE LIQUIDS OR AEROSOLS TO START OR REKINDLE THE FIRE.

WARNING: DO NOT USE FLAMMABLE LIQUIDS OR AEROSOLS IN THE VICINITY OF THIS APPLIANCE WHEN ITS OPERATING.

WARNING: DO NOT STORE FUEL WITHIN HEATER INSTALLATION CLEARANCES.

WARNING: FOR OPTIMUM PERFORMANCE FUEL MUST BE LOADED SO THE LOGS LAY "FRONT TO REAR" IN PREFERENCE TO LAYING ACROSS THE WIDTH OF THE FIREBOX. SPACES SHOULD BE LEFT BETWEEN THE LOGS TO ENABLE OXYGEN TO GET TO AS MUCH OF THE SURFACE OF THE FUEL AS POSSIBLE.

CAUTION: THIS APPLIANCE SHOULD BE MAINTAINED AND OPERATED AT ALL TIMES IN ACCORDANCE WITH THESE INSTRUCTIONS.

CAUTION: THE USE OF SOME TYPES OF PRESERVATIVE-TREATED WOOD AS A FUEL CAN BE HAZARDOUS.



Please contact your Heatilator dealer with any questions or concerns.
For the number of your nearest Heatilator dealer
log onto www.heatilatorecochoice.com

CAUTION



DO NOT DISCARD THIS MANUAL

- Important operating and maintenance instructions included.
- Read, understand and follow these instructions for safe installation and operation.
- Leave this manual with party responsible for use and operation.



We recommend that you record the following pertinent information for your heating appliance.

Date purchased/installed: _____

Serial Number: _____ Location on appliance: _____

Dealership purchased from: _____ Dealer phone: _____

Notes: _____

