

**INSTRUCTIONS FOR  
INSTALLATION  
AND  
OPERATION  
MODEL 24  
WOODSMAN**

**WOOD  
BURNING  
HEATER**



6.045-346

Manufactured by  
**The ATLANTA STOVE WORKS, INC.**  
P. O. Box 5254, Atlanta, Georgia 30307  
*"Over 85 Years of Knowing How"*

# SOME FACTS ABOUT YOUR HEATER

The WOODSMAN not only has the beauty and patina of a classic antique, but is a modern, well-engineered heating unit. Modern foundry technology plus years of stove building experience combine to make the WOODSMAN an updated version of an old world favorite.

The WOODSMAN is characterized by simple tailored lines, enriched with a relief sculpture on each side panel to add just the right touch in any room. The artistic moldings portray a peaceful mountain scene that will make the WOODSMAN a sure conversation piece.

In the manufacturing business for many decades, the Atlanta Stove Works, Inc. has utilized its over 80 years of experience in the production of the WOODSMAN. Crafted of quality cast iron, its multiple surface tongue and groove joints are designed to make it much more airtight than conventional cast iron wood heaters have ever been.

The high volume interior accommodates 26" logs. The spacious feed door utilizes three draft openings, precisely placed for efficient operation.

The unique horizontal baffle can be opened or closed at the side to suit your own individual heating

requirements. This is done by means of an outside control handle for your convenience.

The three adjustable TRI-AIR draft controls, in conjunction with this adjustable blade in the horizontal baffle, can induce quick starts for your fire or be used to throttle down for slow burning and maximum fire retention.

The combination of tight construction, TRI-AIR draft controls in a large feed door, large collar diameter allowing creosote return, outside control of interior baffle opening, modern foundry technology and years of stove building experience make your WOODSMAN a cleaner, more economical, and better way to heat your home.

The WOODSMAN flue opening will accept stove pipe internally so that any creosote and tars can run down inside the flue pipe and be returned to the combustion chamber for burning. This flue arrangement has been a proven feature on wood heaters we have made over many years.

Now, at last you can be energy self-sufficient with a modern wood burning stove. It is not only a money saver, but it will enhance your room decor. It combines utility and tradition, the convenient and functional with the proven.

# HERE'S HOW YOUR HEATER WORKS

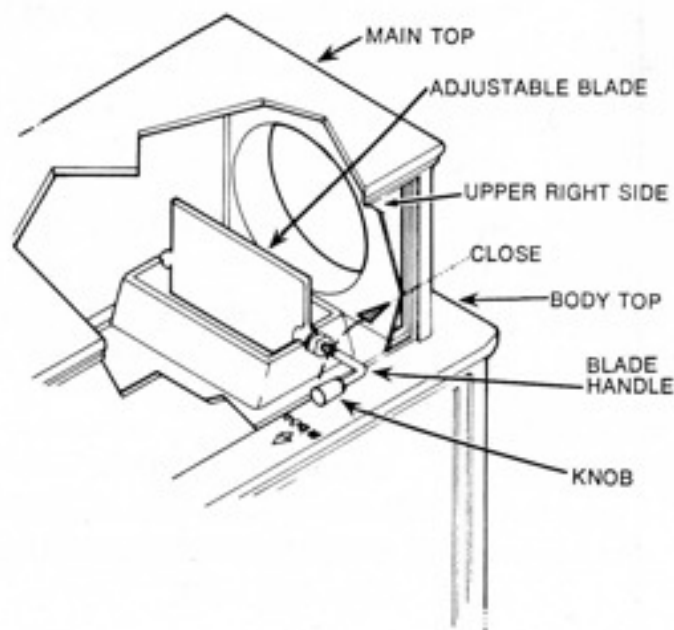
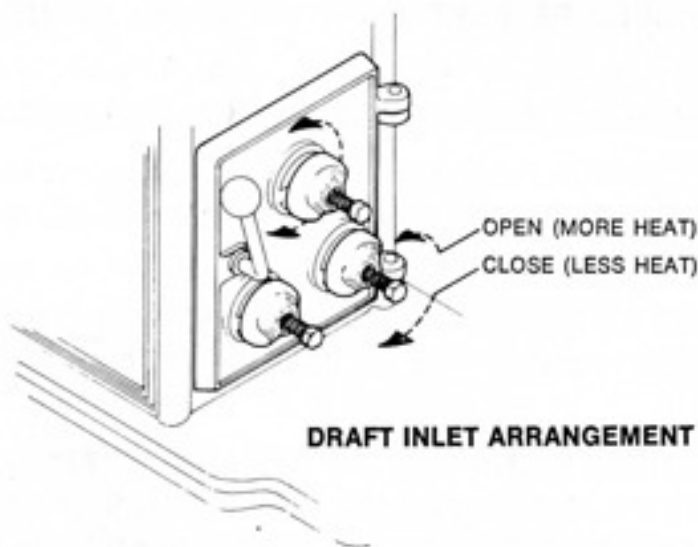
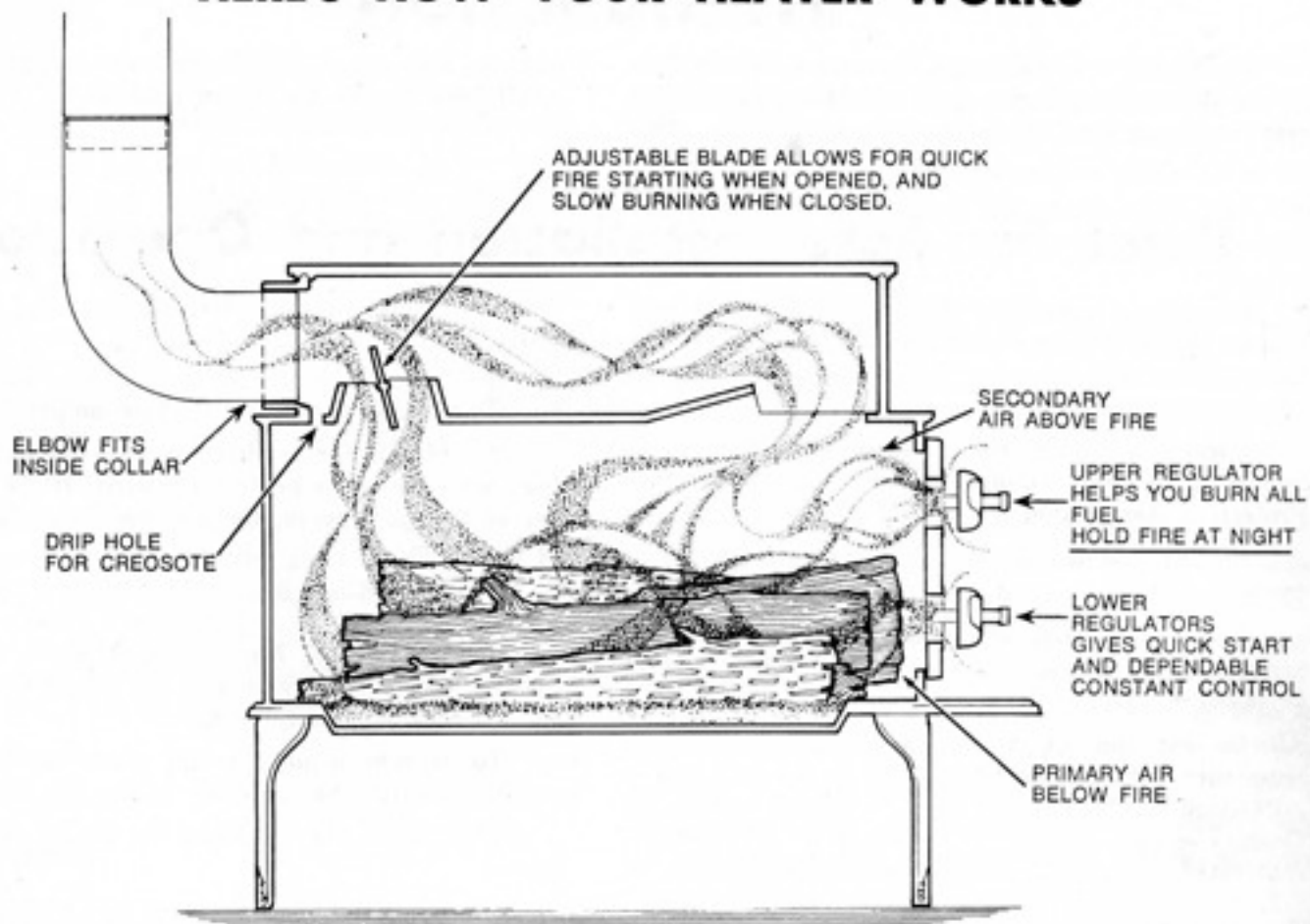

# INTRODUCTION

Please take a few minutes to read our instructions before you install and use your new Heater. This will help you obtain the full benefits from your heater. This

will also help you avoid any needless service costs that result from causes we cannot control.

## Rules For Safe Installation and Operation

Read these rules and the instructions carefully. Failure to follow them could cause a malfunction of the heater. This could result in death, serious bodily injury, and/or property damage.

Check your local codes. The installation must comply with their rulings. Refer to National Fire Protection Association codes 89M and 211.

Do not install this heater in a mobile home or trailer.

This heater must be connected to a chimney and vented to the outside. Never vent to another room or inside a building.

Do not connect a wood burning heater to an aluminum Type B gas vent. This is not safe and is prohibited by the National Fire Protection Association Code. Use only a Class "A" masonry or All-Fuel prefabricated chimney. Prefabricated chimneys must be

listed by Underwriters Laboratories (UL) Inc. The inside diameter must be at least 6 inches.

If heater is placed on combustible floor, use a non-combustible base such as brick or patio blocks.

Provide air for combustion from the outside into the room where the heater is located. If the intake is not in the same room, the air must have free access to the room.

**PARTS MUST BE "SEASONED" TO AVOID CRACKING. BUILD ONLY SMALL FIRES DURING YOUR EARLY USE.** Never build extremely large fires in your heater. If any part of the heater becomes red hot, damage will likely result.

To prevent injury do not allow anyone who is unfamiliar with the operation to use the heater.

**CAUTION:** Do not touch the heater until it has cooled.

### NOTE

### NOTE

### NOTE

1. DUE TO HIGH TEMPERATURES, WHEN IN OPERATION, THE HEATER SHOULD BE LOCATED OUT OF TRAFFIC AND AWAY FROM FURNITURE AND DRAPERIES.
2. CHILDREN AND ADULTS SHOULD BE ALERTED TO THE HAZARD OF HIGH SURFACE TEMPERATURES AND SHOULD BE KEPT AWAY TO AVOID BURNS OR CLOTHING IGNITION.
3. YOUNG CHILDREN SHOULD BE CAREFULLY SUPERVISED WHEN THEY ARE IN THE SAME ROOM WITH THE HEATER.
4. DO NOT PLACE CLOTHING OR OTHER FLAMMABLE MATERIAL ON OR NEAR THE HEATER.
5. INSTALLATION AND SERVICE SHOULD BE DONE BY A QUALIFIED PERSON. THE HEATER SHOULD BE INSPECTED BEFORE USE AND AT LEAST ANNUALLY BY A QUALIFIED PERSON.
6. IT IS IMPERATIVE THAT COMBUSTIBLE MATERIALS BE KEPT AWAY FROM HEATER TO AVOID THE POSSIBILITY OF IGNITION OF SUCH MATERIALS. THIS INCLUDES COMBUSTIBLE WALLS, CEILINGS, FURNITURE, RUGS, DRAPERIES, FUEL, AND THE LIKE.

# READ THIS ENTIRE BOOK BEFORE MAKING INSTALLATION

## GENERAL

This is a tight, cast iron wood burning heater with manually controlled air for combustion. It has been manufactured from high quality materials and with superior workmanship. The design of this heater has been tested to assure the utmost in product quality, efficiency and safety.

In order for this heater to give satisfactory and reliable service, you should follow all the instructions on installation, operation and maintenance contained in this book.

Keep this book in a safe place for ready reference. It will serve as a guide in the proper operation of the unit. If repair parts are needed, they may be ordered from the factory. It is necessary to give the model number of the heater, item number, part number, part name and number of parts required.

**NOTE:** Comply with all local and national codes regarding installation of this heater and its venting system.

## INSTALLATION OF HEATER

The heater should be located away from doors and hallways and out of the line of traffic as much as possible. When installed on a floor of combustible material, such as wood, tile, carpet, etc., the heater must

The following important facts pertain to flues and chimneys:

1. Only an approved masonry or U.L. listed all fuel metal chimney should be used.
2. The chimney top should be 2 feet higher than any part of the house or roof within 10 feet measured horizontally.
3. A straight up chimney is best.
4. The inside of a chimney should be smooth and must not have any leaks.
5. The stovepipe should project at least one inch past the inside of the chimney wall. The smoke flue of the chimney must not be used for ventilating purposes.

be placed on a fireproof base such as metal, or masonry. The heater should be located as far away from a wall or partition as necessary to prevent damage to the wall or partition. Always maintain a minimum of 36" from the back or sides of the heater cabinet to combustible wall or material. See Installation Examples.

## INSTALLATION OF STOVEPIPE

In connecting the stovepipe from the heater to the chimney, start with either straight pipe or a one-piece elbow with the crimped end always toward the heater. If the heater is venting into a fireplace opening, the front of the fireplace should be made airtight except for the opening for the stovepipe. The pipe should slope upward slightly from the heater to the chimney. If the fireplace cover is combustible, an approved fireproof thimble must always be used and the heater must not be installed closer than 36". In making any type of stovepipe connection to a chimney, use the smallest number of elbows possible and slope the horizontal pipe upward toward the chimney. Use sheet metal screws at each pipe joint and where the pipe attaches to the heater. A small quantity of stove putty or cement should be used to seal each joint. After the stovepipe is installed, wipe excess putty or cement and finger marks from the pipe and heater cabinet. Do not use adjustable type elbows, as creosote will leak through.

6. The smallest opening in the flue pipe or chimney must not be smaller than the connecting collar on the back of the heater.
7. A chimney has less draft when the fire is first started as the air in the flue is damp and the temperature lower than when the fire is burning well. A round flue draws best since smoke and hot air will rise in a solid spiral column.
8. Chimneys built on the outside of a house must be at least eight inches thick to prevent chilling of the flue space within.
9. An approved chimney cap should be installed to prevent the entrance of water and to guard against downdraft.

**SEE INSTALLATION EXAMPLES**

## A NOTE ABOUT CHIMNEY FIRES

When wood is burned slowly, such as under low fire conditions, creosote or tars are formed in the combustion products. These tars are deposited in time on the inside of the flue and chimney pipe. With enough build-up, these tars can ignite and cause a fire inside the chimney until the burnout is complete. A Class "A" U.L. listed all fuel chimney is sufficient to contain the fire, but distortion can result. If such a burnout should occur, your chimney should be inspected immediately and any deformed, warped or otherwise distorted parts replaced before further use.



## OPERATING INSTRUCTIONS — GENERAL

After the heater is installed properly, to an approved chimney, it is ready for operation. The first few fires should be small in order to properly temper the cast iron parts. The burning rate of the wood used in the heater is controlled by the amount of air (oxygen) admitted to the fire. The three manual draft regulators on the fire door are arranged to give you complete TRI-AIR comfort control. The two lower regulators give you fast start up. The upper regulator supplies secondary air for more complete burning of the wood. A proper adjustment of the three, controls the fire to your needs.

**CAUTION:** It is not intended that the heater be operated with fire door open. Overfiring may result in damage to the heater and sparks popping out into the room could occur. It is not possible to control the fire with the fire door open.

**NOTE:** Ashes should be disposed of outside the house and away from any type of combustible material. If this is not possible, they should be stored in a covered fireproof container until they are cool.

## BUILDING THE FIRST FIRE — PUTTING HEATER INTO OPERATION

1. Use wood only. (NEVER USE FLAMMABLE LIQUIDS SUCH AS GASOLINE, KEROSENE, ETC., AS EXPLOSION MAY RESULT).
2. Open the bottom draft regulators by turning 10 turns to the left. This will leave a  $\frac{3}{4}$ " space between regulator and door. Close upper regulator then turn the knob on adjustable blade in horizontal baffle to open position. This will give a direct draft to flue for quick start up. Knob is located at back end of upper right side.
3. Lay a small amount of wadded-up newspaper on the floor of heater and small dry pieces of wood may be placed on top of the paper.
4. Light the fire and soon as it is burning, close the fire door.
5. After the fire is burning well (a few minutes depending on how dry the wood is), open fire door and fill fire box about one-half full of wood. Close fire door securely.
6. After the heater gets hot, you may set the draft regulators for the desired heat. The proper setting can only be obtained by trial since conditions of fuel, space being heated, individual preference, etc., vary. After some experience with the heater you will learn the best setting for your needs. Generally the best setting is when the space between the draft regulator and draft opening is about  $\frac{1}{8}$  inch—about the length of the following dark line . For more heat turn the regulator to the left . For less heat turn to right .
7. Close the adjustable blade in horizontal baffle after fire is burning well, keep closed when on low fire and when holding fire at night.

**CAUTION:** The cabinet, cast iron door and other parts of the heater and flue pipe get very hot when the heater is burning. Therefore, when tending the heater, to avoid burns, gloves should be used and direct contact with hot parts avoided.

## PREPARING THE HEATER TO HOLD FIRE

1. To hold fire overnight, fill heater about one-half to two-thirds full of good wood (logs preferred) and close two lower draft regulators. Adjust upper draft regulator to where the space between the regulator is  $\frac{1}{8}$ ". A good method of adjusting is to close the draft regulator completely then open to left  $1\frac{1}{4}$  turns. This will give the  $\frac{1}{8}$ " opening. See "Here's How Your Heater Works" page 3.
2. If more heat is desired, open bottom draft regulator  $1\frac{1}{4}$  turns. This will permit fuel to burn somewhat faster and generate more heat. However, you may find that the fire will not hold as long as desired. After some experience, you will learn just how to operate your heater for best results.
3. In the morning, after the heater has been holding the fire overnight and more heat is needed, you should close top regulator, open fire door and adjustable blade in baffle, stir up coals of fire, pull coals to front of heater, add desired amount of wood, and open both bottom regulators until fire is burning well and then set to desired position. Close adjustable blade. NOTE: Be sure fire door is securely closed. With proper draft adjustment and wood loading fire can be held for 12 to 17 hours.

## SOME FACTS ON FUEL

1. This heater is designed to burn wood only.

## DO NOT BURN COAL OR COKE OR OTHER FUELS.

2. Dry wood will give a better and easier to control fire than wet or green wood. Hardwood will give

better results than pine. Pine and green wood will produce more distillates (such as creosote) than other woods.

Logs will hold fire much longer than slab-wood or blocks. Frozen wood with ice or snow on it may crack the castings or smother the fire and therefore should not be used. Wood that has been saturated with salt water will cause deep corrosion in metal parts and should not be used.

## MAINTENANCE INSTRUCTIONS

1. Maintain area around heater. Keep it free of combustible materials, flammable liquids, dust, lint, etc. Do not use or store gasoline or cleaning fluids in same area where heater is located.
2. Do not allow excessive ashes or unburned materials to build up in fire box.
3. Do not allow an excessive build-up of soot or creosote in fire box or flue.
4. At the beginning of each heating season, have the heater, flue-pipe and chimney inspected by a qualified service person to be sure it is in good working condition. Make any repairs that may be needed without delay.

## REPAIR PARTS

In ordering parts for this heater, refer to repair parts illustration. Give model number of heater, item number, part number of part, part name of part and quantity of parts needed.

# INSTALLATION EXAMPLES

**NOTE:** These clearances are min. clearances for heater. Always locate heater so min. clearance from flue pipe to combustible wall will be maintained (such as with a vertical flue)

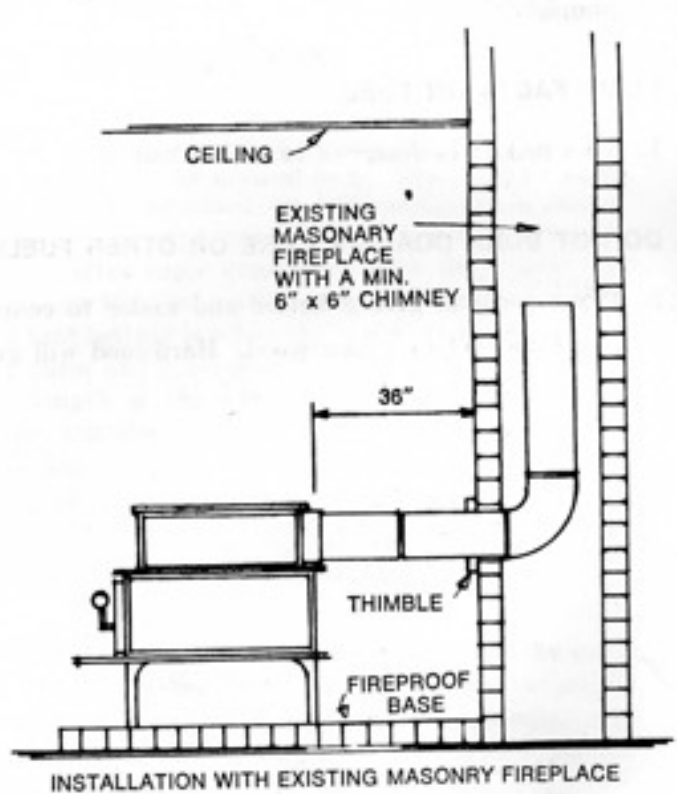
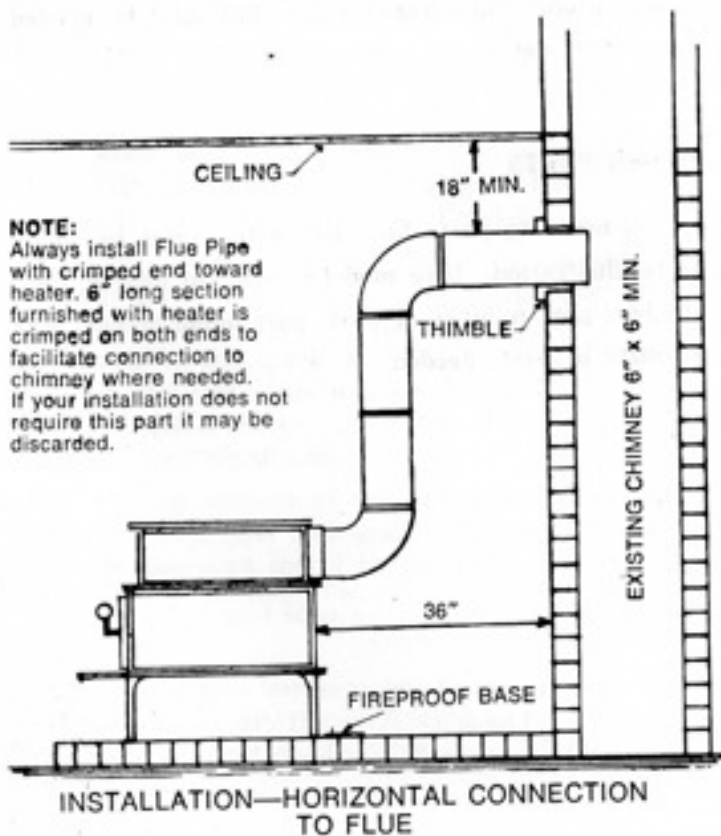
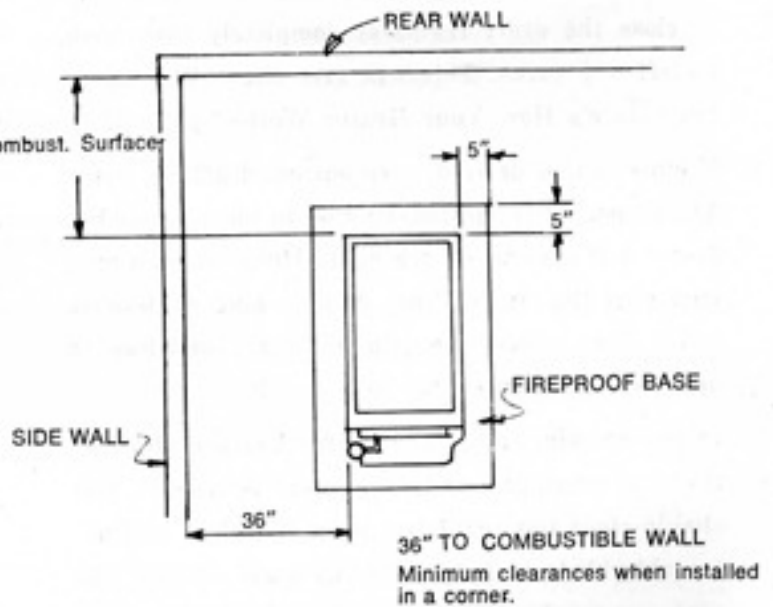
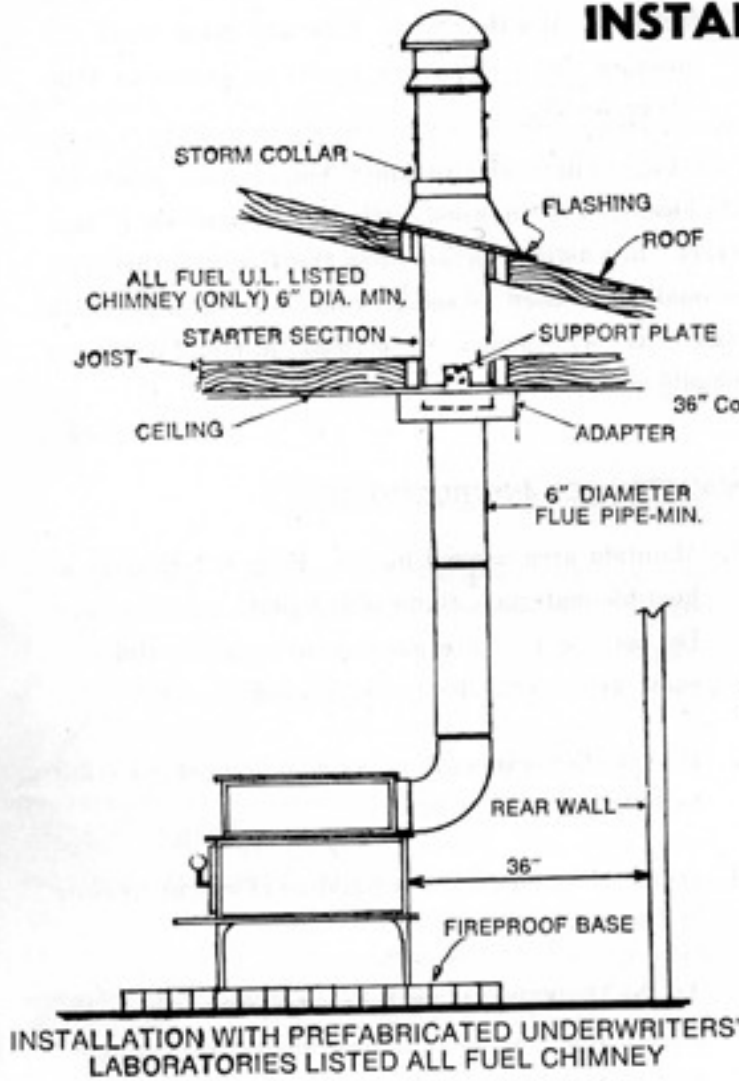



# GLOSSARY

## AIRTIGHT STOVES

A stove which is sufficiently airtight that its performance would be indistinguishable from a stove of the same overall design which was literally airtight. In a literally airtight stove, all the air which enters it goes in through the air inlet(s). Generally, non-airtight stoves are less energy efficient and their level of heat output is less controllable than airtight stoves.

## BAFFLE PLATE

A partition inside a stove to control the direction of flow of combustion air, flames, or flue gases.

## Btu or BRITISH THERMAL UNIT

A unit for measuring energy, equal to the amount of energy necessary to increase the temperature of 1 pound of water by 1 degree Fahrenheit.

## CHIMNEY CONNECTOR

That portion of a stove's venting system between the stove and its chimney. Chimney connectors are usually made of stovepipe.

## CIRCULATING STOVES

A stove with an outer jacket, beyond the main structure, with openings at the bottom and top so that air can circulate. Circulating stoves transfer more than half of their heat output as heated air. (See Radiant Stove.)

## COMBUSTION PRODUCTS (OR PRODUCTS OF COMBUSTION)

The products of the chemical reactions which constitute combustion, typically consisting of carbon dioxide, water vapor and small amounts of some incompletely burned organic compounds.

## CORD

A common measure of firewood and pulpwood, equal to the amount of wood in a carefully stacked (parallel) pile of wood which is 4 feet high, 8 feet wide and 4 feet deep. The amount of solid wood in this 128 cubic foot pile is usually estimated to be between 80 and 90 cubic feet.

## CREOSOTE

Chimney deposits originating as condensed organic vapors or condensed tar fog. Creosote is often initially liquid, but may dry and/or pyrolyze to a solid or flaky form.

## DAMPER

A valve (usually a movable or rotatable plate) for controlling the flow of gases and/or the draft in stoves and in stovepipe.

## DRAFT

The difference in air pressure inside and outside a chimney or stove. Draft also is used to mean air flow.

## EFFICIENCY OR ENERGY EFFICIENCY

As applied to a wood stove, the fraction (or percentage) of the chemical energy in the wood which is

converted to useful heat by the stove, including the heat from an average amount of exposed stovepipe (about 6 feet).

## FIRE BRICK

Brick capable of withstanding high temperatures, such as in furnaces and kilns. Firebrick is often used to mean only "hard" or "dense" fire brick as distinguished from "soft" or "insulating" fire brick.

## FLUE COLLAR

The part of a stove to which the chimney connector or chimney attaches.

## FLUE GASES

The gaseous combustion products from fuel-burning appliances, plus whatever air is mixed with them i.e., the gases in an operating flue.

## GREEN WOOD

Undried freshly cut wood from a live tree.

## HEART WOOD

The wood in the center of a tree extending out to the sapwood. The heart wood no longer participates in the tree's life processes. It is usually darker in color and more resistant to decay. Young trees have no heart wood.

## IGNITION TEMPERATURE

The minimum temperature of a flammable mixture of gases at which it can spontaneously ignite.

## INFRARED RADIATION

The invisible (and harmless) radiation emitted by any hot object, which is converted into heat when it is absorbed.

## LATENT HEAT

The potential energy in water vapor which is converted into (sensible) heat when the vapor condenses. A pound of water vapor at room temperature has about 1050 Btu of latent heat.

## LINER OR STOVE LINER

A layer of metal or brick placed immediately adjacent to a side or bottom of a stove, intended either to protect the main stove structure from getting too hot, or to insulate the combustion chamber, making it hotter and thus promoting more complete combustion. Liners are usually designed for easy replacement.

## OVENDRY WOOD

Wood which has been dried to constant weight at about 215 degrees Fahrenheit and low humidity. Oven-dry wood is defined to have zero moisture content.

## PRIMARY COMBUSTION

The burning of solid wood and some of the combustible gases, which takes place in that portion of the stove where the wood is. The distinction between primary and secondary combustion is somewhat artificial and hence not always clear.

### **PYROLIGNEOUS ACID**

The acidic brown aqueous liquid obtained by condensing the gaseous products of pyrolysis of wood. Pyroligneous acid is the same as creosote in its wettest form.

### **PYROLYSIS**

The chemical destruction of wood by the action of heat alone, in the absence of oxygen and hence without burning. The products of pyrolysis are gases, tar, fog, and charcoal.

### **RADIANT STOVE**

A stove without the outer jacket that circulating stoves have. Radiant stoves transfer more than half their energy output in the form of radiation.

### **SAPWOOD**

The wood extending from the heart wood out to the bark in a tree. Sapwood participates in transporting sap up and down a tree. Sapwood usually is lighter in color than heartwood and is usually more susceptible to decay.

### **SEASONED WOOD**

Wood which has lost a significant amount of its original (green) moisture. The term has no more specific (and universally accepted) meaning.

### **SECONDARY COMBUSTION**

The burning of the combustible gases and smoke which are not burned in primary combustion.

### **SMOKEPIPE DAMPER**

A damper installed in a smokepipe to regulate flow and draft.

### **STACK EFFECT**

The effects resulting from the warm air in buildings on a cold day being relatively buoyant, just as are the flue gases in a chimney or stack. Effects include pressure differences between inside and outside the building, airflow into the building in the lower stories and airflow out of the building in the upper portions.

### **STOVEPIPE**

Single-walled metal pipe and fittings intended primarily to be used for chimney connectors but also sometimes used for chimneys.

### **THIMBLE**

A device to be installed in combustible walls, through which stovepipe passes, intended to help protect the walls from igniting due to stovepipe heat. A thimble by itself is not usually adequate. The simplest thimbles are simply metal or fire-clay sleeves or cylinders.

# REPAIR PARTS ILLUSTRATION

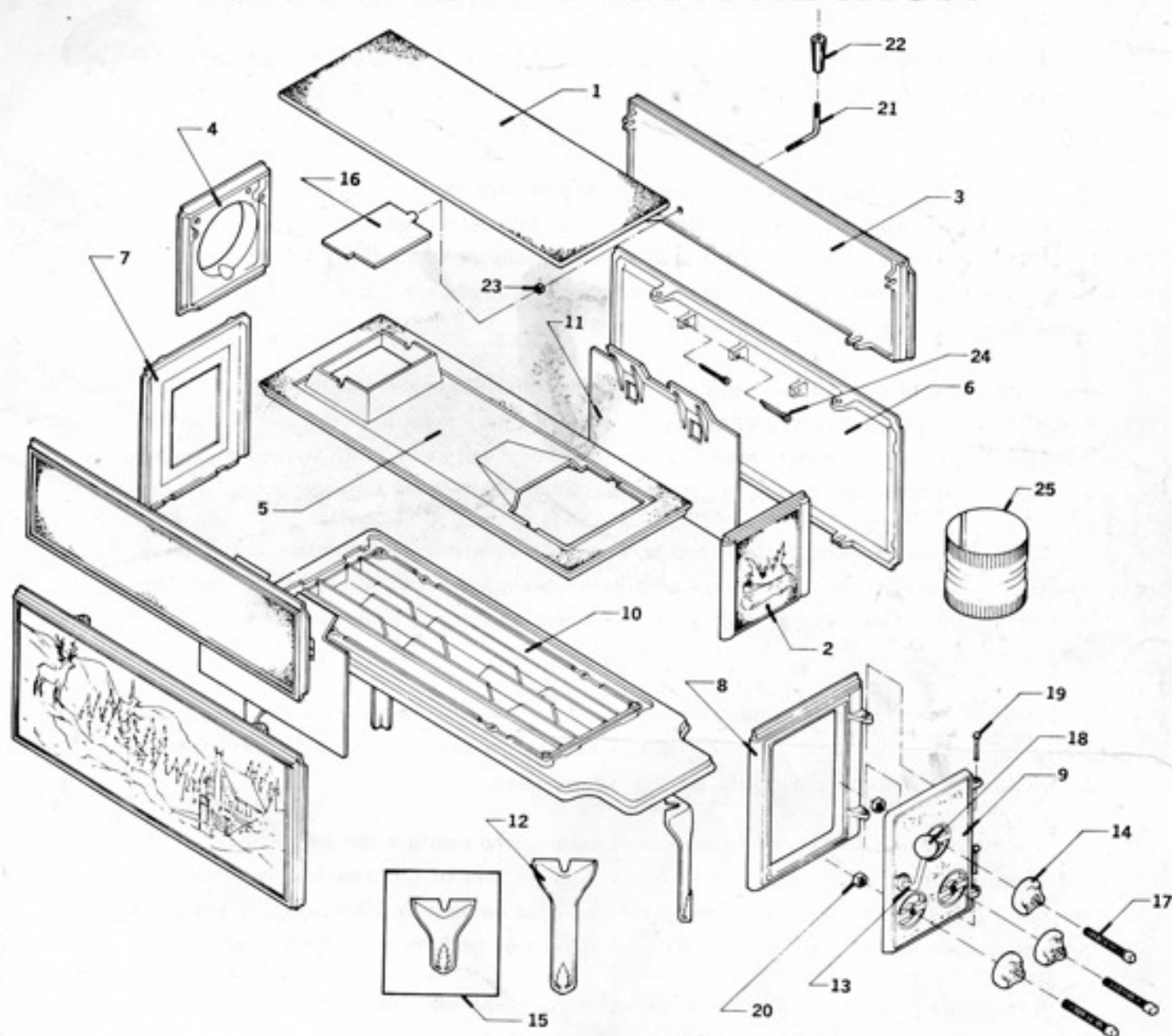

## REPAIR PARTS LIST 24 WOODSMAN

KEY NO.	QUAN.	PART NAME	PART NO.
1	1	TOP	3800
2	1	UPPER FRONT PANEL	3801
3	2	UPPER SIDE PANEL	3802
4	1	FLUE PLATE	3803
5	1	BODY TOP	3804
6	2	SIDE	3805
7	1	BACK	3806
8	1	FRONT	3807
9	1	DOOR	3820
10	1	BOTTOM	3810
11	2	SIDE LINER	3811
12	4	LEGS, LONG	3813

KEY NO.	QUAN.	PART NAME	PART NO.
13	1	DOOR HANDLE	6.024-158
14	1	DRAFT REGISTER	3815
15	4	LEGS, SHORT (OPTIONAL)	3821
16	1	BLADE, ADJUSTABLE (DAMPER)	3817
17	3	HEX HEAD BOLT	6.011-805
18	1	DOOR KNOB	6.022-212
19	2	HINGE PIN	6.013-111
20	3	HEX NUT ½-13	6.011-023
21	1	BLADE CONTROL ROD	6.024-153
22	1	BLADE CONTROL KNOB	6.022-214
23	1	HEX NUT 10-24	6.011-021CD
24	4	COTTER PIN	6.014-262
25	1	STOVE PIPE—¼ JOINT 6"	6.140-130

# THANK YOU FOR BUYING THIS STOVE.

We are very pleased that you have chosen to purchase one of our products. We are proud that our company's manufacturing operations date back over 75 years and began with the purpose of producing coal and wood burning stoves and cast iron holloware.

For several decades the manufacture of coal and wood burning appliances for cooking and heating was our primary business. Our sheet metal fabrication and particularly our foundry have grown over the years and progressed technologically to where today we can conservatively claim to be one of the largest and most experienced producers of this line of merchandise in the country and probably in the world.

Please read this instruction booklet thoroughly. It should enable you to safely and effectively use and enjoy this stove you have purchased. We have made it from materials that we believe will give the optimum combination of durability and value. But, it requires proper installation and operation for you to get the maximum in efficiency and safety.

Any solid fueled stove, burning coal or wood, will eventually need repairs, if it is used. Availability of repair parts has always been both a policy and a point of pride in our company. This repair part availability protects your investment and is not generally obtainable from foreign made products.

Many foreign foundries change from product to product and have no product liability obligation to the American consumer. Such manufacturers are not in the business for the long pull as are domestic manufacturers like our company.

We owe our existence to the American consumer, who provides the job security for our American workers. What future our company has we owe to the American consumer and therefore feel obligated, as a matter of pride and good common business sense, to provide a product you can be proud of and one that will effectively perform the job intended.

Thank you for your confidence in us and in our customer from whom you purchased this stove. We hope and believe you will be pleased with it.