

STANDARD BOXWOOD STOVE

Model BX26E Owners Manual

(Save These Instructions)



READ ALL INSTRUCTIONS CAREFULLY BEFORE INSTALLING OR OPERATING THIS STOVE. FAILURE TO FOLLOW INSTRUCTIONS MAY RESULT IN PROPERTY DAMAGE, BODILY INJURY, OR EVEN DEATH.

REFER TO MARKINGS ON STOVE LABELS FOR ADDITIONAL INFORMATION.

SAFETY NOTICE: IF THIS STOVE IS NOT PROPERLY INSTALLED, A HOUSE/BUILDING FIRE MAY RESULT. FOR YOUR SAFETY, CONTACT LOCAL OR MUNICIPAL BUILDING OR FIRE OFFICIALS ABOUT PERMITS, RESTRICTIONS, AND INSTALLATION REQUIREMENTS FOR YOUR AREA.

This stove is not a UL Listed stove.

NOTE: IT IS RECOMMENDED INSTALLATION BE COMPLETED BY A QUALIFIED HEATING EQUIPMENT INSTALLER!

DO NOT INSTALL IN A MOBILE HOME.

VOGELZANG

International CORPORATION



Vogelzang International Corporation
400 West 17th Street
Holland, Michigan 49423
www.vogelzang.com
Phone: 1-616-396-1911
Fax: 1-616-396-1971

SAFETY INSTRUCTIONS

Read All Instructions carefully.

1. The installation of this stove must comply with your local building code rulings. Please observe the clearances to combustibles (see reference figures 7–9). Do not place fuel, furniture or any other objects within the clearance area.
2. Verify that the stove is properly installed before firing the stove for the first time. After reading these instructions, if you have any doubt about your ability to complete your installation properly, you must obtain the services of a professional licensed installer familiar with all aspects of safe and correct installation. **DO NOT** use temporary or makeshift compromises during installation. There must be **NO DEVIATION OR ALTERATION OF ANY KIND** from the very specific instructions spelled out in this instruction manual as it pertains to the installation of this woodstove. **NO EXCEPTIONS!**
3. **DO NOT** store wood, kindling, flammable liquids or other combustible materials in the vicinity of the appliance. Refer to certification label on back of unit and reference figures 7–9 in this manual.
4. **DO NOT INSTALL THIS STOVE IN A MOBILE HOME, MANUFACTURED HOME, TRAILER OR TENT NO EXCEPTIONS! (HUD Federal Standard: 24 CFR Ch.XX).**
5. **DO NOT ELEVATE THIS STOVE BY ANY MEANS.** (i.e. bricks under legs, cement blocks) Stove legs must set directly upon the solid-surface non-combustible floor as specified in this stove instruction manual.
6. **DO NOT MODIFY THIS STOVE IN ANY WAY!** Stove must be installed with legs attached as shown in the instructions. Assemble only with original parts as supplied and shown in this manual. **DO NOT OPERATE A STOVE THAT IS MISSING ANY PARTS!** If any parts are missing or defective, please notify the dealer or manufacturer immediately. Replace missing, broken or worn parts with factory original or equivalent parts only.
7. Do not tamper with combustion air control beyond normal adjustment capacities.
8. Always connect this stove to a chimney and vent to the outside. Never vent to another room or inside a building. **DO NOT CONNECT THIS UNIT TO A CHIMNEY FLUE SERVING ANOTHER APPLIANCE.**
9. **DO NOT CONNECT A WOOD BURNING STOVE TO AN ALUMINUM TYPE B GAS VENT.** This is not safe. Use approved masonry or an Underwriters Laboratories Listed UL 103HT / ULC-S629 Residential Type and Building Heating Appliance Chimney. Use a 6"/152mm diameter chimney, that is high enough to give a good draft. (See specifics in Chimney Connections instructions).
10. Be sure that your chimney is safely constructed and in good repair. Have the chimney inspected by the fire department or a qualified inspector. Your insurance company should be able to recommend a qualified inspector. Chimney connector pipe must be in good condition. Replace if necessary before using stove.
11. Creosote or soot may build up in the chimney connector and chimney and cause a house/building fire. Inspect the chimney connector and chimney twice monthly during the heating season and clean if necessary. (see Service Hints).
12. In the event of a chimney fire, turn the air control and flue damper to closed positions, leave the building and **CALL THE FIRE DEPARTMENT IMMEDIATELY!** Have a clearly understood plan on how to handle a chimney fire by contacting your local fire authority for information on proper procedures in the event of a chimney fire. After the fire is out, the chimney must be cleaned and inspected for any stress or cracks before starting another fire. Check the condition of any combustibles surrounding the chimney.
13. Ashes should not be allowed to accumulate above the top of the hearth plate.
14. **DISPOSAL OF ASHES**
Ashes should be placed in a steel container with a tight fitting lid and moved outdoors immediately. The closed container of ashes should be placed on a noncombustible floor or on the ground, well away from all combustible materials, pending final disposal. If the ashes are disposed of by burial in soil or otherwise locally dispersed, they should be retained in the closed container until all cinders have completely cooled. Other waste shall not be placed in this container.
15. To prevent injury, do not allow anyone to use this stove who is unfamiliar with the correct operation of the stove.
16. Do not operate stove while under the influence of drugs or alcohol.
17. The special paints used on your stove may give off some smoke and an odor while they are curing during the first 12 to 15 fires. Additional smoke and odor may be emitted from the light oils used in construction of the fire box. This should disappear

SAFETY INSTRUCTIONS *continued...*

- after a short period of time and not occur again. Persons with lung conditions or owners of susceptible domestic pets (such as birds) should take prudent precautions. Open windows and doors as needed to clear smoke and/or odor. Paint discoloration will occur if the stove is over fired.
18. This stove has a painted surface which is durable but it will not stand rough handling or abuse. When installing your stove, use care in handling.
 19. Clean exterior with soap and warm water when stove is not hot. Do not use any acids or scouring soap, as these solvents wear and dull the finish.
 20. **CLEAN STOVE FREQUENTLY** as soot, creosote and ash may accumulate.
 21. **ALERT ALL PERSONS TO THE HAZARDS OF HIGH SURFACE TEMPERATURES** while stove is in operation – especially young children. Keep away from a hot stove to avoid burns or clothing ignition.
 22. **NEVER LEAVE SMALL CHILDREN UNSUPERVISED WHEN THEY ARE IN THE SAME ROOM AS THE STOVE.** If small children will be in the same room as the stove during operation, provide a sturdy barrier to keep them at a safe distance from the stove.
 23. Keep stove area clear and free from all combustible materials, gasoline, engine oil, naphtha and other flammable vapors and liquids.
 24. **WHILE TENDING THE FIRE ALWAYS WEAR PROTECTIVE CLOTHING**, fire retardant hearth gloves and eye protection, to prevent burns.
 25. Never operate this stove with the door open except when re-fueling. Such actions can result in very dangerous operating conditions.
 26. **DO NOT OVER FIRE THE STOVE.** Over firing will occur if combustion air is uncontrolled as when feed door is left open during operation. Such actions can result in very dangerous operating conditions. While in operation, keep the feed door closed and secured at all times except while tending the fire
 27. Do not load the fuel to a height or in such manner that it would be hazardous when opening the door.
 28. **NEVER LEAVE THE STOVE UNATTENDED** when the door is open. Always close the door after ignition.
 29. **DO NOT CONNECT TO OR USE IN CONJUNCTION WITH ANY AIR DISTRIBUTION DUCT WORK UNLESS SPECIFICALLY APPROVED FOR SUCH INSTALLATIONS.**
 30. **A WOOD-BURNING STOVE MUST NEVER BE INSTALLED IN A HALLWAY OR NEAR A STAIRCASE, as it may block egress in the event of a fire.**
 31. **DO NOT INSTALL IN AN ALCOVE OR INSIDE A FIREPLACE.**
 32. Install at least one smoke detector on each floor of your home. Detectors should be located away from the heating appliance to avoid false alarms. Detectors should be located close to sleeping areas. Follow the smoke detectors manufacturer's placement and installation instructions. Maintain smoke detector per manufacturer's instructions.
 33. **CARBON MONOXIDE (CO) HAZARD.** A buildup of CO fumes is toxic and can be fatal. Carbon Monoxide is a colorless, odorless gas produced during combustion of wood, coal, oil, gas and by other fuel burning appliances. It is important to have a proper draft and adequate replacement air ventilation so fumes are drawn out the chimney. Installed as instructed this stove is designed to be as safe as possible yet it is recommended to **install a CO detector.** Follow the manufacturer's recommendations for proper installation and use. It is recommended to be placed at table-top level (not near the ceiling) to avoid false alarms. Realize that devices other than a stove (i.e. motor exhaust) can trigger CO alarms.
If alarm sounds:
 - Recognize the symptoms of CO poisoning (headaches, nausea & drowsiness).
 - Increase ventilation (open windows & doors).
 - Make sure stove doors and/or lids are closed and secured.
 - Check stove for smoking or puffing (open airflow controls).
 - Check chimney & connector pipe for leaks, blockage or down-draft conditions.
 - Check CO device for false alarm.
 33. Keep power cords, electrical appliances and/or assemblies outside of the clearance area shown in this manual for combustible materials.
 34. Consult your municipal building department or fire officials about restrictions, permits and installation requirements for your area.
 35. For further information on using your stove safely, obtain a copy of the National Fire Protection Association (NFPA) publication, "Using Coal and Wood Stoves Safely" NFPA No. HS-10-1978. The address of the NFPA is Batterymarch Park, Quincy, MA 02269.

TABLE OF CONTENTS

Safety Precautions.....	2 – 3
Tools and Materials Required for Installation.....	5
Assembly Instructions	5
Locating the Stove	6
Floor Protector, Minimum Clearances	7
Connector Pipe Installation.....	8
Chimney Connections/Draft.....	9 –11
Chimney Connection Systems & Clearances.....	12
Operating Instructions	
House Fire Hazards, Operating Precautions, Warnings	13
Wood Types/Sizes.....	13
Starting a Fire	13
Adding Fuel	14
Service Hints	
Creosote Formation, Prevention, Need for Removal	14
Stove Joints	15
Parts – Standard Boxwood	16
Floor Protector Calculations.....	17

NOTE: A PROFESSIONAL, LICENSED HEATING AND COOLING CONTRACTOR MUST BE CONSULTED IF YOU HAVE QUESTIONS REGARDING THE INSTALLATION OF THIS SOLID FUEL BURNING APPLIANCE.

ASSEMBLY INSTRUCTIONS

NOTICE: Vogelzang International Corp. grants no warranty, stated or implied, for the installation or maintenance of your wood stove and assumes no responsibility of any incidental or consequential damages.

TOOLS REQUIRED

Safety Glasses
Hearth Gloves
Pencil
6 foot Folding Rule or Tape Measure
Tin Snips
Drill: Hand or Electric
1/8" dia. Drill Bit
(sheet metal screws)

Screwdrivers
(blade and Phillips types)
5/16" Nut Driver or Ratchet with 5/16" Socket (for 1/4" Hex Nuts)
11mm Nut Driver or Ratchet with 11mm Socket (for Stove Bolts)

MATERIALS REQUIRED

(NOTE: The following items are NOT included with your stove)

Flooring Protection: 48" x 70" as specified (see page 3)
Chimney Connector Pipe: 6" black steel (24 ga. min.) straight or elbow (as required)
1/2" Sheet Metal Screws

Chimney: Existing 6" Lined Masonry Chimney or 6" I.D. manufactured chimney listed to UL 103 HT.
Furnace Cement (manufacturer recommends Rutland Code 78 or equivalent)

CAUTION: STOVE IS HEAVY. MAKE SURE YOU HAVE ADEQUATE HELP AND USE PROPER LIFTING TECHNIQUES WHENEVER MOVING STOVE.

Refer to diagram and parts lists at back of this manual.

1. Uncrate the stove and remove packing materials and protective poly bag. (Save exterior cardboard box for further assembly.)
2. Remove parts from inside of stove. Parts include: one swing top (#9), two lids (#10), one lid support (#11) one damper collar (#13), one feed door (#7), one lid lifter (#15), one slide damper (#5), four legs (#1), hardware pack (#16), and S-Hook (#17) from inside firebox.
3. Place flattened carton on floor and carefully turn stove over onto carton.

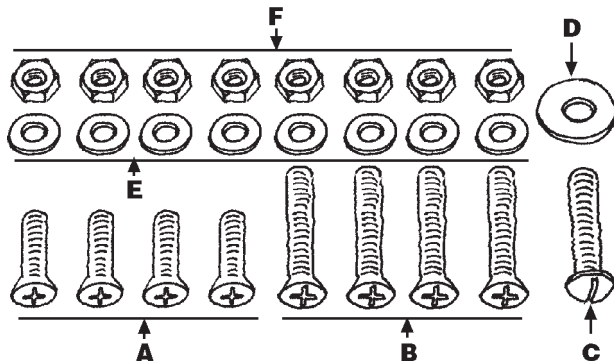

ill. A – Hardware Pack

4. Attach the rear legs to base of stove with long stove bolts (B), flat washer (E) and hex nut (F).
5. Attach hearth to bottom of stove with two short stove bolts (A), washers (E) and hex nuts (F).
6. Attach the front legs to hearth with long stove bolts (B), flat washers (E) and hex nuts (F).

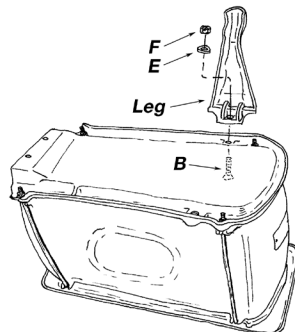

ill. B – Rear Leg Assembly

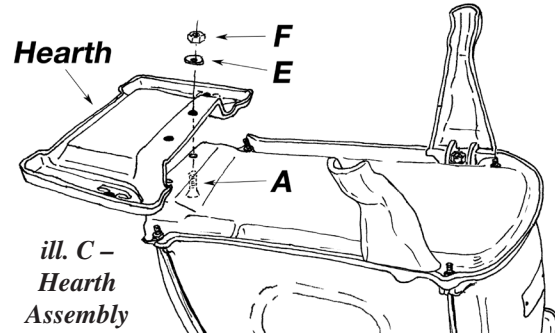

ill. C –
Hearth
Assembly

7. Carefully lift stove upright and place in desired location (see following instructions for properly locating stove).

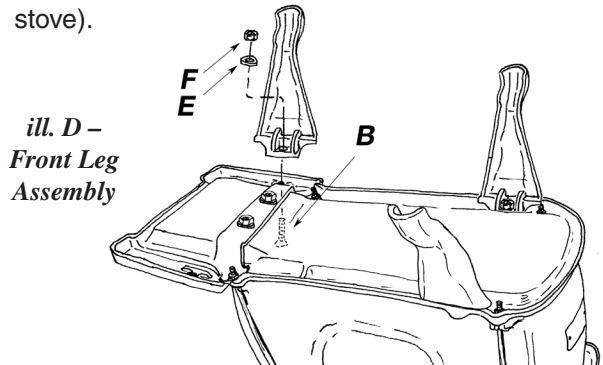

ill. D –
Front Leg
Assembly

8. Attach damper collar to rear top surface of stove using short stove bolts (A) flat washers (E) and hex nuts (F).

9. Place swing top in position on top of stove. To install, position at approximately 45 degree angle to stove (dashed lines in ill. F) until pins drop into locator holes then swing into position.

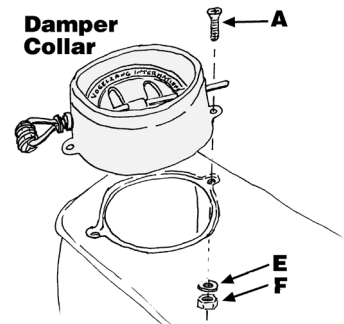

ill. E – Damper Collar

10. Place lid support and two lids in position on swing top (see ill. F).
11. Place the slide draft into position on the hearth. Hold in position with round head stove bolt (C) and large flat washer (D).

continued on next page

ASSEMBLY INSTRUCTIONS *continued...*

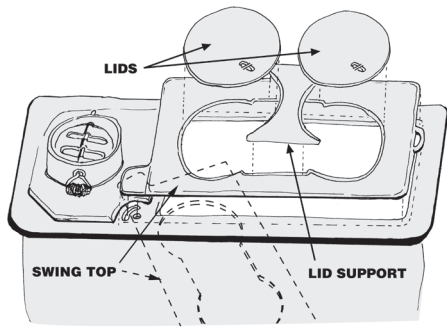

ill. F – Swing Top, Lid Support & Lids (2)

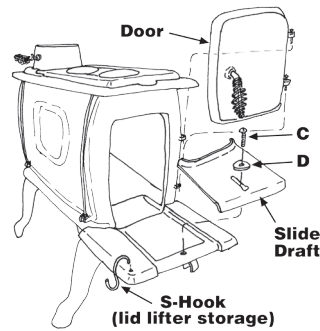

ill. G– Slide Draft, Door & S-Hook (lid lifter storage) Location

12. Lower feed door into position while aligning hinge pins.
13. Place S-Hook in hole at left front corner of hearth. Note: S-Hook is used to hang lid lifter while not in use.

LOCATING STOVE

Proper clearances must be maintained for adequate air circulation and protection from radiant heat. Adequate ventilation must be provided while operating this stove.

1. The stove must be placed on solid concrete, solid masonry, or when installed on a combustible floor, on a Type 2 floor protector listed to standard UL 1618 with a minimum R value of 3.0 and a minimum thickness of 1" or equivalent. The floor protector is required to provide heat, live ember, and ash protection and must be of a non-combustible, continuous solid surface to protect against infiltration of live embers and ash. For UL Listed floor protectors, refer to manufacturers instructions for installation directions. Manufacturers of listed floor protectors include Imperial Metal Products and Hy-C among others. To calculate R-Values for alternative methods, see page 16. Floor protector must extend at least 18" beyond the front of the hearth, to the sides, and beyond the rear of the stove. The area under a horizontal run of the chimney connector must also be protected; extending two (2) inches beyond the outer dimension of the horizontal connector. The minimum sized floor protector for this stove is 48" x 70". Consult local building codes and fire protection ordinances.

CAUTION: (FIRE HAZARD) CARPETING AND OTHER COMBUSTIBLE MATERIAL MUST NOT COVER THE FLOOR PROTECTOR. THESE MATERIALS MUST REMAIN OUTSIDE OF COMBUSTIBLE CLEARANCES, SEE FIG. 1-3.

2. The stove must have its own flue. **DO NOT CONNECT TO ANY AIR DISTRIBUTION DUCT OR SYSTEM.**
3. After observing the clearances to combustible materials (figure 1–3), locate your floor protector accordingly and carefully place the stove in your selected location. Install connector pipe, elbows, and thimble as required, utilizing either a

recently cleaned and inspected 6" masonry chimney or a 6" i.d. manufactured chimney, listed to UL 103 HT. Maximum 64 square inches.

4. Use round 6" dia., minimum 24 MSG black or 26 MSG blue steel stove pipe to connect the stove to the chimney. **DO NOT USE GALVANIZED DUCT PIPE AS A CONNECTOR.** Secure connector pipe to the flue collar with three (3) sheet metal screws. Secure pipe/elbow sections with three sheet metal screws at each joint to make the piping rigid. Screws may be no more than a maximum of 3"/76mm apart. **DO NOT** connect this stove to any air distribution or duct system.
5. Recheck clearances from the stove, connector stove pipe, and corner clearances using the illustrations (figure 1–3) and your local building codes or fire protection ordinances.

NOTE: ANY WALL CONTAINING COMBUSTIBLE MATERIAL SUCH AS WOODEN STUDS OR DRYWALL AND FACED WITH BRICK OR STONE MUST BE CONSIDERED A COMBUSTIBLE SURFACE.

6. **DO NOT INSTALL THIS STOVE IN A MOBILE HOME, MANUFACTURED HOME, TRAILER OR TENT – NO EXCEPTIONS! (HUD Federal Standard: 24 CFR Ch.XX)**
7. The clearances provided are minimum dimensions determined by the NFPA. Installation of this stove must comply with the latest edition of NFPA 211 and/or your local building code rulings. Use whichever minimum dimensions are LARGEST.

Clearances listed and shown **MUST** be adhered to for safe operation of this appliance. **CLEARANCES MAY NOT BE REDUCED BY ANY MEANS.**

continued on next page

LOCATING STOVE continued...

Failure to follow these minimum clearance requirements may result in an unsafe installation and could cause a fire.

8. This stove is NOT a UL listed stove.

CAUTION: KEEP FURNISHINGS AND OTHER COMBUSTIBLE MATERIALS AWAY FROM THE STOVE.

WARNING: DO NOT USE SINGLE WALL CONNECTOR PIPE AS A CHIMNEY - A HOUSE FIRE COULD RESULT.

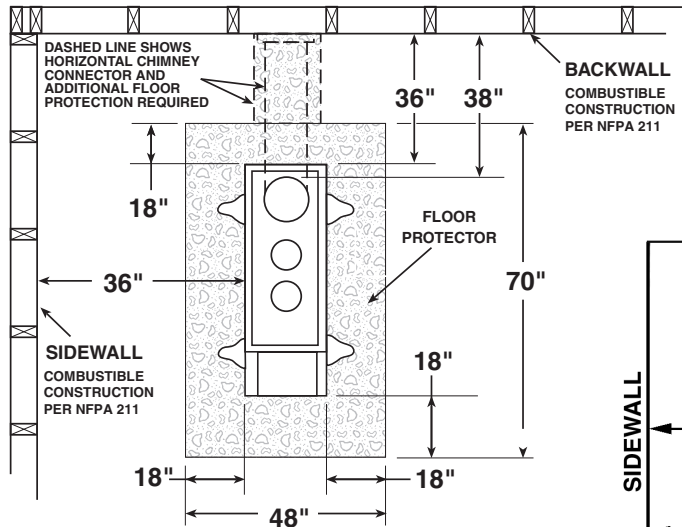

Figure 1 – Top View Minimum Clearance Dimensions from Combustible Surfaces

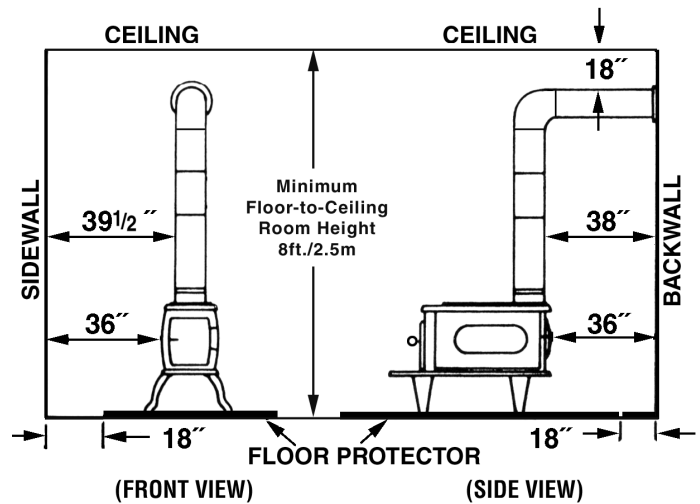

Figure 2 – Minimum Clearance Dimensions from Combustible Surfaces

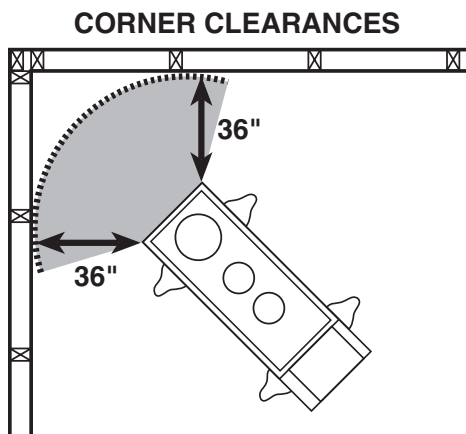

Figure 3 – Top View Minimum Corner Clearances from Combustible Surfaces

MINIMUM CLEARANCES TO COMBUSTIBLE SURFACES

Unit to Sidewall	36 inches
Unit to Backwall	36 inches
Unit Corner to Wall	36 inches
Pipe Connector to Backwall.....	38 inches
Pipe Connector to Ceiling.....	18 inches

CAUTION: KEEP FURNISHINGS AND OTHER COMBUSTIBLE MATERIALS AWAY FROM THE STOVE.

CONNECTOR PIPE INSTALLATION

NOTE: CONNECTOR PIPE IS *NOT INCLUDED*. TO PURCHASE, VISIT YOUR LOCAL HARDWARE, HOME, OR BUILDING CENTER. SEE "LOCATING STOVE" PAGE 6 & 7 FOR ADDITIONAL SPECIFICATIONS.

Connector pipe is used to make the connection from the final positioning of your stove to an approved chimney. Connector pipe is **NOT** included as part of the stove. Connector pipe must be 6"/152mm diameter minimum of 24 MSG (minimum standard gauge) black or 26 MSG blue steel stove pipe. Any connector pipe used must be in good condition. Replace if necessary before using stove. Connector pipe is not rated to provide close contact to combustible materials and must have proper clearance from combustible materials as shown in the clearance diagrams on the previous pages. Connector pipe should never be used in place of a chimney. If proper clearances are not observed a house fire could result.

Installation Instructions

1. The smooth end of the stovepipe fits over the stove flue collar. Secure with three (3) sheet metal screws. The first section of connector pipe must be single walled to properly attach to the stove collar. Install additional pipe and elbow with the crimped end towards the stove. This will allow any condensation in the flue to run back into the firebox.

2. Horizontal pipe runs must slope upwards towards the chimney at least 1/4"(6.4mm) per foot of horizontal run.
3. You must have at least 18"/457mm of clearance between any horizontal piping and the ceiling.
4. The pipe cannot extend into the chimney flue (figure 4).
5. Secure pipe/elbow sections with three sheet metal screws at each joint to make the piping rigid. Screws may be no more than a maximum of 3"/76mm apart.
6. It is recommended that no more than two (2) 90° bends be used in the stovepipe installation. The use of more than two 90° bends may decrease the amount of draw and possibly cause smoke spillage. Where possible, use only corrugated (non adjustable) elbows. These provide a better seal.
7. The connector pipe must not pass through an attic or roof space, trusses, closet, or any concealed space, floor, ceiling, wall, or combustible construction. (See Chimney Connector Systems & Clearances, page 17.) A manufactured chimney system listed to UL 103 HT must be used from the first penetration of ceiling or wall to the chimney cap.

WARNING: DO NOT USE SINGLE WALL CONNECTOR PIPE AS A CHIMNEY - A HOUSE FIRE COULD RESULT.

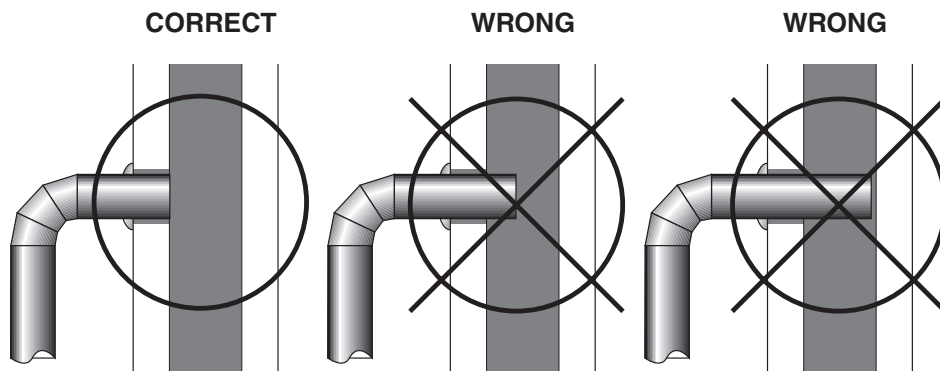

Figure 4 – Stovepipe/Flue Connections

CHIMNEY CONNECTIONS

The stove must be connected to either a lined masonry or manufactured metal chimney built and tested to the specifications listed on the previous pages.

Chimneys perform two functions:

- 1). As a means of exhausting smoke and flue gases which are the result of fuel combustion.
- 2). The chimney (only) provides "draft" which allows oxygen to be continuously introduced into the appliance, so that proper combustion is possible. This stove relies on natural draft to operate.

NOTICE: Always provide a source of fresh air into the room where the stove is located. Failure to do so may result in air starvation of other fuel burning appliances and the possible development of hazardous conditions.

A stove **DOES NOT** create draft. **Draft is provided by the chimney.** To achieve proper draft your chimney must meet the four minimum height requirements detailed in figures 6–8. **If these minimum requirements are not met your stove will not operate properly.** A minimum of 0.05 w.c. (measured in water column) is required for proper drafting to prevent back puffing, smoke spillage, and to maximize performance. (Gauges to measure draft are readily available at stove stores and are economical to rent or purchase.)

Factors such as wind, barometric pressure, trees, terrain and chimney temperature can have an adverse effect on the draft. The manufacturer cannot be held responsible for external factors leading to less than optimal drafting.

Should you have a problem with inadequate draft, you should contact a licensed heating and cooling contractor for assistance in solving the problem.

IMPORTANT Installation Points

1. Size chimney flue to stove collar. This stove requires a minimum of a 6"/152mm diameter flue.
2. Never connect this unit to a chimney serving another appliance.
3. The chimney must meet all minimum height requirements.
4. Never use a chimney to ventilate a cellar or basement.
5. Contact your local building authority for approved methods of installation and any necessary permits and/or inspections.

Masonry Chimney

Before using an existing masonry chimney, clean the chimney, inspect the flue liner and make any repairs needed to be sure it is safe to use. Make repairs before attaching the stove. The connector stove pipe and fittings you will need to connect directly to a lined masonry chimney are shown in figure 5.

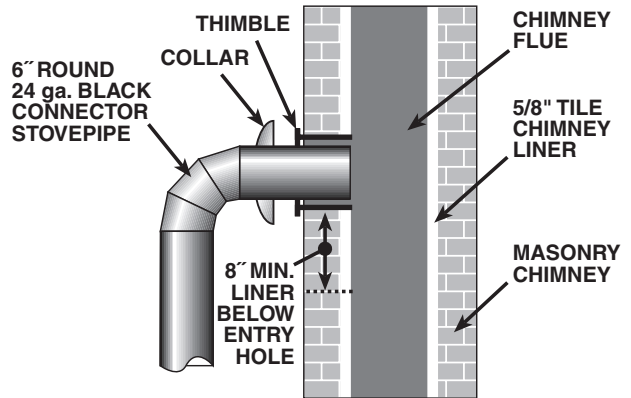

Figure 5 - Masonry Chimney Connection

If the connector stove pipe must go through a combustible wall before entering the masonry chimney, consult a qualified mason or chimney dealer. The installation must conform to local building and fire codes and latest edition of NFPA 211.

If there is a clean out opening in the base of the chimney, close it tightly.

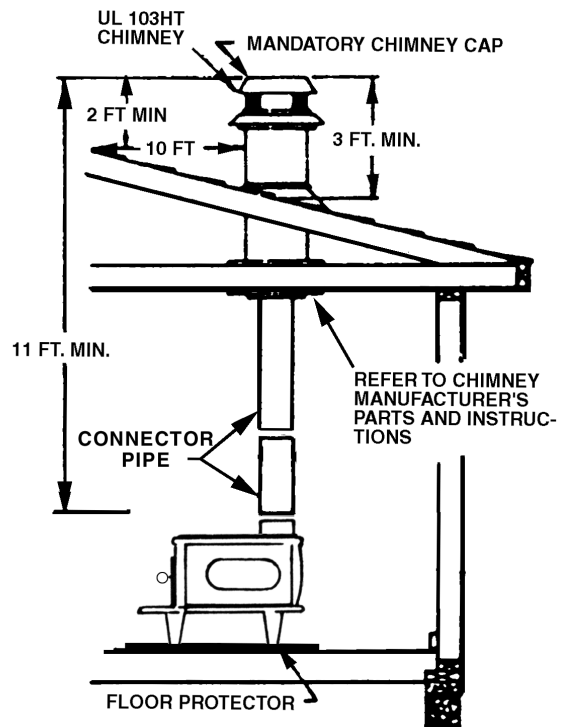

Figure 6 - Chimney Construction through Attic Space

CHIMNEY CONNECTIONS *continued ...*

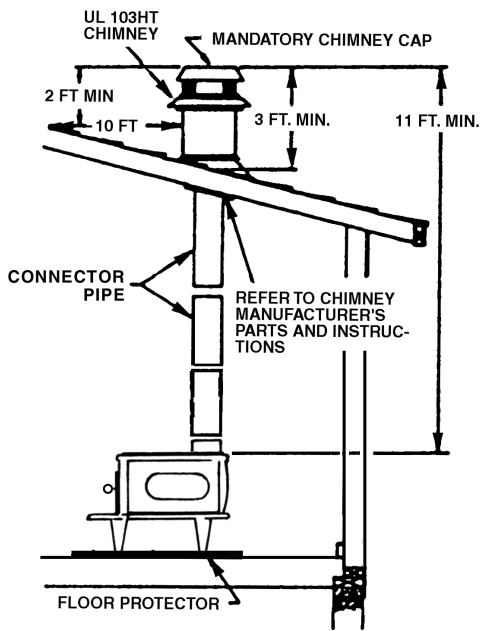

Figure 7 - Chimney Construction Through Roof

Chimney Minimum Height Requirements:

- (1) Overall Height – 11 ft./3.35m min.
- (2) Height above roof – 3 ft./91cm
- (3) Height above slope – 2 ft./61cm min. within 10 ft./3.05m
- (4) Minimum rise before horiz. section – 24 in./61cm

NOTICE: If minimum chimney requirements are not met, your stove will not operate properly.

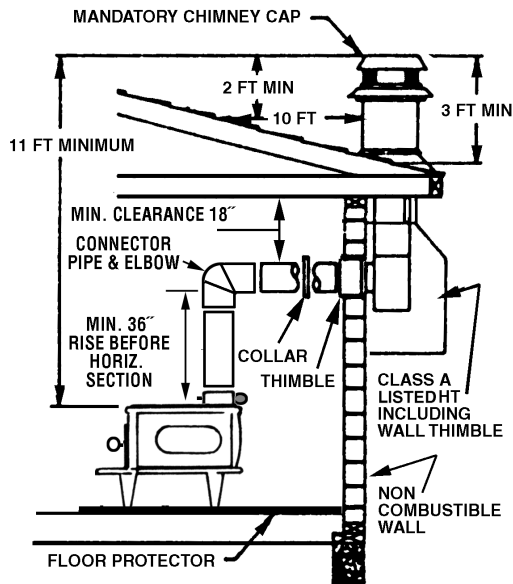

Figure 8 - Chimney Connection to Firebox Through Masonry Wall

MANUFACTURED CHIMNEY

REFER TO CHIMNEY AND CHIMNEY CONNECTOR MAKER'S INSTRUCTIONS FOR INSTALLATION AND USE.

Use only 6" diameter chimney listed to UL 103 HT. Chimney made to this listing is High Temperature rated to 2100 degrees Fahrenheit. **USE CHIMNEY FROM ONLY ONE MANUFACTURER. NEVER MIX BRANDS.** Carefully follow the chimney manufacturer's stated requirements and clearances. Use the chimney manufacturer's attic guards, roof supports, flashing and fire stops when passing through a ceiling. Use a listed thimble when passing through a combustible wall. Do not use makeshift compromises during installation.

WARNING: DO NOT USE A SINGLE-WALL CONNECTION PIPE AS A CHIMNEY!

When using a pre-existing chimney, have it's condition and installation inspected before using. Make sure that the chimney meets all of the UL rating requirements listed above. Be aware that not all manufactured chimney is of the UL 103 HT type.

NOTE: It is recommended that you contact a licensed heating and cooling contractor (consult your local yellow pages) for chimney installation.

Manufactured chimney with the proper required UL listing is available from most home centers, hardware stores, and HVAC supply stores.

If you have access to the internet, you may wish to view chimney manufacturers' information on-line. See, www.duravent.com, www.selkirkinc.com, or www.mtlfab.com.

VENTING TO EXISTING FIREPLACE

In some instances, people desire to convert an existing fireplace for stove use. Usually, safe connection to an existing masonry chimney requires more work than using a prefabricated chimney. The existing fireplace must be closed and sealed at the damper with high-temperature caulk, ceramic wool, or furnace cement. Prior to installation, clean and inspect the existing flue and smoke shelf. Installation should be designed so the system can be dismantled for periodic cleaning and inspection. **Before conversion, make sure the existing chimney is structurally sound, the chimney incorporates a flue liner and make sure it is in good condition.** (A flue liner consists of clay tile that protects the brickwork of a chimney. If a chimney does not have a liner, or it is damaged, have it relined by a professional. **DO NOT use a chimney that is unlined or damaged!**) If you have any question regarding the condition of the chimney, consult a qualified licensed contractor, qualified engineer, competent mason, certified Chimney Sweep, or a knowledgeable inspector. Consult your insurance company if you cannot find a qualified expert.

continued on next page

CHIMNEY CONNECTIONS *continued ...*

CAUTION: NOT ALL FIREPLACE CHIMNEYS ARE SUITABLE FOR CONVERSION TO ACCOMMODATE CONNECTION TO A WOOD STOVE. CHECK WITH A QUALIFIED EXPERT.

Many prefabricated fireplaces are of the “zero-clearance fireplace” category. These consist of multi layered metal construction. They are designed with enough insulation and/or air cooling on the base, back and sides so they can be safely installed in direct contact with combustible floors and walls. Although many prefabricated fireplaces carry endorsements from nationally recognized organizations for use as fireplaces, they have not been tested for connection to wood stove heaters. Connecting a stove to such a device will void the manufacturer’s warranty.

Venting a stove directly into a fireplace does not meet code and should not be attempted. The stove warranty will be void with such an installation. Do not create a hazard in your home by connecting in this manner.

FIREPLACE INSTALLATION

NOTE: DO NOT ATTEMPT TO ROUTE THE CHIMNEY CONNECTOR PIPE THROUGH THE THROAT OF THE FIREPLACE.

Directly connecting the stovepipe into the existing masonry chimney (figure 9, Type A Fireplace Conversion) of the fireplace is the ONLY approved method of installation. This is a complicated and involved process and to ensure safety should only be done by a qualified installer.

1. An entry hole must be cut through the masonry and tile liner with minimal damage to the liner. At least 8”/203mm of liner must remain below the entry position. When locating the stove and stovepipe, all minimum clearances must be observed from combustible surfaces including mantels, combustible

trim work, ceilings, and walls. Positioning the center of the stove pipe entry into the chimney 24”/61cm below the ceiling should insure proper clearance for a 6”/152mm stovepipe.

2. Install a metal or fire clay (5/8”/16mm minimum thickness) thimble. Make sure the thimble is flush with the inner surface of the chimney liner and does not protrude into the flue (see figure 5 on page 9).
3. Secure the thimble with refractory mortar. The thimble should be surrounded by 12”/305mm of solid unit masonry brickwork or 24”/61cm of stone.
4. Install the stovepipe into the thimble as far as possible without extending past the flue lining (see figures 4 & 5 on pages 8 & 9).
5. A small airspace (about 1/2”/13mm) should remain between the stovepipe and thimble to allow for expansion of the pipe. Seal this airspace with high-temperature caulking or ceramic wool.
6. Secure and seal the damper in the closed position using high-temp caulking, ceramic wool, or furnace cement. Also check to see if the chimney has a clean out. If it does, make sure it is closed and sealed as well. A leaky clean out will greatly reduce draft efficiency.

If you have any questions regarding venting your stove, contact the manufacturer or contact the National Fire Protection Association (NFPA) and request a copy of the latest editions of NFPA Standard 211 and NFPA Standard 908. Their address is:

Battery March Park, Quincy, MA 02269.

TYPE A FIREPLACE CONVERSION

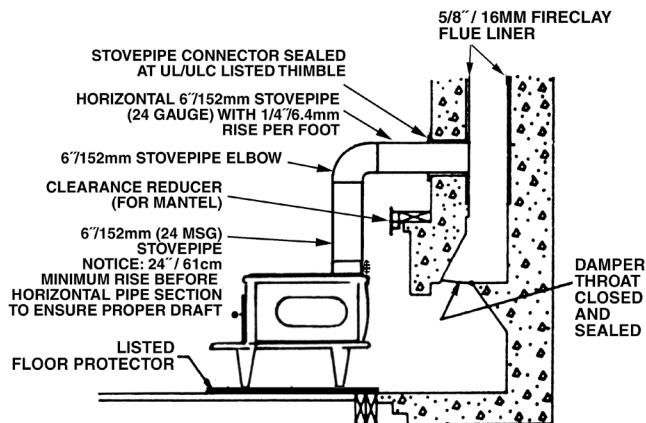
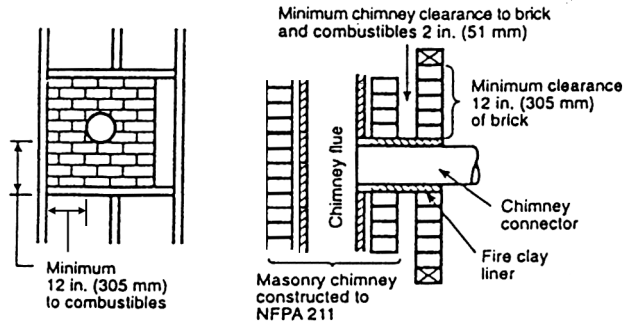

Figure 9 - Fireplace Conversion

CHIMNEY CONNECTOR SYSTEMS & CLEARANCES

NOTE: IN CANADA, THE INSTALLATION MUST CONFORM TO CAN/CSA-B365 WHEN PASSING THROUGH COMBUSTIBLE CONSTRUCTION.



A. Brick Masonry

Minimum 3.5" / 89mm thick brick masonry all framed into combustible wall with a minimum of 12" / 305mm brick separation from clay liner to combustibles. The fireclay liner shall run from outer surface of brick wall to, but not beyond, the inner surface of chimney flue liner and shall be firmly cemented in place.

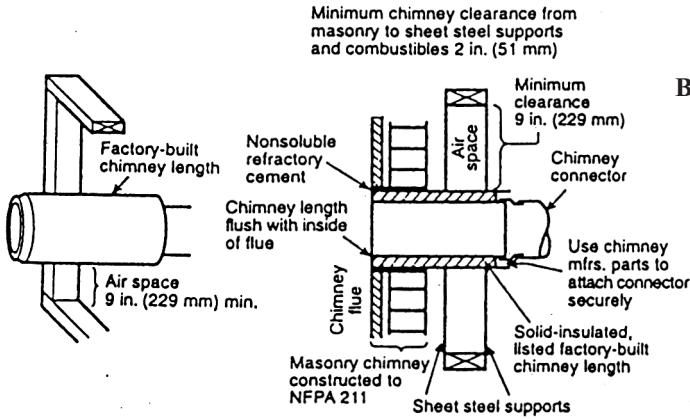

B. Insulated Sleeve

Solid-insulated, listed factory-built chimney length of the same inside diameter as the chimney connector and having 1" / 25.4mm or more of insulation with a minimum 9" / 229mm air space between the outer wall of the chimney length and combustibles.

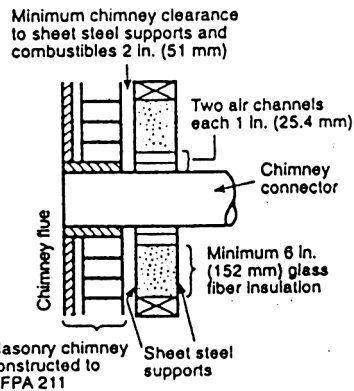

C. Ventilated Thimble

Sheet steel chimney connector, minimum 24 gauge in thickness, with a ventilated thimble, minimum 24 gauge in thickness, having two 1" / 25.4mm air channels, separated from combustibles by a minimum of 6" / 152mm of glass fiber insulation. Opening shall be covered, and thimble supported with a sheet steel support, minimum 24 gauge in thickness.

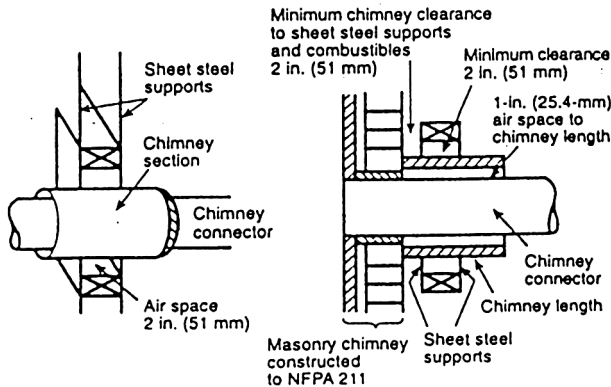
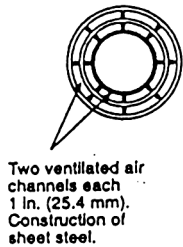

D. Chimney Section Pass-through

Solid insulated, listed factory-built chimney length with an inside diameter 2" / 51mm larger than the chimney connector and having 1" / 25.4mm or more of insulation, serving as a pass-through for a single wall sheet steel chimney connector of minimum 24 gauge thickness, with a minimum 2" / 51mm air space between the outer wall of chimney section and combustibles. Minimum length of chimney section shall be 12" / 305mm chimney section spaced 1" / 25.4mm away from connector using sheet steel support plates on both ends of chimney section. Opening shall be covered, and chimney section supported on both sides with sheet steel support securely fastened to wall surfaces of minimum 24 gauge thickness. Fasteners used to secure chimney section shall not penetrate chimney flue liner.

OPERATING INSTRUCTIONS

CAUTION: HOUSE FIRE HAZARDS

- DO NOT STORE WOOD ON FLOOR PROTECTOR, UNDERNEATH STOVEPIPE, OR ANYWHERE WITHIN MINIMUM CLEARANCES FROM COMBUSTIBLE SURFACES SPECIFIED FOR THIS STOVE.
- OVER FIRING MAY CAUSE A HOUSE FIRE. YOU ARE OVER FIRING IF A UNIT OR CHIMNEY CONNECTOR GLOWS RED.

OPERATING SAFETY PRECAUTIONS

1. NEVER OVER FIRE THIS STOVE BY BUILDING EXCESSIVELY HOT FIRES AS A HOUSE/BUILDING FIRE MAY RESULT. YOU ARE OVER FIRING THE STOVE IF UNIT OR STOVEPIPE BEGINS TO GLOW OR TURN RED.
2. NEVER BUILD EXTREMELY LARGE FIRES IN THIS TYPE OF STOVE AS DAMAGE TO THE STOVE OR SMOKE LEAKAGE MAY RESULT
3. UNIT IS HOT WHILE IN OPERATION. KEEP CHILDREN, CLOTHING, AND FURNITURE AWAY. CONTACT MAY CAUSE SKIN BURNS. DO NOT TOUCH THE STOVE AFTER FIRING UNTIL IT HAS COOLED.
4. PROVIDE AIR INTO THE ROOM FOR PROPER COMBUSTION.
5. INSPECT STOVEPIPE EVERY 60 DAYS. REPLACE IMMEDIATELY IF STOVEPIPE IS RUSTING OR LEAKING SMOKE INTO THE ROOM.

WARNING: EXPLOSION HAZARD

- DO NOT USE CHEMICALS OR FLUIDS TO START THE FIRE.
- NEVER USE GASOLINE, GASOLINE-TYPE LANTERN FUEL, KEROSENE, CHARCOAL LIGHTER FLUID, OR SIMILAR LIQUIDS TO START OR 'FRESHEN-UP' A FIRE IN THIS HEATER. KEEP ALL SUCH LIQUIDS WELL AWAY FROM THE HEATER WHILE IT IS IN USE.
- KEEP ALL FLAMMABLE LIQUIDS, ESPECIALLY GASOLINE, OUT OF THE VICINITY OF THE STOVE — WHETHER IN USE OR IN STORAGE.

THIS STOVE IS DESIGNED TO BURN WOOD FUEL ONLY!

Hardwood, 18" to 20" (46 to 50 cm) should be air dried (seasoned), for a minimum of 6 months. Logs greater than 6" (152mm) in diameter should be split. Wood should be stored in a dry, well ventilated area. The humidity content for usable firewood must be less than 20% of the weight of the log.

Attempts to use wet or unseasoned wood will cause:

- ignition problems
- rapid creosote build-up resulting in chimney fire
- incomplete combustion
- low heat yield

NOTICE: USE SOLID WOOD MATERIALS ONLY. DO NOT BURN GARBAGE, CHARCOAL OR FLAMMABLE FLUIDS SUCH AS GASOLINE, NAPHTHA OR ENGINE OIL. DO NOT USE COAL. THIS STOVE IS NOT DESIGNED TO ACCOMMODATE THE AIR FLOW (DRAFT) NECESSARY TO PROPERLY BURN COAL OR COAL PRODUCTS.

NOTE: A 2" / 51mm layer of sand or a layer of firebrick should be used as bottom insulation in the Boxwood stove. An optional cast iron grate, 26G, may be used instead of firebrick or sand. See Accessory Sheet included with this manual or visit www.vogelzang.com for ordering information.

STARTING A FIRE

1. Open collar draft damper fully to provide maximum draft.
2. Open the feed door and place several wads of crushed paper in the firebox.
3. Lay small stacks of kindling on the paper to start the fire.
4. Light the paper and kindling, close the door and secure tightly.
5. Add fuel after fire is burning briskly. Use care not to smother the kindling fire when adding wood. Close the door and secure tightly.
6. Adjust the collar draft damper and hearth slide draft control. The more closed the slide draft is set, the lower and slower the fire will burn. The more open, the faster and hotter the fire will burn. Do not over fire the stove.

continued on next page

OPERATING INSTRUCTIONS *continued ...*

NOTICE - INITIAL BURNS to Cure PAINT

Because of the high operating temperatures, this stove uses a special high-temp paint which requires a series of burns to cure the paint for durability and a lifetime of service.

Proper curing of the high-temp paint requires a series of three initial burns. The stove should be allowed to cool off between each burn. The first two burns should be small fires and low temperatures (250°F/120°C) for a duration of 20 minutes each. The third fire should be at a medium-high temperature (500 to 700°F/260 to 370°C) for twenty minutes. Provide adequate cross ventilation to clear any smoke or odor caused by initial firings.

ADDING FUEL

Add small amounts of fuel each hour or so instead of piling large quantities of fuel at one time. This will ensure a more complete combustion process and less buildup of tars, soot, or creosote will occur in the chimney.

1. Always open collar draft damper before opening the feed door.
2. When adding fuel be careful not to smother the fire. Do not build fires against the door. Do not load fuel to a height or in such a manner that it creates a hazard when opening the door.
3. Close the feed door and secure tightly.
4. Adjust the damper and slide draft control to achieve desired burn rate.
5. Empty ashes regularly. Do not allow ashes to pile up higher than the top lip of the hearth plate (see Safety Instructions, item #14, page 2. If ashes build up to the grate, burnout will occur.
6. Properly dispose of hot ashes (see Safety Instructions, item #14 on page 2.)
7. Do not over fire the stove. Over firing is when any part of the stove exterior or chimney connections glow.

CAUTION: DO NOT OVER FIRE STOVE. YOU ARE OVER FIRING IF THE CHIMNEY CONNECTORS OR STOVE GLOWS RED. IMMEDIATELY CLOSE THE DOOR, DAMPER, AND SLIDE DRAFT TO REDUCE THE AIR SUPPLY AND SLOW DOWN THE FIRE. TOO MUCH WOOD OR BURNING NON-RECOMMENDED MATERIALS SUCH AS TRASH OR FLAMMABLE LIQUIDS MAY CAUSE OVER FIRING.

CAUTION: SLOW BURNING FIRES AND EXTENDED USE MAY CAUSE EXCESSIVE CREOSOTE BUILDUP. IGNITION OF CREOSOTE BUILDUP OR OVER FIRING MAY CAUSE A CHIMNEY FIRE. CHIMNEY FIRES BURN EXTREMELY HOT AND MAY IGNITE SURROUNDING MATERIALS. IN CASE OF A CHIMNEY FIRE IMMEDIATELY LEAVE THE BUILDING AND CALL THE FIRE DEPARTMENT FROM A SAFE LOCATION.

CREOSOTE – FORMATION AND NEED FOR REMOVAL

CAUTION: RISK OF FIRE When wood is burned slowly, it produces tar and other organic vapors, which combine with expelled moisture to form creosote. The creosote vapors condense in the relatively cool chimney flue of a slow-burning fire. As a result, creosote residue accumulates on the flue lining. When ignited this creosote makes an extremely hot fire.

The chimney connector and chimney should be inspected at least once every two months during the heating season to determine if a creosote buildup has occurred.

If creosote has accumulated (3mm or more) it should be removed to reduce the risk of a chimney fire.

Failure to remove creosote may result in ignition and may cause a house/building fire. Creosote may be removed using a chimney brush or other commonly available materials from your local hardware retailer.

Chimney fires burn very hot. If the unit or chimney connector should glow red, reduce the fire by closing the inlet air control and immediately call the fire department.

CAUTION: A CHIMNEY FIRE MAY CAUSE IGNITION OF WALL STUDS OR RAFTERS WHICH WERE ASSUMED TO BE A SAFE DISTANCE FROM THE CHIMNEY. IF A CHIMNEY FIRE HAS OCCURRED, HAVE YOUR CHIMNEY INSPECTED BY A QUALIFIED EXPERT BEFORE USING AGAIN.

A fire in the firebox may be smothered by pouring a large quantity of coarse salt, baking soda, or cool ashes on top of the fire.

continued on next page

MAINTENANCE & SERVICE HINTS

PREVENTING CREOSOTE BUILDUP

1. Creosote will inevitably form in your chimney and connector pipe. Following these steps will help reduce the rate of build up.
2. **BURN ONLY SEASONED WOOD** that has dried for at least one year. (<20% humidity by weight)
3. Burn hardwood rather than softwood. Hardwood is denser or heavier wood and burns hotter.
4. Do not attempt to burn (or mix in) green or wet wood. The use of green or wet wood will cause a rapid build up of creosote. Wood that hisses, sizzles and blackens without igniting in five minutes must be considered too wet to burn.
5. Do not attempt to extend the burn time by using wet wood. Not only does burning wet wood rapidly build up creosote, but it reduces the heat output by up to 25 percent.
6. Do not load more than $\frac{1}{4}$ to $\frac{1}{2}$ of the fuel capacity at one time. Loading too much wood at once will cause excessive smoke which contains creosote. Mature fires or coals produce very little creosote-producing smoke.
7. Establish a routine for the handling of fuel, firing, and operating the stove. Check daily for creosote build up until experience shows how often you need to clean for safe operation. Be aware that the hotter the fire, the less creosote is deposited and even though monthly cleanings may be enough in the colder months, weekly cleanings may be necessary in mild weather.

WARNING: IN CASE OF CHIMNEY FIRE

- (1) CLOSE SLIDE DRAFT & FLUE DAMPER CONTROLS
- (2) GET OUT OF THE HOUSE
- (3) CALL THE FIRE DEPARTMENT.

IF A CHIMNEY FIRE HAS OCCURRED, HAVE YOUR CHIMNEY INSPECTED BY A QUALIFIED EXPERT BEFORE USING AGAIN.

ASH DISPOSAL – Do not allow ashes to accumulate higher than the optional grate. Dispose of properly. (See Safety Instructions #14, page 2.)

CHIMNEY DRAFT – Draft is a function of the chimney, not the stove — do not expect the stove to draw. Smoke spillage into the house or excessive buildup of condensation or creosote in the chimney are warnings that the chimney is NOT functioning properly. Correct the problem before using the stove. Following are some possible causes for improper draft.

1. The connector stovepipe may be pushed into the chimney too far, stopping the draft.

2. If the chimney temperature is too cool, water will condense in the chimney and run back into the stove. Creosote formation will be rapid and may block the chimney. Operate the stove at a fire level high enough to keep the chimney warm to prevent condensation from forming.

3. If the fire burns well but sometimes creates excess smoke or burns slowly, it may be caused by the chimney top being lower than another part of the house or a nearby tree. The wind blowing over a house or tree, falls on top of the chimney like water over a dam, beating down the smoke. The top of the chimney should be at least three (3) feet above the roof and be at least two (2) feet higher than any point of the roof within ten (10) feet.

CHIMNEY INSPECTIONS – The chimney connector and chimney should be inspected **at the beginning** of and **at least twice a month during** the heating season to determine if a creosote buildup has occurred.

STOVE JOINTS

Required Tune-up. This stove is manufactured with cast iron components. **IT DOES NOT HAVE WELDED SEAMS.** Periodic “tune up” may be required by refilling and/or replacing the cement/joint mortar along the seams where the cast iron components meet.

ORDERING PARTS - BX26E BOXWOOD STOVE

When ordering missing or replacement parts, always give the **Model Number** of the stove, **Part Number**, and **Part Description**. Use the illustration and parts list provided to identify parts.

Part No.	Description	Qty.
1	Leg.....	4
2	Bottom	1
3	Side	2
4	Back.....	1
5	Slide Draft Damper	1
6	Front	1
7	Feed Door.....	1
8	Top	1
9	Swing Top	1
10	Lid.....	2
11	Lid Support	1
12	Hearth.....	1
13	Damper Collar Assembly	1
14	Door Handle Assembly	1
15	Lid Lifter (L-1)	1
16	Hardware Pack, Complete	1
17	S-Hook (used to hang lid lifter)	1
18	Door Latch	1
19	Retainer Bolts	4

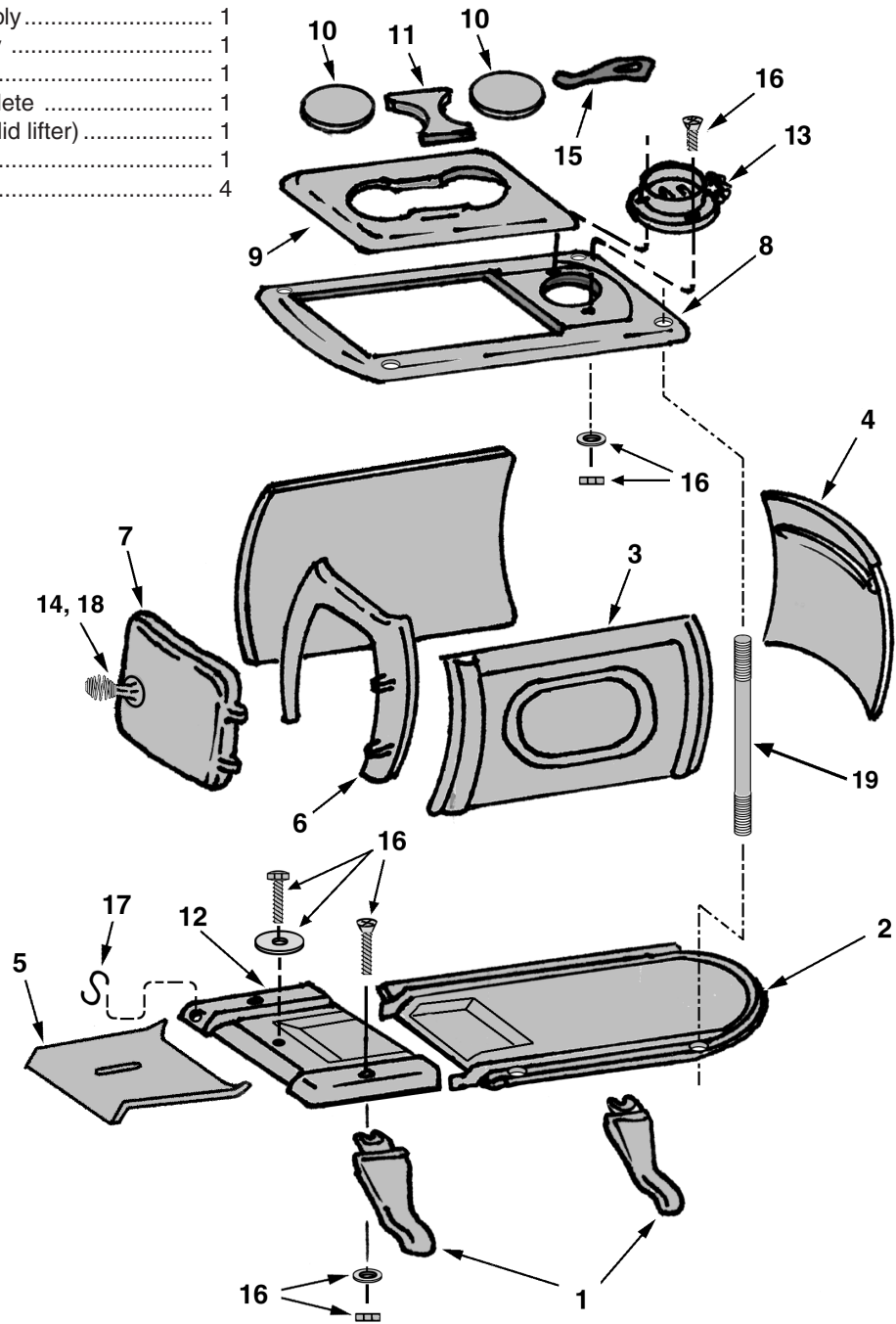

FLOOR PROTECTOR MATERIAL CALCULATIONS

This stove has been tested for and must be installed on a floor protector with the proper Thermal Resistance or R-value as stated in the installation instructions under, “Locating Stove” step 1, of this manual. If the floor protector materials listed in the instructions are not available, materials with an equivalent R-value may be substituted.

Alternate materials may be rated with C-factor (Thermal Conductance) or k-factor (Thermal Conductivity) ratings which must be converted to R-value to determine if the alternate material meets the tested requirements. The following instructions provide the proper information and formulas for conversion to R-value.

To determine if alternate materials are acceptable follow this sequence.

1. Convert material specifications to R-value:
 - a. R-value given — no conversion necessary
 - b. k-factor is given with a required thickness (T) in inches:

$$R = 1/k \times T$$
 - c. C-factor is given: $R = 1/C$
2. Determine the R-value of proposed alternate floor protector:
 - a. Use formulas in step 1 above to calculate R-value of proposed material(s).
 - b. For multiple layers, add R-values of each layer to determine overall R-value.
3. If the overall R-value of the floor protector system is equal to or greater than the floor protector specifications given, the alternate is acceptable.

Definitions:

$$\text{Thermal conductance (C)} = \frac{\text{BTU}}{(\text{hr})(\text{ft}^2)(\text{°F})} = \frac{\text{W}}{(\text{m}^2)(\text{°K})}$$

$$\text{Thermal conductivity (k)} = \frac{(\text{Btu})(\text{inch})}{(\text{hr})(\text{ft}^2)(\text{°F})} = \frac{\text{W}}{(\text{m})(\text{°K})} = \frac{\text{Btu}}{(\text{hr})(\text{ft})(\text{°F})}$$

$$\text{Thermal resistance (R)} = \frac{(\text{ft}^2)(\text{hr})(\text{°F})}{\text{Btu}} = \frac{(\text{m}^2)(\text{°K})}{\text{W}}$$

Example:

The specs of floor protector material should be 3/4-inch thick material with a k-factor of 0.84. The proposed alternative material is 4” brick with a C-factor of 1.25 over 1/8-inch mineral board with a k-factor of 0.29.

Step 1: Convert specs to R-value.

$$R = 1/k \times T = 1/0.84 \times 0.75 = 0.893 \quad \text{System must have a R-value of } 0.893 = R_{\text{specs}}$$

Step 2: Calculate R-value of individual components

$$4'' \text{ Brick with C-factor} = 1.25. \quad R = 1/C = 1/1.25 = 0.80 = R_{\text{brick}}$$

$$1/8\text{-inch (0.125'')} \text{ mineral board with k-factor} = 0.29. \quad R = 1/0.29 \times 0.125 = 0.431 = R_{\text{min.brd.}}$$

Step 3: Add R-values of components to get total R-value of system

$$R_{\text{brick}} + R_{\text{min.brd}} = 0.80 + 0.431 = 1.231 = R_{\text{system}}$$

Step 4: Compare R_{system} to R_{specs}

R_{system} = 1.231 is larger than R_{specs} of 0.893. System R-value exceeds the required specifications and therefore is an acceptable alternative.

This Vogelzang heating appliance is safe when installed properly and will provide you with years of service. However, always exercise good judgement when you are using this stove. You are dealing with FIRE! Fire is inherently dangerous and must be treated with respect. Stay warm and in good health!

Respectfully yours,

Steve Vogelzang

Proprietor

**DO NOT INSTALL THIS STOVE IN A
MOBILE HOME, MANUFACTURED HOME,
TRAILER OR TENT — NO EXCEPTIONS!**

COMPANY TESTIMONY:

“FOR GOD SO LOVED THE WORLD THAT HE GAVE HIS ONLY BEGOTTEN SON, THAT WHOEVER BELIEVES IN HIM SHALL NOT PERISH BUT HAVE ETERNAL LIFE”

JOHN 3:16

MADE IN CHINA

VOGELZANG

International CORPORATION



Vogelzang International Corporation
400 West 17th Street
Holland, Michigan 49423
www.vogelzang.com
Phone: 1-616-396-1911
Fax: 1-616-396-1971