



Resolute Fireback Replacement Instructions

Materials Provided:

- Lower fireback
- Upper fireback w/damper and damper link attached
- 2, 1/4-20 x 1" Hex head bolts and acorn nuts
- 1, 1/4-20 x 1 1/4" Phillips flat head machine screw (Left insert)
- 1, 1/4-20 x 2" Phillips flat head machine screw (Right Insert)
- 1, Tube furnace cement

Tools Required:

- | | |
|--------------------------------|---------------------------|
| Rubber mallet or block of wood | Phillips Head Screwdriver |
| 1/4" Drill and bit | Regular screwdriver |
| Penetrating oil | 5/32" Allen wrench |
| Old vacuum cleaner | Drop light |
| | Protective eyewear |

Preparation

The installation of the Resolute two piece fireback can be accomplished by one person but it may be helpful to have an assistant. Please read through the instructions presented here to familiarize yourself with the components and the procedure.

Wear old clothes and cover the area surrounding the Resolute with newspaper or drop cloth. Clean the inside of the stove of sand and ashes (you may want to save some to reline the stove bottom when finished).

Set aside at least one hour for the removal and installation of the fireback. The job may take two or three hours to complete.

Procedure

1. Remove the griddle, flue collar, flue collar extension and front door.
2. Remove the Phillips head screw from the right insert and pry the right insert out with the large screwdriver. If the screw is difficult to remove, you can often loosen it by holding the screwdriver in place and striking it a few times with the hammer. Use of penetrating oil on hard-to-remove screws

is often helpful. Follow manufacturer's directions. Usually the oil needs to soak the threads of the screw for 10 to 15 minutes.

3. Remove the Phillips head screw from the left insert and take out the left insert.
4. Pull the fireback out, catching the damper ears and damper as you do so. Unhook the damper linkage from the damper rod.
5. Clean the remaining ashes and furnace cement front the inside of the stove. Be sure to clean the cement channels on the back of the stove and lower fireback so the new cement will adhere.
6. Cement the secondary air tube channel in the stove back. (Fig. 2)

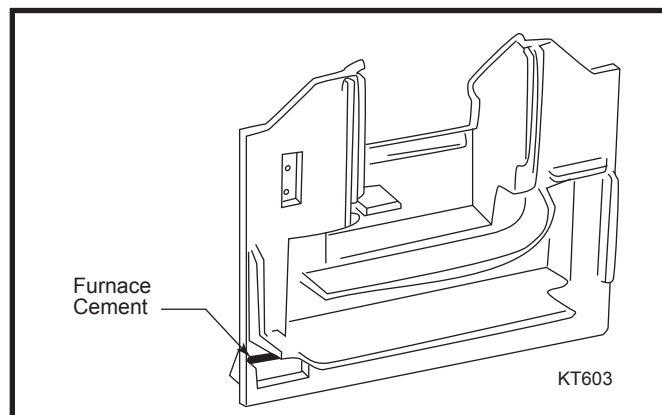

Fig. 1 Apply cement to the secondary air tube channel in stove back.

7. Cement the secondary air tube channel on the back of the lower fireback. (Fig. 3)
8. Set the new lower fireback in place.

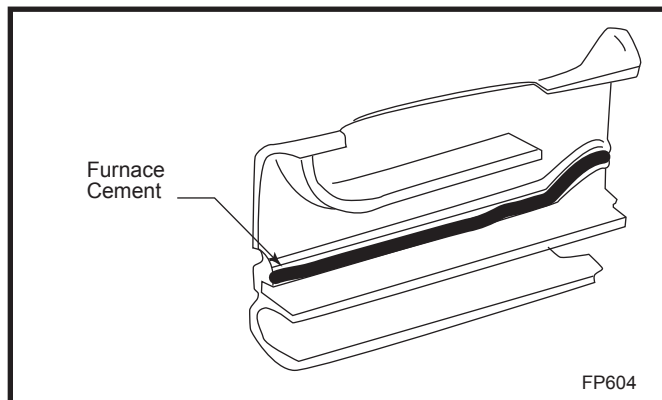
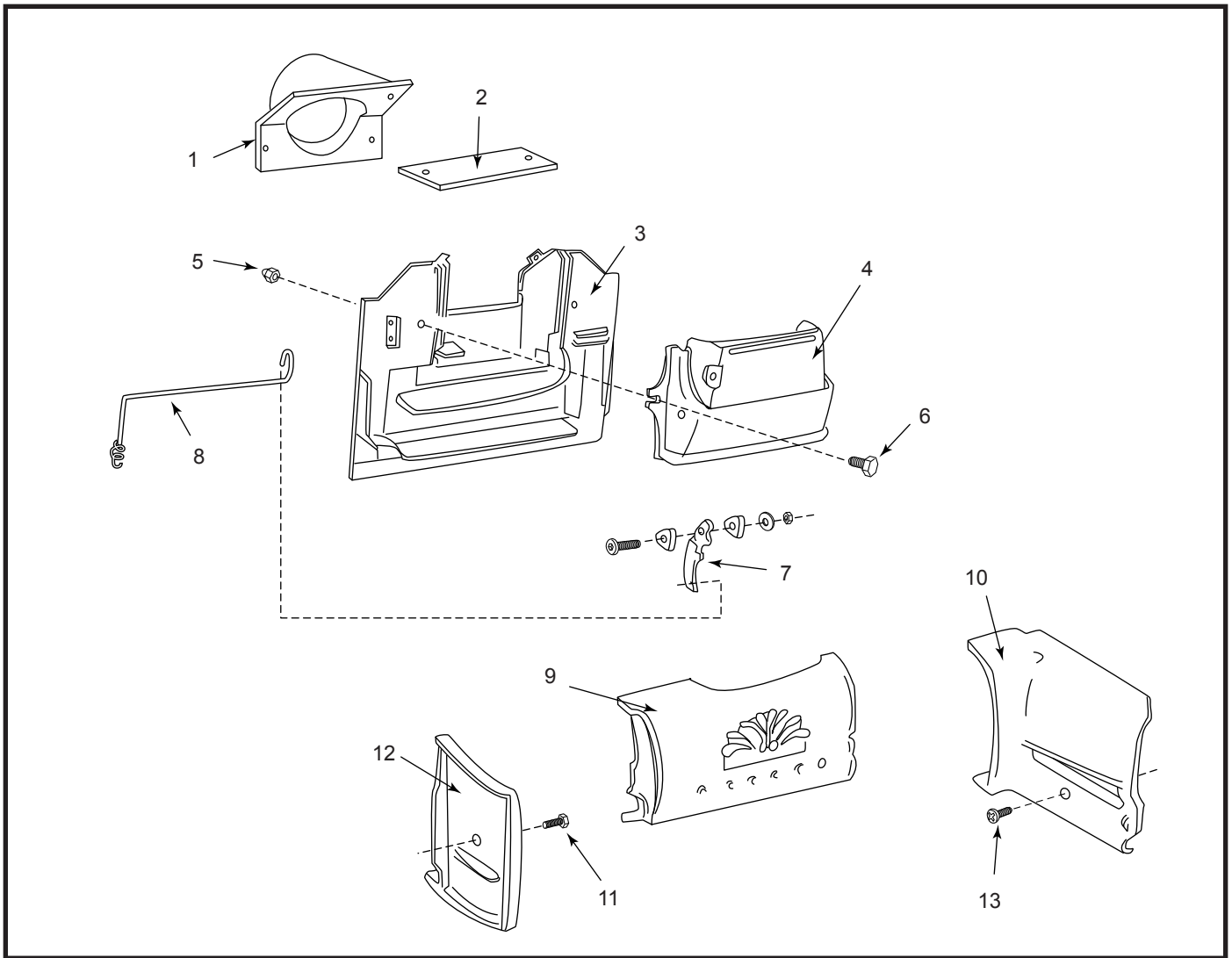

Fig. 2 Apply cement to the secondary air tube channel on the back of the lower fireback.

9. Set the left insert in place. Make sure the lower fireback is pushed all the way against the back plate. Replace the 1/4-20 x 1/4" self-tapping Phillips head screw and tighten to hold the left insert in place.
 10. Replace the right insert; it fits very tightly against the fireback so you will have to hammer it into place with the rubber mallet. Replace the 1/4-20 x 2" Phillips head screw and tighten to hold the right insert in place.
 11. Hold the upper fireback, with the damper and damper linkage attached, inside the stove. Turn the assembly to a vertical position to hook the damper link onto the damper rod (damper handle should be pointing downward). Turn the assembly clockwise to a level position to engage the damper link.
 12. Have your assistant raise the upper fireback and damper into place and raise the damper link. Hold the upper fireback securely in place on top of the lower fireback and operate the damper handle to check for free movement.
 13. Move the damper to its locked, closed position: damper up, damper handle pointing down.
 14. Wear protective eyewear for this step. Reaching in through the front door opening, hold the upper fireback and the damper firmly in place with one hand (or have your assistant hold them from behind the stove) and drill two holes through the stove back using the two slots in the upper fireback as guides for the drill bit. On the left slot, drill as close as possible to the inside of the slot so you clear the thermostat cover on the stove back. If by chance there is not enough room to tighten the acorn nut, you will have to mark the spot on the thermostat cover, remove it and grind an opening in the edge of the thermostat cover.
 15. Insert the two 1/4-20 x 1" hex bolts through the holes and tighten the acorn nuts onto them.
 16. Again, check the damper for free movement, open and closed, and into its locking position.
 17. Re-line the Resolute stove bottom with sand or ashes.
- REMEMBER:** You will have to begin a break-in procedure as described in your Operation Manual of 8 to 10 moderate fires to temper the cast iron in the replacement castings.



Resolute Parts

1. Flue Collar
2. Flue Collar Extension
3. Back
4. Upper Fireback and Damper Assembly
5. Acorn Nut
6. 1" Hex Head Bolt
7. Damper Link
8. Damper Rod
9. Lower Fireback
10. Right Insert
11. 2" Phillips Head Screw
12. Left Insert
13. 1 1/4" Phillips Head Screw

CFM Corporation

410 Admiral Blvd. • Mississauga, Ontario, Canada L5T 2N6
800-668-5323 • www.cfmcorp.com