

IMPORTANT:
THESE INSTRUCTIONS ARE TO
REMAIN WITH THE HOMEOWNER



Summit Wood Insert

INSTALLATION AND OPERATING INSTRUCTIONS

SAFETY NOTICE

If this stove is not properly installed, a house fire may result. For your safety, follow the installation directions. Consult local building or officials about restrictions and installation inspection requirements in your area.



**TESTED and LISTED
to ULC S628 / UL 1482**

Meets the U.S. Environmental Protection Agency's July 1990 Particulate Emission Standards

**MODEL
SUMMIT WOOD
INSERT
DESIGN-A**



Contents

Safety	3
Clearances	3
Masonry or Factory Built Fireplace	3
Installation	5
Fireplace Specifications	5
Into a Masonry Fireplace	5
Full Flue Liner - (Required in Canada)	6
Direct Flue Connection	6
Into a Factory Built Fireplace	6
Surround Assembly and Installation	7
Combustion Air	8
Blower	9
Blower Operation	9
Electrical Supply	9
Operation	10
Wood Selection	10
How to Test Your Wood	10
Lighting the Fire	10
Normal Operation	10
Restarting After Extended or Overnight Burns	10
More Wood, More Heat	11
Proper Draft	11
Ash Removal	11
Disposal of Ashes	11
Creosote	12
Formation and Need for Removal	12
Chimney Fires	12
In Case of a Chimney Fire	12
Avoiding a Chimney Fire	12
Maintenance	13
Baffle Removal	13
Appendix A	14
Troubleshooting	14
Firebrick Installation Instructions	15
Replacement Parts	16
Understanding & Operating Your Pacific Energy Stove	18
Label	19

Safety

READ ALL INSTRUCTIONS BEFORE INSTALLING AND USING THIS APPLIANCE. FAILURE TO FOLLOW INSTRUCTIONS MAY RESULT IN PROPERTY DAMAGE, BODILY INJURY, OR EVEN DEATH.

We strongly recommend that smoke detectors be installed. If smoke detectors have been previously installed, you may notice that they are operating more frequently. This may be due to curing of stove paint or fumes caused by accidentally leaving the fire door open. Do not disconnect the detectors. If necessary, relocate them to reduce their sensitivity.

SAFETY NOTICE: If this stove is not properly installed, a building fire may result. For your safety, follow the installation directions. Consult local building or fire officials about restrictions and installation inspection requirements in your area.

The services of competent installer, certified by the Wood Energy Technical program (WETT) - in Canada, Hearth Education Foundation (HEARTH) - in U.S.A. (or equivalent) are strongly recommended.

Clearances

Masonry or Factory Built Fireplace

The minimum required clearances to surrounding combustible materials when installed into a masonry or factory built fireplace are listed below and in figure #1.

Minimum Clearances to Combustibles (Measured From Insert Body)

Adjacent Sidewall	8.5 in. (216 mm.)
Mantel.....	21 in. (533 mm.)
Top Facing	21 in. (533 mm.)
Side Facing (1.5 in. extension)	8.5 in. (216 mm.)

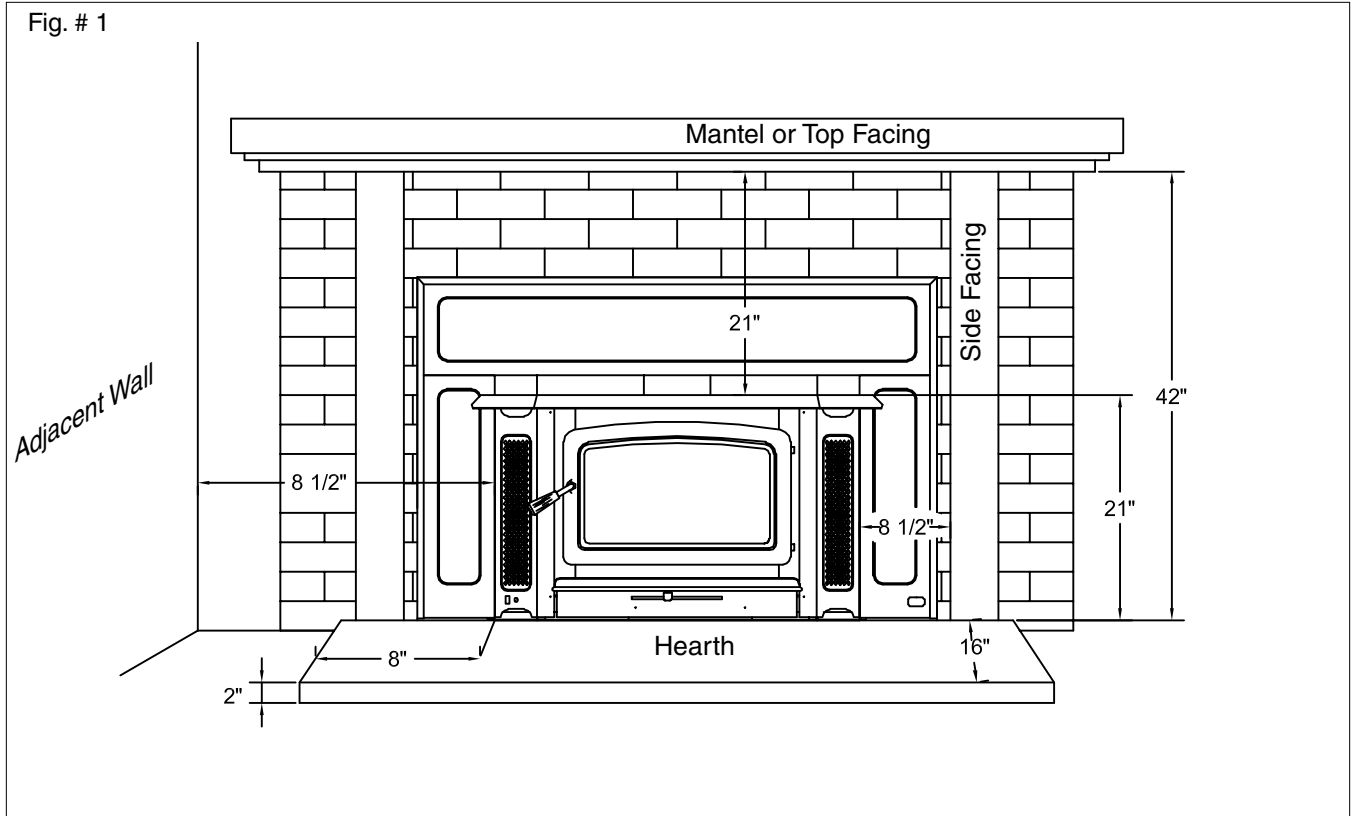

***Fireplace Hearth (measured without the insert):** The non-combustible fireplace hearth must be raised 2" above an adjacent combustible floor and extend 16" in front and 8" beyond each side of the fireplace opening. A non-combustible hearth that extends a minimum 20-1/2" in front of the fireplace opening may be flush to an adjacent combustible floor

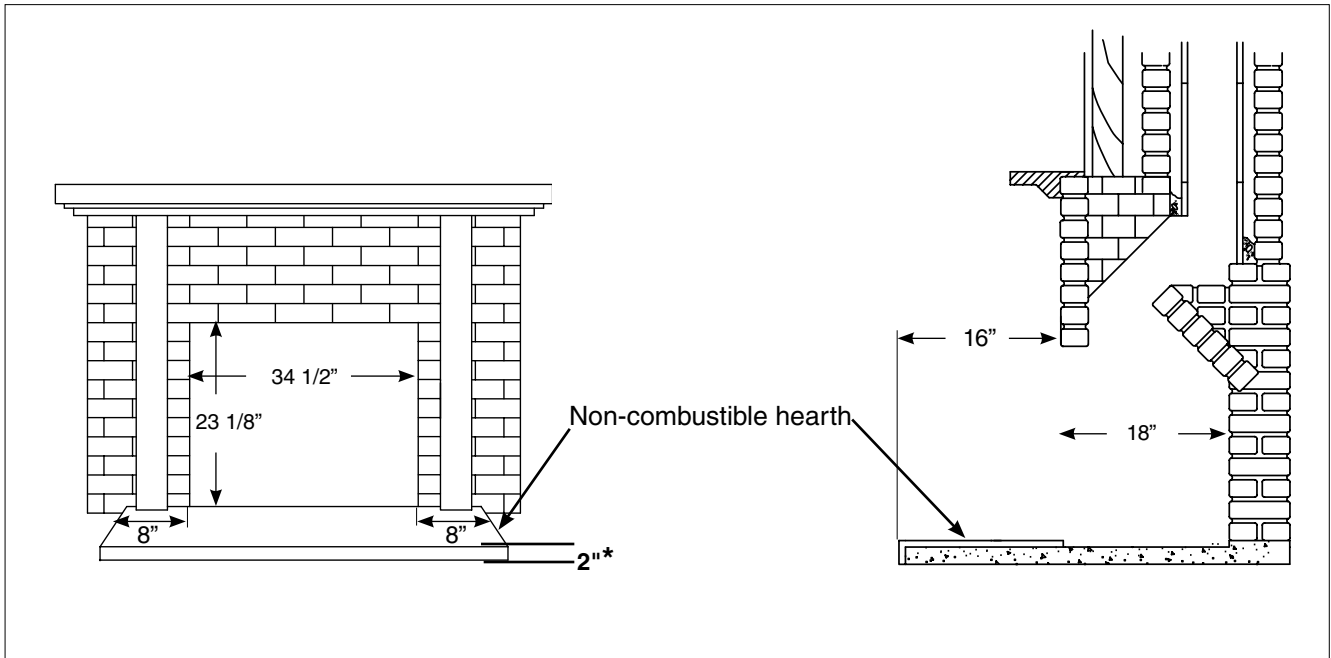

Insert Ember Protection: Combustible floor beyond the hearth must be protected from hot embers by non-combustible material extending 16" to the firing side and 8" to the other sides of the unit

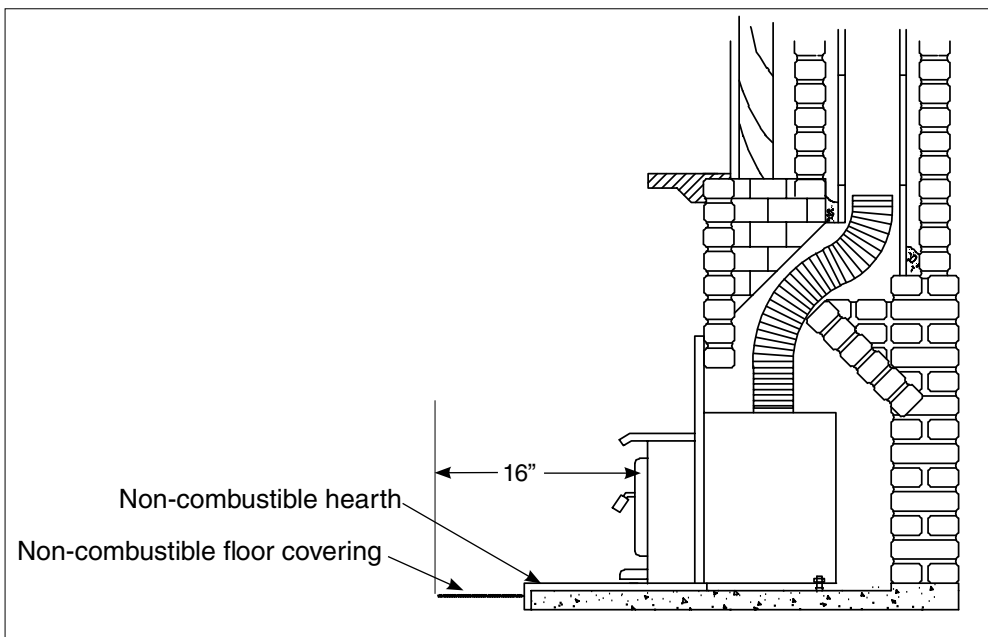

Installation

Your Insert is designed to be installed into a masonry or factory built zero-clearance fireplace. The masonry fireplace must be built according to the requirements of the Standard of Chimneys, Fireplaces, Vents and Solid Fuel Burning appliances, N.F.P.A. 211 (Latest Edition) or applicable National, Provincial, State or local codes. The installation shall conform to CAN/CSA-B365, Installation Code for Solid-Fuel-Burning Appliances and Equipment. The factory built zero-clearance fireplace and its chimney must be listed per UL 127 or ULC S610 standards.

Warning: Under no circumstances is this heater to be installed in a makeshift or "temporary" manner.

DO NOT CONNECT THIS UNIT TO A CHIMNEY FLUE SERVICING ANOTHER APPLIANCE.

Fireplace Specifications

Your fireplace is required to have the following minimum sizes:

WIDTH (at front)	34-1/2" (876 mm)
WIDTH (at rear)	26-1/2" (673 mm)
HEIGHT	23-1/8" (587 mm)
DEPTH	18" (778 mm)

Chimney height 15' (minimum).

A metal tag is provided and is to be fastened to the back wall of the fireplace, if the fireplace has been modified to accommodate the insert.

Into a Masonry Fireplace

Inspect your fireplace for cracks, loose mortar or other physical defects. If repairs are required, they should be completed before installing your insert.

The fireplace chimney must be suitable for wood burning use. Check for creosote build up or other obstructions, especially if it has not been in use for some time.

The existing fireplace damper is to be locked open or removed completely.

WARNING: Do not remove bricks or mortar from your existing fireplace.

Exception: Masonry or steel, including the damper plate, may be removed from the smoke shelf and adjacent damper frame if necessary to accommodate a chimney liner, provided that their removal will not weaken the structure of the fireplace and chimney, and will not reduce protection for combustible materials to less than that required by the National Building Code.

The Insert must be installed in accordance with local and or national building codes. The two methods of flue connection that are acceptable in most areas are:

Fig. # 2

Full Flue Liner

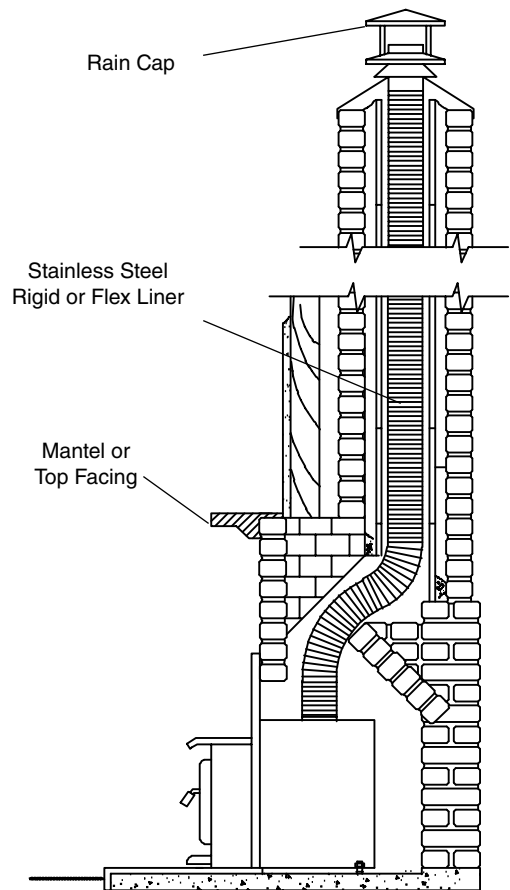

Full Flue Liner: where a listed stainless steel rigid or flexible liner extends from the Insert flue collar to the top of the chimney.

Direct Flue Connection: where a listed stainless steel rigid or flexible liner extends from the Insert flue collar to the first chimney flue liner.

Note: A clean-out door may be required under local codes, when a direct flue connection is used. Consult local codes.

Pacific Energy highly recommends the use of a full liner as the safest installation and providing optimum performance. When connected to a full liner, the Insert is able to draft correctly and will prevent problems such as difficult start-ups and smoking out the door.

Full Flue Liner - (Required in Canada)

- 1) Measure the chimney height from the top of the existing flue to the floor of the hearth. This will allow extra length of liner for flashing and rain cap.
- 2) Feed the stainless steel liner from top of the chimney, through the damper area and into the fireplace cavity.
- 3) Attach a stove connector to the bottom of the liner.
- 4) Push the Insert into position inside the fireplace and attach the connector to the stove collar. Use the rear adjusting legs to level the Insert.

Note: For better access, the top of the casing may be removed (Fig. #4). If it is necessary to get access to the connector pipe through the flue outlet of the Insert, the baffle can be removed (see Baffle Removal section).

- 5) Measure, trim and shape a top flashing to fit the existing chimney flue. Plan for a 1" to 1-1/2" overlap on each side. Place flashing over top of the liner and seat firmly against the tile.
- 6) Screw flashing collar to liner. Caulk gap around flashing with RTV silicone.
- 7) Attach a rain cap to the end of the liner. A storm collar may be used if desired.

Consult your local Dealer about relining your fireplace chimney.

Direct Flue Connection

- 1) Measure from the first chimney flue liner to the top of the Insert. Allow extra length of liner to insert into flue tile.
- 2) Feed the stainless steel liner through the damper area and into the first chimney flue tile. Seal around pipe.

Note: A clean-out door may be required under local codes, when a direct flue connection is used. Consult local codes.

- 3) Push the Insert into position inside the fireplace and attach the connector pipe to the stove collar. Use the rear adjusting legs to level the Insert.

Note: For better access, the top of the casing may be removed (Fig. #4). If it is necessary to get access to the connector pipe through the flue outlet of the Insert, the baffle can be removed (see Baffle Removal section).

Fig. # 4

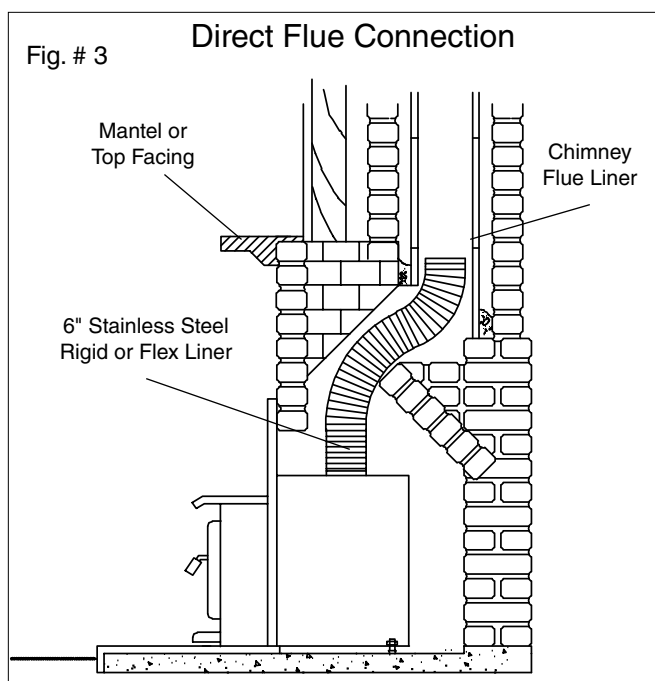

Into a Factory Built Fireplace

Your Insert may be installed into a factory built fireplace (size permitting) with the following requirements:

- 1) Inspect your fireplace for damage or other physical defects. The fireplace must be in good working condition. If in doubt about its condition, seek professional advice. Check for creosote build up or other obstructions inside the chimney, especially if it has not been in use for some time. Before installing, clean your chimney system thoroughly.
- 2) A full stainless steel rigid or flexible flue liner meeting type HT requirements (2100°F) per UL1777 (U.S.) or ULC S635 (Canada) must be used for both safety and performance. The liner must be securely attached to the Insert flue collar and the chimney top.
- 3) The surround must be sealed to the fireplace front or the damper area around the chimney liner must be sealed to prevent room air entering the chimney cavity of the fireplace.
- 4) The air flow within and around the fireplace must not be altered by the installation of the Insert (i.e. no blockage of louvers or cooling air inlet or outlet ports). This includes the circulating air chambers in a steel fireplace or metal heat circulator.
- 5) Alteration of the fireplace in any manner is not permitted with the following exceptions:
 - a: external trim pieces which do not affect the operation of the fireplace may be removed and stored on or within the fireplace for re-assembly if the Insert is removed.
 - b: the chimney damper may be removed to install the liner.

Surround Assembly and Installation

- 1) Lay part A, B and C face down on a flat non-marring surface. Fasten together with 1/4" x 1/2" bolts and nuts provided through holes at points "D" (Fig. #5 and 8).
- 2) Lift the surround assembly to the upright position and make sure the front face is flat and even at the joints.
- 3) Assemble the three trim pieces using the enclosed hardware. Slide part F into the back corners of the trim and tighten screws. Ensure the mitred corners fit tightly and evenly (Fig. #6).
- 4) Slide the assembled trim over the surround from the top (Fig. #5).
- 5) Tighten the retaining screws at the bottom of each trim side (Fig. #7).

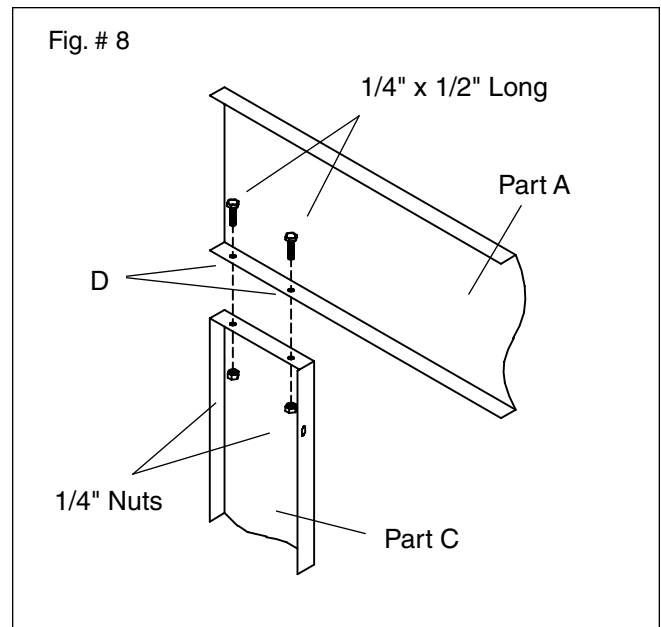
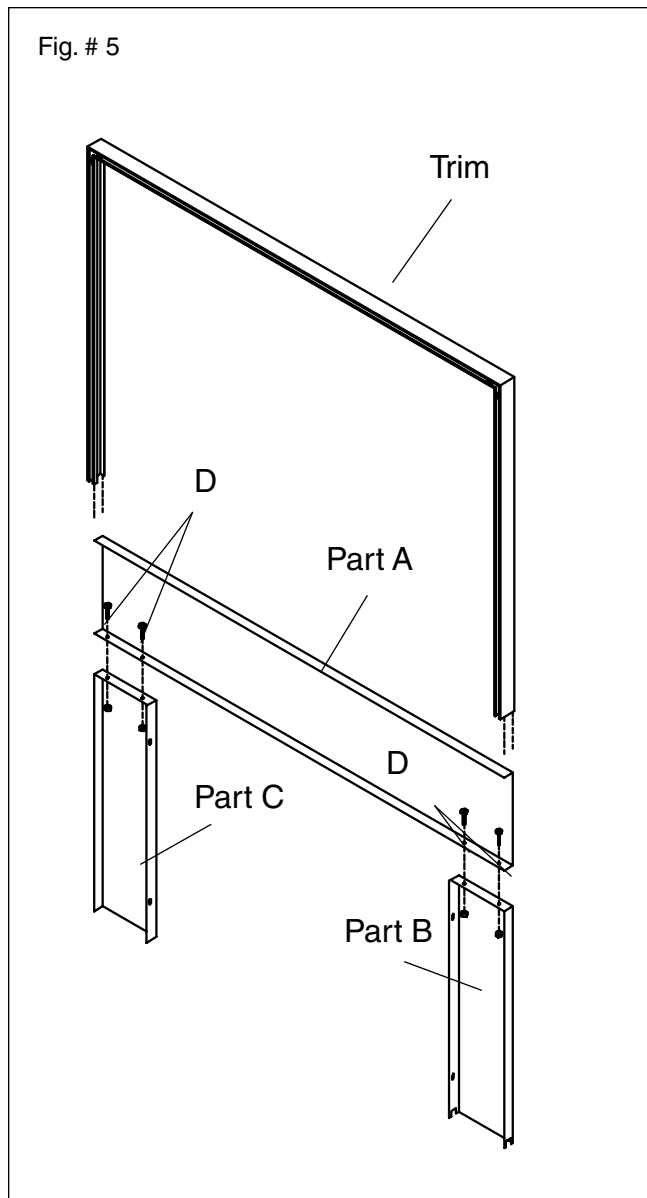
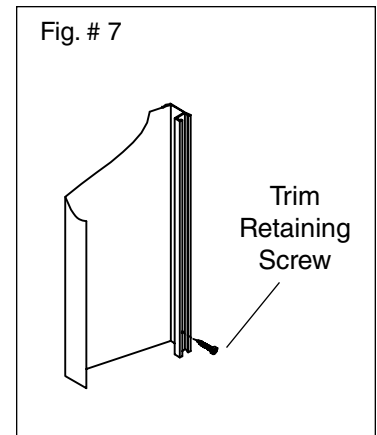
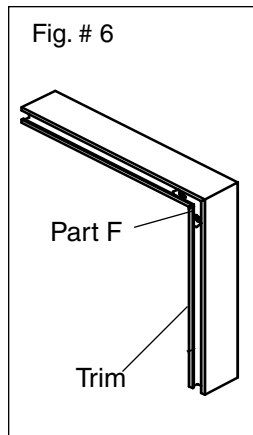

- 6) On the stove, loosen the two bolts that fasten the ashlip in place and remove. Place on a flat, stable surface to avoid damage (Fig. #9).



Fig. # 10



- 7) Remove the two screws which were concealed by the ashlip and two screws near the top from the left and right panels. Remove front panels and set aside to prevent damage.

Fig. # 11



- 8) Slide pre-assembled surround into the friction fit tabs on the inside of the outer casing. **DO NOT LIFT THE SURROUND ASSEMBLY BY GRASPING THE TRIM.** The surround is held in place by four screws, two each side, just inside the casing near the top and bottom. Push surround back until snug and even. Fasten in place.
- 9) Push the entire appliance back until the surround assembly is in contact with the fireplace.

Fig. # 12



- 10) Position the decorative bay stove top onto the firebox top. Ensure that the studs align with the slotted tabs, one on each side of the firebox top. Secure in place with 1/4" nuts provided.
- 11) Replace the front panels and ashlip in the reverse order to their removal.

Fig. # 13

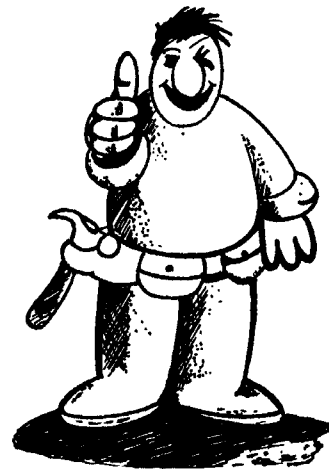

Combustion Air

Consult local building codes regarding combustion air supply. Intake or combustion air can be supplied to the Insert in one of two ways:

- 1) Outside air supply: Remove cover from ash clean out in existing fireplace. Place a rodent screen in place of the cover. Install the Insert as described in the "Installation" section, making sure not to cover the opening of the air inlet. When installation is complete, seal surround to fireplace and anywhere else air may enter. This will ensure combustion air is drawn from outside the house and into the 9" x 2" intake at the lower rear of the appliance.
- 2) Room air supply: Remove the 4" knock-out plug from the casing side prior to installation (Fig. #14). Install the Insert as described in the "Installation" section. The Insert will now draw its air from the room through the front grill.

Fig. # 14



Knock-out Plug

Blower

The Insert comes equipped with a variable speed circulating air blower. The blower system is thermostatically controlled for automatic operation, as well manually with a convenient bypass switch.

Blower Operation

Automatic: To operate the blower automatically, push the rocker switch to the "0" or OFF position and set the fan speed control to a desired setting.

This will allow the blower to turn on automatically once the Insert has come up to operating temperature. It will also shut the blower off after the fire has gone out and the appliance cooled to below a useful heat output range. On and Off times will vary with installation and location of appliance.

Manual: To manually operate the blower, push the rocker switch to the "1" or ON position and set the fan speed control to a desired setting. This will bypass the temperature switch and allow full control of the blower.

Suggested settings:

- Combustion air control setting of "L" (low), operate blower speed control on "Low."
- Combustion air control greater than "L" (low), operate blower speed control at desired setting.

Electrical Supply

Circulating air blower electrical rating; 115V, 60 Hz, 80 Watts. For your protection against shock hazard, use only a properly grounded outlet that will accept a three-pronged plug. Do not cut or remove the grounding prong.

Consult local codes or in the absence of local codes, with the current CSA C22.1 Canadian Electrical Code and in the USA with the National Electrical Code, ANSI/NFPA 70 (latest edition).

Fig. # 15

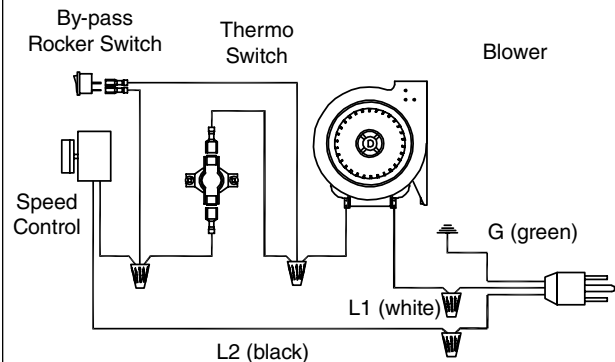

Operation

Wood Selection

This heater is designed to burn natural wood only. Higher efficiency and lower emissions generally result when burning air-dried seasoned hardwoods, as compared to softwoods or too green or freshly cut hardwoods.

Wood should be properly air dried (seasoned) for six months or more. Wet or undried wood will cause the fire to smoulder and produce large amounts of creosote. Wet wood also produces very little heat and tends to go out often.

DO NOT BURN :

- | | |
|--------------------|----------------|
| -Salt water wood * | -Treated wood |
| -Wet or green wood | -Coal/charcoal |
| -Garbage/Plastic * | -Solvents |

* **These materials contain chlorides which will rapidly destroy metal surfaces and void warranty.**

Do not burn anything but wood. Other fuel, e.g. charcoal, can produce large amounts of carbon monoxide, a tasteless, odourless gas that can kill. Under no circumstances should you attempt to barbecue in this heater.

How to Test Your Wood

Add a large piece of wood to the stove when it has a good large bed of coals. It is dry if it is burning on more than one side within one minute. It is damp if it turns black and lights within three minutes. If it sizzles, hisses and blackens without igniting in five minutes it is soaked and should not be burnt.

WARNING: Do not use grates or andirons to elevate the fuel. Burn directly on the firebricks. Replace broken or missing bricks. Failure to do so may create a hazardous condition.

Your Pacific Energy heater is designed for maximum overall efficiency at a moderate firing rate. Overfiring is hazardous and a waste of fuel. Too slow a burn contributes to creosote buildup and lowers combustion efficiency.

Lighting the Fire

WARNING: Never use chemicals or any other volatile liquid to start a fire.

- 1) Adjust air control to "H" (high) position and open door.
- 2) Place crumpled newspaper in the centre of the heater and criss-cross with several pieces of dry kindling. Add a few small pieces of dry wood on top.

- 3) Ignite the paper and close the door.
- 4) After the fire as established itself, open the door and add a few small logs. Close door.
- 5) Begin normal operation after a good coal base exists and wood has charred.

Normal Operation

- 1) Set air control to desired setting. If smoke pours down across the glass (waterfall effect), this indicates you have shut the control down too soon or you are using too low a setting. As every home's heating needs vary (i.e. insulation, windows, climate, etc.), the proper setting can only be found by trial and error and should be noted for future burns.
- 2) To refuel, adjust air control to "H" (high), and give the fire time to brighten. Open door slowly, this will prevent backpuffing.
- 3) Use wood of different shape, diameter and length (up to 19"). Load your wood endwise and try to place the logs so that air can flow between them. Always use dry wood.
- 4) Do not load fuel to a height or in such a manner that would be hazardous when opening the door.
- 5) For extended or overnight burns, unsplit logs are preferred. Remember to char the wood completely on "H" (high) setting before adjusting air control for overnight burn.

WARNING: Always keep loading door closed when burning. This heater is not designed for open door burning.

Restarting After Extended or Overnight Burns

- 1) Open door and rake hot embers towards the front of the heater. Add a couple of dry, split logs on top of embers, close door.
- 2) Adjust air control to "H" (high) and in just a few minutes, logs should begin burning.
- 3) After wood has charred, reset air control to desired setting.
- 4) When burning at a slow rate for extended periods, occasionally maintain a strong fire under supervision for a couple of hours to relieve firebox and chimney deposits as well as any of the deposits on the glass.

WARNING: This method is not a substitute for regular chimney inspections and cleaning.

- 5) To achieve maximum firing rate, set control to "H" (high). Do not use this setting other than for starting or preheating fresh fuel loads.

DO NOT OVERFIRE THIS HEATER: Attempts to achieve heat output rates that exceed heater design specifications can result in permanent damage to the heater and chimney.

WARNING: No alteration or modification of the combustion air control assembly is permitted. Any tampering will void warranty and could be very hazardous.

More Wood, More Heat

Seasoned wood has approximately 7500 BTU's per pound. If you put 10 pounds of wood in your stove for an eight hour burn the wood will be producing 9375 BTU's per hour. (7500 BTU x 10 lbs / 8 hrs. = 9375 BTU's per hr.). If you put 20 lbs of wood in your stove for an eight hour burn you will get 18,750 BTU's per hr. (7500 BTU x 20 lbs / 8 hrs. = 18,750 BTU's per hr.). This is only an example and is based on 100% efficiency. In reality, your stove should perform in the 70% efficiency range.

Experience will give you the right settings for proper combustion and efficient burning. Remember the air inlet setting is affected by variables such as type of wood, outside temperature, chimney size and weather conditions. With practice, you will become proficient in operating your heater and will obtain the performance for which it was designed.

Proper Draft

- 1) Draft is the force which moves air from the appliance up through the chimney. The amount of draft in your chimney depends on the length of the chimney, local geography, nearby obstructions and other factors.
- 2) Too much draft may cause excessive temperatures in the appliance. An uncontrollable burn or a glowing red stove part or chimney indicates excessive draft.
- 3) Inadequate draft may cause backpuffing into the room and plugging of the chimney. Smoke leaking into the room through appliance and chimney connector joints indicates inadequate draft.

Ash Removal

Whenever ashes get 3 to 4 inches deep in your firebox, and when fire has burned down and cooled, remove excess ashes. Leave an ash bed approximately 1 inch deep on the firebox bottom to help maintain a hot charcoal bed.

Disposal of Ashes

Ashes should be placed in a metal container with a tight fitting lid. The closed container of ashes should be placed on a non-combustible floor or on the ground, well away from all combustible materials, pending final disposal. If the ashes are disposed of by burial in soil or otherwise locally dispersed, they should be retained in the closed container until all cinders have thoroughly cooled. Other waste should not be placed in this container!

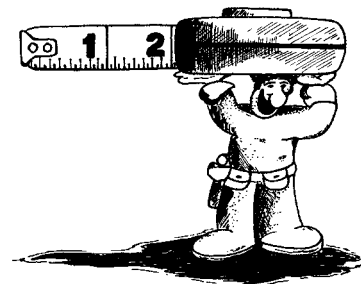

Creosote

Formation and Need for Removal

When wood is burned slowly, it produces tar and other organic vapours, which combine with expelled moisture to form creosote. The creosote vapours condense in the relatively cool chimney flue of a slow burning fire. As a result, creosote residue accumulates on the flue lining. When ignited, this creosote makes an extremely hot fire. The chimney connector and chimney should be inspected at least once every two months during the heating season to determine if a creosote buildup has occurred. If creosote has accumulated, it should be removed to reduce the risk of a chimney fire.

1. Highest smoke densities occur when a large amount of wood is added to a bed of hot coals and the air inlet is closed. The heated wood generates smoke, but without ample air, the smoke cannot burn. Smoke-free, clean burning requires small fuel loads, two or three logs at a time or 1/4 to 1/2 of a fuel load and leaving the air inlet relatively wide open, especially during the first 10 to 30 minutes after each loading, when most of the smoke generating reactions are occurring. After 30 minutes or so, the air inlet can be turned down substantially without excessive smoke generation. Wood coals create very little creosote-producing smoke.
2. The cooler the surface over which wood smoke is passing, the more creosote will be condensed. Wet or green wood contributes significantly to creosote formation as the excess moisture that is boiled off cools the fire, making it difficult for the tars and gasses to ignite, thus creating dense smoke and poor combustion. This moisture-laden smoke cools the chimney, compounding the problem by offering the smoke the ideal place to condense.

In summary, a certain amount of creosote is inevitable and must be lived with. Regular inspection and cleaning is the solution. The use of dry, seasoned wood and ample combustion air will help to minimize the buildup.

Chimney Fires

The result of excessive creosote buildup is a chimney fire. Chimney fires are dangerous. Chimney inside temperatures can exceed 2000 degrees F. This causes much higher than normal temperatures in the chimney and on its exterior surfaces thus ignition of nearby or touching combustible material is more likely during a chimney fire. Proper clearances are critical during such a fire.

Chimney fires are easy to detect; they usually involve one or more of the following:

- Flames and sparks shooting out of the top of the chimney
- A roaring sound
- Vibration of the chimney

In Case of a Chimney Fire

1. Prepare to evacuate to ensure everyone's safety. Have a well understood plan of action for evacuation. Have a place outside where everyone is to meet.
2. Close air inlets on stove.
3. Call local fire department. Have a fire extinguisher handy. Contact your local fire authority for further information on how to handle a chimney fire. It is most important that you have a clearly understood plan on how to handle a chimney fire.
4. After the chimney fire is out, the chimney must be cleaned and checked for stress and cracking before starting another fire. Also check combustibles around chimney and the roof.
 - The services of a competent or certified installer, (certified by the Wood Energy Technical Training program (WETT) - in Canada, Hearth Education Foundation (HEARTH) - in U.S.A.,) are strongly recommended.

Avoiding a Chimney Fire

There are two ways to avoid chimney fires:

1. Do not let creosote build up to a point where a big chimney fire is possible.
2. Do not have fires in the heater that may ignite chimney fires. These are hot fires, such as when burning household trash, cardboard, Christmas tree limbs, or even ordinary fuel wood; (eg. with a full load on a hot bed of coals and with the air inlet wide open).

Maintenance

1. Burn wood only, dry and well seasoned. The denser or heavier the wood when dry, the greater its heat value. This is why hardwoods are generally preferred. Green or wet wood will cause a rapid buildup of creosote. If you feel it is necessary to burn wet or unseasoned wood, do so only with the air inlet set open enough to maintain a good strong fire and fairly high chimney temperatures. Do not attempt to burn overnight using green or wet wood. Wet wood can cause up to 25% drop in heater output, as well as contributing significantly to creosote buildup.

WARNING: Never use chemicals or any other volatile liquid to start a fire. Do not burn garbage, or flammable fluids such as gasoline, naphtha, or engine oil. We strongly recommend that smoke detectors be installed.

2. Remove ashes frequently. Embers can roll out the door and create a fire hazard. Maintain a 1" minimum ash base.
3. If glass becomes darkened through slow burning or poor wood, it can readily be cleaned with any fireplace glass cleaner when stove is cold. Never scrape with an object that might scratch the glass. The type and amount of deposit on the glass is a good indication of flue pipe and chimney buildup. A light brown dusty deposit that is easily wiped off usually indicates good combustion and dry, well-seasoned wood and therefore relatively clean pipes and chimney. On the other hand, a black, greasy deposit that is difficult to remove is a result of wet and green wood and too slow a burning rate. This heavy deposit is building up at least as quickly in the chimney.

WARNING: Only use materials supplied by the manufacturer when doing maintenance or replacements.

4. DOOR GASKET - The gasket used by Pacific Energy requires only light pressure to seal. This will prolong seal life. It is important that the door seal be maintained in good condition. Periodically inspect seals and replace if necessary. Follow instructions included in the DRSM.20832 kit obtainable from your nearest Pacific Energy Dealer.
5. DOOR GLASS - Do not slam loading door or otherwise impact glass. When closing door, make sure that no logs protrude to impact the glass. If the glass gets cracked or broken, it must be replaced before using the stove. Replacement glass can be obtained from your Dealer. The size required is 9-1/8 x 15-5/8 (Pacific Insert) or 9-7/8 x 17-7/8 (Summit Insert) x 5 mm Robax. Ceramic glass must be used. Do not substitute with any other type.

To remove broken glass, undo the four retaining screws and remove the frame noting position for re-assembly. Remove all particles of glass. Be careful as they are very sharp. Install new glass complete with gasket. Replace frame and screws.

WARNING: Do not overtighten, tighten screws very carefully.

- Do not clean glass when hot
 - Do not use abrasive cleaners on glass
6. The area where boost combustion air enters the firebox must be kept clear of excessive ash buildup which will block air flow. This area is at the front of the firebox.
 7. Do not store wood within heater installation clearances, or within the space required for fuel loading and ash removal. Keep the area around the heater clean and free of all loose combustibles, furniture, newspapers, etc.
 8. If gold door requires cleaning, use mild soap and water only. Use of abrasive cleaners will void warranty.
 9. Establish a routine for the fuel, wood burning and firing technique. Check daily for creosote buildup until experience shows how often you need to be cleaning to be safe.
 10. Be aware that the hotter the fire, the less creosote is deposited. Weekly cleaning may be necessary in mild weather, even though monthly cleaning is usually enough in the coldest months when burning rates are higher.
 11. Instruct all members of your family on the safe operation of the heater. Ensure they have enough knowledge of the entire system if they are expected to operate it. Stress the section on chimney fires and the importance of following the steps outlined in "In Case of Chimney Fire".

Baffle Removal

The Insert and pipe should be removed from the fireplace to clean and inspect. Only if this is not possible should you remove baffle assembly.

DO NOT OPERATE WITH BAFFLE ASSEMBLY OR INSULATION REMOVED.

Baffle Assembly Removal

Remove retaining pin at the back top of the firebox, just under the baffle. Lift baffle up and pull forward to disconnect from the supply tube. Tilt baffle sideways to drop down and remove from firebox. Remove insulation to access flue outlet.

Inspect gasket between baffle and supply tube. If necessary, replace with gasket #3139.5 available from your nearest Pacific Energy Dealer.

Re-install baffle assembly and insulation by reversing order.

Appendix A

Troubleshooting

Problem	Cause	Cure
Excessive Creosote Buildup	1) Wood is too wet	- Use dry wood
	2) Turning down air control too soon	- Do not turn down until: a) there is a good bed of coals b) the wood is charred
	3) Draft too low	- Improper chimney height and/or diameter - Chimney plugged or restricted, check flue - Provide outside air for combustion
Glass is Dirty	1) See 1, 2, and 3 above	
	2) Door Gasket leakage	- Replace gasket - Check latch
Low Heat Output	1) Wood is wet	- Use dry wood
	2) Fire too small	- Build a larger fire
Won't Burn Overnight	1) Air control set too high	- Set control lower
	2) Not enough wood	- Unsplit wood is preferred for overnight burns
Stove Won't Burn	1) Combustion air supply is blocked	- Check outside air supply for obstructions (see Combustion Air section)
	2) Draft too low	- Chimney plugged or restricted Inspect and clean - Chimney oversized or otherwise unsuitable Consult Dealer

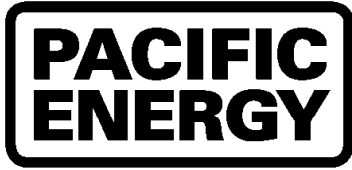

Firebrick Installation Instructions

Pacific Summit Wood Stoves

(Free-standing and insert models)

This package contains 19 full-size firebricks, as well as 5 various cut bricks. If your heater came with an ash cleanout system, or an optional one is being installed, one full-size brick (D) will not be needed for your installation.

With the woodstove in the upright position, install firebricks as follows:

- 1) Place the firebricks on the bottom of the unit first. If stove is equipped with an ash cleanout system use a total of 8 full-size (D) and 3 cut bricks (A, B, C). If no ash cleanout system is installed use 9 full-size (D) and 1 cut bricks (C).
- 2) Next install 4 full-size firebricks against the rear wall as shown.
- 3) Finally install the side firebricks, 3 full-size bricks and one cut brick (E) on each side of the firebox as shown.

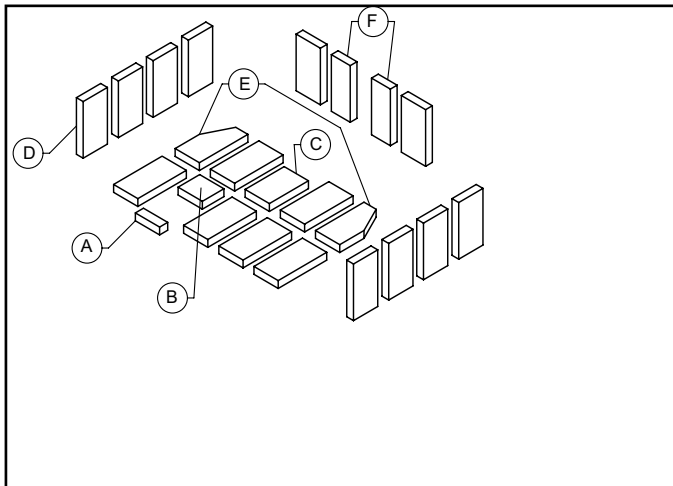

With Ash Cleanout System Installed

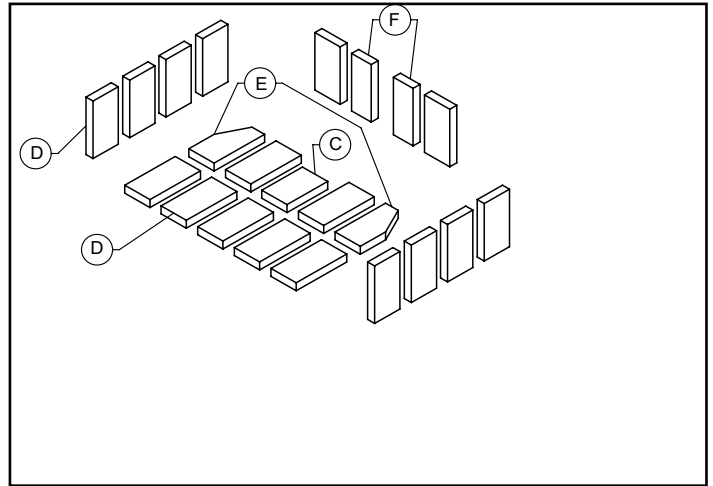

Without Ash Cleanout System Installed (And Insert)

ITEM	SIZE		PART NUMBER
A	1 1/2" X 4 1/2" X 1 1/4"	(39 mm x 115 mm x 32 mm)	248.0
B	4" X 4 1/2" X 1 1/4"	(102 mm x 115 mm x 32 mm)	246.0
C	7 1/4" X 4 1/2" X 1 1/4"	(184 mm x 115 mm x 32 mm)	245.0
D	9" X 4 1/2" X 1 1/4"	(230 mm x 115 mm x 32 mm)	5096.99
E	9" X 3 1/2" X 1 1/4"	(102 mm x 115 mm x 32 mm)	3245.5

Replacement Parts

(WHEN ORDERING, INCLUDE PART NUMBER WITH DESCRIPTION)

ITEM	DESCRIPTION	PART NO.	ITEM	DESCRIPTION	PART NO.
3.....	Bay Top (c/w Washers and Nuts).....	SINS.3535			
4.....	Casing Top, Back	3502		Door Casting Arched Nickel.....	CAST.46NIA
5.....	Casing Top, Front.....	3502.51		Door Casting Arched Brushed Nickel.....	CAST.46BNA
6.....	Casing Back.....	3504.001	32....	Door Handle Assembly (c/w Wood Handle and Nut)	WODC.4147C
7a....	Air Deflector, Center	3506			
7b....	Air Deflector, Right.....	3506.5	33....	Baffle Pin	125
10....	Front Panel, Left	SINS.3509.01	34....	Brick Rail Set(2 pcs. required)	SUMM.RAILSET
11....	Casing Side, Left	SINS.3509.51	36....	Baffle.....	SUMM.BAFKIT
12....	Panel Standoff (2 pcs. required).....	510.1	38....	Flame Shield (c/w Bolt, Washer and Nut).....	SINS.35135
13....	Blower Standoff	510	39....	Boost Manifold.....	3105.111
14....	Door Catch (c/w Bolt)	WODC.1461	40....	Firebrick - 9" x 4 1/2" x 1 1/4" (19 pcs. required).....	5096.99
15....	Ash Lip (c/w Gold Trim).....	ALIP.503747MB	41....	Firebrick - 7 1/4" x 4 1/2" x 1 1/4" (1 pcs. required).....	245
16....	Quadrant Shield.....	3536.01	42....	Firebrick - 9" x 3 1/2" x 1 1/4" (2 pcs. required).....	3245.5
17....	Panel Standoff Spacer.....	510.2		Firebrick Set.....	BRIC.SUMMA
18....	Casing Bottom	3501	43....	Replacement Blower Assembly (c/w Cord, Switch)	SINS.4532ASY
19....	Casing Side, Right.....	3503.5		Blower Only	5024.6
20....	Front Panel, Right.....	SINS.3509.5		Standard-Size Surround Assembly, Embossed Panels	
23....	EBT Gasket	5068.3237101	48	3/4" wide x 32" high	
24....	EBT (c/w Gasket #3237 and Rivets).....	SUMM.EBT.B		Over-Size Surround Assembly, Plain Panels	
25....	Quadrant Cover	3514		52 3/4" wide x 34" high	
26....	Air Shutter Assembly (c/w Spring, Washer and Cap).....	SUMM.531			
27....	Glass Clamp Kit (c/w Screws)	SUMM.1425			
28....	Glass Bar Kit (2 pcs.).....	SUMM.312501			
	Glass Gasket Kit (not shown).....	DR46.GLKIT			
29....	Rep. Glass (c/w Glass Gasket).....	2083.01			
30....	Door Gasket Kit	DR46.DGKIT			
31....	Door Casting, Arched Black.....	CAST.46ST			
	Door Casting, Arched Gold.....	CAST.46GDA			

All parts may be ordered from your nearest Pacific Energy dealer. Contact Pacific Energy for the location of the dealer nearest you.

Fig. # 18

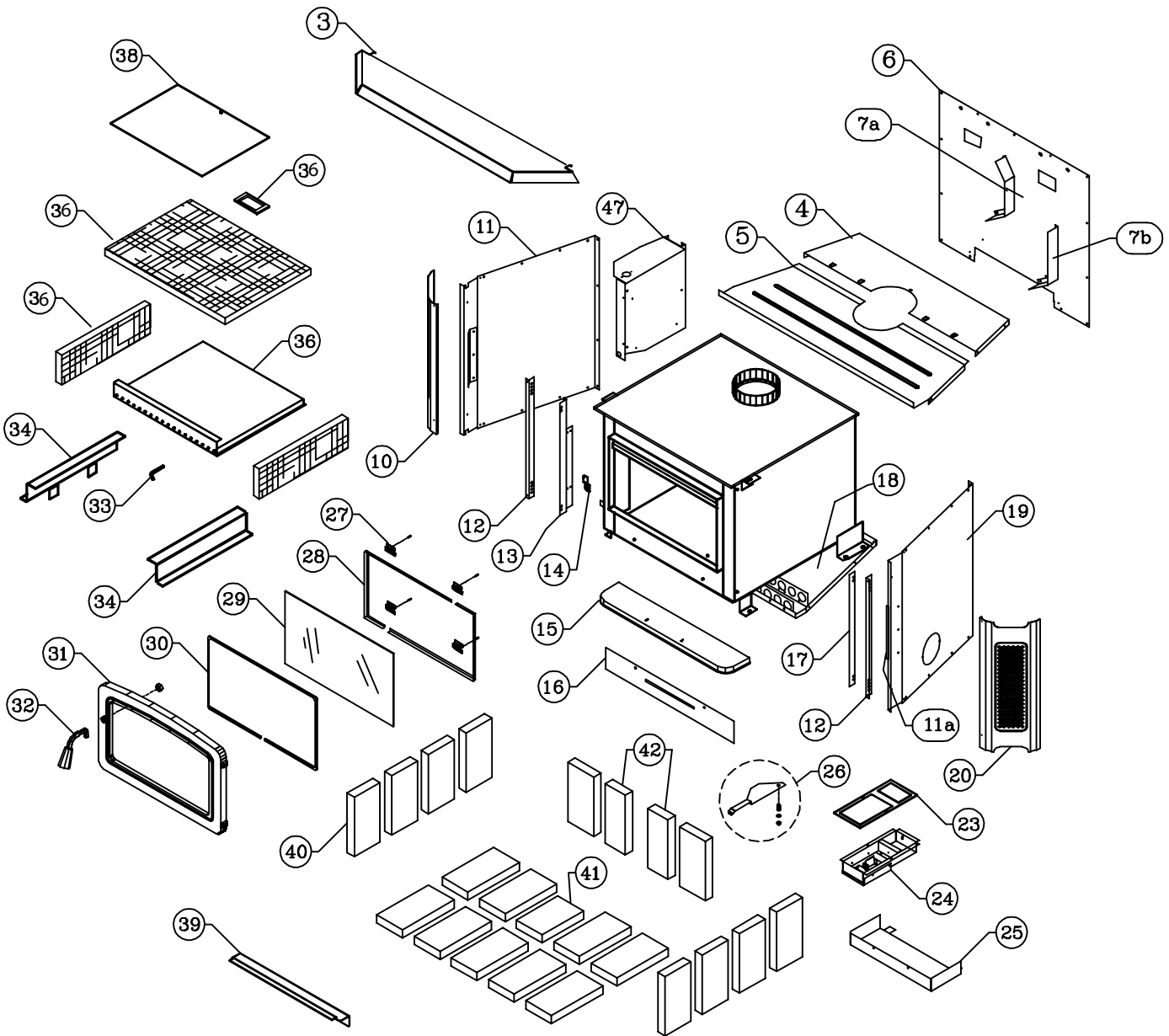

Understanding & Operating Your Pacific Energy Stove

The Pacific Energy line of wood stoves is a culmination of years of research and development. Designed to be efficient, clean-burning and user-friendly, this heater will give you years of warm service. However, a knowledgeable operator is still the most important factor for maximum performance and part of this is understanding the basic functions of this design.

Traditional wood stoves had a basic combustion system which allowed a considerable amount of heat energy to escape up the chimney as unburned gases and particulates (smoke). Pacific Energy has designed a system that solves the problem by burning the smoke and releasing the additional heat to the room.

This system has two critical design features:

1. Above fire secondary air injection:
The hollow "air baffle" injects superheated secondary air just above the load. With the stove at the proper operating temperature, this will create a secondary flame that will be evident for approximately 1/3 of the total burn time.

2. High mass and thermal insulation:
The high mass (weight) acts as a heat storage and the thermal insulation keeps the combustion zone hot.

Active flaming takes place during the first part of the burn. During this storage, heat is stored in the mass of the unit and is later released slowly and evenly. As wood chars, active flaming will diminish. This clean charcoal burning stage will last for a considerable length of time and refuelling should be avoided until the charcoal base has become quite small.

OPERATING TIPS

1. Always use dry, seasoned firewood, up to 18" long. Load wood endwise, a mixture of large and small pieces, on top of a good ash base (1" minimum).

2. Operate on a medium to high setting, for up to 1 hour from cold start. After the initial warm up period, refuel and leave the air control on a medium setting for 5 to 10 minutes more and then set the air control to the desired position.

3. If a slow burn is desired, set the air control to low. Active secondary burning should be present above the wood load. If it is not present or goes out shortly after, proper

operating temperature has not been reached and the stove needs additional warm up time.

For additional operating, safety and maintenance information refer to the installation manual.

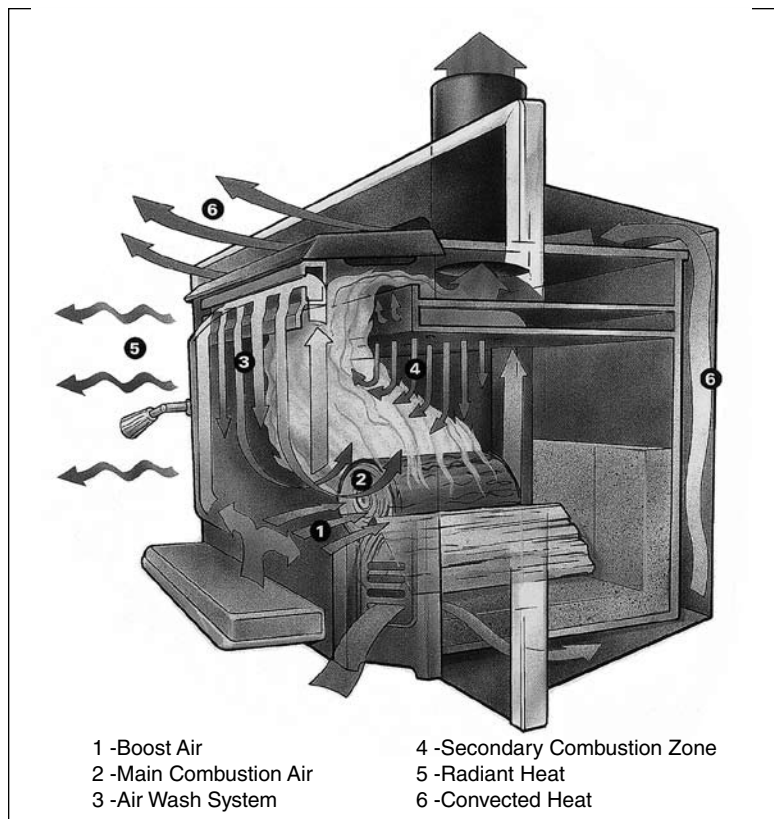



US

LISTED FACTORY BUILT FIREPLACE ACCESSORY INSERT
CERTIFIED FOR USE IN CANADA AND U.S.A.

MODEL: PACIFIC SUMMIT INSERT SERIES: A

TESTED TO: ULCS628 / UL1482 REPORT NO: 476-1711-00 (OCT 1999)

WH- A

• INSTALL AND USE ONLY IN ACCORDANCE WITH THE MANUFACTURER'S INSTALLATION AND OPERATING INSTRUCTIONS. CONTACT LOCAL BUILDING OR FIRE OFFICIALS ABOUT RESTRICTIONS, INSTALLATION PERMIT AND INSPECTION IN YOUR AREA.

MINIMUM CLEARANCE TO COMBUSTIBLES (MEASURED FROM INSERT BODY)	
A) ADJACENT SIDEWALL	216 mm / 8.5 in.
B) MANTLE	533 mm / 21 in.
C) TOP FACING	533 mm / 21 in.
D) SIDE FACING	216 mm / 8.5 in.



ADJACENT SIDE WALL

CLEARANCE TO COMBUSTIBLE CONSTRUCTION

- INSTALL AND USE ONLY IN MASONRY OR FACTORY BUILT FIREPLACE.
- INSTALL ONLY ON A NON-COMBUSTIBLE HEARTH RAISED 50 MM / 2 IN ABOVE AN ADJACENT COMBUSTIBLE FLOOR. COMBUSTIBLE FLOOR BEYOND HEARTH MUST BE PROTECTED BY NON-COMBUSTIBLE FLOOR MATERIAL EXTENDING 405 mm / 16 in. TO THE FIRING SIDE (E) AND 200 mm / 8 in. TO THE OTHER SIDES (F) OF THE UNIT.
- DO NOT REMOVE BRICKS OR MORTAR FROM MASONRY FIREPLACE
- DO NOT CONNECT THIS UNIT TO A CHIMNEY SERVING ANOTHER APPLIANCE
- COMPONENTS REQUIRED FOR INSTALLATION: FULL FLUE LINER OR DIRECT FLUE CONNECTION ASSEMBLY.
- OPTIONAL COMPONENTS: FAN KIT, ELECTRICAL RATING 115V, 60HZ, 1 AMP.
- DANGER: RISK OF ELECTRICAL SHOCK. DISCONNECT POWER BEFORE SERVICING UNIT.
- ROUTE CORD AWAY FROM UNIT.
- FOR USE WITH SOLID WOOD FUEL ONLY. DO NOT USE GRATE OR ELEVATE FIRE. BUILD WOOD FIRE DIRECTLY ON HEARTH.
- OPERATE WITH FEED DOOR CLOSED. OPEN TO FEED FIRE ONLY.
- REPLACE GLASS ONLY WITH CERAMIC GLASS.
- INSPECT AND CLEAN CHIMNEY FREQUENTLY. UNDER CERTAIN CONDITIONS OF USE, CREOSOTE BUILDUP MAY OCCUR RAPIDLY.



CAUTION

HOT WHILE IN OPERATION. DO NOT TOUCH. KEEP CHILDREN, CLOTHING AND FURNITURE AWAY. CONTACT MAY CAUSE SKIN BURNS. SEE NAMEPLATE AND INSTRUCTIONS.



MANUFACTURED BY:
PACIFIC ENERGY FIREPLACE PRODUCTS LTD.
P.O. BOX 1060, DUNCAN, BC V9L 3Y2

U.S. ENVIRONMENTAL PROTECTION AGENCY
CERTIFIED TO COMPLY WITH JULY, 1990
PARTICULATE EMISSION STANDARDS

DATE OF MANUFACTURE

J	F	M	A	M	J	J	A	S	O	N	D
2009		2010		2011		2012		2013		2014	

MADE IN CANADA

160309
5050.762
SINS-1



PACIFIC ENERGY FIREPLACE PRODUCTS LTD.

Technical Support: 1 887 715-2398

www.pacificenergy.net

2975 Allenby Rd., Duncan, B.C. V9L 6V8

Printed in Canada