

# Installation & Operating Manual

**NOTICE: SAVE THESE INSTRUCTIONS**

# HARMAN®

**BUILT TO A STANDARD, NOT A PRICE**

**Model(s):**

**P61A Freestanding Pellet Stove**

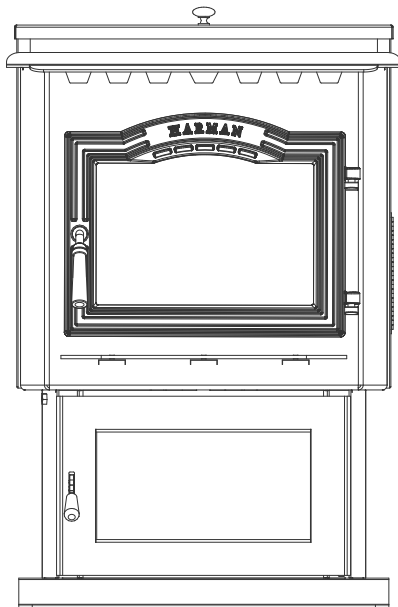

Service parts list has been removed from this manual.  
Refer to Owner's Manual or Individual service parts list.



## WARNING



### HOT SURFACES!

Glass and other surfaces are hot during operation and cool down.

**Hot glass will cause burns.**

- Do not touch glass until it is cooled
- NEVER allow children to touch glass
- Keep children away
- CAREFULLY SUPERVISE children in same room as stove.
- Alert children and adults to hazards of high temperatures.

**High temperatures may ignite clothing or other flammable materials.**

- Keep clothing, furniture, draperies and other flammable materials away.

## NOTE

To obtain a French translation of this manual, please contact your dealer or visit [www.harmanstoves.com](http://www.harmanstoves.com)

Pour obtenir une traduction française de ce manuel, s'il vous plaît contacter votre revendeur ou visitez [www.harmanstoves.com](http://www.harmanstoves.com)

Contact your local dealer with questions on installation, operation or service.

## SAFETY NOTICE

**PLEASE READ THIS ENTIRE MANUAL BEFORE YOU INSTALL AND USE YOUR NEW ROOM HEATER. FAILURE TO FOLLOW INSTRUCTIONS MAY RESULT IN PROPERTY DAMAGE, BODILY INJURY, OR EVEN DEATH.**

**FOR USE IN THE U.S. AND CANADA. SUITABLE FOR INSTALLATION IN MOBILE HOMES.**

**IF THIS HARMAN STOVE IS NOT PROPERLY INSTALLED, A HOUSE FIRE MAY RESULT. FOR YOUR SAFETY, FOLLOW INSTALLATION DIRECTIONS. DO NOT USE MAKESHIFT COMPROMISES.**

**CONTACT LOCAL BUILDING OR FIRE OFFICIALS ABOUT RESTRICTIONS AND INSTALLATION INSPECTION REQUIREMENTS IN YOUR AREA.**

**CONTACT YOUR LOCAL AUTHORITY (SUCH AS MUNICIPAL BUILDING DEPARTMENT, FIRE DEPARTMENT, FIRE PREVENTION BUREAU, ETC.) TO DETERMINE THE NEED FOR A PERMIT.**

**CETTE GUIDE D'UTILISATION EST DISPONIBLE EN FRANCAIS. CHEZ VOTRE CONCESSIONNAIRE DE HARMAN®.**

**SAVE THESE INSTRUCTIONS.**

Please copy your serial number from the label on your stove to the box below.

SERIAL NUMBER



**HARMAN**  
Made in U.S.A. of U.S. and imported parts. / Fabriqué aux États-Unis d'Amérique par des pièces d'origine américaine et pièces importées.

**MODEL / Modèle: "P61A"**  
Room Heater Pellet Fuel Burning Type, Suitable for Mobile-Home Installation.  
Appareil de chauffage à granulés de bois Conçu pour maisons mobiles

**Serial No.**  
**N° de série:** 008

**BARCODE LABEL**



Report # / Rapport # 135-S-22-4, 135-S-22b-6.2  
Tested to / Testé à: ASTM E 1509-04, ULCCORD-C1482-M1900,  
ULC-S627-00

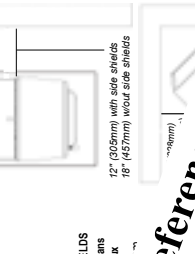

**MINIMUM CLEARANCES TO COMBUSTIBLES /**  
**ÉCARTS MINIMUMS DE SÉCURITÉ PAR RAPPORT AUX**  
**COMBUSTIBLES**

WITHOUT SIDE SHIELDS / Sans Écrans Latéraux	WITH SIDE SHIELDS / Avec Écrans Latéraux
200mm	200mm
450mm	450mm

**PREVENT HOUSE FIRES\***  
Install and Use Only in Accordance With Manufacturer's Instructions, Contact Local Building or Fire Officials About Restrictions and In-

**WARNING: THE STRUCTURAL INTEGRITY OF THE MANU- AND CEILING/ROOF MUST BE MAINTAINED. DO NOT INS-**

An outside combustion air inlet must be provided. Combustion to Manufacturer's instructions and local codes regarding the requirements venting system through a combustible wall or ceiling.

Inspect and Clean Exhaust Venting System Frequently.  
Use a 3" or 4" diameter Type "L" or "PL" venting system.

Do Not Connect This Unit to a Chimney Flue Serving Another Appliance.  
**FOR USE WITH WOOD PELLET FUEL OR UP TO 50% CORN/ PELLET MIXTURE ONLY.**  
The Use of Other Fuels May Create an Unsafe Condition.  
Input Rating Max: 5.5 lb. fuel/hr.

U.S. Electrical Rating: 115 VAC, 60 Hz, Start 4.2 AMPS, Run 2.8 AMPS  
Route Power Cord Away From Unit.

**DANGER:** Risk of Electrical Shock. Disconnect Power Before Servicing Unit.  
For Further Instruction, Refer To Owner's Manual.

Replace glass only with 5mm ceramic available from your dealer.  
Keep Viewing and Ash Removal Doors Tightly Closed During Operation.

**DO NOT REMOVE THIS LABEL / NE PAS ENLEVER CETTE ÉTIQUETTE**

**PREVENTION DES INCENDIES\***  
Respecter scrupuleusement les instructions du constructeur pour l'installation et les consignes de fonctionnement. Respecter les règles de sécurité en vigueur dans votre région.

**AVERTISSEMENT POUR MOBILE HOMES:** Ne pas installer dans une chambre. Il est impératif de prévoir une prise d'air extérieur. L'ingénierie structurelle du plancher, du plafond et des murs doit être strictement préservée. Se reporter aux instructions du fabricant et aux réglementations spécifiques locales concernant les précautions requises lors de la traversée d'un mur ou d'un plafond. Contrôler et nettoyer fréquemment tout le système d'évacuation des fumées conformément aux recommandations du constructeur. Utiliser des tuyaux «Spécial granulés» de 076 mm ou 102 mm. Ne pas raccorder ce poêle à un conduit de cheminée déjà utilisé pour un autre appareil.

**FONCTIONNE EXCLUSIVEMENT AVEC DES GRANULES DE BOIS.**  
Appareil de chauffage à granulés type. Consommation maximum: 3,63 kg/h.

US coupeure: 115 VAC, 60 Hz, 4,2 ampes Démarreur, Exécuter 2,8 AMPS

Tenir le cordon d'alimentation à l'écart du poêle.

**DANGER:** Risque d'électrocution. Débrancher l'appareil avant toute intervention. Ne remplacer la vitre qu'avec une vitre céramique 5mm de même qualité disponible auprès de votre revendeur.

Pour une information plus complète, se reporter à la notice d'utilisation. Tenir la porte hermétiquement close durant fonctionnement.

Ne faites pas obstacle l'espace sous le rechauffeur. Toujours fournir un approvisionnement suffisant en air frais jusqu'au lieu d'installation Appliances

**ENTIRE THIS INFORMATION REGARDING TESTING AND CLEARANCES, CONSULT THE ACTUAL LABEL ON THE REAR OF THE STOVE.**

Entire this information regarding testing and clearances, consult the actual label on the rear of the stove.

**USA**  
FLOOR PROTECTION / Protection: 200mm  
Back\*/Arrière (B) 6" 200mm  
Front/Avant (C) 6" 450mm

\*Measured from pedestal base in the US ONLY  
\*Mesuré à partir de la base du socle aux États-Unis uniquement

\*Measured from Glass Opening  
\*Mesurer à partir de la surface de la porte en verre

Floor Protection Must Be a Non-Combustible Material.  
Must Also be Placed Under Any Horizontal Flue Connector.  
Extending 2" or 5mm Beyond the Pipe Measurement.  
Pour protéger le plancher, il faut sous le poêle un matériau. Qui doit aussi être placé sous les parties horizontales du tuyau de raccord à la cheminée et s'étendre à 51mm ou 2 po. au-delà de la mesure du tuyau.

**ENVIRONMENTAL PROTECTION AGENCY**  
This appliance complies with Canadian Standards Association (CSA) B415.1 and Title 40 of the U.S. Code of Federal Regulations, Part 60, Subpart AAA. This model is exempt from certification under 40 CFR 60.531 by definition [Wood Heater (A) "air-to-fuel ratio"]

\*Conforme à l'Association Canadienne des Standards (CSA) B415.1-10, les Règlements Fédéraux des États-Unis, partie 60, section certification EPA sous 40 CFR 60.531 par définition o Air-Combustible.

**facture / Date de fabrication:**  
APR MAY JUN JUL AUG SEP OCT NOV DEC

Fabrique par: Harth a.s. Technologies 532 Mountain House Road, Halifax PA 17032

P. N. 3-90-08626

2013

Rev E

# Table of Contents

Safety Information	5
Assembly & Installation	5
Venting	7
ESP Control	14
Automatic Operation	15
Manual Operation	18
Low Draft Voltage Adjustment	20
Maintenance	21
Troubleshooting	26
Fuel Specifications	27
Mixing Corn with Pellets	28
Power Failure / Back-up	29
Wiring Diagram	30
Specifications	30
Warranty	31



**HARMAN**<sup>®</sup>  
BUILT TO A STANDARD, NOT A PRICE

Division of Hearth & Home Technologies  
352 Mountain House Road  
Halifax, PA 17032

Listed by: **OMNI**-Test Laboratories, Inc.  
Report #: 135-S-22-4, 135-S-22b-6.2  
Meets requirements of: ASTM E 1509-04, ULC/ORD-C1482-M1990, ULC-S627-00  
This appliance is also approved for installation into a shop.

➔ = Contains updated information

# Safety Information

**DO NOT INSTALL A FLUE DAMPER IN THE EXHAUST VENTING SYSTEM OF THIS UNIT.**

**DO NOT CONNECT THIS UNIT TO A CHIMNEY FLUE SERVING ANOTHER APPLIANCE.**

## **SPECIAL NOTE:**

**DUE TO FLY ASH BUILDUP, IT IS STRONGLY RECOMMENDED THAT YOU HAVE YOUR STOVE PROFESSIONALLY CLEANED AND SERVICED ANNUALLY. THIS INCLUDES ALL PARTS OF THE STOVE, AND THE ENTIRE VENTING SYSTEM.**

## **CAUTION**

**ALWAYS BE SURE THERE IS NO UNBURNED FUEL IN THE ASH PAN PRIOR TO LIGHTING A FIRE. THIS WILL CAUSE SMOKE AND SOOT AND OTHER UNWANTED RESULTS.**

## **CAUTION**

**DO NOT USE MAKESHIFT COMPONENTS OR OTHER COMPROMISES WHEN INSTALLING THIS APPLIANCE.**

**INSTALLATION AND REPAIR OF THIS HARMAN STOVE SHOULD BE DONE BY A QUALIFIED SERVICE PERSON. WE RECOMMEND THAT THE STOVE BE INSPECTED BEFORE USE AND AT LEAST ANNUALLY BY A QUALIFIED SERVICE PERSON. PERIODIC CLEANING IS REQUIRED THROUGHOUT THE HEATING SEASON AND AT THE END OF EACH WINTER FOR THE STOVE TO WORK EFFICIENTLY. REFER TO THE MAINTENANCE SECTION OF THIS MANUAL.**

## **WARNING**

**MOBILE/MANUFACTURED HOME STANDARDS DO NOT ALLOW INSTALLATION IN ROOMS DESIGNATED FOR SLEEPING.**

## **CAUTION**

**THE STRUCTURAL INTEGRITY OF THE MOBILE HOME FLOOR, WALL, AND CEILING/ROOF MUST BE MAINTAINED.**

**MOBILE HOME INSTALLATION SHOULD BE DONE IN ACCORDANCE WITH THE MANUFACTURED HOME AND SAFETY STANDARD (HUD), CFR 3280, PART 24.**

## **CAUTION**

**KEEP COMBUSTIBLE MATERIALS (SUCH AS GRASS, LEAVES, ETC.) AT LEAST 3 FEET AWAY FROM THE FLUE OUTLET ON THE OUTSIDE OF THE BUILDING.**

## **CAUTION**

**A CHIMNEY CONNECTOR SHALL NOT PASS THROUGH AN ATTIC OR ROOF SPACE, CLOSET OR OTHER CONCEALED SPACE, A FLOOR, OR A CEILING.**

## **CAUTION**

**DO NOT CONNECT TO ANY AIR DISTRIBUTION DUCT OR SYSTEM.**

# Assembly and Installation

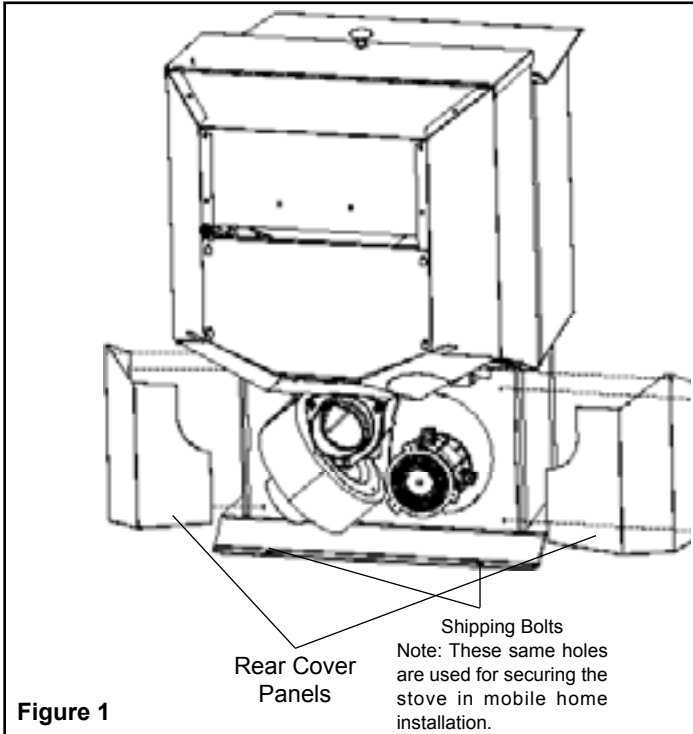

## Room Sensor Installation

The room sensor is a small temperature sensor on the end of a 60" wire. This sensor is installed much like a standard wall thermostat. There is a remote room sensor port on the rear of the unit for easy external connection. Use standard 18-2 thermostat wire to extend the distance to the desired location (50' maximum). The room sensor should be installed in the location where you want to control the temperature.

NOTE: Distances of more than 25 feet from the unit or in another room are not recommended. The room sensor is essential for the P61A's excellent efficiency.

NOTE: **It is recommended that the room sensor be installed**, even if only installed on the rear of the unit as a return air sensor.

## Unpacking

The P61A is bolted (1/4 x 1" hex head bolts) to the skid to prevent movement during shipping.

To free the stove from the skid you must remove the hold-down bolts in the rear of the pedestal base.

## Removing rear cover panels

The rear cover panels are secured to the stove with three bolts each. Two of the bolts need only be loosened, not removed, to remove the panels. It is recommended that the rear covers are installed after the unit is in place and the vent pipe is installed, to prevent contact with hot or moving parts.

## Firebrick

Install the three firebricks vertically on the angle bracket above the burnpot.

## Flame Guide

Install the cast iron flame guide on top of the burn pot. Make sure that the flame guide is fully seated on the vertical sides of the burn pot and that the back of the guide rests against the body of the stove.

**INSTALL EXHAUST VENT AT CLEARANCES SPECIFIED BY THE MANUFACTURER.** Most pellet vent pipe requires a minimum of 1" of clearance to combustible materials although some can be installed at 1" clearance.

Follow these instructions along with all local codes regarding installation of this appliance.

Do **NOT** use makeshift compromises when installing this appliance, serious consequences may result.

With any hearth appliance, installation of smoke detectors is recommended on every level of the home.

## Possible causes of smoke detector activation:

Paint curing process - Open a window near the appliance for the first few hours of burning.

Exhaust being drawn back inside the dwelling - Outside air connection to the appliance is necessary.

Vent leakage - All interior seams and joints should be sealed with silicone where applicable. Follow vent manufacturers instructions for proper sealing.

# Installation

## Installing

Place the stove on a noncombustible floor or on a floor protector that extends a minimum of 6 inches to the front, (measured from the glass) 6 inches to the sides and 6 inches to the rear of the pedestal. It is also recommended that floor protection be installed under any horizontal venting and extending 2 inches beyond the vent measurement.

**NOTE for Canadian installation only:** Per ULC-S627-00, If installed on a combustible floor, the need to provide a noncombustible *floor protector* covering the area beneath the *space heater* and extending at least 17.72" (450mm) on the firing side and at least 7.87" (200mm) on the other sides.

**In Canada, you may follow smaller U.S. floor protection requirements ONLY if the user agrees to completely shut-down the appliance, and allow it to cool to where all fire is extinguished and the combustion blower and its indicator light shuts off, prior to opening the firebox door or ash door.**

Place the stove away from combustible walls at least as far as shown in Figures 3 and 4. Note the difference in side wall clearance with and without side shields.

Note that the clearances shown are minimum for safety but do not leave much room for access when cleaning or servicing.

Connect the power cord to a 120 V.A.C. 60Hz grounded receptacle. (A surge protector is recommended to protect the circuit board.) Also be sure that the polarity of the outlet that the stove is plugged into is correct.

Prior to installing the flue pipe, connect a draft meter. (The draft meter must have a minimum range of 0-.5.) Record the first reading. Connect flue pipe to stove and be sure all doors and windows in the home are closed. Record the second draft reading \_\_\_\_\_. If the second reading is more than .05" lower than the first reading, check for possible restrictions or the need for outside air (see page 9). For more information on the draft test procedure, refer to Page 20.

## Mobile Home Installation

When installing this unit in a mobile home, several requirements must be followed:

1. The unit must be bolted to the floor. This can be done with 1/4" lag screws through the 2 holes in the base plate.
2. The unit must also be connected to outside air. See page 9.
3. Floor protection and clearances must be followed as shown.
4. Unit must be grounded to the metal frame of the mobile home.

**CAUTION: This appliance must be vented to the outside.**

**⚠ WARNING**

**THE STRUCTURAL INTEGRITY OF THE MANUFACTURED HOME FLOOR, WALL, AND CEILING/ROOF MUST BE MAINTAINED.**

---

**DO NOT INSTALL IN SLEEPING ROOM.**

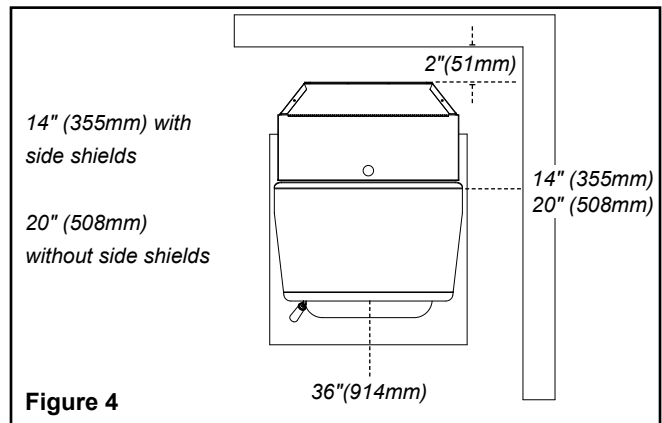
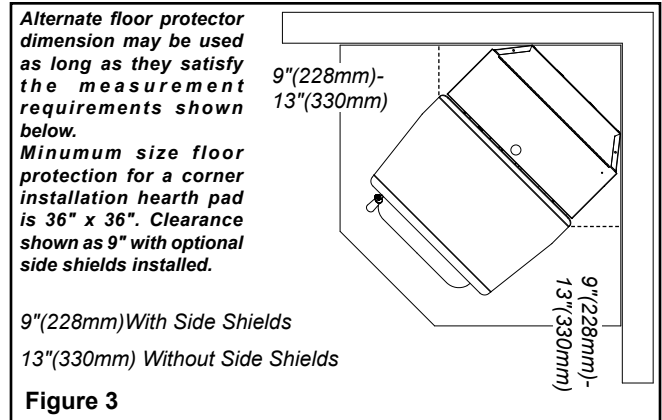

Minimum size rectangular floor protection (USA) is 28<sup>5/16"</sup> Deep By 24<sup>3/4"</sup> Wide.

\* Floor protection dimensions for the front and sides are measured from the appliance door opening in The United States. In Canada, the side dimension is measured from the widest part of the appliance.

Floor Protection Requirements		US	Canada
<b>J</b>	Sides	6"	200mm
<b>K</b>	Front	6"	450mm
<b>L</b>	Rear	6"	200mm

**NOTE:** Measurement "L" is measured from the pedestal base in the US ONLY

**NOTE:** Measurement "K" is measured from the glass in the US ONLY

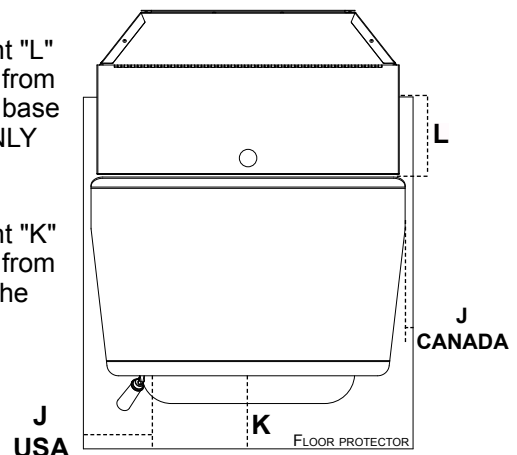

# Venting

## Requirements for Terminating the Venting

**WARNING:** Venting terminals must not be recessed into a wall or siding.

**NOTE:** Only approved pellet vent pipe, wall pass-throughs, and fire stops should be used when venting through combustible materials.

**NOTE:** Always take into consideration the effects of the prevailing wind direction or other wind currents that may cause flyash and/or smoke when placing the termination of the vent.

### In addition, the following must be observed:

- A. The clearance above grade must be a minimum of 12".
- B. The clearance to a window or door that may be opened must be a minimum of 48" to the side, 48" below the window/door, and 12" above the window/door.
- C. A 12" clearance to a permanently closed window is recommended to prevent condensation on the window.
- D. The vertical clearance to a ventilated soffit located above the terminal within a horizontal distance of 2 feet (60 cm) from the center-line of the terminal must be a minimum of 18".
- E. The clearance to an unventilated soffit must be a minimum of 12".
- F. The clearance to an outside corner is 11" from center of pipe.
- G. The clearance to an inside corner is 12".

H. A vent must not be installed within 3 feet (90 cm) above a gas meter/regulator assembly when measured from the horizontal center-line of the regulator.

I. The clearance to service regulator vent outlet must be a minimum of 6 feet.

J. The clearance to a non-mechanical air supply inlet to the building or the combustion air inlet to any other appliance must be a minimum of 48".

K. The clearance to a mechanical air supply inlet must be a minimum of 10 feet. **(with outside air installed, 6 feet)**

L. The clearance above a paved sidewalk or a paved driveway located on public property must be a minimum of 7 feet.

M. The clearance under a veranda, porch, deck or balcony must be a minimum of 12 inches. **(B. also applies)**

**NOTE:** The clearance to vegetation and other exterior combustibles such as mulch is 36" as measured from the center of the outlet or cap. This 36" radius continues to grade or a minimum of 7 feet below the outlet.

Certain Canadian and/or Local codes or regulations may require different clearances.

A vent shall not terminate directly above a side-walk or paved driveway which is located between two single family dwellings and serves both dwellings.

Only permitted if veranda, porch, deck, or balcony is fully open on a minimum of 2 sides beneath the floor.

**NOTE:** Where passage through a wall, or partition of combustible construction is desired, the installation shall conform to CAN/CSA-B365. (if in Canada)

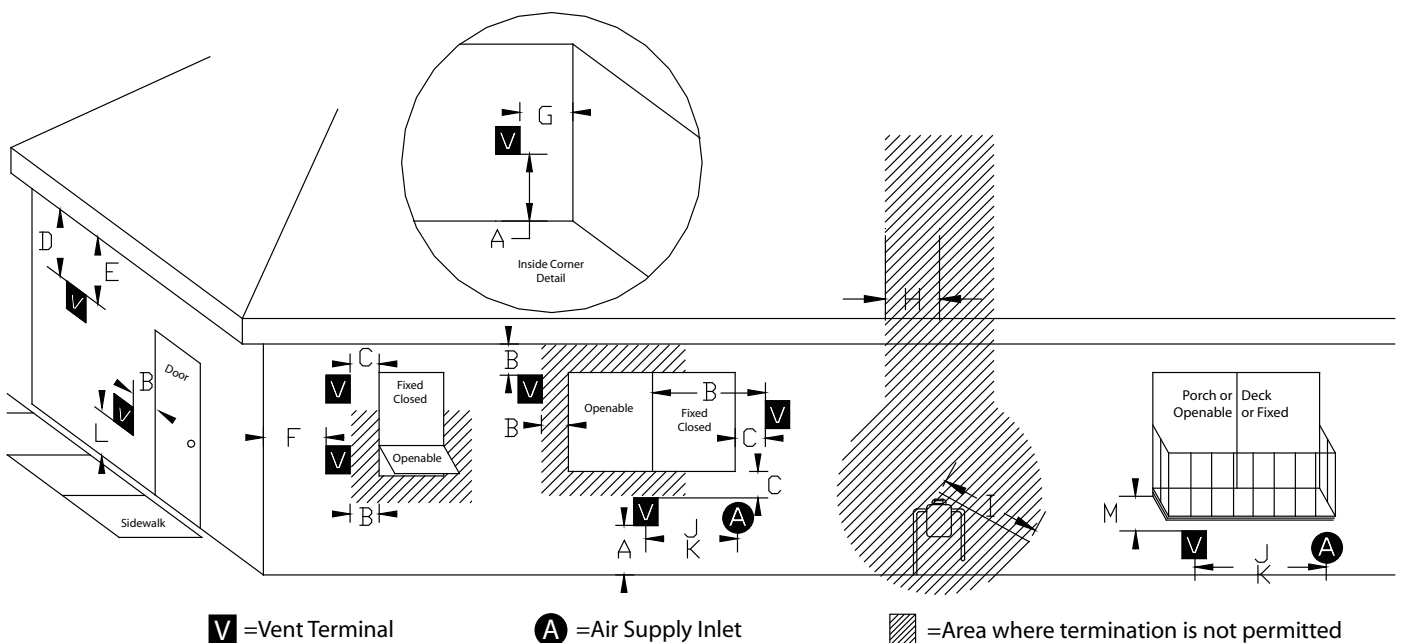

# Venting

## IMPORTANT NOTICE

Approved 3" or 4" Pellet Vent Pipe Such As, Type "PL", Must Be Used.

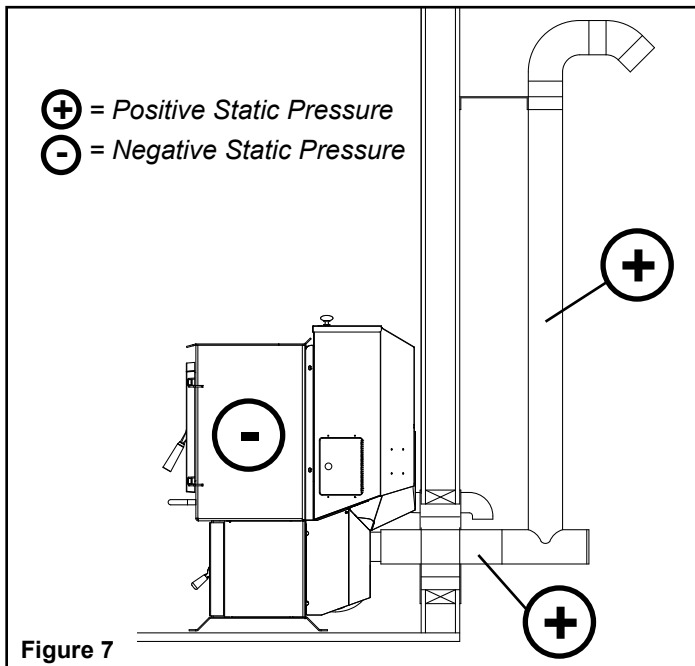

## Venting

A combustion blower is used to extract the combustion gases from the firebox. This causes a negative pressure in the firebox and a positive pressure in the venting system as shown in Figure 7. The longer the vent pipe and more elbows used in the system, the greater the flow resistance. Because of these facts we recommend using as few elbows as possible and 15 feet or less of vent pipe. The maximum horizontal run should not exceed 48". If more than 15 feet of pipe is needed, the interior diameter should be increased from 3" to 4" because a larger pipe causes less flow resistance. **Be sure to use approved pellet vent pipe wall and ceiling pass-through fittings to go through combustible walls and ceilings. All joints for connector pipe must be fastened with a minimum of three screws and a termination cap must be installed. Follow pellet vent manufacturer instructions for properly securing each pellet vent joint. The pellet starting collar must be secured to the unit's flue collar.**

**NOTE:** Simpson DuraVent PelletVent Pro Harman Adapter Part #3PVP-ADHB and PelletVent Pro Harman Adapter Inceaser Part #3PVP-X4ADHB are highly recommended to be installed on the starter collar to insure a proper pipe connection to the unit.

**A CHIMNEY CONNECTOR MAY NOT PASS THROUGH AN ATTIC OR ROOF SPACE, CLOSET OR SIMILAR CONCEALED SPACE, FLOOR, OR CEILING. REFERENCE LOCAL BUILDING CODES FOR DETAILS.**

## Vent Pipe

Pellet venting pipe (known as PL vent) is constructed of two layers with air space between the layers. This air space acts as an insulator and reduces the outside surface temperature to allow a clearance to combustibles of 1 to 3 inches. The sections of pipe lock together to form an air tight seal in most cases. However, in some cases a perfect seal is not achieved. For this reason and the fact that the unit operates with a positive vent pressure **we specify that the joints also be sealed with high temp (RTV) silicone.** Aluminum tape can also be used for any joint that is 1ft. or more from the outlet of the stove.

**INSTALL VENT AT CLEARANCES SPECIFIED BY THE VENT MANUFACTURER**

**DO NOT INSTALL A FLUE DAMPER IN THE EXHAUST VENTING SYSTEM OF THIS UNIT.**

**DO NOT CONNECT THIS UNIT TO A CHIMNEY FLUE SERVING ANOTHER APPLIANCE**

## CAUTION

**DO NOT USE MAKESHIFT COMPROMISES WHEN INSTALLING THIS APPLIANCE. DAMAGE AND/OR INJURY MAY RESULT.**

## Avoiding Smoke and Odors

### Negative Pressure, Shut-down, and Power Failure:

**To reduce the probability of back-drafting or burn-back in the pellet burning appliance during power failure or shut-down conditions, the stove must be able to draft naturally** without exhaust blower operation. Negative pressure in the house will resist this natural draft if not accounted for in the pellet appliance installation.

Heat rises in the house and leaks out at upper levels. This air must be replaced with cold air from outdoors, which flows into lower levels of the house. Vents and chimneys into basements and lower levels of the house can become the conduit for air supply, and reverse under these conditions.



# Venting

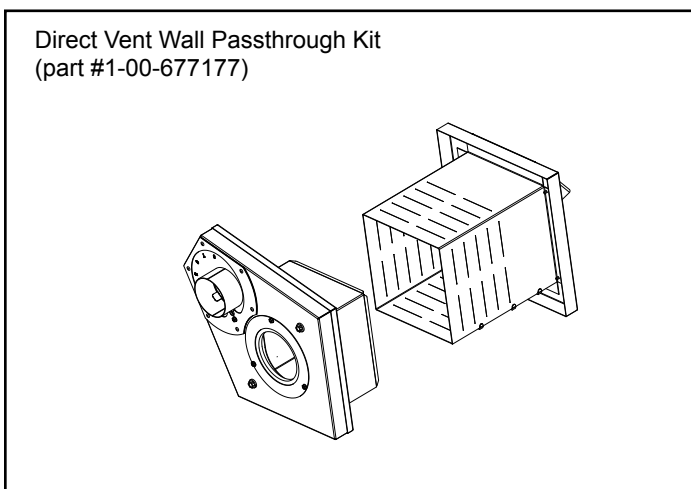
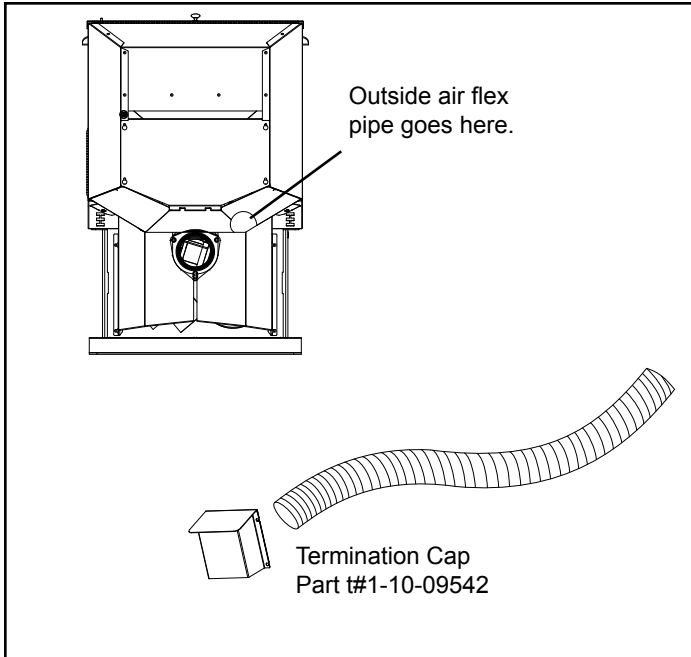

## Outside Air:

**Hearth & Home Technologies strongly recommends attaching outside air in all installations, especially lower level and main floor locations.**

Per national building codes, consideration must be given to combustion air supply to all combustion appliances. Failure to supply adequate combustion air for all appliance demands, may lead to back-drafting of those and other appliances.

When the appliance is side-wall vented: The air intake is best located on the same exterior wall as the exhaust vent outlet and located lower on the wall than the exhaust vent outlet.

When the appliance is roof vented: The air intake is best located on the exterior wall oriented towards the prevailing wind direction during the heating season.

The outside air connection will supply the demands of the pellet appliance, but consideration must be given to the total house demand. House demand may consume some air needed for the stove, especially during a power failure. It may be necessary to add additional ventilation to the space in which the pellet appliance is located. Consult with your local HVAC professional to determine the ventilation demands for your house.

To install outside air use 3" non-combustible flex pipe. There is a break-away hole on the rear panel of the stove which must be removed to connect the flex pipe. The maximum length run of this pipe is 15 feet. If a longer run is needed the size must be increased to 3". Termination Cap part number 1-10-08542 should be used to keep birds, rodents, etc. out of the pipe unless the Harman wall passthrough is being used.

## Direct Vent Wall Passthrough

The Harman Direct Vent Wall Passthrough (Part # 1-00-677177) makes installing your Harman Pellet Stove with outside air easier. It combines the needed wall protection for the venting, with a source of intake air for combustion. It is made to fit walls from 4 1/2" to 10 1/8" thick with a single square opening in the wall of 6-1/2 inches.

**NOTICE:** In Canada, ULC-S627 requires that all outdoor-aired space heaters be secured to the structure.

## Vent Configurations:

To reduce probability of reverse drafting during shut-down conditions, Hearth & Home Technologies strongly recommends:

- Installing the pellet vent with a minimum vertical run of five feet, preferably terminating above the roof line.
- Installing the outside air intake at least four feet below the vent termination.

To prevent soot damage to exterior walls of the house and to prevent re-entry of soot or ash into the house:

- Maintain specified clearances to windows, doors, and air inlets, including air conditioners.
- Vents should not be placed below ventilated soffits. Run the vent above the roof.
- Avoid venting into alcove locations.
- Vents should not terminate under overhangs, decks or onto covered porches.
- Maintain minimum clearance of 12 inches from the vent termination to the exterior wall. If you see deposits developing on the wall, you may need to extend this distance to accommodate your installation conditions.

**Hearth & Home Technologies assumes no responsibility for, nor does the warranty extend to, smoke damage caused by reverse drafting of pellet appliances under shut-down or power failure conditions.**

# Venting

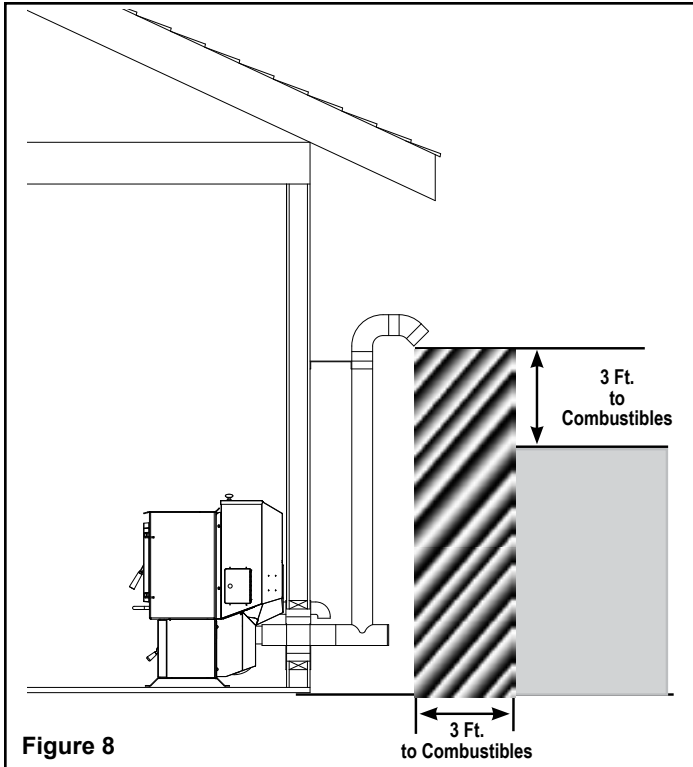

## #1 Preferred method

This method provides excellent venting for normal operation and allows the stove to be installed closest to the wall. Two inches from the wall is safe; however, four inches allows better access to remove the rear panel. The vertical portion of the vent should be three to five feet high. This vertical section will help provide natural draft in the event of a power failure.

**Note: Do not place joints within wall pass-throughs.**

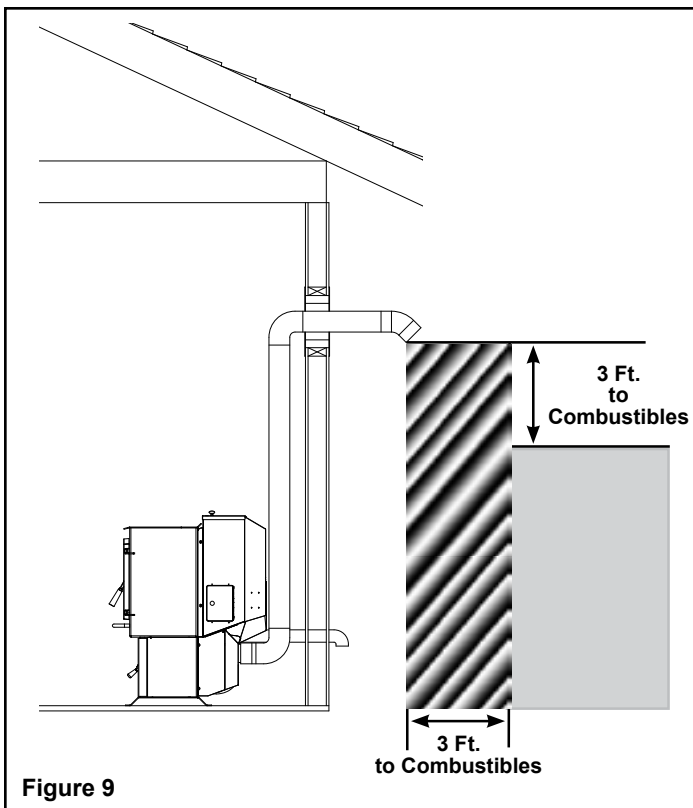

## #2 Preferred method

This method also provides excellent venting for normal operation but requires the stove to be installed farther from the wall. The vertical portion of the vent should be three to five feet high and at least three inches from a combustible wall. This vertical section will provide natural draft in the event of a power failure.

If the stove is installed below grade be sure the vent termination is at least 12" above grade. The outlet must also be 1 foot from the house/building.

**Note: Do not place joints within wall pass-throughs.**



**CAUTION**

Keep combustible materials (such as grass, leaves, etc.) at least 3 feet away from the flue outlet on the outside of the building.

# Venting

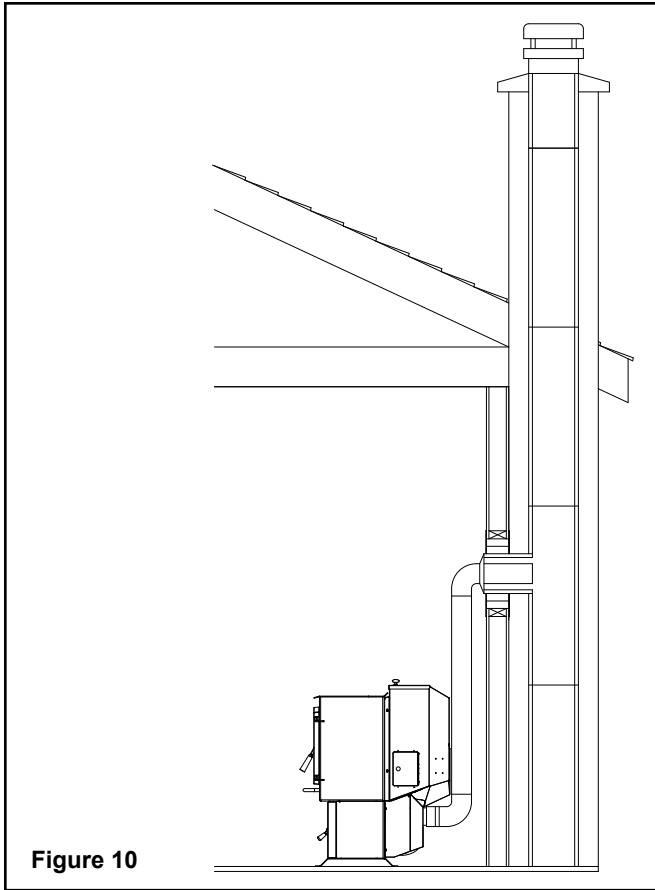

Figure 10

## #3 Installing into an existing chimney

This method provides excellent venting for normal operation. This method also provides natural draft in the event of a power failure. If the chimney condition is questionable\* you may want to install a liner as in method #6.

In some places in the US and Canada it is required that the vent pipe extend all the way to the top of the chimney.

\*The chimney should be inspected and cleaned before installing your stove. If you discover that the chimney does not have a clay tile liner or has cracks or flaking of the tile liner you will need to install a stainless steel liner within the chimney. In most cases the inside diameter of this liner should be 4". Either flexible or rigid liner may be used for this purpose.

Be sure to design the venting so that it can be easily cleaned.

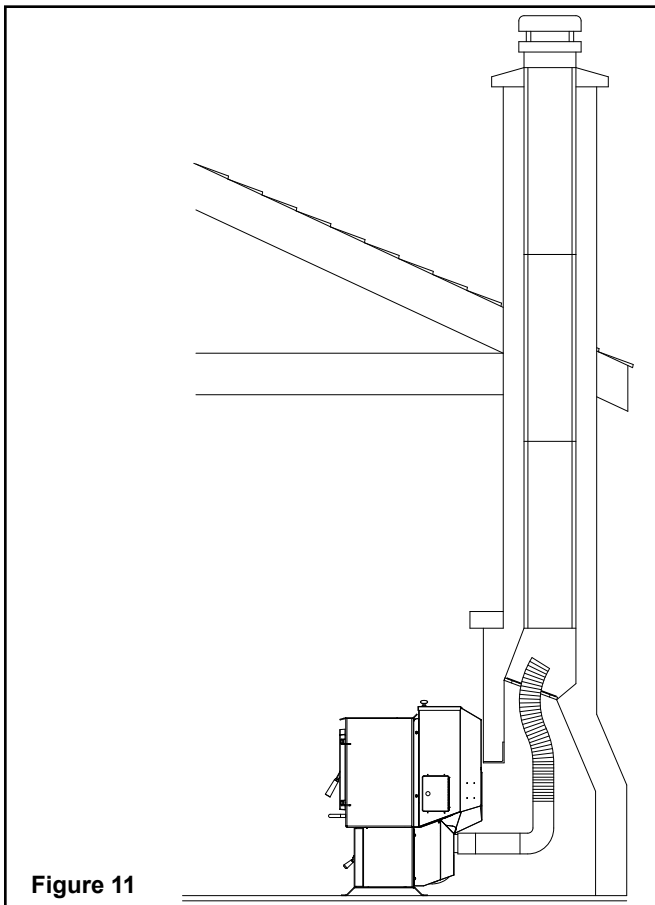

Figure 11

## #4 Installing into an existing fireplace chimney

This method provides excellent venting for normal operation. This method also provides natural draft in the event of a power failure. If the chimney condition is questionable\* you may want to install a liner as in method #5.

In some places in the US and Canada it is required that the vent pipe extend all the way to the top of the chimney.

\*The chimney must be inspected and cleaned before installing your stove. If you discover that the chimney does not have a clay tile liner or has cracks or flaking of the tile liner you will need to install a stainless steel liner within the chimney, as shown in Method 5.

The chimney must be sealed at the damper using a steel plate. Kaowool, mineral wool or other non-combustible insulation is recommended above the plate to reduce the possibility of condensation. The connector pipe should extend through the smoke chamber to the base or into the first flue tile.

Be sure to design the venting so that it can be easily cleaned.

# Venting

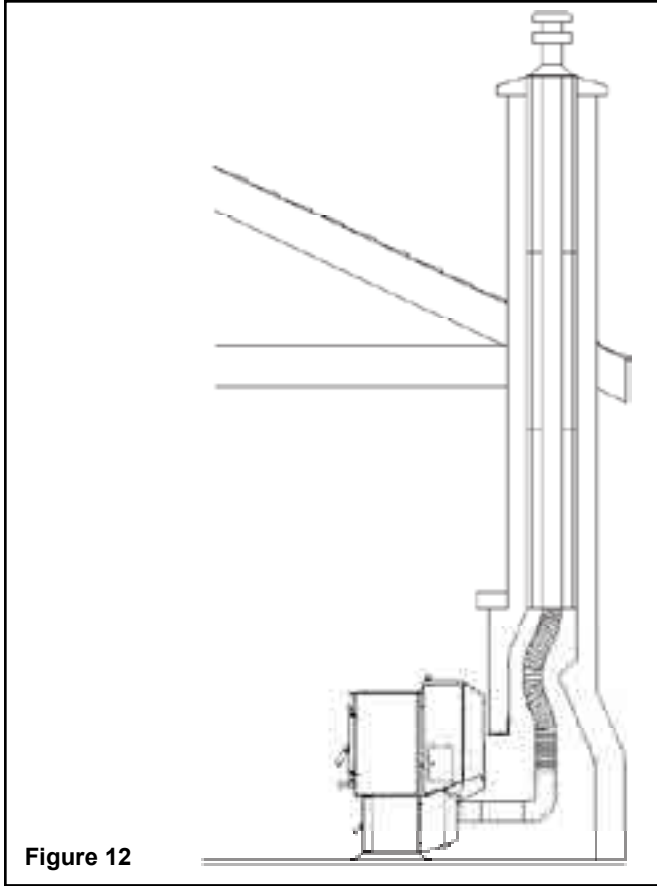

Figure 12

## #5 Installing into an existing fireplace chimney w/full liner

This method provides excellent venting for normal operation. This method also provides natural draft in the event of a power failure.

In some places in the US and Canada it is required that the vent pipe extend all the way to the top of the chimney. The pipe or liner inside the chimney should be 4" diameter.

In this method a cap should also be installed on the chimney to keep out rain. Be sure to use approved pellet vent pipe fittings. Seal pipe joints with silicone or aluminum tape in addition to the sealing system used by the manufacturer. Pipe size should be increased to 4" using this method.

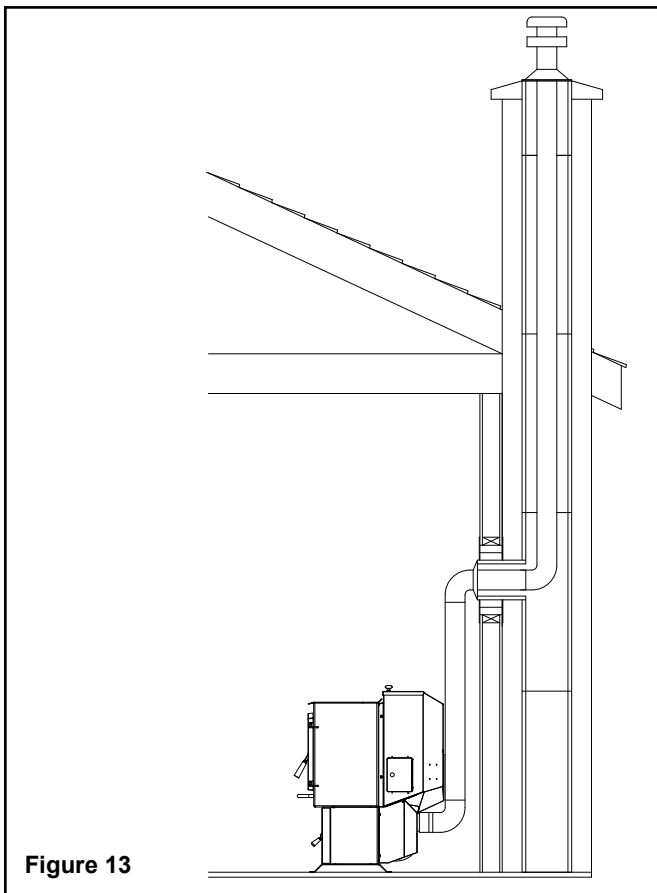

Figure 13

## #6 Installing into an existing chimney w/full liner

This method provides excellent venting for normal operation. This method also provides natural draft in the event of a power failure.

In some places in the US and Canada it is required that the vent pipe extend all the way to the top of the chimney. The pipe or liner inside the chimney should be 4" diameter.

In this method a cap should also be installed on the chimney to keep out rain.

# Venting

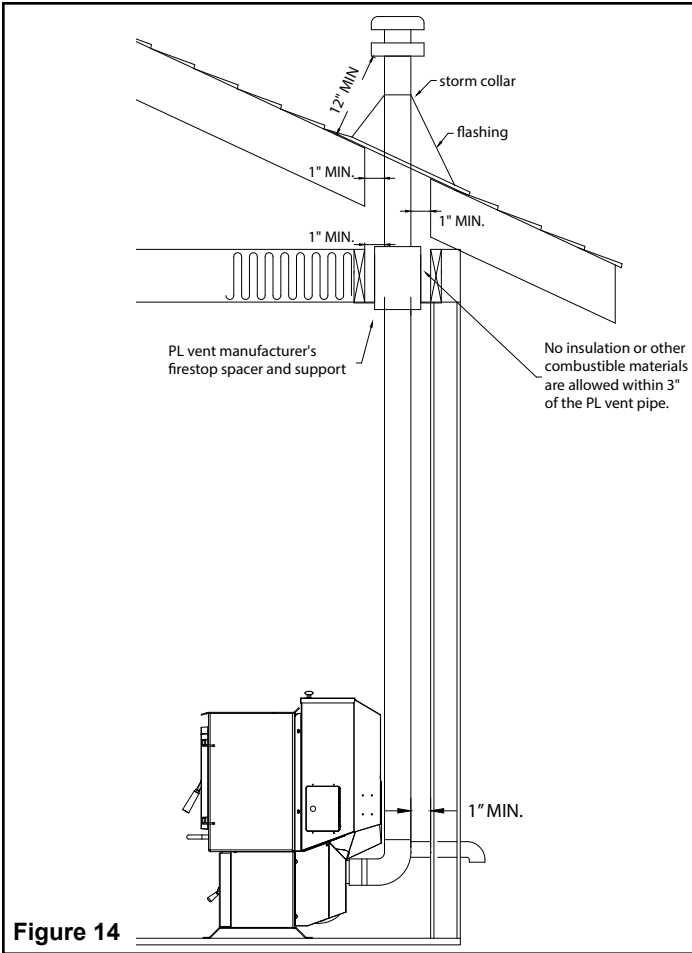

Figure 14

## #7 Installing through the ceiling

Through the ceiling vent, follow PL vent manufacturers recommendations when using wall and ceiling pass through.

**Note: Do not place joints within wall pass-throughs.**

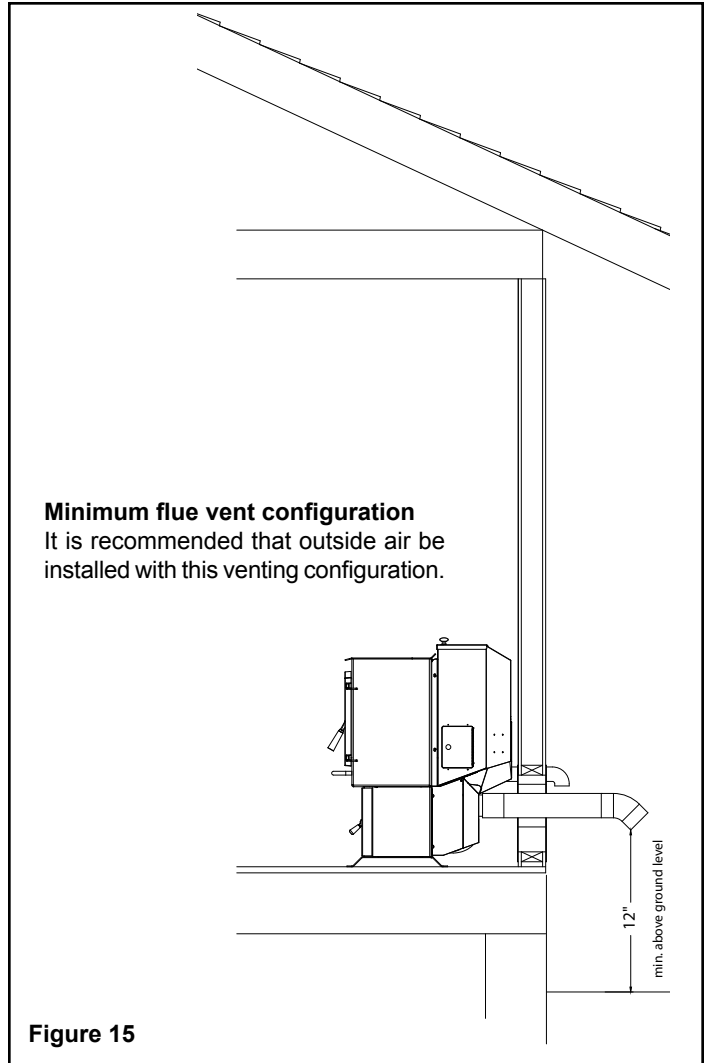

Figure 15

**Minimum flue vent configuration**  
It is recommended that outside air be installed with this venting configuration.

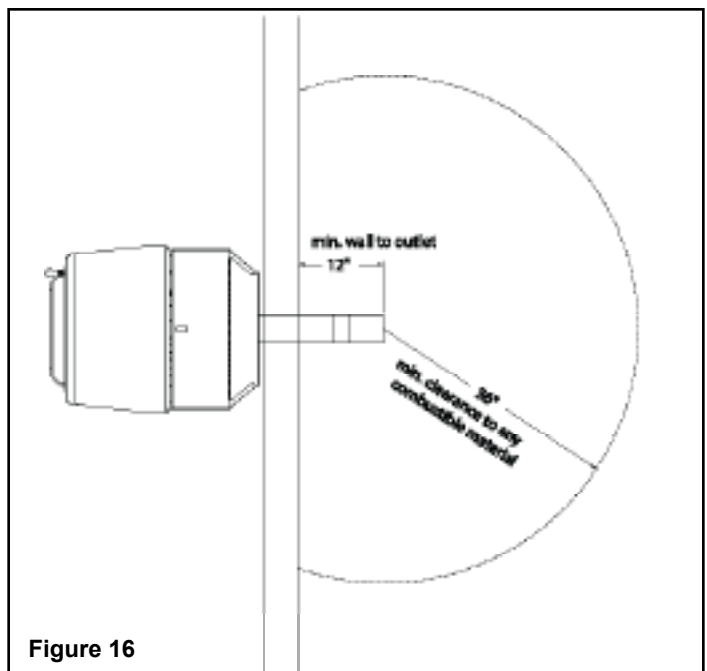

Figure 16

# ESP Control

## Power Light

Indicates power to the control.

## Status Light

Will be lit in either stove or room temp mode when pointer is not within off position band except after normal shut down. Blinks to indicate errors listed below.

Indicates power to Distribution Blower.

Indicates power to Combustion Blower

Indicates power to the Feed Motor.

Indicates Igniter is on.

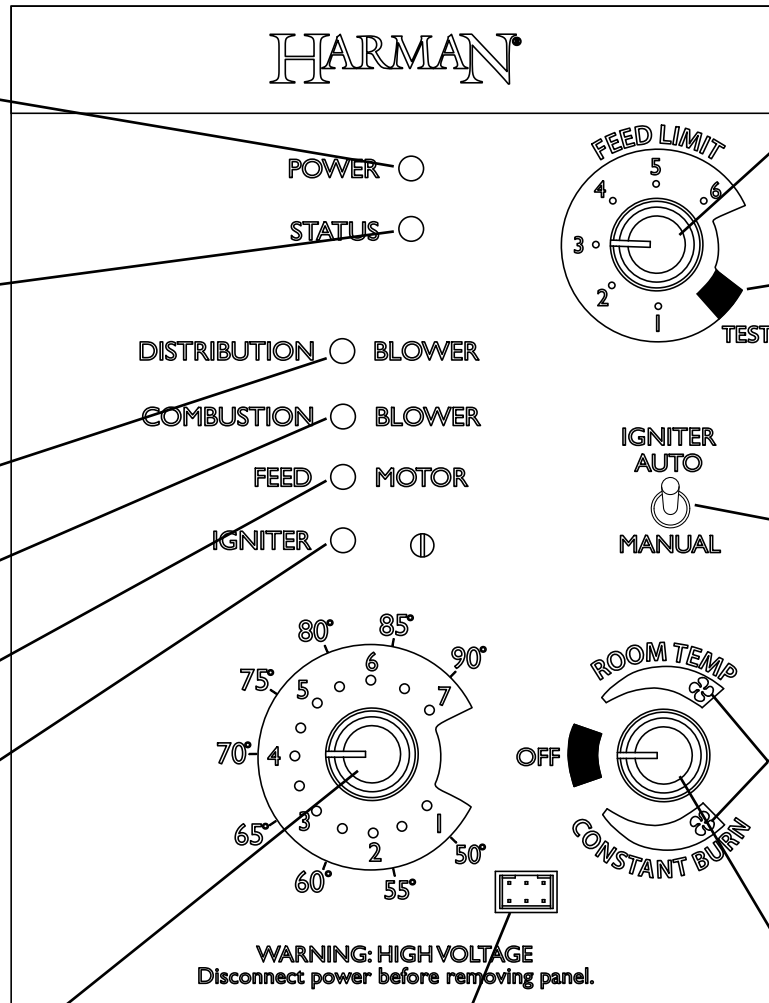

## Feed limit

Sets the maximum feed rate

## Test

Runs all motors at full speed for one minute to check operation. Afterwards the control will simulate a minimum burn with the combustion blower remaining on low.

## Igniter switch

Set to appropriate Start-Up mode.

Distribution Blower speed adjustment range.

L = low  
H = high  
Variable speed anywhere between L and H; although as the Constant Burn goes up, so does the L and H scale.

## Temp dial

Allows you to adjust the room temperature setting, in Room Temp Mode, using the outer scale marked in degrees Fahrenheit. It also allows you to adjust the constant burn setting, while in Constant Burn Mode, using the inner scale marked from 1 to 7.

## Dealer Diagnostic Port

For dealer maintenance only. Requires special DDM monitor supplied to Harman® Dealers exclusively.

## Mode Selector

Allows you to choose between Room Temp Mode, Constant Burn Mode, or OFF. Also allows you to vary the distribution blower speed by turning the knob to the high or low side of each mode.

## Status light error messages:

**3 Blinks:** Indicates that the ESP (Exhaust Sensing Probe) has lost communication with the circuit board, or has gone out of range more than allowed in a specified time. If the unit seems to be operating properly, perform a manual reset\*. If the code persists, contact your dealer.

**4 Blinks:** Can occur only in Room Temp Mode and indicates Room Sensing Probe failed or not installed. If a Room Sensing Probe is then installed, the status light will automatically reset.

**5 Blinks (In Igniter Auto. Mode Only):** Indicates that the unit has failed to light within the 36 minute start cycle. To reset - Turn Mode Selector to "OFF", then turn to either mode again.

**6 Blinks:** Indicates that the control has calculated poor or incomplete combustion occurring for more than 25 minutes.

A six blink status may be set if the stove is allowed to run out of pellets. To reset, turn mode selector to "OFF" then back on to the desired mode. If the unit was not out of pellets, see Troubleshooting section for more details.

\* **Manual reset**- disconnect power cord for a few seconds and reconnect. If error still occurs call your Dealer.

# Automatic Operation

The P61A is a fully automatic stove that features two operating modes; **Constant Burn Mode** and **Room Temperature Mode**. In Constant Burn Mode, you select a burn rate and the stove will remain at the same burn rate regardless of the room temperature.

In the Room Temperature Mode the stove constantly monitors the temperature in the room and adjusts the size of the fire and the heat output of the stove so that the room is kept at a constant temperature. Room mode, in the AUTO position, has the added advantage of turning the stove off if no heat is required and turning the stove on again when the room temperature drops below your desired room temperature.

## Room Temperature Mode

Most consumers use the stove in the Room Temperature Mode because it is the easiest and most efficient method of keeping the room at a given temperature. In the Room Temperature Mode, the Room Sensing Probe constantly monitors room temperature. As the weather changes outside and your home needs varying amounts of heat to be at a desired temperature, the stove will automatically increase fire size and heat output so that a constant even temperature is maintained. If the weather warms up and no heat is required, the stove will gradually shut down. When the house cools down, the stove will automatically bring the room temperature to the precise temperature you desire.

In the Room Temperature Mode you can select either **Auto or Manual modes** for the **igniter**, using the igniter toggle switch. When the toggle switch is in the Auto position, the igniter, located inside the burn pot, is ready to automatically light the fire when required. When the toggle switch set to the Manual position the stove can be lit manually with either a gel or a wax type fire starter. (see lighting instructions on page 19.) With the igniter toggle switch set in the Manual position the stove will automatically adjust heat output, but the stove will not automatically shut down if no heat is required. Instead it will go to its lowest setting and remain there. The Manual position on the igniter toggle switch lets you light the stove manually, should the igniter fail for any reason. Secondly if you are using the Harman battery back up system, the Manual setting will prevent the stove from turning off and on during a power failure, which would drain the back up battery, and possibly cause damage to the back-up or the stove.

In the Room Temperature Mode, the distribution blower speed can be increased or decreased by adjusting the Room Temp/Off/Constant Burn dial between L and H. As output of the stove increases, the speed of the blower will increase automatically to insure that more heat is transferred out into the room. The distribution blower will shut off as the room reaches the set temperature, this will prevent overheating of the room.

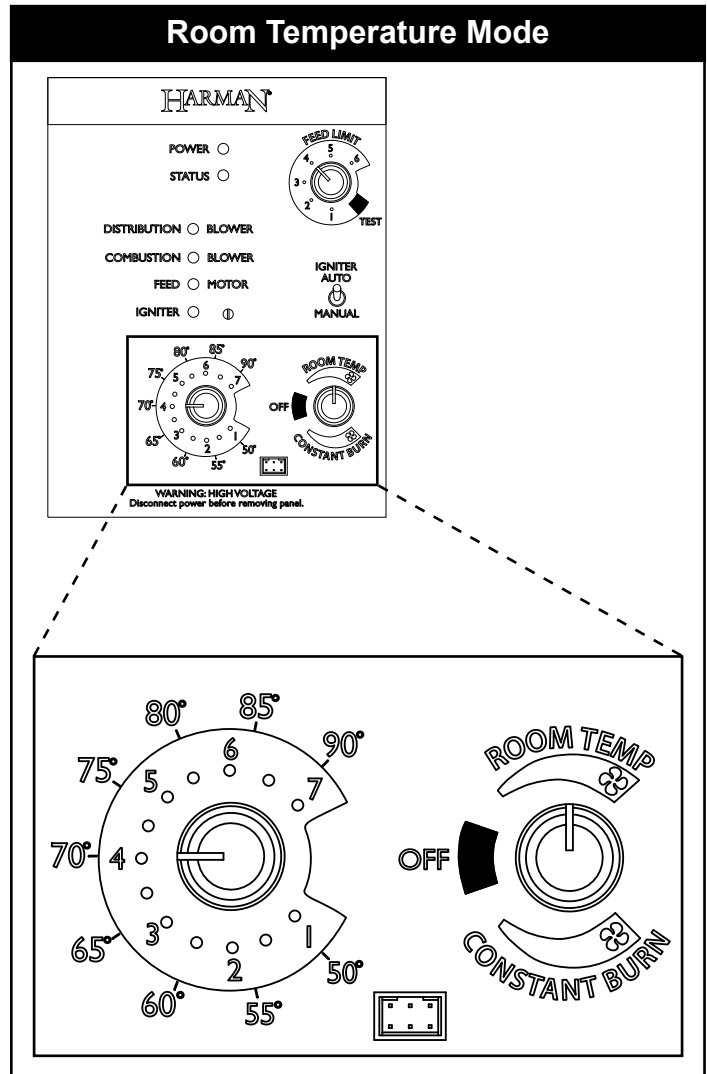

**Room Temperature Mode:** This setting, see above, will produce a room temperature of 70 degrees with the distribution blower at medium speed.

## CAUTION

**DO NOT CONNECT TO ANY AIR DISTRIBUTION DUCT OR SYSTEM.**

**DO NOT BURN GARBAGE OR FLAMMABLE FLUIDS SUCH AS GASOLINE, NAPHTHA, OR ENGINE OIL.**

**HOT WHILE IN OPERATION. KEEP CHILDREN, CLOTHING, AND FURNITURE AWAY. CONTACT MAY CAUSE SKIN BURNS.**

**KEEP FIREBOX AND ASH REMOVAL DOORS CLOSED DURING OPERATION. MAINTAIN SEALS IN GOOD CONDITION.**

# Automatic Operation

## Constant Burn Mode

In the Constant Burn Mode and with the igniter toggle switch in the Auto position, the stove will light automatically and can be adjusted to the desired setting using the same temperature control dial as is used in the Room Temperature Mode. The heat output and fuel consumption will remain constant regardless of room temperature. The settings from 1 to 7 on the inner ring of the temperature dial provide for relative heat output settings with 1 being low and 7 being the maximum.

In Constant Burn Mode, the stove will not automatically shut off unless the stove runs out of fuel or is turned off.

Never pull the plug to shut down the stove. This will stop the combustion blower and smoke will escape through window and door gaskets.

When the igniter toggle switch is set to manual in this mode, the distribution blower will not turn on with a temperature dial setting from 1 to 5. The advantage of this mode is to allow the operator to have a large viewing fire without blowing extra heat into the room.

During manual operation, with the temperature dial set at #4 or less, the distribution fan will not operate. A #4 on the temperature dial and a #5 on the feed limit is approximately 80% output. It is not necessary to operate the distribution blower below this point. Therefore, the control allows a higher burn rate (a larger viewing fire) without an excess of hot air blowing into the room.

An example of when to use the Manual Constant Burn Mode is if you want to watch a large fire and the room is already up to temperature. The Constant Burn Mode allows you to have a larger fire and a lower sound level, without the distribution blower.

**NOTE:** During the use of this mode, if you keep increasing the temperature dial setting to increase the fire size, the distribution blower will automatically come on when the ESP Temperature reaches 350 °F, or 81% output.

## Feed limit Knob

For most premium grade pellet fuels the Feed limit Knob should be set at 4. If higher ash fuels are used the setting should be increased to 5 or 6. Also higher settings are required if you would like to get the maximum heat output from the stove. At the maximum burn rate (with the temperature dial on 7/90° and the feed limit at 6) there should be 1" or more of ash on the front of the burn pot. If there is less than 1" of ash, turn the feed limit knob down to a lower setting.

## Shut Down Procedure

The best way to shut down the stove is to simply let it run out of pellets. The stove will shut down automatically. Alternatively, you can turn the Mode Selector to "off". This will cause the fire to gradually die down and go out. The fire will not go out immediately and may take more than an hour to fully shut down.

If the stove is left to run out of fuel, you may get a 6 blink status light. If this happens simply reset the control board by turning the mode selector to OFF and back ON.



**CAUTION**

**HOT WHILE IN OPERATION. KEEP CHILDREN, CLOTHING, AND FURNITURE AWAY. CONTACT MAY CAUSE SKIN BURNS.**

## Constant Burn Mode

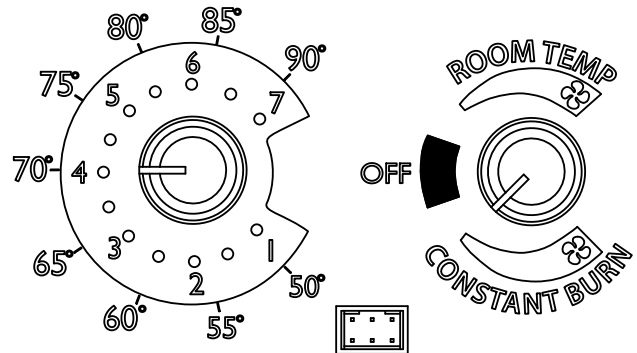

The setting above will produce continuous medium heat output with the distribution blower at low speed.

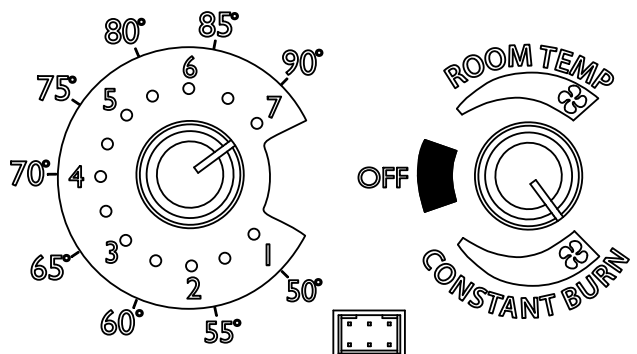

The setting above will produce continuous maximum heat output with the distribution blower at full speed.



# Automatic Start Up

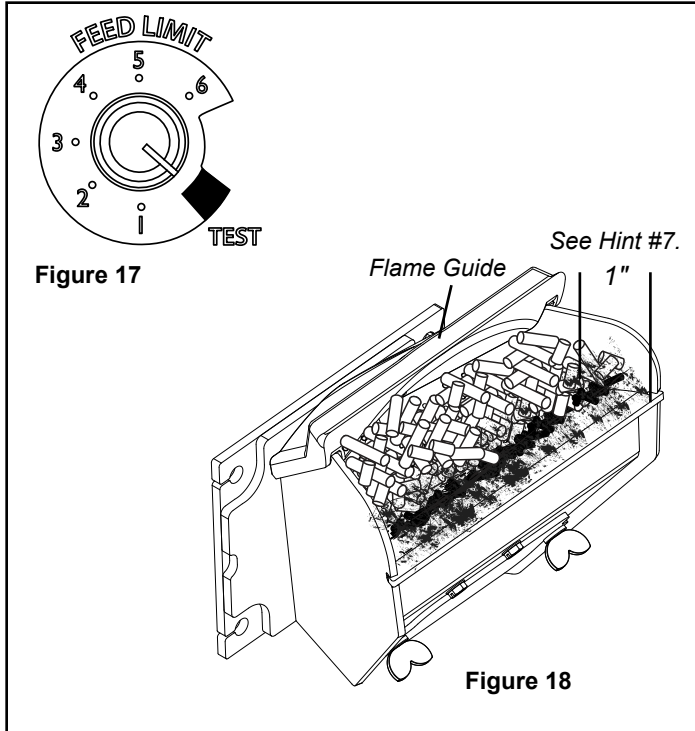

## Helpful Hints

1. Fines are small pieces of broken pellets (sawdust). Fines do not flow easily and often build up on the hopper funnel bottom angles. You can push these fines into the feeder opening and then fill the hopper with pellets. As the system works, they will be burned. Or you can clean them out before filling the hopper.
2. The "TEST" cycle will operate the feeder motor for exactly one minute. Turning to "TEST" again and again may charge too much fuel into the burn pot causing excessive smoke on start-up.
3. The firebox low pressure switch will not allow the auger motor or the igniter element to operate if the view door or the ash pan door are open.
4. Adjust Feed Rate. If this is your first fire or you are trying different pellets, set the feed limit to #4, Figure 17. This is a conservative number and will probably need to be increased. After you know a feed rate setting that works well, use that setting. Remember, if your feed rate is too high you may waste fuel.
5. This is usually a weekly maintenance procedure. Cleaning the burn pot with the scraper with a small amount of new fuel in the bottom is not a problem. First, scrape the ashes off the front of the burn pot into the ash pan. Then, scrape the top surface of the burn pot downward into the base of the burn pot. When the stove is ignited these scrapings will be pushed out by the feeder and burned.
6. The ash pan can hold the ashes from approximately 1 ton of premium fuel. This means the ashes will only need to be emptied a few times each year.
7. Setting the feed limit # for maximum burn: With the unit burning in "AUTO", turn to "Stove Mode" and put the fan on "H". Set the Temperature Dial to #7. Allow the unit to burn for about 30 minutes and check ash on front of burn pot. Figure 18. If the ash line is larger than 1", turn the feed limit from #4 to #5. Allow another 30 minutes of burn time and check again. If, at #6 setting, a 1" or less ash bed is not obtainable, it is not a problem. The 1" ash bed is only a maximum burn rate and at most normal settings the ash bed will be larger.

## Starting First Fire

### Igniter Switch to "AUTO" (up position)

Make sure the unit is plugged into a 100 VAC, 50 Hz electrical source. The power light should be the only light lit.

**NOTICE: Be sure there is no unburned fuel or other combustibles in the ash pan prior to lighting.**

1. Turn Mode Selector to "OFF".
2. Fill hopper with pellets.
3. Clean burn pot with scraper, if necessary.
4. If starting after an empty hopper, turn Feed limit to "TEST" (for one 60 second cycle). This will feed pellets into the auger tube and also allow you to check the motors for operation.

**NOTE: The auger motor will not operate with the view door or ash pan door open.**

5. Turn Feed limit to #4.
6. Flip the Igniter Switch up into the "AUTO" position.
7. Turn the Temperature Dial to the desired temperature.
8. Turn Mode Selector to Room Temperature or Constant Burn.
9. Fill hopper with pellets and remove ashes as required.

**KEEP THE APPLIANCE DOORS AND HOPPER LID CLOSED DURING OPERATION.**

## CAUTION

**DO NOT USE CHEMICALS OR FLUIDS TO START THE FIRE. FOR EXAMPLE: NEVER USE GASOLINE, GASOLINE-TYPE LANTERN FUEL, KEROSENE, CHARCOAL LIGHTER FLUID, OR SIMILAR LIQUIDS TO START OR "FRESHEN UP" A FIRE IN THIS HEATER. KEEP ALL SUCH LIQUIDS WELL AWAY FROM THE HEATER WHILE IT IS IN USE.**

# Manual Operation

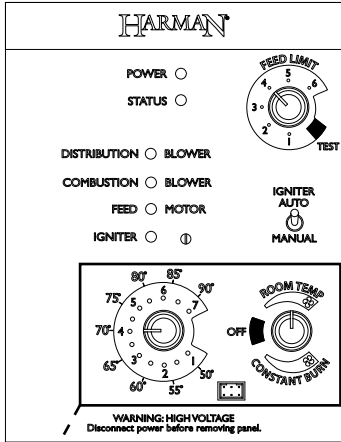

The P61A Pellet Stove is capable of manual operation. This also allows the operator to manually control operation during an emergency (i.e. igniter failure, when using a 502H battery backup, as opposed to the 512H, or when using certain generators.)

The unit can be switched between "AUTO" and "MANUAL" at any time during operation.

**Room Temperature Mode:** This setting, see below, will produce a room temperature of 70 degrees with the distribution blower at medium speed.

**NOTE:** When starting the unit in the "AUTO" mode and switching to "MANUAL", the ignition cycle must be allowed to begin prior to making the switch.

## Igniter Switch to "MANUAL"

### Room Temperature Mode

The fire will have to be lit with starting gel and a match, or started automatically, see "Starting First Fire" under the Automatic Start Up section. Turn to "Manual" position when the ignition cycle has started.

The difference between "AUTO" Room Temperature Mode and "Manual" Room Temperature Mode is that the fire will not go out as the room temperature goes above the control board setting. The unit can only go to low burn and will remain there until it runs out of fuel or until more heat is needed and the feed rate increases. Feed rate adjustments and dial settings are the same as "AUTO" settings. The blower will shut off completely if the temperature on the ESP is too low.

## Igniter Switch to "MANUAL"

### Constant Burn Mode

The advantage of this mode is to allow the operator to have a large viewing fire without blowing extra heat into the room.

During operation, with the temperature dial set at #5 or less, the distribution fan will not operate. A #5 on the temperature dial and a #5 on the feed limit is approximately 80% output. It is not necessary to operate the distribution blower below this point. This control setting allows a higher burn rate (a larger viewing fire) without an excess of hot air blowing into the room.

An example of when to use the Manual Constant Burn Mode is if you want to watch a large fire and the room is already up to temperature. The Constant Burn Mode allows you to have a larger fire and a lower sound level, without the distribution blower.

**NOTE:** During the use of this mode, if you keep increasing the temperature dial setting to increase the fire size, the distribution blower will automatically come on when the ESP Temperature reaches 350 °F, or 81% output.

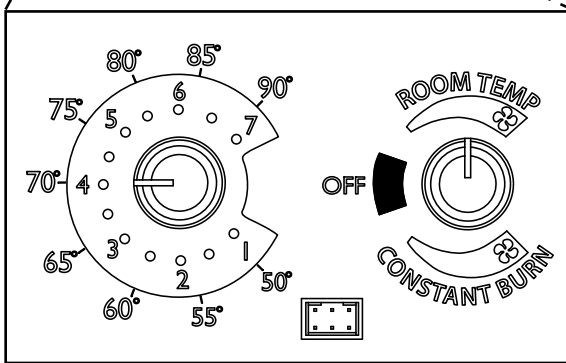

## Manual Constant Burn Mode

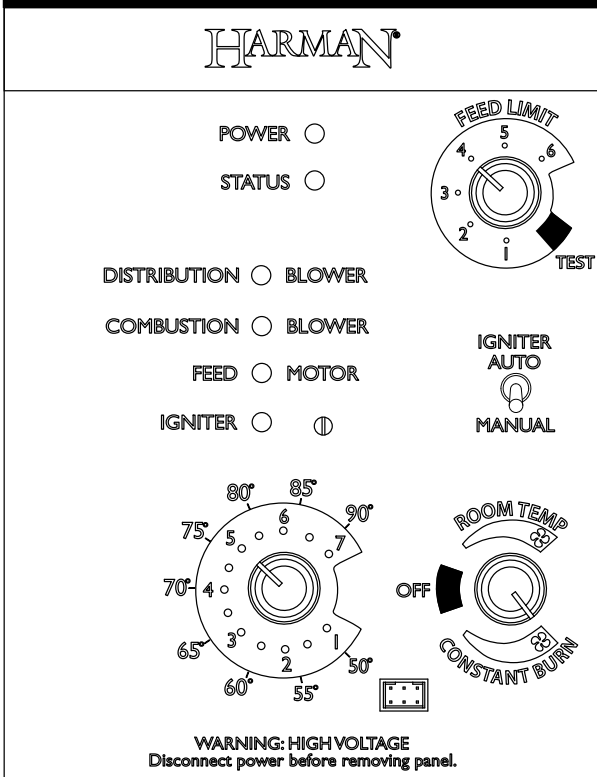

This setting will produce a large viewing fire without a distribution blower operating.

# Manual Operation

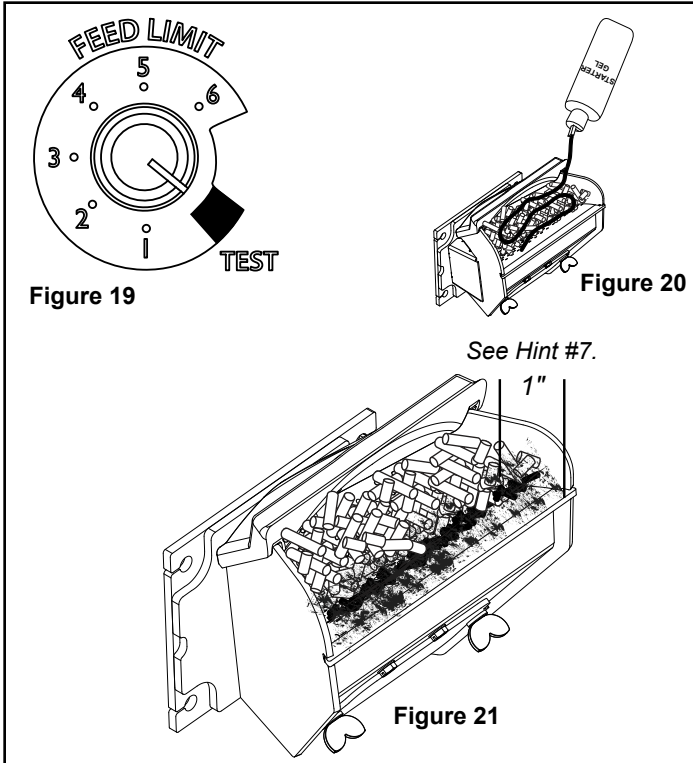

## Helpful Hints

1. Fines are small pieces of broken pellets (sawdust). Fines do not flow easily and often build up on the hopper funnel bottom angles. You can push these fines into the feeder opening and then fill the hopper with pellets. As the system works, they will be burned. Or you can clean them out before filling the hopper. As the system works, they will be burned.
2. The "TEST" cycle will operate the feeder motor for exactly one minute. Turning to "TEST" again and again may charge too much fuel into the burn pot causing excessive smoke on start-up.
3. The firebox low pressure switch will not allow the auger motor or the igniter element to operate if the view door or the ash pan door are open.
4. Adjust Feed Rate. If this is your first fire or you are trying different pellets, set the feed limit to #4, Figure 19. This is a conservative number and will probably need to be increased. After you know a feed rate setting that works well, use that setting. Remember, if your feed rate is too high you may waste fuel.
5. This is usually a weekly maintenance procedure. Cleaning the burn pot with the scraper with a small amount of new fuel in the bottom is not a problem. First, scrape the ashes off the front of the burn pot into the ash pan. Then, scrape the top surface of the burn pot downward into the base of the burn pot. When the stove is ignited these scrapings will be pushed out by the feeder and burned.
6. The ash pan can hold the ashes from approximately 1 ton of premium fuel. This means the ashes will only need to be emptied a few times each year.
7. Setting the feed limit # for maximum burn: With the unit burning in "AUTO", turn to "Stove Mode" and put the fan on "H". Set the Temperature Dial to #7. Allow the unit to burn for about 30 minutes and check ash on front of burn pot. Figure 21. If the ash line is larger than 1", turn the feed limit from #3 to #4. Allow another 30 minutes of burn time and check again. If, at #6 setting, a 1" or less ash bed is not obtainable, it is not a problem. The 1" ash bed is only a maximum burn rate and at most normal settings the ash bed will be larger.

## Starting First Fire

### Igniter Switch to "MANUAL" (down position)

Make sure the unit is plugged into a 100 VAC, 50 Hz electrical source. The power light should be the only light lit.

**NOTICE:** Be sure there is no unburned fuel or other combustibles in the ash pan prior to lighting.

1. Turn Feed limit to desired feed rate. No. 4 is good for most pellets.
2. Turn the MODE SELECTOR to "OFF" and then to the desired mode. This will reset control and start the combustion motor.
3. Turn the TEMPERATURE DIAL to the desired setting.
4. Clean burn pot with scraper if necessary.
5. Fill burn pot with pellets, only level with front edge. (Do Not Over Fill).
6. Add starting gel on top of the pellets. Stir gel into pellets for fast lighting.
7. Light starting gel with a match, and close the door. Operation will begin when the fire reaches the proper temperature.
8. Fill hopper with pellets and remove ashes as required.

**KEEP THE APPLIANCE DOORS AND HOPPER LID CLOSED DURING OPERATION.**



## WARNING

**"NEVER USE GASOLINE, GASOLINE-TYPE LANTERN FUEL, KEROSENE, CHARCOAL LIGHTER FLUID, OR SIMILAR LIQUIDS TO START OR "FRESHEN UP " A FIRE IN THIS HEATER. KEEP ALL SUCH LIQUIDS WELL AWAY FROM THE HEATER WHILE IN USE".**

# Low Draft Voltage Adjustment

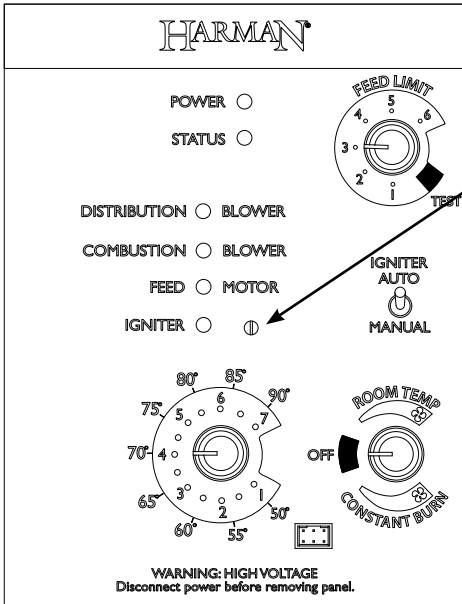

Figure 22

## Low Draft Voltage Adjustment

These units are pre-tested at the factory with exactly 100 VAC, 50 Hz. They are checked and adjusted for firebox tightness, gasket leakage, motor operation and igniter operation. The P61A is then factory set at a mid-point adjustment and in most cases will not need any adjustments. **NOTE: The factory low draft setting may not be correct for the unit's permanent installation conditions.**

The control board on the P61A is equipped with a low draft adjustment port. Located on the control face just to the right of the igniter light. This voltage adjustment is provided to allow the unit to be adjusted for the household voltage where the unit is going to be in permanent operation. **NOTE: The line voltage varies from area to area and often home to home.**

The low draft voltage should be adjusted to achieve the most efficient burn on low burn or "maintenance". This voltage adjustment allows the installer to change the low voltage set point approximately 10 volts. This adjustment should be done by the installer during set up because a draft meter reading is **required** to insure proper set up.

If the unit is not adjusted properly, it does not cause a safety concern. If the unit is adjusted too high, only efficiency is lost. If the unit is adjusted too low, the low draft pressure switch will not allow the feed motor or the igniter to operate.

## Combustion Motor Speed Control

**Low draft only set point.**

*The small straight screwdriver slot is plastic; therefore, the unit can be adjusted while in operation.*

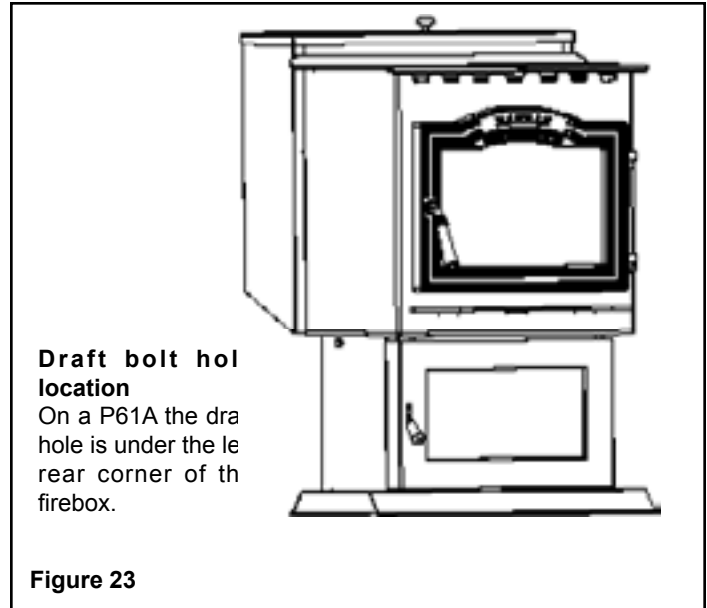

Figure 23

A simple draft test should be performed after completing the flue pipe installation. To record the results for future reference:

1. Plug unit into a 100 VAC, 50 Hz outlet.
2. Close the hopper lid, front view door, and the ash pan. Neither pellets or a fire are required for this test.
3. With the mode selector in the "OFF" position, turn the feed limit to "TEST".
4. Record the high draft \_\_\_\_\_ in W.C. (Normal is -.50 to -.60) The control will be on the High Draft for a total of 1 minute.
5. After the minute, the combustion motor will go down to low draft and the distribution blower will go on high. Allow approximately 15 seconds to pass for the combustion motor to slow before checking the low draft.
6. If the low draft is between -.35 and -.45, record the reading \_\_\_\_\_ in W.C. If the reading is higher, slowly turn the set screw counter-clockwise until the draft lowers. If the reading is lower, very slowly turn the set screw clockwise until the draft increases.

**NOTE: In some cases, the draft may not go as low as -.35 to -.45 even with the set screw completely counter-clockwise. Ideally, you should just set it as low as possible.**

# Maintenance

## Minimizing Creosote:

Whenever wood is burned slowly, the potential exists for creosote to form in the venting. The chimney or venting system should be inspected periodically throughout the heating season to determine if a creosote buildup has occurred. If a significant layer of creosote has accumulated (3mm or more), it should be removed to reduce the risk of a chimney fire. A professional chimney sweep is recommended, since they would normally have the correct equipment to ensure proper creosote removal.

**If you experience a fire in the venting system**, turn the stove to "OFF" to allow the unit to shut down. Call the fire department, and be sure everyone is out of the residence. Before re-using the appliance, have it, and the venting system thoroughly inspected and replace any damaged components.

The glass in your Harman stove is a special 5mm ceramic glass.

- Do not abuse the glass by striking or slamming the door.
- Never burn the appliance if the door glass is cracked or broken.
- Replace only with Harman supplied glass. Do NOT Use Substitutes.

Soot and/or fly-ash may accumulate on the viewing glass, and will occasionally need to be cleaned. Clean the glass with a soft cloth and mild glass cleaner. Do not clean the glass when hot, and avoid the use of abrasive cleaners.

### Glass replacement

Carefully remove all remaining glass and gasket materials prior to replacing the glass.

Lay the door face down on a flat surface. Remove the glass retainers and screws. Apply the gasket material to the face of the new glass. Lay the glass into the door, making sure that the glass is contained within the channels and raised areas of the door itself. Lay the glass retainers into position and install the screws. Tighten each screw evenly to avoid making any stress points.

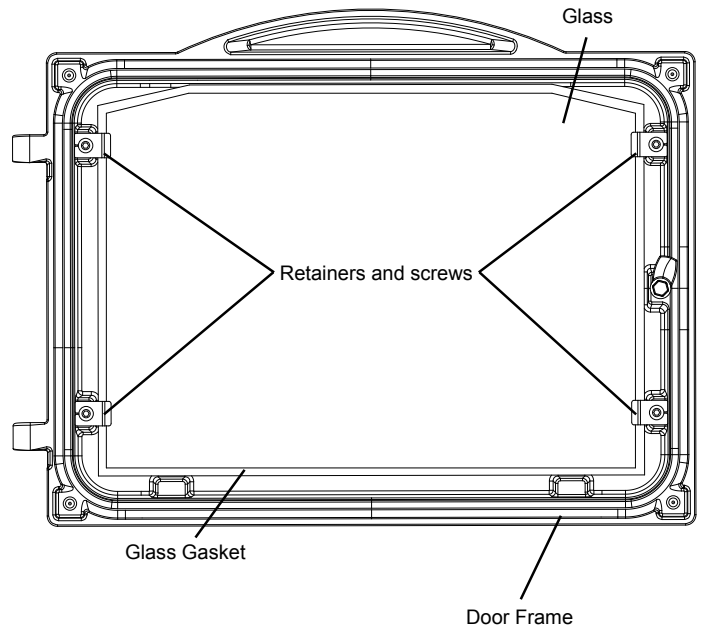

## ⚠ WARNING



**INSPECT APPLIANCE AND COMPONENTS FOR DAMAGE. DAMAGED PARTS MAY IMPAIR SAFE OPERATION.**

- DO NOT INSTALL DAMAGED COMPONENTS.
- DO NOT INSTALL INCOMPLETE COMPONENTS.
- DO NOT INSTALL SUBSTITUTE COMPONENTS.

**REPORT DAMAGED PARTS TO DEALER.**

## ⚠ WARNING



**FIRE RISK.**

**HEARTH & HOME TECHNOLOGIES DISCLAIMS ANY RESPONSIBILITY FOR, AND THE WARRANTY WILL BE VOIDED BY, THE FOLLOWING ACTIONS:**

- INSTALLATION AND USE OF ANY DAMAGED APPLIANCE.
- MODIFICATION OF THE APPLIANCE.
- INSTALLATION OTHER THAN AS INSTRUCTED BY HEARTH & HOME TECHNOLOGIES.
- INSTALLATION OF PARTS OR COMPONENTS NOT SUPPLIED OR APPROVED BY HEARTH & HOME TECHNOLOGIES.
- OPERATING APPLIANCE WITHOUT FULLY ASSEMBLING ALL COMPONENTS.

**OR ANY SUCH ACTION THAT MAY CAUSE A FIRE HAZARD.**

# Maintenance

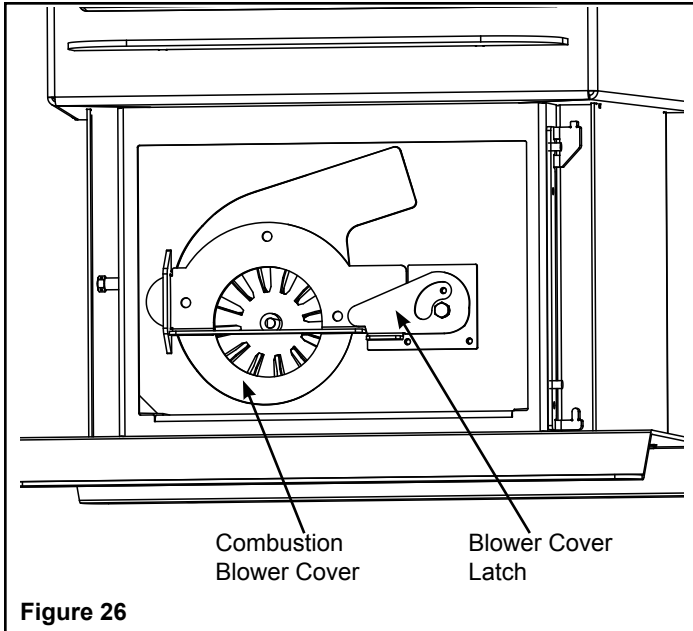

## Scraping the burn pot:

Whenever adding fuel to the hopper, take the time and scrape the grate surface of the burnpot, using the scraper tool provided. This can be done while a fire is burning. Wearing heat resistant gloves, open the firebox door. Scrape any accumulated ashes from in front of the fire, into the ash pan. Now, scrape under the fire, in a downward direction, to loosen any carbon deposits. Do not scrape the fire out of the pot. Whatever you loosen will be pushed out with the flow of new fuel into the pot. (Figure 33)

## Ash Removal

Due to potential high temperatures, it is recommended that the stove be out and cool prior to removing the ash pan. Open the front door and grasp the ash pan by the handle. With the ash pan removed, swing the handle upward for carrying.

**Disposal of Ashes-** Ashes should be placed in a steel container with a tight fitting lid. The closed container of ashes should be moved outdoors immediately and placed on a noncombustible floor or on the ground, well away from all combustible materials, pending final disposal. If the ashes are disposed of by burial in soil or otherwise locally dispersed, they should be retained in the closed container until all cinders have been thoroughly cooled. Other waste shall not be placed in this container.

## Cleaning:

The stove should be shut-down and thoroughly cleaned after each ton of pellets consumed. The cleaner the stove, the more efficient it will be.

**Note:** Fuel with higher ash and/or moisture content will require more frequent cleanings.

1. Shut down the stove and **disconnect power cord** to insure that all motors are stopped.
2. Clean heat exchanger with scraper as shown in Figure 27.
3. Brush or scrape the inside of the stove to remove fly ash.
4. Scrape burnpot with flat end of scraper provided with the stove. Inspect the holes on the burnpot surface. See Figure 33.
5. Open burn pot clean-out. Clean fly ash from burn pot and replace cover.

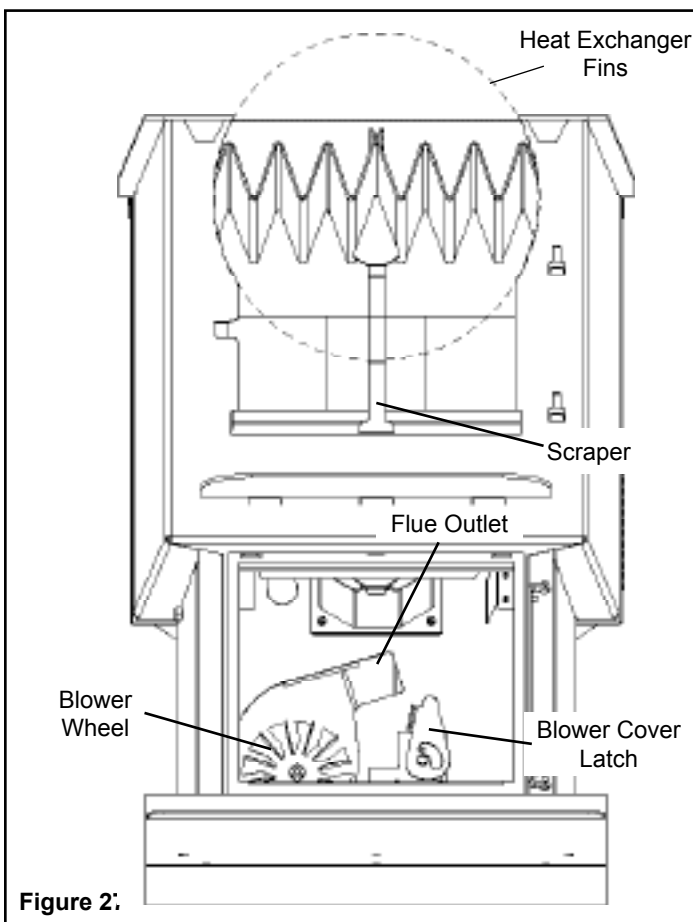

# Maintenance

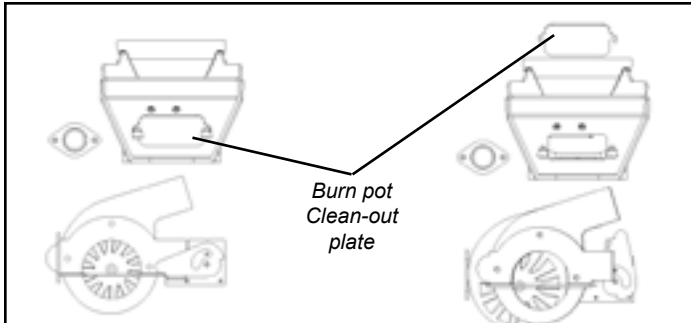
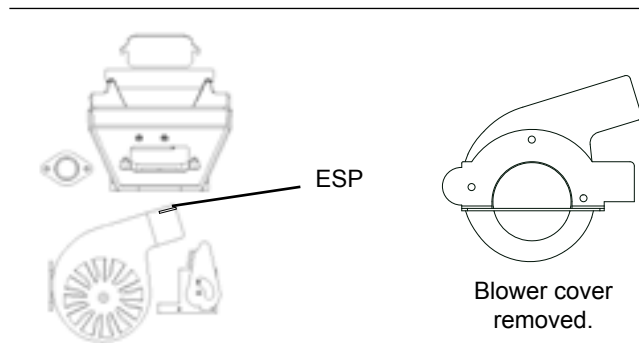

**Figure 28**

Latch "closed" with blower cover in place. Burn pot clean-out is closed.

**Figure 29**

Latch "open" with blower cover partly removed. Burn pot clean-out is open.



**Figure 30**

Exposed blower wheel and flue opening, NOTE: ESP is visible.

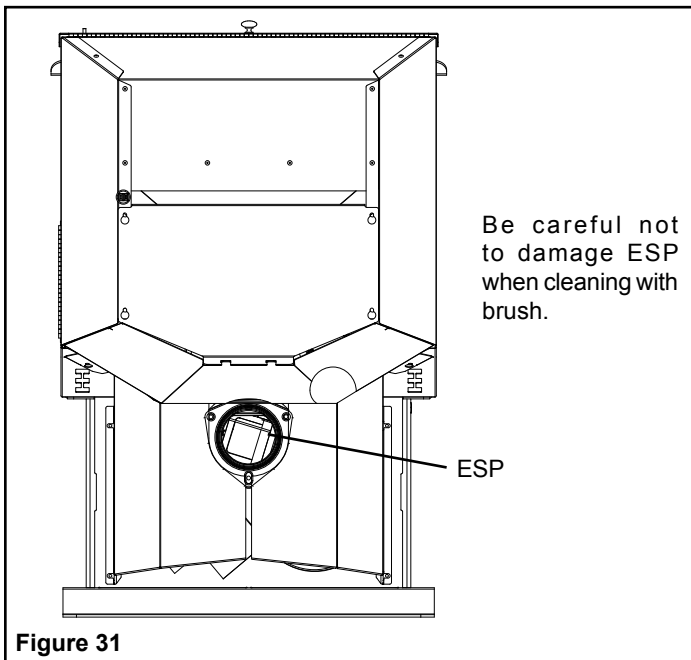

**Figure 31**

6. Remove the ash pan and properly dispose of the ashes.
7. Remove combustion blower cover by turning the blower cover latch vertical, see Figure 26. Sliding the cover out of the slot on the left. This will expose the combustion blower wheel and flue outlet, Figure 27.
8. Clean the combustion blower wheel with a brush and a vacuum cleaner. Note: Do not use a household vacuum to clean the stove. We recommend that you use a shop vacuum that is equipped with a fine dust filter called a HEPA filter or a vacuum specially made for ashes and soot. **Using a vacuum which is not equipped with a fine dust filter may clog and disperse fly ash and soot into the room.**

**NOTE: THE STOVE MUST BE COMPLETELY OUT BEFORE YOU VACUUM THE STOVE. LIVE PELLETS, IF SUCKED INTO THE VACUUM WILL LIGHT THE VACUUM ON FIRE AND MAY ULTIMATELY CAUSE A HOUSE FIRE.**

9. Use a brush to clean the flue, being careful not to damage the ESP, see Figure 30. The flue goes straight through into the vent pipe (Figure 27) therefore, the vent pipe can also be cleaned, to some extent, through the flue outlet.
10. Reinstall the blower cover and close the latch.
11. Slide the ash pan into stove and latch the door.

## Soot and Fly Ash

**Formation and Need for Removal** - The products of combustion will contain small particles of flyash. The flyash will collect in the exhaust venting system and restrict the flow of the flue gases. Incomplete combustion, such as occurs during startup, shutdown, or incorrect operation of the room heater will lead to some soot formation which will collect in the exhaust venting system. **The exhaust venting system should be inspected at least once every year to determine if cleaning is necessary.**

Removing fly ash and soot improves efficiency and insures that the flue venting passageway is clear and unobstructed. The stove should be cleaned after each ton of pellets (50 bags) and the venting system inspected and cleaned after each heating season.

# Burn Pot Maintenance

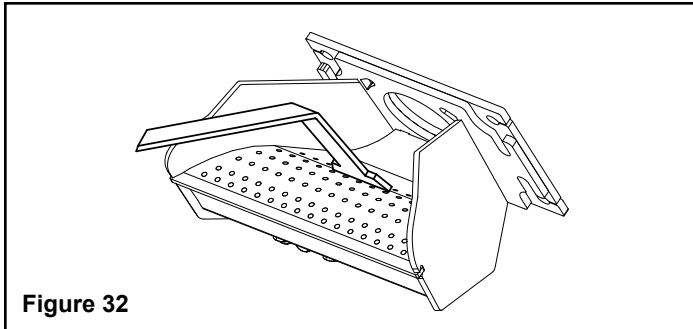

Figure 32

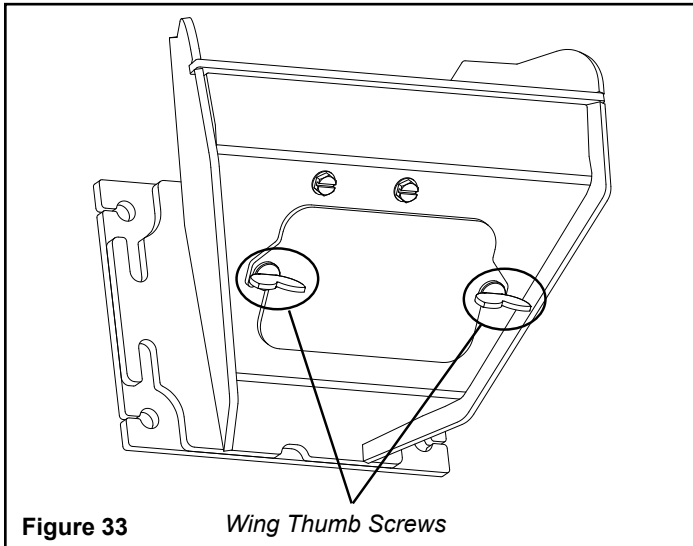

Figure 33

Wing Thumb Screws

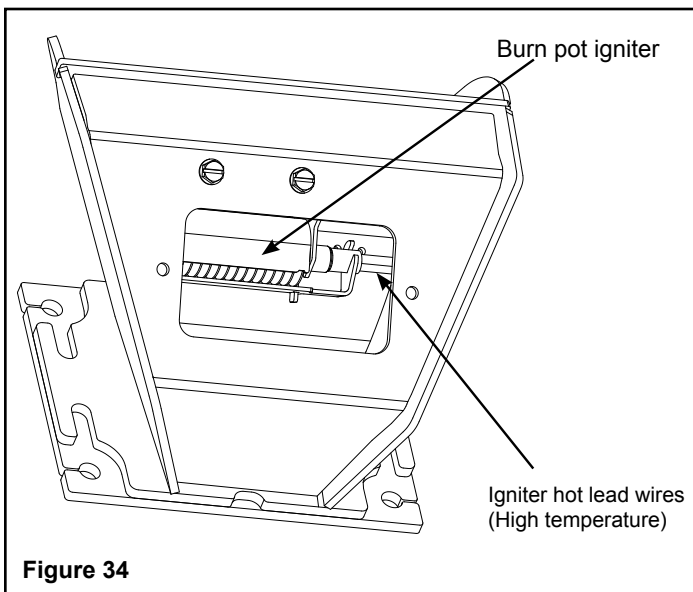

Figure 34

Viewed from below through the ash pan opening.

## **Burn Pot Cleaning and Maintenance**

1. Scrape the top holed surface and sides of the burn pot. (Figure 32) It is not necessary to completely remove all material from the burn pot. The excess will be pushed out during the next use.



**DANGER**

**Disconnect electrical power to the unit before removing cover.**

2. Loosen the (2) wing thumb screws on the lower front angle of the burn pot. (Figure 33)
3. Lift off the clean-out cover (Figure 34) to open the bottom clean-out chamber.
4. Clean ash buildup from inside the chamber while cover is off. Use the scraper to tap on the top front edge of the burn pot. This will help knock pieces of ash, loosened by the scraping process, down through the holes. It also helps knock scale off of the igniter element. (Figure 34)

## **Figure 34**

The igniter is made to be removable for service by insulated male/female wire connectors. These connections between the hot leads (the wires inside the burn pot) and the cold leads (the wires from the control board) are always pulled to the rear of the feeder body. **(Not coiled inside the burn pot.)**

It is very important that these connections are to the inside rear of the feeder body. Also, the extra wire of the igniter wire service loop must be pulled out through the rear of the feeder and tied up so that it will not be damaged by any moving parts.



**WARNING**

**Use caution when cleaning burn pot clean-out chamber. Do not damage the high temperature igniter wires.**

**Note: The hot lead/cold lead connection must always be pulled to the rear of the feeder body before operation.**



# Cleaning the Feeder Body

Pellet fines may accumulate in the feeder body over a period of time; therefore, a yearly inspection and cleaning of this area must be performed.

To clean out fines:

1. Remove the rear cover panels Figure 35.



**DANGER**

**Disconnect electrical power to the unit before removing cover.**

2. Remove wing nut and feeder cover on the side of the feeder.
3. Use a vacuum cleaner to remove all fines.
4. Reinstall feed cover, wing nut, and rear cover panels.

**NOTE:** Cover replacement is crucial for proper operation of the stove. Make sure cover is sealed properly.

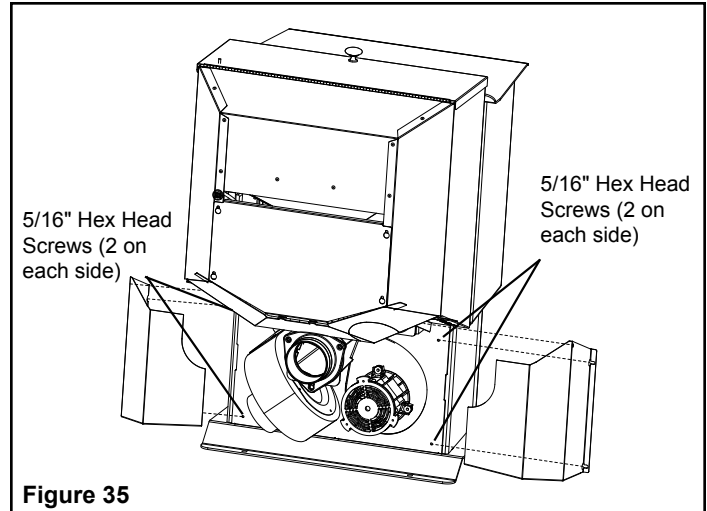
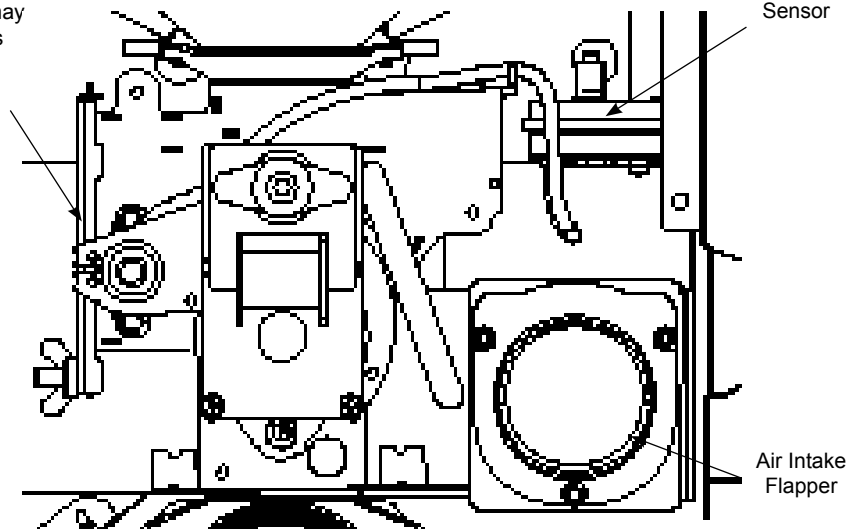

Figure 35

Pellet Fines may build up in this area



## Safety Features

The low draft sensor which is a vacuum differential switch, monitors the negative pressure (draft) in the firebox through a port on the rear of the feeder. Poor draft will result in an interruption of power to the feeder motor. Poor draft can be caused by blockage in the exhaust, excessive build-up on the combustion blower fan blades, a failed combustion blower, or a door or other opening to the firebox not sealed properly. The circuit board is monitoring the position of this switch. During a feed cycle, if this switch were to open, the feed motor light on the control will stay illuminated with the power being interrupted by the switch. If the switch opens when the cycle is at rest, the power light for the feed motor will not illuminate. Be sure all doors, including the hopper lid, are securely closed when operating the appliance.

# Troubleshooting

## STOVE DOES NOT FEED

1. No fuel in hopper.
2. Firebox draft may be too low for sensing switch in feeder circuit to operate. **Check for closed doors**, loose or missing gasket on doors or hopper lid.
3. Feed motor will not run until the ESP control senses a certain temperature. Maybe you did not put enough fuel or starting gel in the burn pot before manually lighting the fire.
4. Restriction in the hopper or feeder. Remove all fuel and examine. Clear the obstruction.
5. Feed motor has failed.

## PARTIALLY BURNED PELLETS

1. Feed rate too high.
2. Poor air to fuel mixture. (Check burn pot clean-out cover and air intake).
3. Burn pot or heat exchanger tubes may need to be cleaned.
4. Combination of all the above.
5. **#6 status blink**: A 6 blink control board status indication is caused by poor or incomplete combustion. The circuit board has the ability to track the combustion through feed settings and ESP temperatures. When the control board has calculated poor or incomplete combustion, it will shut down the unit as a safety feature. (Poor or incomplete combustion is a contributor of creosote which may cause a chimney fire)

### A 6 blink status may be caused by several things:

1. Blocked or partially blocked flue.
2. Blocked or partially blocked inlet air.
  - a. Backdraft damper on the inlet pipe may be stuck closed.
  - b. If outside air is installed, the Termination Cap may be blocked.
3. The air chamber under the burnpot may be filled with fines and small bits of ash.
4. The holes in the burnpot may be getting filled with ash or carbon buildup.
5. Combustion blower fan blades may need cleaned.
6. Fuel restrictions as noted above.

## SMOKE SMELL

Seal the vent pipe joints and connection to stove with silicone. The exhaust vent is the only part of the system that is under positive pressure.

### FIRE HAS GONE OUT- Check for status light.

1. No fuel in hopper.
2. Draft is too low, blocked flue.
3. Something is restricting fuel flow.
4. Hopper lid not closed properly.
5. Feed motor or combustion blower has failed.

## SMOKE IS VISIBLE COMING OUT OF VENT

1. Air-fuel ratio is too rich.
  - a. Feed rate too high.
  - b. Draft too low caused by a gasket leak.

## LOW HEAT OUTPUT

1. Feed rate too low
2. Draft too low because of gasket leak.
3. Poor quality or damp pellets
4. Combination of 1 and 2.

---

## Helpful Hints

### Cleaning Burn Pot

Whenever your stove is not burning, take the opportunity to scrape the burn pot to remove carbon buildup. A vacuum cleaner is handy to remove the residue. **Be sure the stove is cold if you use a vacuum.**

Carbon buildup can be scraped loose with the fire burning using the special tool provided with your stove. Scrape the floor and sides of the burn pot. The carbon will be pushed out by the incoming fuel. Always wear gloves to do this.

### Removing Ashes

Turn the Temp Dial to number 1 approximately 30 minutes before removing ashes. This will result in a cooler stove and ash pan.

### Curing Paint

You may notice some smoke and odor during the first firing of the appliance. This is likely part of the paint curing process, and will diminish with time. Consider keeping a window open during the first hour of operation, to remove any associated odors.

**Keep the stove free of dust and dirt, especially around the motors and circuit board.**

---

## Fuel

Pellet fuels are put into 3 categories in terms of ash content. Premium at 1% or less, Standard at 3% or less and all others at 3% or more.

The P61A is capable of burning all 3 categories of pellets, and up to a 50% mixture with shelled corn, see next page for special instructions.

It should be noted, that higher ash content will require more frequent ash removal, scraping of the burn pot, and may provide less BTU's per pound.

The moisture content of pellets must not exceed 8%, corn 15%. Higher moisture will rob BTU's and may not burn properly.

Fuel should be stored in a dry area, outside of the stove's installation clearance area and outside of the space required for charging and ash removal. See Page 7.

# Fuel Specifications

## Fuel and Fuel Storage

Pellet fuel quality can fluctuate from manufacturer to manufacturer, and even from bag to bag. Hearth & Home Technologies recommends using only fuel that is certified by the Pellet Fuels Institute (PFI).

### Fuel Material

- Made from sawdust and/or other wood by-products
- Shelled field corn (when mixed with wood pellets)
- Source material typically determines ash content

### Higher Ash Content Material

- Hardwoods with high mineral content
- Bark and leaves as source material
- "Standard" grade pellets, corn and other biomass

### Lower Ash Content Material

- Softwood; pine, fir, etc.
- Materials with lower mineral content
- "Premium" grade pellets

### Shelled field corn

- Must be 15% moisture content or less
- Must be clean and free of debris
- Must be mixed with wood pellets. (Up to 50%)
- Stalk parts, excessive fines and cob remnants may cause feed system jams or blockage

**CAUTION! Do not burn fuel that contains an additive; (such as soybean oil)**

- May cause hopper fire
- Damage to product may result

Read the list of ingredients on the packaging. If you are buying field corn, the only ingredient listed should be field corn.

**WARNING! Risk of Chemical Poisoning!**

Do **NOT** burn treated seed corn

- Chemical pesticides are harmful or fatal if swallowed
- Burning treated seed corn will void the product warranty

### Clinkers

Minerals and other non-combustible materials, like sand, will turn into a hard glass-like substance when heated. Trees from different areas will vary in mineral content. For this reason, some fuels will produce more clinkers than others.

### Moisture

Always burn dry fuel. Burning fuel with high moisture content takes energy to dry and tends to cool the appliance thus, robbing heat from your home. Damp pellet fuel could turn back into sawdust which does not flow properly through the feed system.

### Size

- Pellets are either 1/4 inch or 5/16 inch (6-8mm) in diameter
- Length should be no more than 1-1/2 inches (38mm)
- Pellet length can vary from lot to lot from the same manufacturer

### Performance

- Higher ash content requires more frequent maintenance.
- "Premium" grade pellets will produce the highest heat output.
- Burning pellets longer than 1-1/2 inches (38mm) can cause inconsistent feeding and/or ignition.

We recommend that you buy fuel in multi-ton lots whenever possible. However, we do recommend trying different brands prior to purchasing multi-ton lots, to ensure your satisfaction.

**CAUTION!** Attempting to burn fuels such as charcoal has the potential of generating Carbon Monoxide which is DEADLY. Never burn fuels other than those listed on the appliance safety label.

When changing from wood pellets to a corn/pellet mixture, the Feed limit will likely need adjusted to a lower setting. When under maximum demand, ensure there is no unburned fuel being pushed into the ash pan.

### Storage

- Wood pellets should be left in their original sealed bag until ready to use, to prevent moisture.
- Shelled corn should be stored in a tightly sealed container to prevent moisture and to deter pests
- Do not store fuel within the specified clearance areas, or in a location that will interfere with routine cleaning and maintenance procedures.

## CAUTION

Tested and approved for use with wood pellets and a mixture of shelled field corn and wood pellets ONLY. Burning of any other fuel will void your warranty.

## NOTICE

Hearth & Home Technologies is not responsible for stove performance or extra maintenance required as a result of using fuel with higher ash or mineral content.

## Addendum for Burning Corn and Pellet Fuel Mixture

Harman pellet burning, free-standing stoves and inserts have been tested to ASTM E1509 for burning shelled corn in a mixture with wood pellets. The listing approves up to a 50% corn and 50% pellet mixture. Different mixtures of corn will have distinctively different burn characteristics depending upon moisture content and variety. The operator should closely monitor the stove's operation when burning a new corn/pellet mixture or a different variety of corn, and make any necessary adjustments to feed rate. Since corn is typically higher in ash and moisture content, cleaning and ash removal will be needed more frequently.

### Operation in Stove Temp mode

Set feed adjuster to # 3. Set temperature knob to #3, Turn mode selector knob onto "Stove Temp" mode. After the fire has lit, watch that the fuel does not feed too fast that it pushes the red glowing fuel bed off of the burn pot grate. If it does, lower the feed adjuster setting or use a lower percentage of corn in the mixture. After the stove has burned for 10 minutes and the entire fuel bed is burning, the feed adjuster and temperature knobs may be adjusted for higher heat output if desired. Maximum feed has been reached when the fire bed is about 1/2 to 1 inch from the end of the burn pot. Settings will vary with different types, moisture levels and mix ratios of corn. If you are having difficulty burning a 50% corn / 50% wood pellet mixture, try a lower percentage of corn.

### Operation in Room Temp mode

Set feed adjuster to # 2 or # 3. Set temperature knob to desired amount. Turn mode selector knob onto "Room Temp" mode. After the fire has lit, watch that the fuel does not feed too fast that it pushes the red glowing fuel bed off of the burn pot grate. After the stove has burned for 10 minutes and the entire fuel bed is burning, the feed adjuster may be set to a higher output level if desired. Maximum feed has been reached when the fire bed is about 1/2 to 1 inch from the end of the burn pot. It is recommended that after burning at the desired settings, turn the stove off and allow it to cool, then turn it back on in "Room Temp" mode and watch the stove restart and verify correct operation. Settings will vary with different types, moisture levels and mix ratios of corn. If you are having difficulty burning a 50% corn 50% wood pellet mixture, try a lower percentage of corn.

### Changes to Maintenance Schedule

Wood pellets average around 6% moisture content or less. Corn will be 14 or 15% moisture. With more moisture in the fuel, more maintenance will be incurred. Burn pot scraping may need to be done once per day. The ash pan will fill more quickly and may need emptied weekly. Most importantly, remove the burn pot cleanout cover weekly to clean the air passage and the igniter element. Excessive buildup on the igniter may lead to shortened igniter life.

**Venting Consideration:** Check with your venting manufacturer regarding possible exclusions when a mixture of corn and pellets is burned.

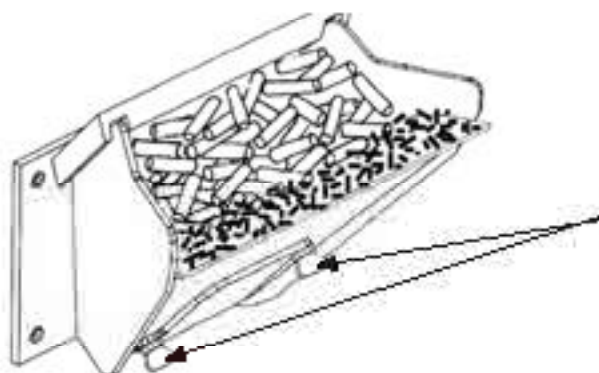

Loosen these two wing screws for access to clean the air passage and igniter.

\* For P38+ model, follow Stove Temp instructions. Keep feed rate on #3 or above when using a wall thermostat.

## Addendum

### Minimizing Smoke During Loss of Power Using Battery Back-up

Harman® strongly recommends installing battery back-up to minimize entry of smoke into the room in the event of power loss.

Your pellet/biomass burning appliance relies on a combustion blower to remove exhaust. A power failure will cause the combustion blower to stop. This may lead to exhaust seeping into the room. Vertical rise in the venting may provide natural draft. It is, however, no guarantee against leakage.

**There are two Harman® approved battery back-up options for your appliance:**

**Uninterruptible Power Supply (UPS)** UPS battery back-ups are available online or at computer and office equipment stores. Your Harman® appliance with Rev E or later software available beginning in November 2010 may be plugged directly into a Harman® approved UPS:

- The APC (American Power Conversion) model #BE750G and the TrippLite model INTERNET750U are tested and approved. Other brands or models may not be compatible.

When power is lost, a fully charged UPS will power a safe, combustion blower only shut-down. Your appliance will pulse the blower every few seconds to clear exhaust until the fire is out. **NOTE: The UPS provides safe shut-down only. It is not intended for continued operation.**

Your appliance will recognize when power is restored. What happens depends on ESP temperature and whether it is equipped with automatic ignition:

- In **“Automatic” setting**, units equipped with automatic ignition will respond to the set point and ESP temperature and resume normal operation.
- In **“Manual” setting** or for units without automatic ignition:
  - If the ESP is cool, the appliance will remain shut down.
  - If the fire is out and the ESP is still warm, the feeder may restart. Since the fire is out, the ESP temperature will not rise. The unit will then shut-down, and may flash a six-blink status error. (See ESP error codes)
  - If the fire is still burning, it will resume normal operation.

Contact your dealer if you have questions about UPS compatibility with your appliance.

**Harman® Surefire 512H Battery Back-up** The 512H connects to a 12 volt deep cycle battery that will run your appliance for up to eight (8) hours. It includes a trickle charge feature that keeps your battery charged when power is available. **NOTE: If the power is out for longer than battery life, smoke leakage may still occur unless your stove has been safely shut down.**

**CAUTION! Always keep appliance doors and hopper lid closed and latched during operation and during power failures to minimize risk of smoke or burn-back.**

**CAUTION! Use only Harman® approved battery back-up devices. Other products may not operate properly, can create unsafe conditions or damage your appliance.**

# Wiring Diagram

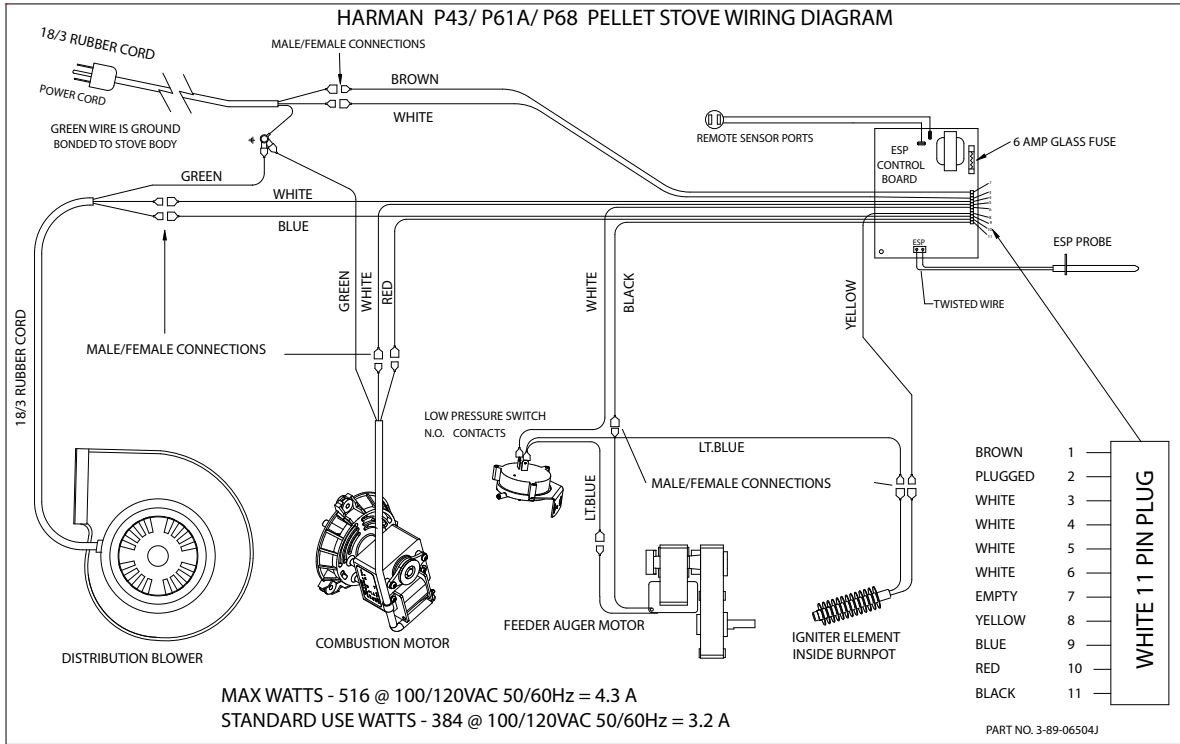

# Specifications

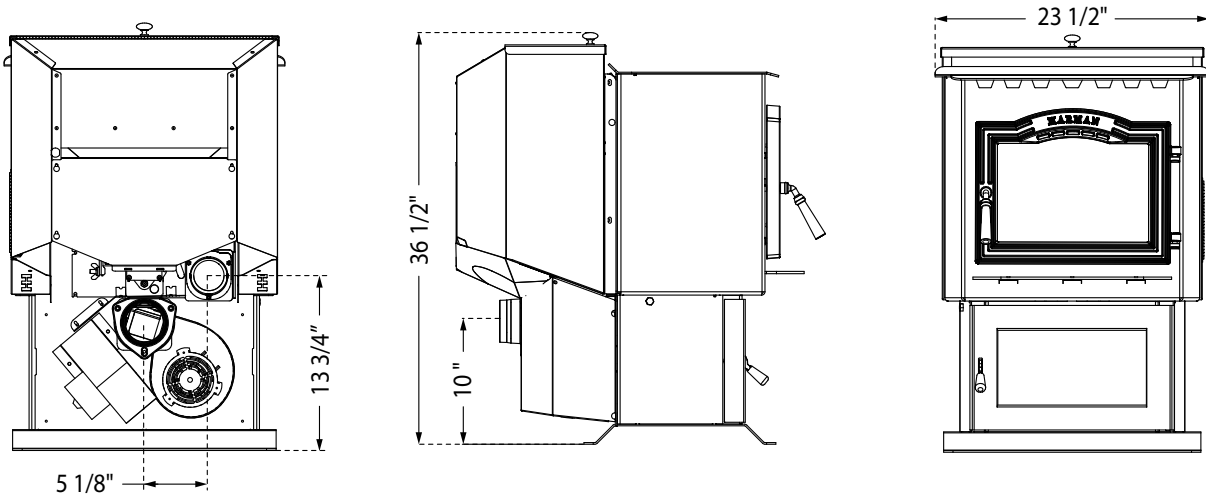

<b>Weight</b>	<b>249 lbs.</b>
<b>Blower</b>	<b>135 cfm</b>
<b>Feed Rate</b>	<b>.75 to 7.5 lbs. per hr.</b>
<b>Hopper Capacity</b>	<b>72 lbs.</b>
<b>Fuel</b>	<b>Wood Pellets- Corn/Pellet Mixture</b>
<b>Flue Size</b>	<b>3 inch</b>
<b>Outside Air Size</b>	<b>3"</b>
<b>Fuse Rating</b>	<b>6 amp</b>

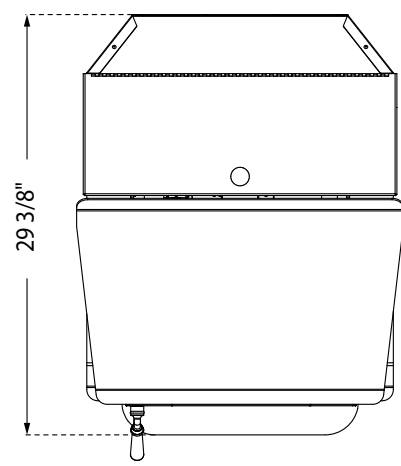

## Hearth & Home Technologies LIMITED LIFETIME WARRANTY

Hearth & Home Technologies, on behalf of its hearth brands ("HHT"), extends the following warranty for HHT gas, wood, pellet, coal and electric hearth appliances that are purchased from an HHT authorized dealer.

### **WARRANTY COVERAGE:**

HHT warrants to the original owner of the HHT appliance at the site of installation, and to any transferee taking ownership of the appliance at the site of installation within two years following the date of original purchase, that the HHT appliance will be free from defects in materials and workmanship at the time of manufacture. After installation, if covered components manufactured by HHT are found to be defective in materials or workmanship during the applicable warranty period, HHT will, at its option, repair or replace the covered components. HHT, at its own discretion, may fully discharge all of its obligations under such warranties by replacing the product itself or refunding the verified purchase price of the product itself. The maximum amount recoverable under this warranty is limited to the purchase price of the product. This warranty is subject to conditions, exclusions and limitations as described below.

### **WARRANTY PERIOD:**

Warranty coverage begins on the date of original purchase. In the case of new home construction, warranty coverage begins on the date of first occupancy of the dwelling or six months after the sale of the product by an independent, authorized HHT dealer/ distributor, whichever occurs earlier. The warranty shall commence no later than 24 months following the date of product shipment from HHT, regardless of the installation or occupancy date. The warranty period for parts and labor for covered components is produced in the following table.

The term "Limited Lifetime" in the table below is defined as: 20 years from the beginning date of warranty coverage for gas appliances, and 10 years from the beginning date of warranty coverage for wood, pellet, and coal appliances. These time periods reflect the minimum expected useful lives of the designated components under normal operating conditions.

Warranty Period		HHT Manufactured Appliances and Venting							Components Covered
Parts	Labor	Gas	Wood	Pellet	EPA Wood	Coal	Electric	Venting	
1 Year		X	X	X	X	X	X	X	All parts and material except as covered by Conditions, Exclusions, and Limitations listed
2 years				X	X	X			Igniters, electronic components, and glass
		X	X	X	X	X			Factory-installed blowers
				X					Molded refractory panels
3 years				X					Firepots and burnpots
5 years	1 year			X	X				Castings and baffles
7 years	3 years		X	X	X				Manifold tubes, HHT chimney and termination
10 years	1 year	X							Burners, logs and refractory
Limited Lifetime	3 years	X	X	X	X	X			Firebox and heat exchanger
90 Days		X	X	X	X	X	X	X	All replacement parts beyond warranty period

See conditions, exclusions, and limitations on next page.

## **WARRANTY CONDITIONS:**

- This warranty only covers HHT appliances that are purchased through an HHT authorized dealer or distributor. A list of HHT authorized dealers is available on the HHT branded websites.
- This warranty is only valid while the HHT appliance remains at the site of original installation.
- This warranty is only valid in the country in which the HHT authorized dealer or distributor that sold the appliance resides.
- Contact your installing dealer for warranty service. If the installing dealer is unable to provide necessary parts, contact the nearest HHT authorized dealer or supplier. Additional service fees may apply if you are seeking warranty service from a dealer other than the dealer from whom you originally purchased the product.
- Check with your dealer in advance for any costs to you when arranging a warranty call. Travel and shipping charges for parts are not covered by this warranty.

## **WARRANTY EXCLUSIONS:**

This warranty does not cover the following:

- Changes in surface finishes as a result of normal use. As a heating appliance, some changes in color of interior and exterior surface finishes may occur. This is not a flaw and is not covered under warranty.
- Damage to printed, plated, or enameled surfaces caused by fingerprints, accidents, misuse, scratches, melted items, or other external sources and residues left on the plated surfaces from the use of abrasive cleaners or polishes.
- Repair or replacement of parts that are subject to normal wear and tear during the warranty period. These parts include: paint, wood, pellet and coal gaskets, firebricks, grates, flame guides, batteries and the discoloration of glass.
- Minor expansion, contraction, or movement of certain parts causing noise. These conditions are normal and complaints related to this noise are not covered by this warranty.
- Damages resulting from: (1) failure to install, operate, or maintain the appliance in accordance with the installation instructions, operating instructions, and listing agent identification label furnished with the appliance; (2) failure to install the appliance in accordance with local building codes; (3) shipping or improper handling; (4) improper operation, abuse, misuse, continued operation with damaged, corroded or failed components, accident, or improperly/incorrectly performed repairs; (5) environmental conditions, inadequate ventilation, negative pressure, or drafting caused by tightly sealed constructions, insufficient make-up air supply, or handling devices such as exhaust fans or forced air furnaces or other such causes; (6) use of fuels other than those specified in the operating instructions; (7) installation or use of components not supplied with the appliance or any other components not expressly authorized and approved by HHT; (8) modification of the appliance not expressly authorized and approved by HHT in writing; and/or (9) interruptions or fluctuations of electrical power supply to the appliance.
- Non-HHT venting components, hearth components or other accessories used in conjunction with the appliance.
- Any part of a pre-existing fireplace system in which an insert or a decorative gas appliance is installed.
- HHT's obligation under this warranty does not extend to the appliance's capability to heat the desired space. Information is provided to assist the consumer and the dealer in selecting the proper appliance for the application. Consideration must be given to appliance location and configuration, environmental conditions, insulation and air tightness of the structure.

## **This warranty is void if:**

- The appliance has been over-fired or operated in atmospheres contaminated by chlorine, fluorine, or other damaging chemicals. Over-firing can be identified by, but not limited to, warped plates or tubes, rust colored cast iron, bubbling, cracking and discoloration of steel or enamel finishes.
- The appliance is subjected to prolonged periods of dampness or condensation.
- There is any damage to the appliance or other components due to water or weather damage which is the result of, but not limited to, improper chimney or venting installation.

## **LIMITATIONS OF LIABILITY:**

- The owner's exclusive remedy and HHT's sole obligation under this warranty, under any other warranty, express or implied, or in contract, tort or otherwise, shall be limited to replacement, repair, or refund, as specified above. In no event will HHT be liable for any incidental or consequential damages caused by defects in the appliance. Some states do not allow exclusions or limitation of incidental or consequential damages, so these limitations may not apply to you. This warranty gives you specific rights; you may also have other rights, which vary from state to state. EXCEPT TO THE EXTENT PROVIDED BY LAW, HHT MAKES NO EXPRESS WARRANTIES OTHER THAN THE WARRANTY SPECIFIED HEREIN. THE DURATION OF ANY IMPLIED WARRANTY IS LIMITED TO DURATION OF THE EXPRESSED WARRANTY SPECIFIED ABOVE.









At Harman, we build each product to a standard, not a price. This powerful heating appliance boasts uncompromising attention to detail and helps preserve our planet by using environmentally responsible fuels.

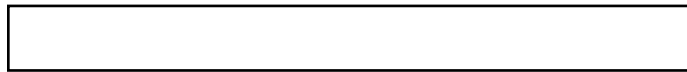

(Signature of Boxer)

Your premium quality hearth product designed and assembled by the experienced and skilled members at Harman in Halifax, PA, USA.

**HARMAN**<sup>®</sup>

**BUILT TO A STANDARD, NOT A PRICE**

Proudly Printed On 100% Recycled Paper

