

# **OWNERS MANUAL**

## **LIBERATOR ROCKET HEATER**

**Model: RMH-2**

**SAVE THIS MANUAL FOR FUTURE REFERENCE**

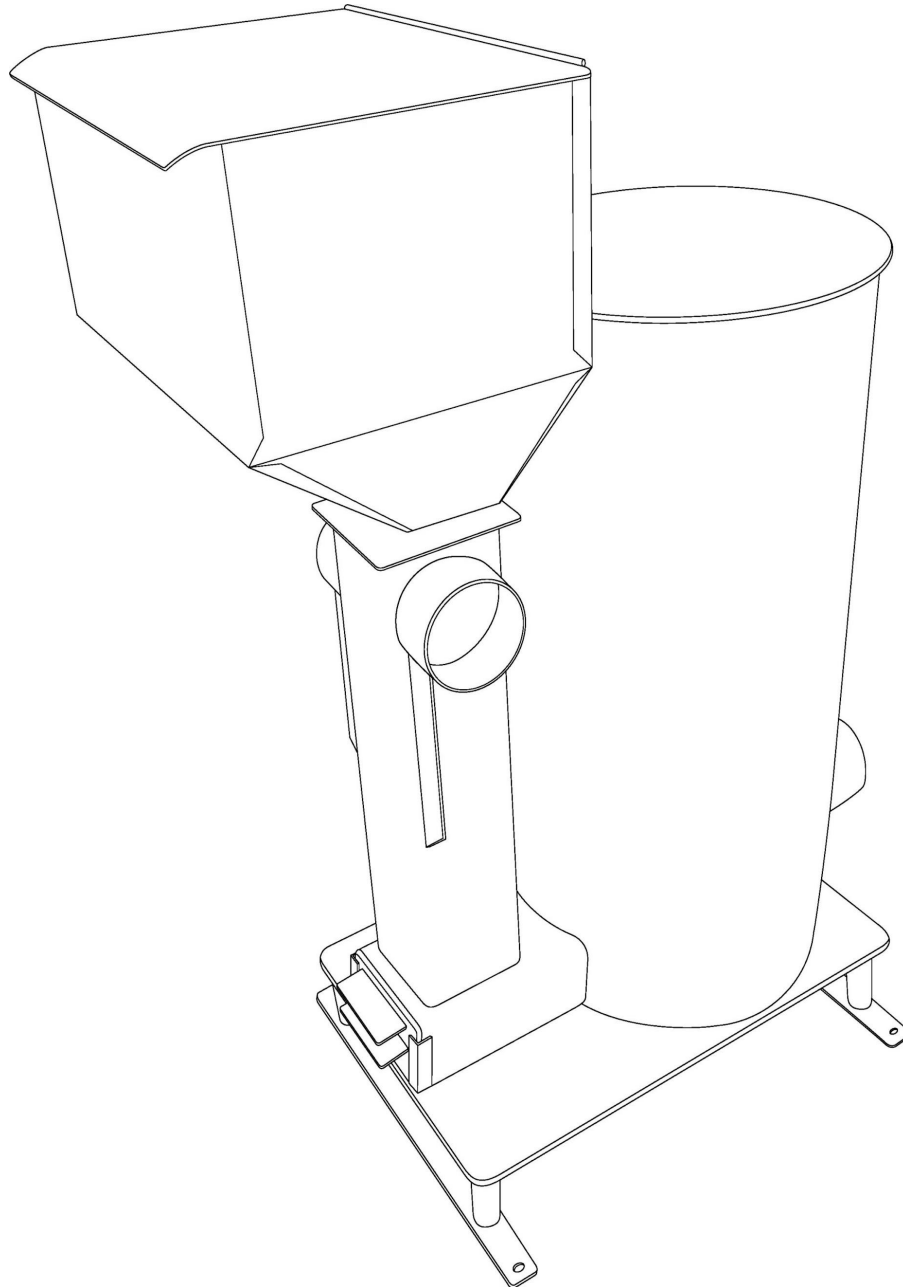

**ROCKETHEATER.COM**  
**139 Old Hwy 66, Bourbon MO 65441**  
**(573)-468-4043**

# Table of Contents

1. Cover, Page 1
2. Table of Contents, Specifications, and Shipping Dimensions, Page 2
3. Warranty, Page 3
4. Warnings, Pages 4 – 5
5. Clearances to Walls, Page 6
6. Installation to Masonry Chimney, Pages 6 – 9
7. Installation to Class A Chimney, Pages 10 – 11
8. Installation of Combustion Air Inlet, Page 12
9. Integration of Rocket Heater to Thermal Mass, Pages 13 – 14
10. Installation and Use of Chimney/Flue Damper, Page 15
11. Installation of the Pellet Hopper, Pages 16 – 17
12. Final Draft Inspection & Maintenance, Page 18
13. Parts Diagrams, Page 19
14. Operation as a Rocket Mass Heater, Page 20

## Specifications

Height: 36.5”

Depth: 26”

Width: 20”

Weight: 185 lbs.

## Shipping Dimensions (With Pellet Hopper)

Height: 56”

Length: 32”

Width: 24”

Weight: 265 lbs

# **Liberator Rocket Heater Warranty**

Liberator Rocket Heater warrants to the original consumer of the product the following:

**3 years parts (1 year Labor)**

-Fuel Feed Tube, Cooktop, Flue Collar Burn Chamber, Ash Cleanout and Door, Air intake Assembly

**1 year parts and Labor**

-Ceramic Tiles

**Conditions**

The warranty of the manufacturer extends only to the original consumer purchaser and is not transferable. Proof of purchase (date, bill of sale), model name and serial number must be supplied when making a warranty claim to Liberator Rocket Heater. This warranty covers brand new products only, which have not been altered, modified nor repaired since shipment from factory. This warranty applies to normal residential use only.

**Exclusions**

-Damages caused by misuse, abuse, improper installation, lack of maintenance, over firing, negligence, accident during transportation, power failures, downdrafts, or venting problems are not covered by this warranty.

-This warranty does not cover any scratch, corrosion, warping, or discoloration caused by over firing, abrasive or chemical cleaners.

-Any defect or damage caused by the use of unauthorized parts void this warranty.

-An authorized qualified technician must perform the installation in accordance with the instructions supplied with this product and all local and national building codes.

-Any service call related to an improper installation is not covered by this warranty.

The manufacturer may require that defective products be returned or that digital pictures be provided to support the claim. Returned products are to be shipped prepaid to the manufacturer or agent for investigation. If a product is found to be defective, the manufacturer will repair or replace (at the manufacturer's discretion) such defect.

The manufacturer may, at its discretion, fully discharge all obligations with respect to this warranty by refunding the wholesale price of any warranted but defective part(s). The manufacturer shall in no event be responsible for any special, indirect, consequential damages of any nature, which are in excess of the original purchase price of the product.

A one-time replacement limit applies to all parts benefiting from warranty coverage.

Thank you for your purchase of the Liberator Rocket Heater. As you may already know, the Rocket Heater is among the cleanest burning stoves available in the North American market, possessing a HHV ranging from 68.5% to 79.7%, an emissions output of 0.38 to 1.66 grams per hour of solid particulate, 0.02 to 0.37 grams per minute of CO, and combustion efficiency of up to 99.5%. As such, this heater is compliant to EPA 2020 NSPS standards. The tests were conducted by PFS Teco using pellet fuel in accordance with ASTM E2779 with Liberator RMH2 ATM single burn rate pellet heaters dated 09/09/2021 EPA OAQPS. According to independent testing from Aprovecho Research and PFS Teco, the heat output range varies from 27,000 BTU's to 33,000 BTU's per hour. This owners manual will assist you in the proper use, maintenance, installation, and safety precautions to undertake in the heater's operation and installation.

## **WARNING! READ ALL INSTRUCTIONS CAREFULLY BEFORE USING OR INSTALLING! SAFETY PRECAUTIONS!**

-Do not touch the appliance while it is hot, in operation or thereafter. Educate all children of the danger of high temperature appliances and maintain supervision of children at all times when children are in the same room as the appliance.

-As a stand alone Pellet Heater, this appliance is only suitable for burning fuel pellets. Never use flammable liquids, artificial logs containing any petroleum derived products of any kind, or any other fuels not covered in this manual at any time under any circumstances. Plastics, foam material, or any other material not mentioned are never to be used in any way as a fuel or for other purposes with this appliance. Do not burn garbage, lawn clipping or similar yard waste, materials containing plastic, waste petroleum products, paints or paint thinners, asphalt products, materials containing asbestos, construction or demolition debris, railroad ties or pressure treated lumber, manure or animal remains, salt water driftwood or other salt water saturated materials, unseasoned wood, or paper products such as cardboard, plywood, or particleboard. The prohibition of these materials does not prohibit the use of fire starters made from paper, cardboard, saw dust, wax, and similar. Burning prohibited materials may result in the release of toxic fumes or render the heater ineffective and cause smoke.

-Never use gasoline, gasoline-type lantern fuel, kerosene, charcoal lighter fluid or similar liquids to start or 'freshen up' a fire in this heater. Keep all such liquids well away from the heater while it is in use.

-The ash cleanout door must never be opened while in operation.

-Do not install in a sleeping room.

-Ashes must be disposed of only when completely cooled with absolutely no embers, cinders, or other signs of combustion in a metal airtight container and the closed container of ashes should be placed on a non combustible floor or on the ground well away from any combustible materials pending final disposal. If the ashes are to be disposed of by burial in soil or otherwise locally dispersed, they should be retained in the closed container until all cinders have thoroughly cooled.

-Always review the local, state, and federal laws before installing this appliance. If applicable in your area, contact your local building officials to obtain a permit and information on any installation restrictions and inspection requirements in your area. If you have insurance, notify your insurance company and provider.

-This appliance must be properly installed to reduce the chance of house fires. The installation instructions must be adhered to. Never use makeshift methods or materials to install this appliance. It is highly recommended that you hire or consult an accredited expert with experience in wood stoves in this appliance installation.

-This appliance must be connected to an approved or nationally recognized testing laboratory listed chimney or flue pipe specifically designed for wood burning/heating and high temperatures, with a flue no less than 6" inches in diameter. This heater requires an approved masonry or UL or other NRTL listed residential type and building heating appliance chimney. Use a 6" inch diameter chimney that is high enough to give a good draft.

-Creosote – Formation and Need for Removal. When wood burns slowly, it produces tar and other organic vapors, which combine with expelled moisture to form creosote. The creosote vapors condense in the relatively cool chimney flue of a slow-burning fire. As a result, creosote residue accumulates on the flue lining. When ignited this creosote makes an extremely hot fire. The chimney connector and chimney should be inspected at least once every two months during the heating season to determine if a creosote buildup has occurred. If creosote has accumulated it should be removed to reduce the risk of a chimney fire.

-Never vent to another room or inside a building.

-The special paints used on your heater may give off some smoke and fumes that are not safe to breathe while they are curing during the first few fires. If possible, open windows to vent out the fumes for the first three (3) hours of operation, or until the paint is cured.

-Never place clothing or other flammable material on or near this appliance.

-This heater must be connected to an appropriate chimney and vented outside.

-Never overfire this appliance. If any portion of this appliance or the chimney flue glow, and/or reach the point of incandescence, or exceed 800 degrees Fahrenheit (427 degrees Celsius) this appliance is being overfired and action must be taken to eliminate this effect. Generally, if overfiring is occurring the best course of action is to stop feeding fuel in this appliance and turn the flue damper to reduce draft.

-Never connect this unit to a chimney flue serving another appliance.

-Save this manual for future reference.

-To prevent injury, do not allow anyone to use this heater who is unfamiliar with the correct operation of the heater.

-For your safety, we strongly recommend installing both smoke and carbon monoxide detectors throughout the house or structure this appliance is installed in, particularly in the room the heater is installed in, pellet fuel bulk storage areas, and sheds containing flammable materials/fuels. Carbon Monoxide detectors usually necessitate installation at floor level, as CO is denser than ambient atmospheric air.

-Do not connect a wood burning heater to a Type B gas vent. Doing so is not safe and is prohibited by the National Fire Protection Association Code.

-Liberator LLC grants no warranties, implied or stated, for the installation or maintenance of your appliance, and assumes no responsibility for any consequential damage. Safety, damage to property, injury, et cetera, is the sole responsibility of the owner(s) of this appliance.

-This wood heater has a manufacturer-set minimum low burn rate that must not be altered. It is against federal regulation to alter this setting or otherwise operate this wood heater in a manner inconsistent with operating instructions in this manual.

-Attempts to achieve heat output rates that exceed heater design specifications can result in permanent damage to the heater.

-This wood heater needs periodic inspection and repair for proper operation. It is against federal regulations to operate this wood heater in a manner inconsistent with operating instructions in this manual.

**-You are the only one who is responsible for your safety, your property, and your actions-**

**-Caveat Emptor-**

**This heater is tested and listed to UL-1482, ULC-S627, and ASTM E1509**

**by Guardian Fire Testing Laboratories.**

**It is a violation of US Federal Code to burn wood in this heater as a standalone wood stove.**

**SAFETY NOTICE: IF THIS HEATER IS NOT PROPERLY INSTALLED, A HOUSE FIRE MAY RESULT. FOR YOUR SAFETY, FOLLOW THE INSTALLATION DIRECTIONS. CONTACT LOCAL BUILDING OR FIRE OFFICIALS ABOUT RESTRICTIONS AND INSTALLATION INSPECTION REQUIREMENTS IN YOUR AREA.**

## Clearances to Walls

Place the heater on solid masonry or solid concrete. When the heater is used on a combustible floor, use an Underwriters Laboratory Listed or equivalent Type 2 floor protector. The floor protector must comply with NRTL Standards. The floor protector should extend at least 16" inches beyond the front of the cleanout door of the heater, 8" inches beyond each side of the door, and at least 6" inches past the back of the chimney pipe. In addition the floor protector should extend under and 2" inches beyond each side of the chimney connector. There must be at least 36" inches from the top of the stove to the ceiling.

1. Install a stovepipe and/or chimney if you do not have one. Only use a cleaned and inspected masonry chimney that is properly lined for wood burning appliances, or a UL or other NRTL Listed chimney designed for wood burning appliances.
2. Place the stove in accordance with the diagrams minimum clearances. Once the stove is connected to the flue pipe and chimney, mechanically lock all joints by using at least three (3) sheet metal screws at each joint. Always install the flue and chimney connectors with the crimped (smaller) end of the joints and elbows pointing down, toward the wood stoves exhaust collar. This to ensure that, in the event of excessive creosote buildup, that creosote will not run or flow onto the outside of the chimney or flue thus creating an external fire hazard.
3. Check the illustrations below for clearances of the heater to the walls. If you have a solid brick, solid stone, concrete or otherwise non-combustible inert wall, then you may place your heater as you wish regarding those surfaces and walls. However, if the wall in question is only faced with brick, stone, metal, and the like then you must consider them as combustible walls.

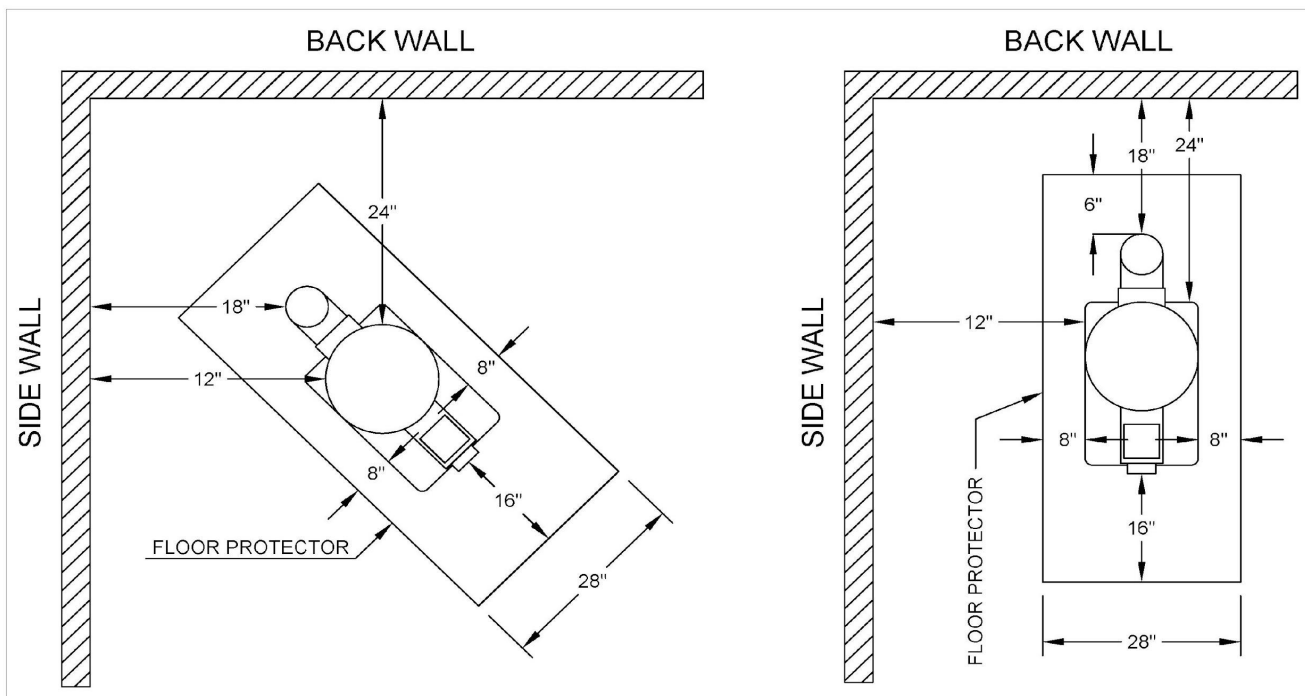

# Chimney Connection

## Masonry Chimney

The masonry chimney must comply with UL or equivalent NRTL and NFPA 211 standards and codes. Before using an existing masonry chimney, clean the chimney and inspect the flue liner to be absolutely sure it is safe to use.

## Rules For Connecting To A Masonry Chimney

1. Use a minimum of 3-1/2" inch brick masonry wall framed to a combustible wall. A fireclay liner (ASTM 135 or equivalent) having a 5/8" inch minimum wall thickness must be used and it must be at least 12" inches (1' foot) away from any material that could catch fire. The inside diameter of the fire clay liner shall be sized for the proper snug fit to a 6" inch diameter chimney connector pipe. The fireclay liner shall run to, but not beyond, the inner surface of the chimney flue and be firmly cemented in place.
2. Use a solid insulated listed factory built chimney length having an inside diameter of 6" inches and having 1" inch or more of solid insulation. There must be at least a 9" inch air space between the outer wall of the chimney length and any combustible materials. The inner end of the chimney length shall be flush with the inside of the masonry chimney flue which shall be sealed to the flue and to the brick masonry penetration with non water-soluble refractory cement. Flash sheet steel supports which are at least 24 gauge (0.025" inches) in thickness shall be securely fastened to wall surfaces on all sides. Fasteners between supports and the chimney length shall not penetrate the chimney liner.
3. Use a 10" inch diameter ventilated thimble made of at least 24 gauge (0.025" inch) steel having two (2) 1" inch air channels. The ventilated thimble must be separated from combustible materials by at least 6" inches of glass fiber insulation. The opening in the combustible wall shall be covered and the thimble supported with sheet steel supports which are at least 24 gauge (0.025" inch) in thickness. The sheet steel supports shall be securely fastened to wall surfaces on all sides and shall be sized to fit and hold the chimney section. Fasteners used to secure chimney sections shall not penetrate the chimney flue liner.
4. Use an 8" inch diameter solid insulated listed factory-built chimney length which has 1" inch or more solid insulation. The minimum length of the chimney section shall be 12" inches and will serve a pass through for the 6" inch diameter chimney connector. There must be at least a 12" inch air space between the outer wall and the chimney section and any combustible materials. The chimney section shall be concentric with and spaced 1" inch away from the chimney connector by means of sheet steel support plates on both ends of the chimney section. The opening in the combustible wall shall be covered and the chimney section supported on both sides with sheet metal supports which are at least 24 gauge (0.025" inches) in thickness. The sheet steel supports shall be securely fastened to wall surfaces on all sides and shall be sized to fit and hold the chimney section. Features used to secure chimney sections shall not penetrate chimney flue liner.
5. A UL or NRTL listed factory-built wall pass-through system may be purchased and installed according to the instruction supplied with it to provide a safe method of passing the chimney connector through a combustible wall for connection to a masonry chimney.

**Please See the Following Pages for Diagrammatic Details  
and Clearances for Masonry Chimney Installation**

# Flue Connection Through a Non-Combustible Wall

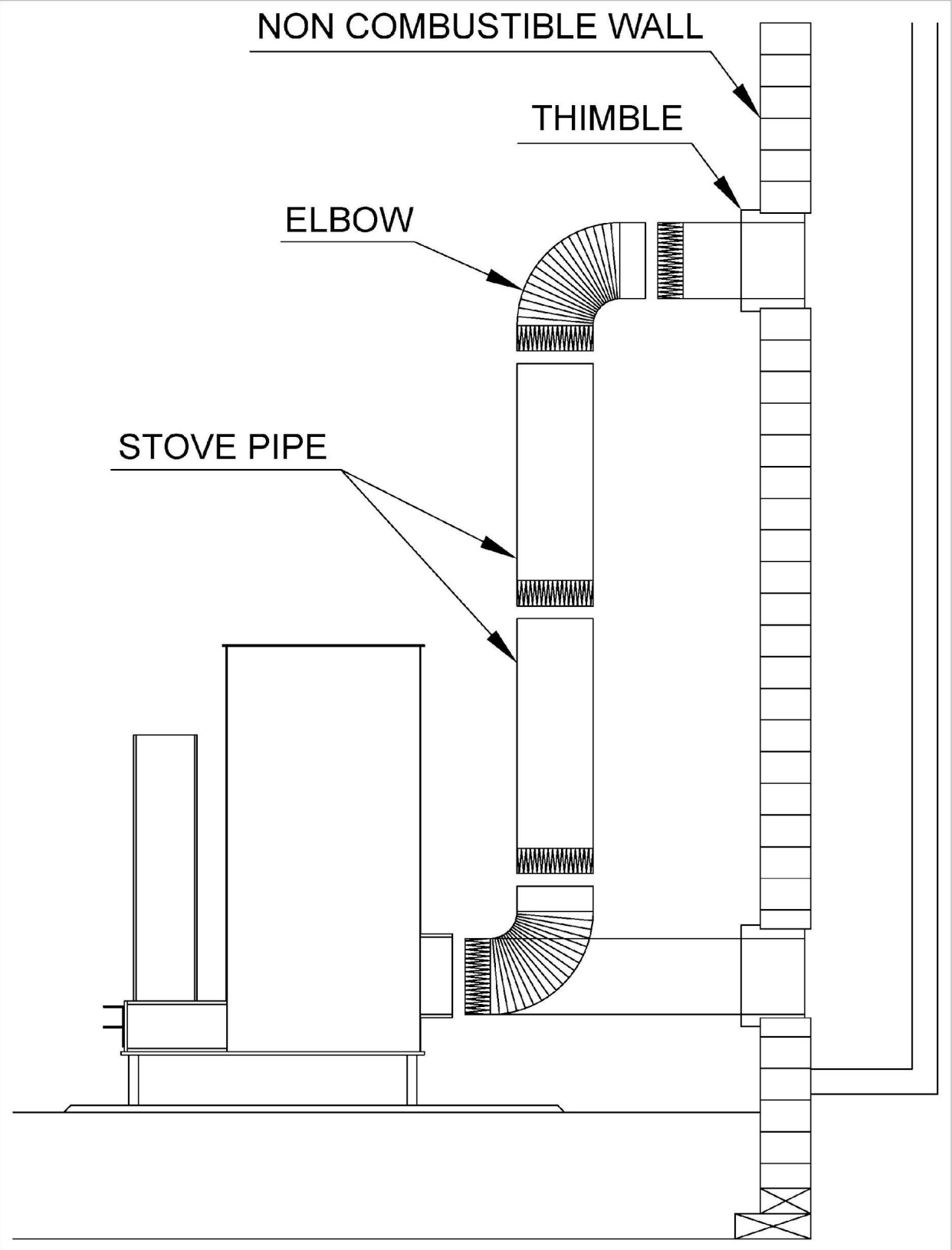



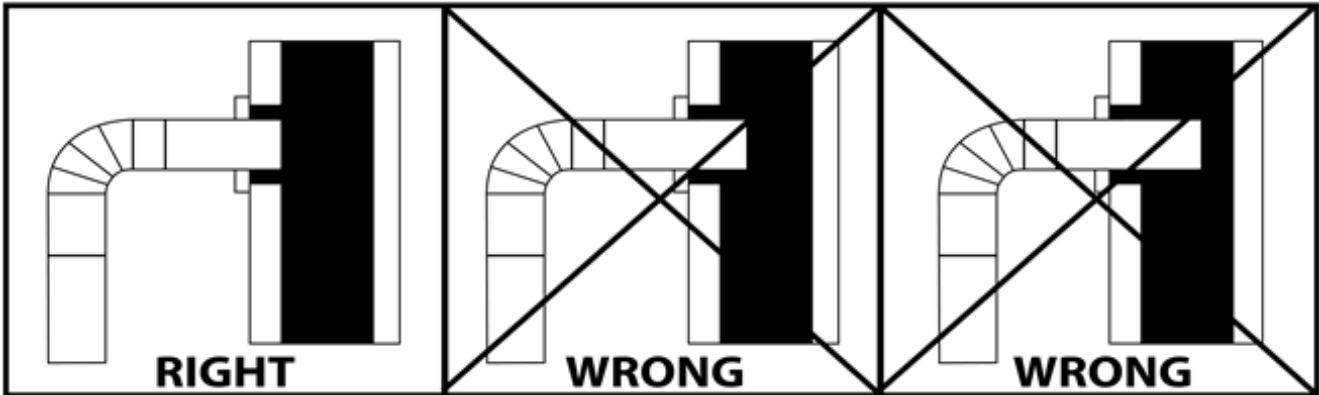
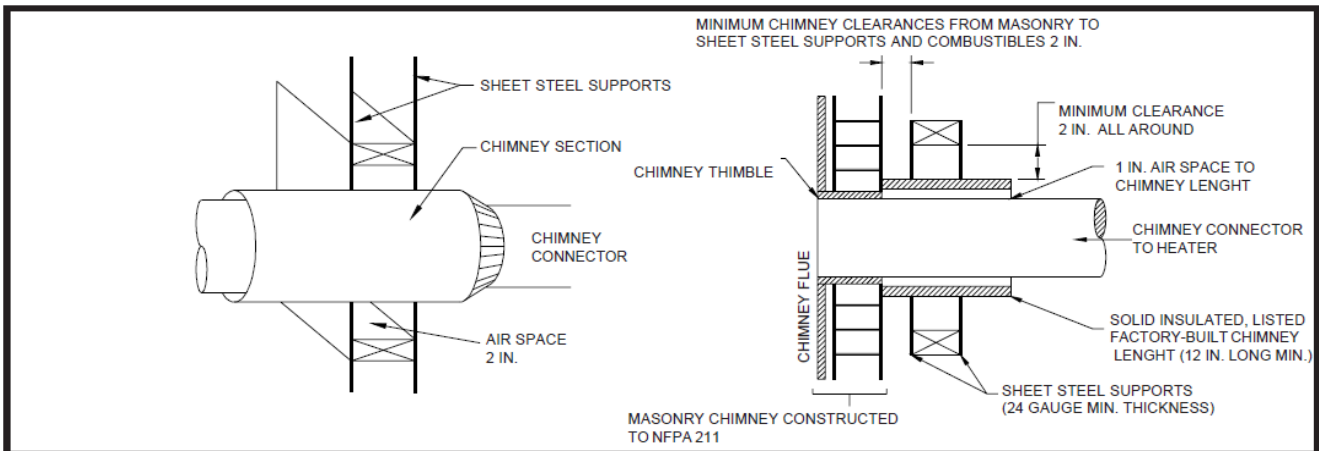
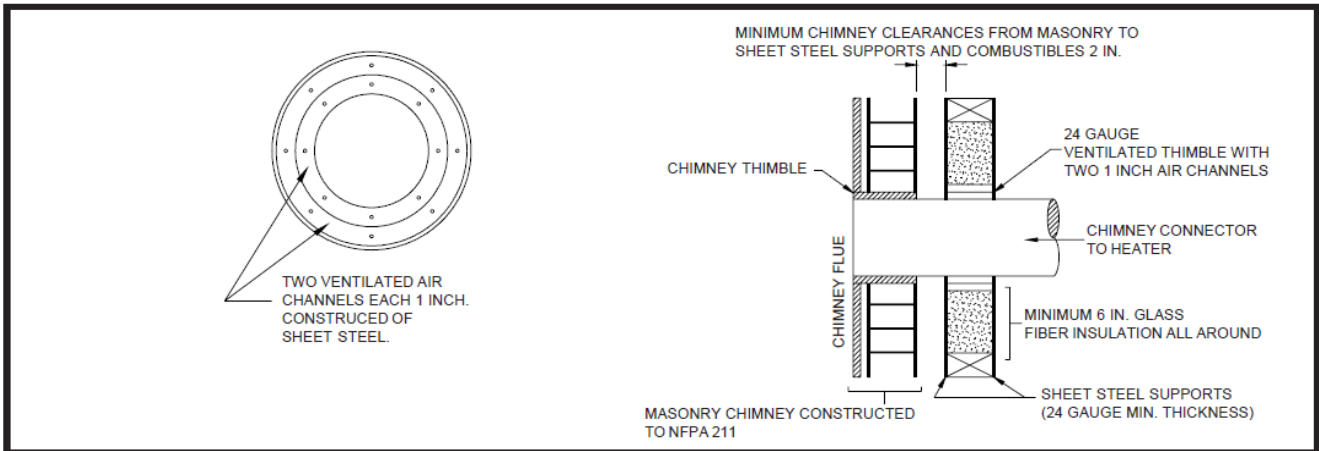
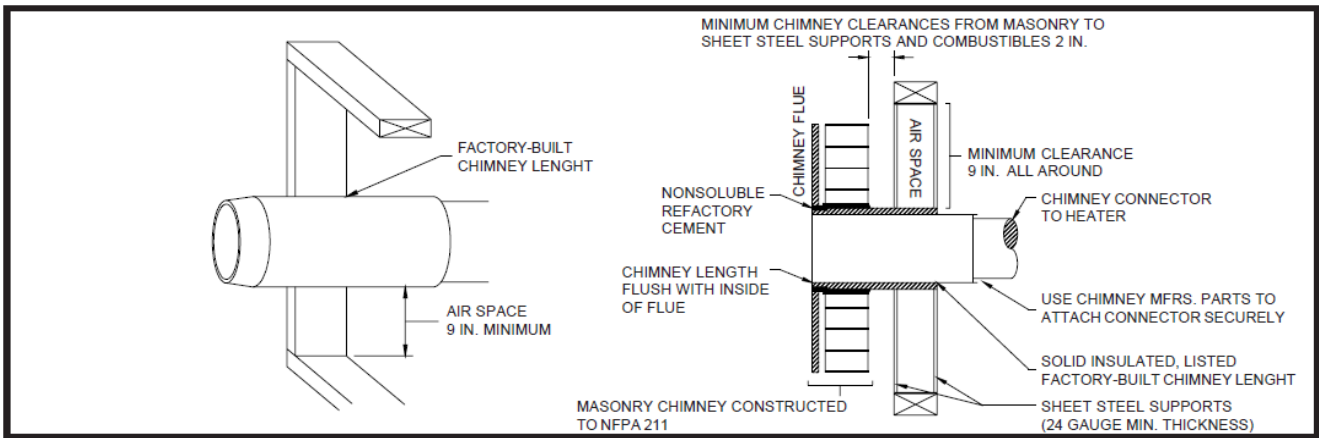

## **NRTL Listed (Class A) Chimney**

Carefully follow the chimney manufacturers instructions. Use only listed type HT per UL 103, 6" inch diameter black or blued chimney connector with a minimum thickness of no less than 24 gauge. If your chimney starts at the ceiling you will need enough 6" inch pipe to reach the ceiling. The top of the chimney must be at least 3' feet above the roof and be at least 2' feet higher than any point of the roof within 10' feet.

### **Rules For Connector Pipe Installation**

1. Crimped end of the pipe must always be installed towards the heater. The pipe should slide into the flue collar. The pipe should fit firmly inside and be mechanically attached to the flue collar, locked with at least three (3) screws and sealed with furnace cement
2. If you have a pipe running horizontally, the horizontal length can not exceed 12' feet regardless of the height of the chimney. If the chimney is 24' feet or less in height, the height of the chimney must be at least twice the length of the horizontal run.
3. You must have at least 18" inches of clearance between any horizontal piping and the ceiling.
4. Secure any connector pipe joint with at least three (3) sheet metal screws and seal with furnace cement, including the joint(s) at the chimney.
5. It is recommended that not more than four (4) bends of 90 degrees OR any amount of bends regardless of direction exceeding a total of 360 degrees be used in the pipe installation as more than that can cause a decrease in draw and may cause back draft or smoke spillage.
6. The chimney connector shall not pass through an attic, roof space, floor, wall ceiling, or any other similar concealed space. Where passage through a wall or partition of combustible is desired, the installation must conform with NFPA 211.

\*It is highly recommended that an insulated double wall pipe is used instead of a triple wall pipe. Though a triple wall pipe can and has been used successfully, in situations where the pipe is exposed outside the structure for long rises (such as a through wall installation) triple wall pipe does not have nearly as effective of a draft as insulated double wall pipe. Triple wall pipe does not insulate the chimney, instead it works via convection of cold air to cool the pipe. Due to the Rocket Heaters low exhaust gas temperatures the cooling effect of triple wall pipes design often prevents proper draft from being established in some installations.

Placement of the heater in a structure can also affect overall efficiency. For example, placing the heater in a main living area or towards the center of a home is typically more efficient than installing a heater in a basement, garage, or an outdoor area. This is because the outer rooms, such as bedrooms and attached garages, act as baffles to hold heated air inside the structure.

**Please Go to the Next Page for Diagrammatic Details  
and Clearances for NRTL Listed Class A Chimney Installation**

# Through Ceiling Installation

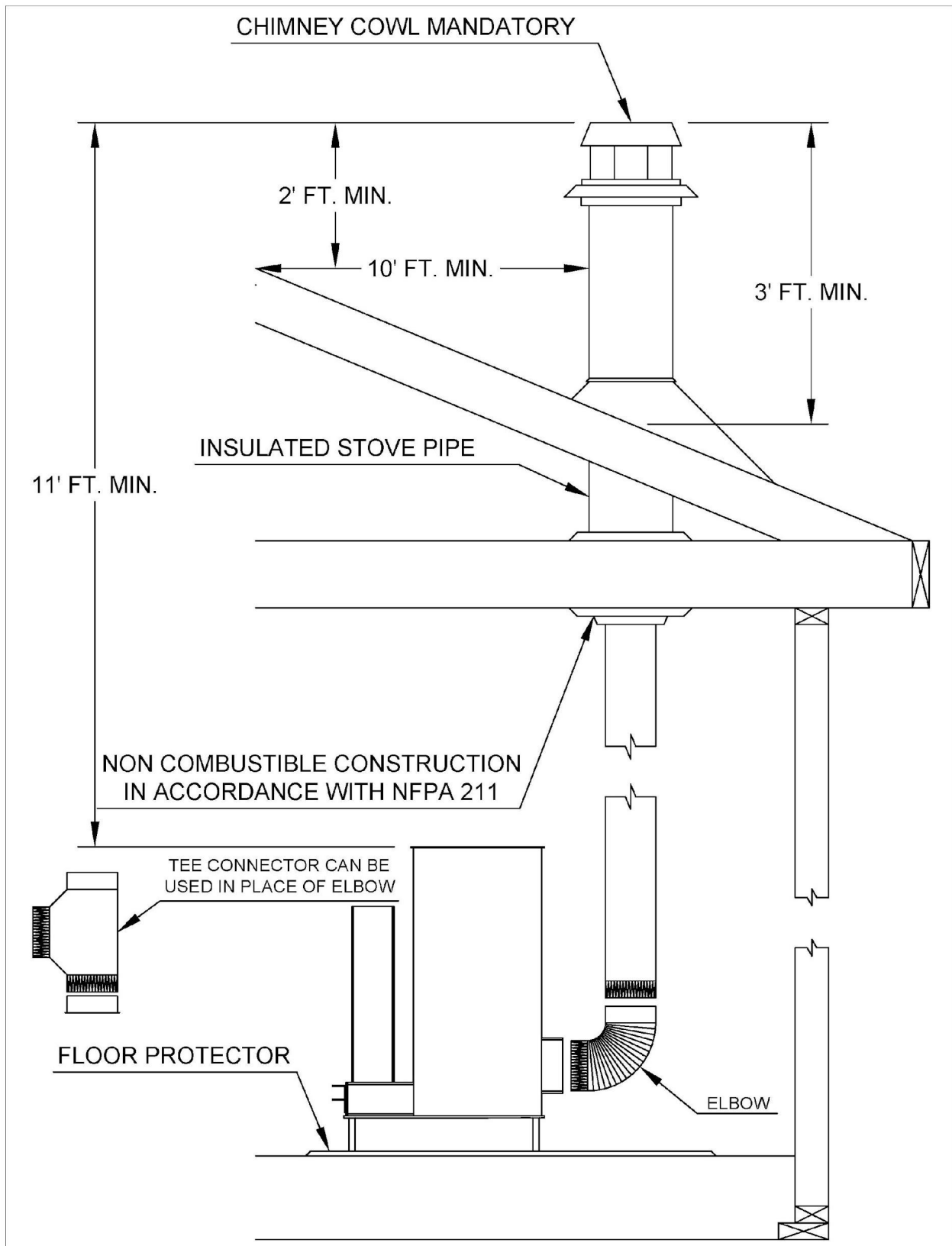

## Installation Of Combustion Air Inlet

The Rocket Heater has a 4" combustion air inlet on each side of the fuel feed tube. If the heater is to be installed in a mobile home a combustion air inlet (commonly/alternatively referred to as a "fresh air intake" or "outside air intake") the heater must draw its combustion air from outside the structure via the combustion air inlet. If the heater is being installed in a structure other than a mobile home you can but are not required to install a combustion air inlet. It is recommended that a combustion air inlet be installed as doing so increases the heater's efficiency.

### Rules For Installation of Combustion Air Inlet

1. Only one combustion air inlet is used at any given time. The other combustion air inlet must be capped off by inserting a crimped metal pipe cap and secured via sheet metal screws through the two screw holes.
2. When installing the combustion air inlet duct/pipework it is recommended to keep the pipe horizontal with as few bends as possible.
3. If you do use elbow(s), the sum of the angles of intake ductwork bends should not exceed 180 degrees. It is always recommended to keep the bends as gradual as practical. For example: two 45 degree angles are better than a 90 degree angle. No angles at all is almost always preferable.
4. All duct/pipe connections are to be secured with three sheet metal screws at the joints spaced approximately 120 degrees from each other. The only exception is where the intake pipe connects to the combustion air inlet collar. The collar has 2 holes spaced 180 degrees from each other. Secure the pipe to the collar using 2 sheet metal screws through those respective holes.
5. Never use flexible pipe such as dryer vent hose/pipe including (but not limited to) flexible pipes with a reflective/metallic appearance. Only rigid steel pipe is suitable for the air inlet.

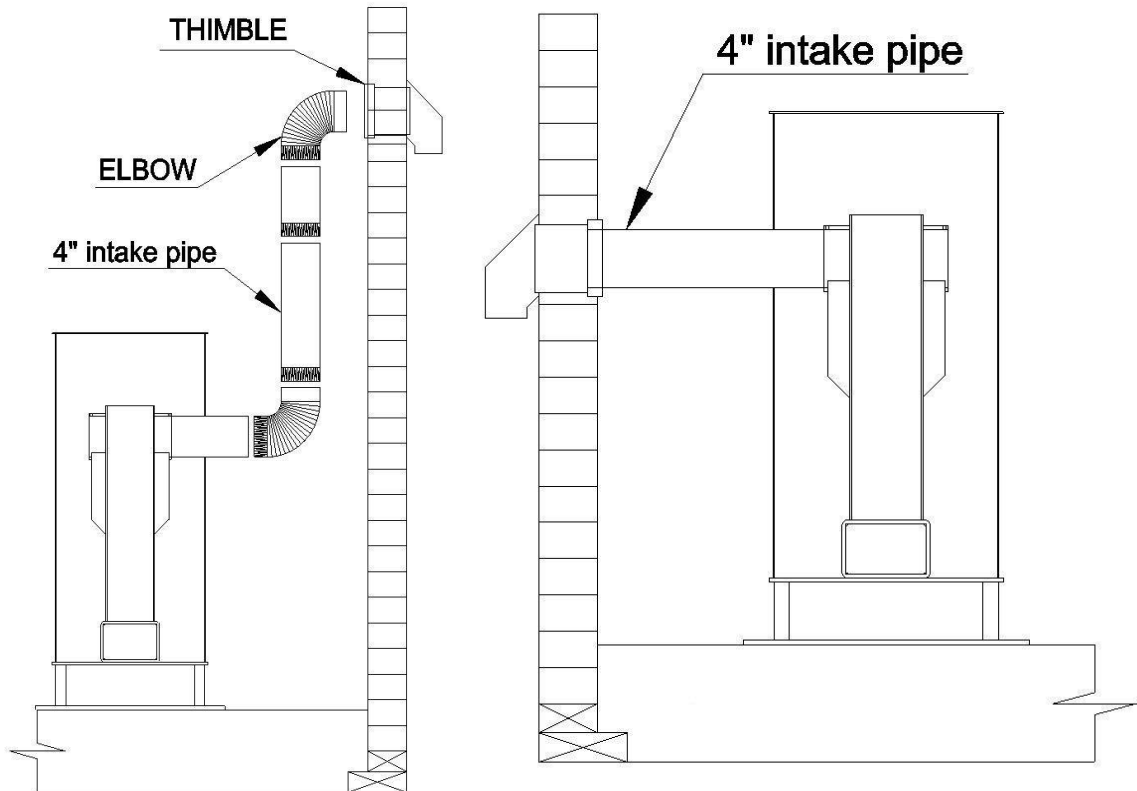

## **Integration of Rocket Heater to Thermal Mass**

The Liberator RMH-2.0 can be integrated to thermal mass, which converts it into a masonry heater. The benefits of using thermal mass is a thermal battery/flywheel effect which allows the stove to keep the structure warm without necessitating a continuous 24/7 firing. However, there are many variations of thermal mass integration and each installation is almost inherently a custom designed and built to the customers needs. It is highly recommended that an experienced mason, masonry heater, and rocket mass heater builder be contacted for individual assessment, assistance, and consultation.

### **Rules For Integration of Rocket Heater to Thermal Mass**

1. Do not encase the burn chamber of the RMH-2.0 with thermal mass.
2. When routing an exhaust pipe horizontally through thermal mass the horizontal section of pipe should have a rise going upwards towards the chimney of at least 3 degrees.
3. All clearances to combustibles guidelines must be adhered to. Thermal mass will not insulate, shield, or protect combustibles from the stove or exhaust pipe.
4. The floor must be capable of supporting the heavy thermal mass. A slab foundation is recommended. Contact a civil engineer if the thermal mass is NOT going to be installed on a slab and reinforce the floor as necessary.
5. The heat exchanging pipe should be at least 6” beneath any surface of the thermal mass.
6. The thermal mass must be made exclusively of non-combustible and non-flammable materials.
7. Do not use corrugated pipe. Keep bends to a minimum. You will still need to install the heater to a chimney as recommended in this manual. Use black stove pipe at least 24 gauge thick, secured by at least 3 screws at the joints. Do NOT route an exhaust vent directly out of the wall. You need a chimney for a proper draft! Use one of the chimney types described in pages 6-11 of this manual.
8. You can use a combustion air inlet when integrating the heater to thermal mass. In fact, we recommend it as it will increase the heater's efficiency.
9. The horizontal length running through the thermal mass can not exceed 12' feet regardless of the height of the chimney. If the chimney is 24' feet or less in height, the height of the chimney must be at least twice the length of the horizontal run.
10. Thermal mass can partially encase the RMH-2.0 directly in addition to encasing the horizontal run of the pipe. However, do NOT cover the cooktop, ash cleanout door, combustion chamber, or the top lid/fuel feed tube with thermal mass.
11. It is highly recommended that you be mindful of cleaning out the heat exchanging pipes and the chimney. Install T-connectors at convenient locations to give yourself access to the inside of the heat exchanging pipes of the thermal mass. Only use elbows in areas where a T-connector would not give you any added accessibility.

It is highly recommended that you consult experienced professionals in the construction of a true Rocket Mass Heater/Masonry Heater. Integrating a rocket heater to thermal mass is inherently a custom job that requires utmost care, consideration, knowledge, experience, and talent to design, construct, and operate. Though every installation and integration to thermal mass is by definition different and unique, on the next page are some example diagrams of some examples of basic installation layouts.

If you decide to integrate thermal mass to the Rocket Heater, RMH-2.0 we highly recommend reading “The Rocket Mass Heater Builder's Guide” by Ernie and Erica Wisner, ISBN: 0865718237 and contacting experienced masonry heater and rocket mass heater builders. The Masonry Heater Association of North America provides more information on masonry heaters and installers in your area.

# DIAGRAMMATIC DETAILS FOR THERMAL MASS

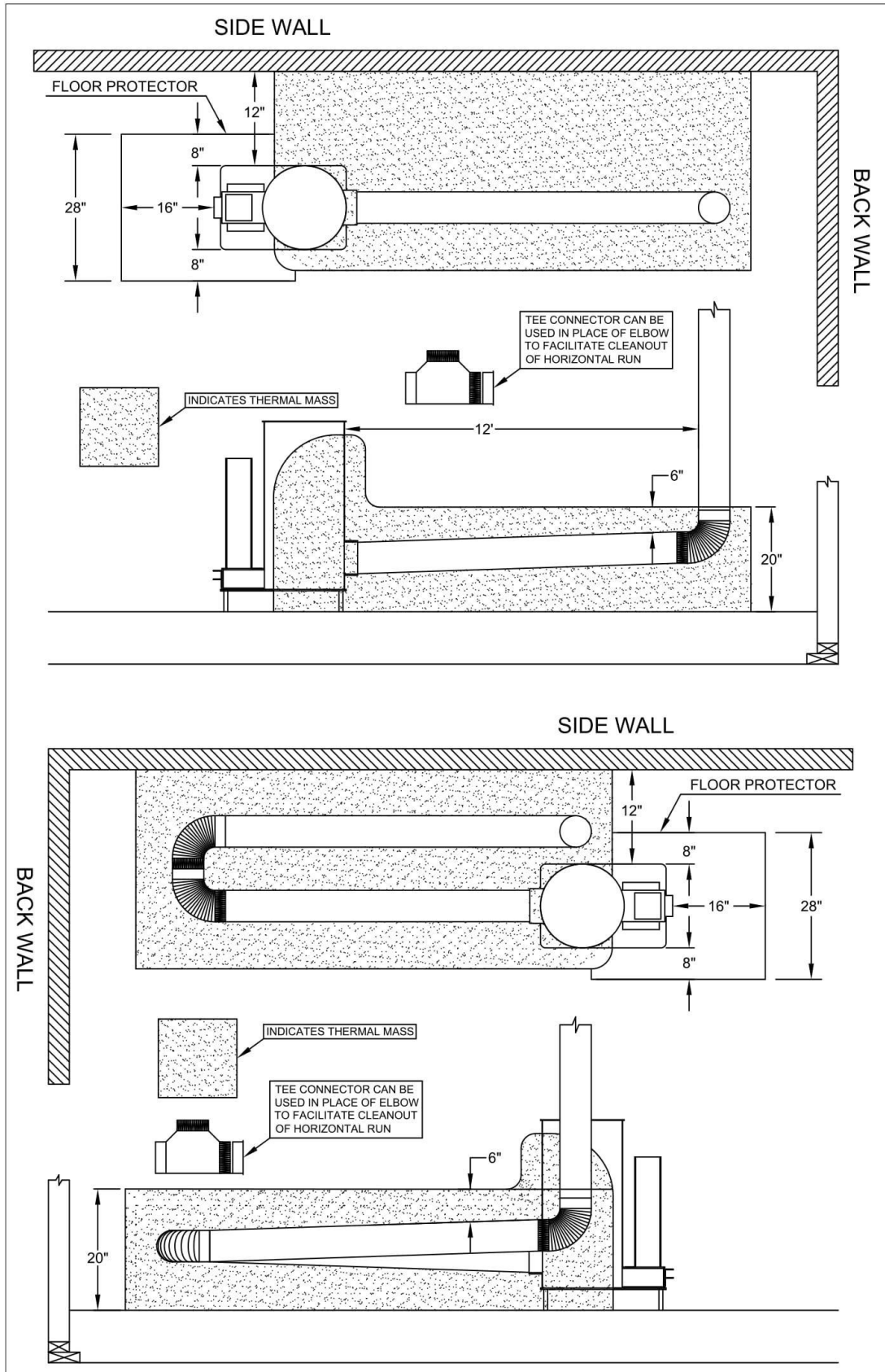

# Installation and Use of Flue/Chimney Damper

1. To install the flue damper, select one of the assembled sections of pipe (1) and measure its length. Make a mark (2) halfway down the length of the section at a point 90 degrees away from the section seam (3). Make a second mark (4) directly opposite the first mark (2) on the other side of the stack section (1). Drill (or punch) a ¼-inch hole at each mark. After drilling the two holes, insert the flue damper (5) inside the modified section (6) and align the holes passing through the flue damper with the holes drilled in the side of the stack section.
2. Thread the flue damper shaft (7) through the holes, locking the curved shank (8) of the flue damper shaft (7) into the center slot (9) of the flue damper. When properly locked together, the flue damper and operating handle (10) will be parallel.

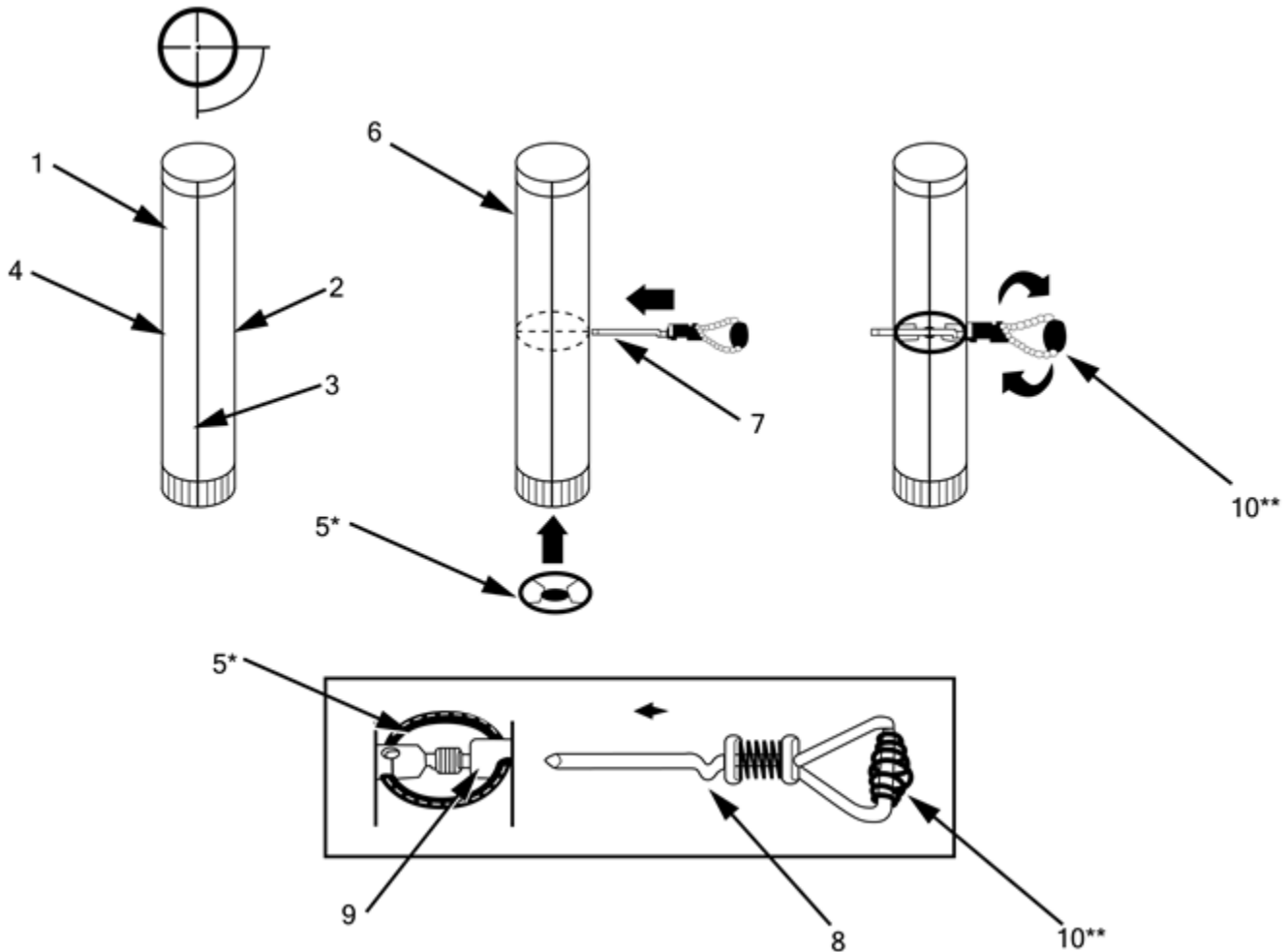

## How to Use Flue/Chimney Damper

A flue damper must be used responsibly and with caution. When lighting/starting the heater make sure to open the flue damper entirely for maximum draft. When the operating handle (10) is parallel with the vertical rise of the chimney, that is the open position. When it is perpendicular, it is closed. Be sure to first let the heater warm up to its maximum temperature and flow for at least 30 minutes. Then slowly and over a period of at least 10 minutes start to damper the stove. Dampening the stove slowly prevents backdrafting. Make sure the damper is open for the last 30 minutes of run time. Using a damper is especially beneficial in situations where there is too much draft.

# Installation Of The Pellet Hopper

The Pellet Hopper allows the Liberator RMH-2 to burn pellets without electricity, as it is a gravity fed single burn rate system.

## Steps to Attach the Pellet Hopper

1. Install the Pellet Feed Tube on to the Pellet Hopper by inserting the tube into the Coupler located on the bottom of the hopper.
2. Tighten the set screw (size 5/16" X 18 TPI) with the provided allen wrench.

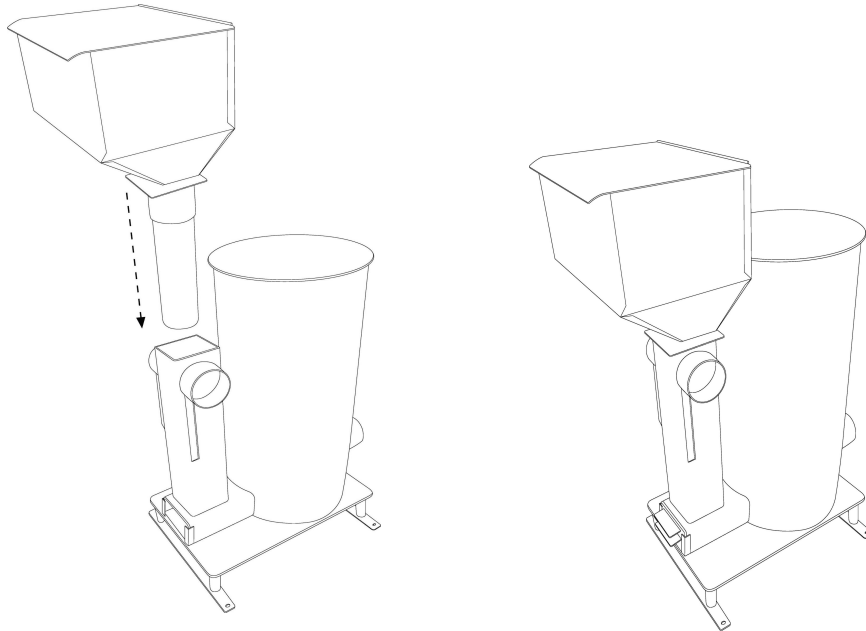

3. Place the Pellet Hopper on top of the fuel feed tube of the Rocket Heater. Make sure that the hopper is well seated and centered, and ensure that the pellet hoppers retainers (see next page) are properly set within the tube. Make sure that the hopper always has the lid flip up from the front with the hinge facing towards the back of the heater.

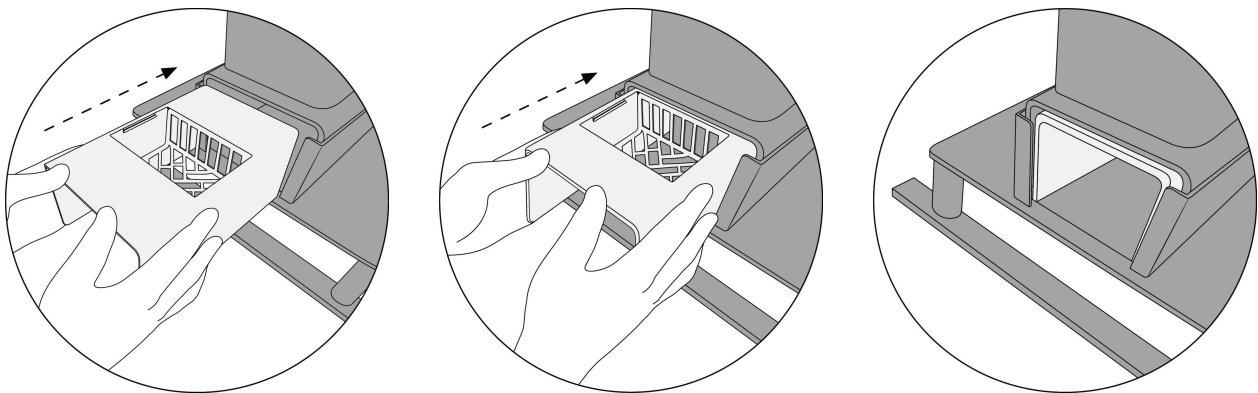

4. Open the ash cleanout door and insert the burn grate until the edge of the metal is within the tube just enough to allow the ash cleanout door to close again, ideally as close to making contact with the ash cleanout door as possible. Check and ensure that the Ash Cleanout Door can be fully closed. Close the door.



## Steps to Start the Heater on Pellets

1. Fill the hopper with pellets, then open the Ash Cleanout Door.
2. Use a propane torch to ignite the pellets. Make sure that the torch's flame is making contact with the fuel pellets and use a left to right sweeping motion across the bottom of the burn grate for approximately 25 to 30 seconds or until there is a steady draft.
3. Turn off the torch and place it well away from the heater. Leave the Ash Cleanout Door off for about 1 minute. Then close the ash cleanout door. The stove is now burning pellets.

**Shutoff Valve illustrated directly below**

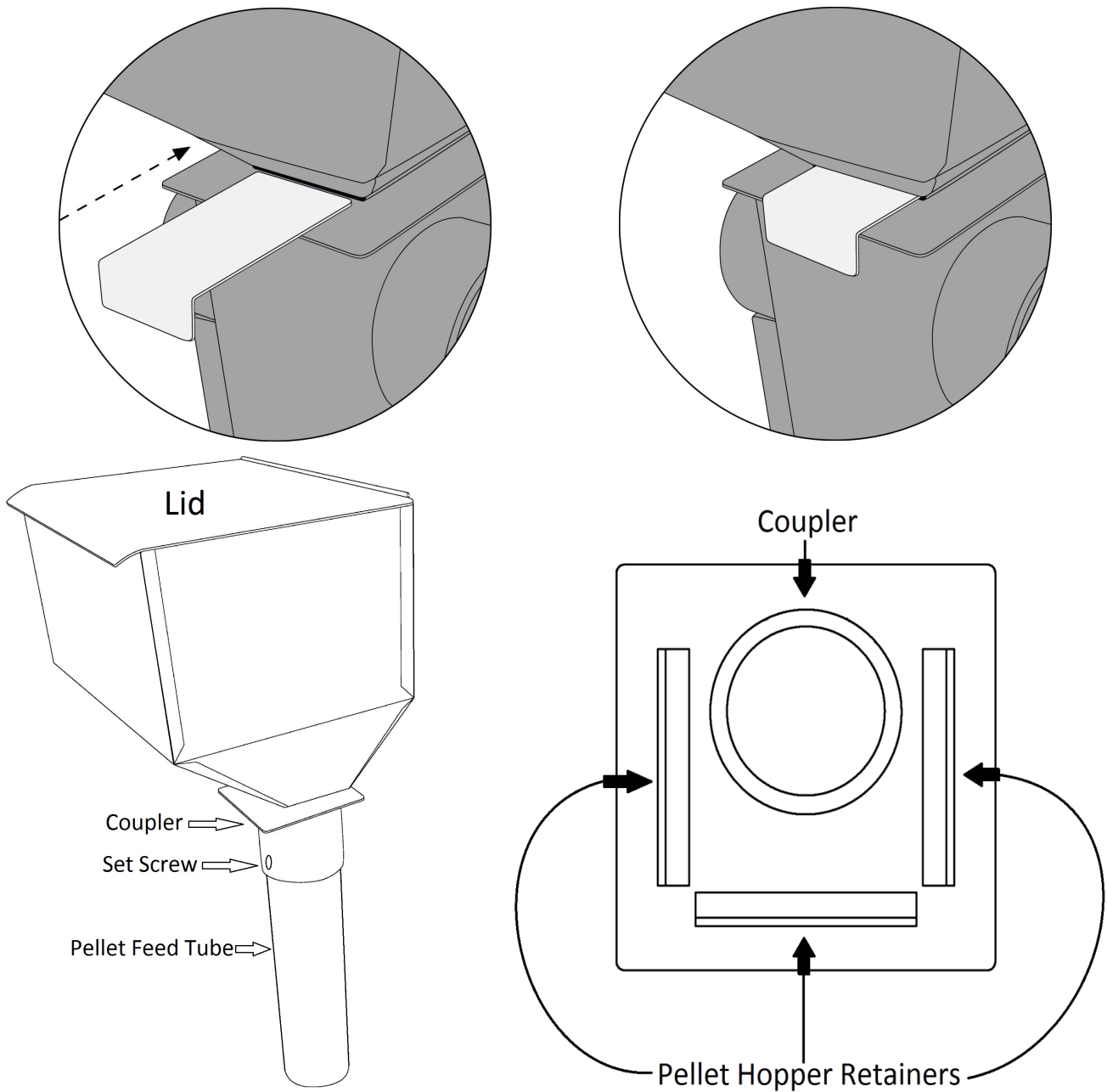

Note that there is a Shutoff Valve provided with the Pellet Hopper. This allows you to stop the flow of pellets down the pellet feed tube. The heater will run out of pellets in approximately 30 minutes to an hour from

the time you push in the Shutoff Valve. This is a Shutoff Valve, do not attempt to control the pellet flow or burn rate with the valve.

## **Final Draft Inspection**

Draft is the force which moves air from the appliance up through the chimney. The amount of draft in your chimney depends on the height of the chimney, local geography, nearby obstructions, and other factors. To check if your chimney is drafting correctly, open the lighting/cleanout door and put a lit match or cigarette lighter in front of the burn chamber. Then do the same (with the door closed) on top of the fuel feeding area. If the flame is being pulled into the stove it is regarded as safe. If there is no change in the flames direction, the draft is neutral. If the flame is being pushed away, the draft is negative. If the draft is neutral or negative, then you must reinstall the heater with less horizontal run. If you don't have a horizontal run, please call us (the manufacturer) or an expert for further advice. If the draft is too strong, the heater will either overfire and produce too much heat, which can damage the heater, or it can burn fuel seemingly fine but will not get up to the expected temperature/heat output as there is too much excess air that is inducing a cooling effect on the combustion process. In such an event, install a flue damper to reduce draft. Inadequate draft will cause the appliance to leak smoke into the room through appliance and chimney connector joints.

## **Gasket/Fiberboard Replacement & Maintenance**

This wood heater needs periodic inspection and repair for proper operation. It is against federal regulations to operate this wood heater in a manner inconsistent with operating instructions in this manual. The Liberator RMH-2 is lined with ceramic refractory fiberboard to protect the steel, increase efficiency, and increase the longevity of the heater. The refractory fiberboard is held in place by a combination of refractory cement, and mechanical stainless steel fasteners. There are a total of 9 refractory boards, 4 equally sized boards for the internal chimney, each being held in place by 2 stainless steel carriage bolts. The combustion chamber has 5 pieces of fiberboards, the top one being held in place by two stainless steel carriage bolts and the side pieces being held in place via mechanical fixation by two stainless steel elevator bolts. To access the internal chimney, you will need to remove the cooktop by loosening the three set screws that mechanically retain the cooktop on the heater, and then lift the cooktop off the heater. To replace the board, first remove all the old hardware and fiberboard, and thoroughly clean the surfaces of the steel combustion chamber. Apply lines of refractory cement to the new fiberboard, and press them on to the inside of the steel combustion chamber. Drill ¼” holes through the fiberboard, using the holes that are drilled into the steel as a guide. Place the washers on the carriage bolts, and press the bolts through the board and steel combustion chamber from the inside out, clean any debris from the threads of the bolt, lubricate the threads with oil, and tighten the nuts until the heads/washers of the bolts are flush with the refractory fiber board. The elevator bolts do not need washers. Do not overtighten, as that can weaken the mechanical strength of the board.

The cooktop gasket uses 5/8” diameter fiberglass rope seal. Alternatively, cryostile and/or asbestos may be used if The gasket will need to be replaced if damaged or if sealing ability is lost. Remove the cooktop by loosening the three set screws that mechanically retain the cooktop on the heater. Lift the cooktop off the heater, and remove the gasket using an appropriate tool, and be cautious of any sharp edges. Thoroughly clean the slot that gasket is seated into, and apply a thin bead of refractory cement at the bottom of the gasket slot. When placing the gasket into the slot, ensure to apply a light inward pushing pressure in line with the gasket, this will but the gasket under slight linear compression so as to puff out the gasket orthogonal to its direction as it is pressed into the slot. Do not pull or stretch the gasket as you insert it, as that can compromise the gasket's ability to form a proper seal.

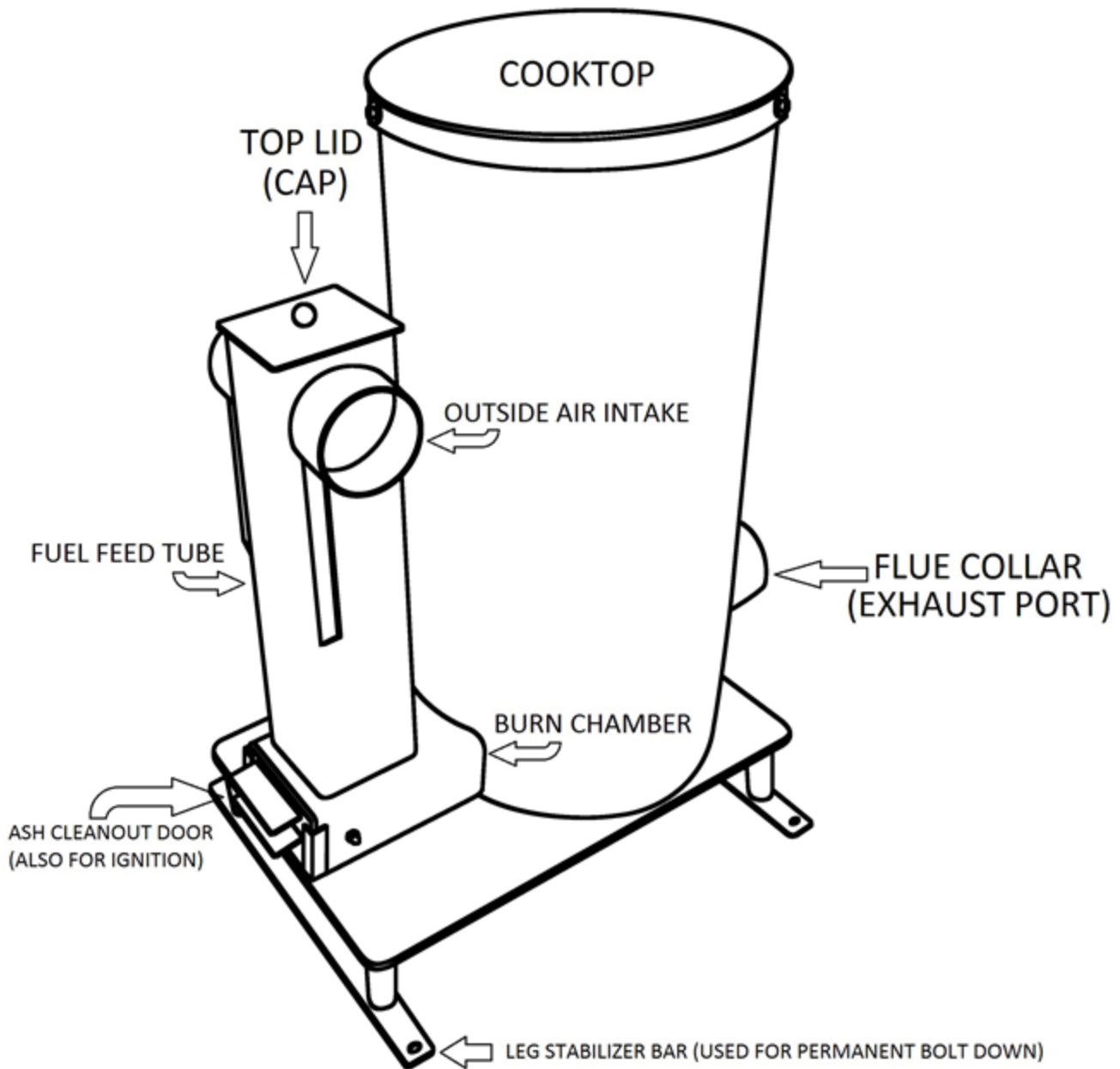

NEVER load fuel from the front door (the one that slides up and down). This door is only for lighting/startup and cleaning. Only load fuel from the top of the pellet hopper, or vertical tube if installed as a masonry heater. Specifically for the event of an emergency or chimney fire, keep a five gallon bucket of sand handy to pour into the fuel chamber. This will limit available oxygen to the chimney fire. Always have a fire extinguisher close by and at the ready. Remember, if the situation at hand could cause personal injury by attempting to close off the air supply, do not attempt to close the air supply, extinguish, or fight the fire. In such situations, evacuate the building, call 911, and let professional firefighters handle the situation. REMEMBER that your safety and the safety of others are of utmost concern and safety is the number one priority in any dangerous situation. Your well being and safety of others nearby in these circumstances should be the only determining factor for any actions to be taken. For more information and advice on fire safety, safety precautions, and what to do in an emergency contact your local fire department and/or the National Fire Protection Association.

# Operation as a Rocket Mass Heater

This Rocket Heater is EPA Certified for burning pellets. It was tested using pellet fuel to ASTM E2779 with Liberator RMH2 ATMS for single burn rate pellet heaters dated 9/9/2021 EPA OAQPS. It is not EPA certified to burn cordwood as a stand alone wood stove. However, this Rocket Heater can be integrated into thermal mass, which transforms it into a Rocket Mass Heater, which is a very specific type of Masonry Heater. Masonry Heaters are EPA exempt, partially owing to masonry heaters' historically exceptional performance and efficiency. When integrated into thermal mass, this Rocket Mass Heater becomes a multi fuel masonry heater capable of using both cordwood and wood fuel pellets (albeit not simultaneously). It must be emphasized that as a masonry heater it is not in any way similar to ordinary wood or pellet stoves and their operation. The engineering principles in this specific type of masonry heater are vastly different from almost every wood/pellet stove. Because of this, the operation is quite abnormal for most people and can take time to become accustomed to its use. Note that this heater has paint that is not cured upon arrival. When lighting for the first time, do it either outside or in a well ventilated area. Do not breathe the fumes given off.

It is recommended that you gather all the materials necessary to light the heater before you start it. The materials you will need to start this heater are as follows: a lighter or match, three oblong cigar shaped wads of paper, black and white newsprint, or equivalent whose width does not block air flow/passage, at least two handfuls of very small twigs not more than 1/8" inch in width, larger twigs about 1/4" to 1/2" inch wide, and running fuel not more than 1-1/2" inches in width. Be sure to use only dry, seasoned wood, as freshly cut, wet green wood increases pollution and reduces efficiency.

To light the rocket mass heater, first lift open and off the lighting and cleanout door. Inspect for any ashes from the last burn and clean out if ashes are present. Be sure that all paper wads are of an oblong cigar-like shape to prevent a blockage of airflow. Place the first wad of paper inside the burn chamber far enough from the front opening that it will not cause a fire but close enough that you can light it with your lighter or match. Once the paper is starting to catch fire, use the cleaning tool provided and push the wad all the way to the rear of the fire chamber. This will start a draft in the internal chimney. Immediately close the lighting door, making sure that no ashes or debris are preventing complete closure. Put a second wad of unlit (not on fire) paper down the vertical fuel tube. Immediately drop your handful(s) of small twigs on top of the unlit paper. Place a third wad on top and light it. The topmost wad of paper should be burning downward, which should catch the twigs and paper underneath. Once the twigs start to catch, place the medium fuel into the fuel tube. Once the medium fuel has lit, follow this up with your full size fuel that you will burn for general heating. When finished using, place the top lid on the top of the fuel feed tube. This will prevent cold air from coming in and/or hot air from leaving the house, which increases overall efficiency and reduces fuel consumption.