

# Installation and Maintenance Instructions For





# Product Information

## General Product Information

The quality and workmanship of **Forever Flex™** and **Armor Flex™** is reflected in the recognition Underwriters Laboratories has given these products. The rigorous UL testing and listing requirements, is your assurance of consistent quality in materials and manufacturing standards used for these lining systems. In addition, the industry leading Forever Warranty on **Forever Flex™** and **Armor Flex™** is a further indication of our confidence in the quality of these products. Thank you for choosing **Forever Flex™** and **Armor Flex™**!

The **Forever Flex™** and **Armor Flex™** stainless steel lining systems are UL and ULC listed in 3”(7.6cm) to 12”(30.5cm) diameters.

**The lining system must be installed by a qualified chimney or venting professional.**

The criteria for installation must be in conformance with the specifications in the NFPA 211 (Standards for Chimneys, Fireplaces, Vents and Solid Fuel Burning Appliances), National Building Code of Canada and local or state building codes, whichever has jurisdiction. **Contact local building or fire officials about restrictions and installation inspection in your area.** It may be necessary to obtain permits before installing the chimney liner. Contact the local building authority for permit information.

## Product Applications

The **Forever Flex™** and **Armor Flex™** lining system is intended for use with heating appliances burning home heating oil, natural or LP gas and solid fuels (pellet, wood and coal) vented through a masonry chimney. Use 304 type stainless steel **Armor Flex™** and 304L type stainless steel **Forever Flex™** for wood pellet stoves, wood burning stoves and fireplaces. Use 316 type stainless steel **Forever Flex™** and **Armor Flex™** for wood burning appliances, coal burning appliances, oil burning appliances, gas burning appliances, and solid fuel burning appliances. Use AL 29-4C type stainless steel **Forever Flex™** for high efficiency appliances. (**Forever Flex™** in AL 29-4C should **not** be used with wood burning appliances). Use of experimental fuels is not permitted and voids the warranty. This lining system is not intended for use with high efficiency appliances that require type BH gas venting systems, or that create positive pressures in the chimney.

The **Forever Flex™** and **Armor Flex™** system is intended for use in (1) new masonry chimneys, lined or unlined, with at least (a nominal) 4”(10cm) of masonry all around, (2) an existing, properly built masonry chimney with cracked clay tile liner. The lining system is intended to provide a properly-sized flue for a heating appliance installed in a masonry chimney that otherwise meets existing codes.

The **Forever Flex™** and **Armor Flex™** liner may also be used as a flue for a fireplace. The liner must be connected to the top of the smoke chamber by means of a bottom plate or other means, which provides an air-tight and drip-free termination.

## Chimney Inspection and Cleaning

Prior to installation of the lining system thoroughly inspect and clean the chimney. All creosote (including tar glaze creosote), soot, dirt and debris must be removed before the installation of the liner. Thorough cleaning of the chimney is a warranty prerequisite. The chimney must be inspected for cracked, loose or missing- stones, bricks or mortar joints. A chimney that is not structurally sound should not be relined. Make any repairs necessary before proceeding with the installation of the liner.

As a precaution it is recommended that a short piece of lining material of the diameter to be installed is connected to a pulling cone and is drawn through the masonry chimney. This will ensure that no obstructions exist that should be removed and will result in a smoother installation of the system.

## Clearances

### Inside the masonry chimney:

Minimum air space clearance of the liner to the interior surfaces of the masonry chimney to be maintained is zero millimeters (inches). The flue passageway must be checked for the smooth installation of the proper diameter liner. The chimney must be built of solid masonry brick, block or concrete blocks at least (a nominal) 4 inches (10cm) in thickness.

### Exterior of Masonry Chimney:

The surrounding chimney construction shall comply with the NFPA 211 code, CAN/CSA-A405, Design and Construction of Masonry Chimneys and Fireplaces and/or the National Building Code of Canada. Clearance to combustibles must meet or exceed the requirements contained in the above mentioned codes, all applicable local building codes, and the manufacturer's installation requirements. Note insulation requirement section, which can permit zero clearance from exterior of masonry to combustibles in some cases.

### Termination Above Roof:

The termination of chimney above a roof must be in accord with the requirements contained in the NFPA 211 code and/or CAN/CSA-A405. This code requires that a chimney terminate at least 3feet (0.9m) above the point where it penetrates the roof and 2 feet (0.6m) higher than any structure within a 10 foot (3m) radius. All Forever Flex installations must utilize a U.L or U.L.C. approved chimney cap.

### Wall Penetration:

For wall or chimney penetrations other than listed in our installation instructions consult the NFPA 211 code and/or CAN/CSA-A405 code and any other local codes. Wall penetration assemblies cannot be located directly behind a heating appliance.

## Sizing the Liner

For Solid Fuels, the liner is to be sized in accordance with the actual size (square inches or centimeters of the cross-sectional area) of the exhaust opening of the appliance, unless otherwise specified in the manufacturer's instructions. To determine the proper diameter of liner for Oil Burning Appliances refer to the NFPA 31 Oil Standard, the National Building Code of Canada, the Installation Code for Oil Burning Equipment, CAN/CSA-B139, or the appliance manufacturer's instructions; for LP or Natural Gas Burning Appliances refer to the NFPA 54 Fuel Gas Code Book, CAN/CGA-B149.1 and CAN/CGA-B149.2 or the appliance manufacturer's instructions. Local and/or state building codes, whichever is the authority having jurisdiction, may specify other sizing requirements.

If the liner is for a fireplace chimney, the cross sectional area of a round liner is to be a minimum of 1/12<sup>th</sup> of the area of the face opening of the fireplace. Oval, square or rectangle shaped liners shall be a minimum of 1/10<sup>th</sup> of the area of the face opening of the fireplace.

The overall length of the liner system will be determined by the components required, the height of the masonry chimney and the top termination. The system should be a minimum of 8 feet (2.5m) in height but not greater than 75 feet (22m). If using two or more liner sections joined together by means of a connector, any connector should support no more than 50 feet (15m) of liner. When connectors are used to join two or more Armor Flex liner sections use four #8 X 3/4" (M4 X 20) self-tapping stainless steel screws 90 degrees apart on the male and female ends of the connector is required, whether the hose clamp bands are used or not.

### Ovalized, Rectangularized or Squarized Liner:

If a round liner will not fit the inside dimensions of a chimney, **Forever Flex™** and **Armor Flex™** liners may be ovalized, rectangularized or squarized at our factory to allow for proper fit. Keep in mind any change in the original round shape of the liner will alter its cross-sectional area. Refer to Olympia Chimney Supply's shaped liner charts found in every catalog or call for calculation assistance when ordering factory approved, shaped liner. In fitting any factory-fabricated (ovalized, rectangularized or squarized) liner, you must ensure that you still maintain the required cross-sectional area of the liner required for the appliance to be connected. In addition, when installing a factory-fabricated shaped liner, a 1 inch (25.4mm) clearance from the outside of the masonry chimney to the surrounding combustibles must be maintained.

## Insulation Requirements

### For Solid Fuel Applications-

Insulation provided for the **Forever Flex™** and **Armor Flex™** system will be a single ½” (13mm) thick or two ¼” (6.5mm) layers of insulating blanket. This insulating system is listed to allow zero clearance from the chimney masonry exterior to combustibles. The 8 lb. density insulating blanket must be wrapped around the entire length of the liner in an unlined, partially lined, or cracked clay tile liner application.

**Alternative EverGuard™ Insulation Mix or TherMix® Insulating method:** The **Forever Flex™** and **Armor Flex™** lining system can be insulated using EverGuard™ Insulation Mix or TherMix® brand insulating material. A 1 inch (25mm) layer of **EverGuard™ Insulation Mix** or **TherMix®** between the liner and 4 inch (10cm) nominal masonry provides a zero clearance listing from the chimney masonry exterior to combustibles. If the clay tile liners are in good condition and the chimney meets existing codes, no insulation is necessary.

### For Oil or Gas Applications-

**Forever Flex™** and **Armor Flex™** are listed to be installed without insulation for oil and gas appliances in an unlined, damaged clay tile lined, or good condition clay tile lined chimney. Oil and gas appliances do not require a minimum clearance between the outside of the liner and the inside of the masonry chimney. Olympia Chimney Supply has listed **Forever Flex™** in this manner recognizing that insulation can cause clearance issues in certain masonry chimneys. However, it is good practice to insulate even with gas or oil appliances to stabilize draft and minimize condensation. One layer of ¼” (6.5mm) insulation is an excellent way to meet this need. See insulation installation instructions for further information.

## Forever Flex and Armor Flex System Materials

Use of any parts or materials not specified in this installation manual may not provide a listed system.

### Approved Connections:

Approved connections of **Forever Flex™** and **Armor Flex™** system are, (1) a tee section, (2) a U.L. listed direct connect system, (3) a connector directly attached to the heating appliance, (4) a masonry fireplace flue.

### Approved Components:

Olympia Chimney Supply products have been U.L.C. tested with the **Forever Flex™** system. These approved components include, (1) Liner, (2) Top Plates, (3) Support Top Clamp, (4) Storm Collars, (5) Round Chimney Caps, (6) Screw Supports, (7) Tee connections, (8) Universal connectors, (9) Insulating wrap, (10) Retractable wire mesh, (11) Clamps to secure insulation, (12) Aluminum Foil Tape, (13) **TherMix®**, (14) **EverGuard™** Insulation Mix, (15) Stainless steel self-tapping screws.

# Installation Instructions

## 1-Preparing the Liner for Installation

(CAUTION- ENDS OF LINER AND EDGES OF CAP, TOP PLATE, TEE AND CONNECTORS CAN BE VERY SHARP! OLYMPIA CHIMNEY SUPPLY RECOMMENDS THE USE OF GLOVES DURING INSTALLATION.) (WARNING- WATCH OUT FOR OVERHEAD POWER LINES DURING INSTALLATION)

- a) Remove the liner and components from the packaging. On a flat level surface roll out and straighten the lining material.
- b) Attach the necessary bottom termination connector, which may be a tee or a universal connector to the liner by inserting the liner into the connector as far as possible. Then, using a 5/16" (8mm) nut driver tighten the hose clamp band firmly around the liner. **Caution- do not over tighten the clamp!**
- c) To find the length of the liner needed, measure from the point at which the bottom connector will stop in the chimney to the top of the chimney crown and add 12" (30cm). This will be the total length of liner needed. Cut the liner to size as needed. When cutting Armor Flex the use of a grinder, circular saw, or reciprocating saw with a metal cutting blade is recommended. File or grind any rough or sharp edges for your safety.

## 2-Insulating the Liner (if required)

### **Method #1 Using Insulating Blanket Wrap**

(CAUTION- FOIL EDGES OF INSULATION ARE VERY SHARP!)

- a) Always ensure that the bottom connector has been installed (tee or universal connector).
- b) The liner must be insulated from the bottom of the connector (in the case of a tee from where the tee cap is installed up and in the case of a universal connector from where the connector would stop on insertion into the heating appliance) to the crown. In the case of Armor Flex, the insulating wrap must be 6" (15cm) below the crown to allow for vertical thermal expansion. After determining this length, roll out the insulating wrap and cut to this length.
- c) The insulating wrap must overlap along its length by a minimum of 1" (2.5cm). To ensure you have the proper width of insulating wrap multiply the liner diameter by 3.14 plus 1" (2.5cm) for overlap. You may trim the width of the insulation to this amount but is not necessary. A wider overlap is allowed but may cause installation difficulties in tight clearance situations.
- d) With the insulating wrap rolled out (foil face on the ground) on a level surface, lay the liner and its bottom termination connector (which was previously attached) in the center of the insulation. At the bottom end of the insulation line up the bottom connector as outlined in step b) above. Remember that at the top the insulation will be even with the chimney crown.
- e) Begin wrapping the insulation around the liner. After overlapping the wrap by at least 1" (2.5cm) hold the wrap in place at approximately 1 foot (30cm) intervals with foil tape. You may also use spray adhesive to assist you in holding the insulation against the liner.
- f) Once insulation is in place apply a continuous vertical length of foil tape from the top to the bottom of the overlapped insulation seam.
- g) Now encapsulate the insulated liner using retractable wire mesh. Unroll the correct size mesh and pull it over the entire length of insulated liner. At the bottom of the insulation secure the mesh and insulation in place with a stainless steel hose clamp. Now at the top of the liner, stretch the wire mesh tight and while holding mesh tight, clamp the insulation and wire mesh in place using a stainless steel hose clamp. Trim away excess mesh. With long liner lengths or tight clearances you may also wrap the entire length of insulated liner with stainless steel wire, spirally wrapped and then twisted on itself at each end to hold it in place. You are now ready to install the liner.

## Method #2 Using EverGuard™ Insulation Mix or TherMix® Insulation

- a) **EverGuard™** Insulation Mix or TherMix® is poured into the chimney after the liner is installed. **EverGuard™** Insulation Mix or TherMix® is a pre-mixed insulation material that only requires the addition of water at the installation site.
- b) To prepare **EverGuard™** Insulation Mix or TherMix®, empty bag(s) into a mortar mixing box or wheelbarrow. Add 4 to 7 gallons (15 to 26.5 liters) of water per bag of **EverGuard™** Insulation Mix or 7 to 9 gallons (26.5 to 34 liters) of water per bag of TherMix® and mix with a hoe or other mixing tool. You have achieved the proper consistency and water content when the material is damp, but still granular. Squeeze a handful of your mixed material - little or no water should appear. Properly prepared **EverGuard™** Insulation Mix or TherMix® is able to be poured into the void between the liner and the chimney like “loose fill”.
- c) When pouring **EverGuard™** Insulation Mix or TherMix® between the liner and the chimney, distribute the material evenly around the liner. Spacers may be used to center the liner in the chimney cavity.
- d) Vibrate the liner by firmly tapping it and continue to pour in insulating material until the chimney is filled to the top. In the case of **Armor Flex™**, the insulating material must be 6” (15cm) below the crown to allow for vertical thermal expansion. Be sure no **EverGuard™** Insulation Mix or TherMix® has fallen into the liner.
- e) All heating appliances or fireplaces can be fired right after installation. Keep flue gas temperatures below 700 degrees F (371 degrees C) for a period of three weeks. This allows for a gradual drying process of the insulating material.
- f) Remember a 1” (2.5cm) layer of **EverGuard™** Insulation Mix or TherMix® between the liner and 4” (10cm) nominal masonry provides a zero clearance listing from the chimney masonry exterior to combustibles.

### 3- Installing the Liner

**Be sure to check above and around the chimney for antennas, power lines, or any other obstacles before beginning the installation. Be sure that the liner does not come in contact with electrical or any other wires.**

- a) In some installations the use of a high quality pulling cone may be necessary.
- b) The height of the structure, roof pitch and other factors will influence how you determine to lower the liner into the chimney. Do not install a longer length of liner than the available manpower can handle.
- c) Lower the liner from the top of the chimney, keeping it centered in the flue opening and away from the edges. This will protect the liner and the insulating wrap. You may need to have someone at the bottom of the chimney with a rope (caution: do not use a metal conductive chain) attached to the pulling cone to assist in guiding the liner into the chimney. **DO NOT FORCE THE LINER INTO A CHIMNEY.**
- d) Once the bottom of the liner or bottom connector is at its desired position, trim the top of the liner to 4” (102mm) above the crown. (For **Armor Flex™** installations, it is recommended that the tee be secured and supported within the chimney. For **Forever Flex™**, this is especially necessary in the case of long lengths of liner exceeding 35 feet (10.6m). This can be accomplished using angle iron.)

## 4- Completing the Top Termination

### *For Forever Flex*

- a) With the tee or universal connector held in place at the bottom, place a heavy bead of silicone caulk around the chimney crown or top of clay flue tile, if it extends above the crown. Place top plate over the liner and press firmly into silicone caulk. (Top plate may be trimmed as needed).
- b) Using a 5/16" (8mm) nut driver, tighten the hose clamp band around the liner. **Caution- do not over tighten the hose clamp band!** This secures the liner to the top plate. Optional: Top plate flashing has four predrilled holes, which can be used to Tapcon the top plate to the crown.
- c) Install the cap by fitting it over the collar of the top plate. Tighten the hose clamp band of the cap onto the top plate collar. Your top termination is now complete.

### *For Armor Flex*

- a) With the tee or other bottom termination held in place at the bottom- place a heavy bead of silicone caulk around the chimney crown or top of clay flue tile, if it extends above the crown. Place top plate over the liner and press firmly into silicone caulk. (Top plate may be trimmed as needed and may be attached with Tapcons to the crown if desired).
- b) Install top support clamp by preassembling the two (or three) sides of the clamp, but only thread the nuts onto the bolts partially. Slide the support clamp over liner and push down until the clamp contacts the top plate. Tighten the support clamp bolts to secure the clamp to the liner. Note: Do not fasten or mortar the liner directly to the chimney or crown. The support clamp method allows for the vertical expansion of rigid liner that occurs during the heating process. (An alternate clamping method will be the use of support "L" brackets bolted to the liner, which are necessary for oval, square and rectangle shaped liners).
- c) Slide the storm collar over the liner and tighten clamp screw. A bead of silicone caulk between the liner and the storm collar will seal this joint from water leakage.
- d) Install the cap by fitting it inside the liner. Secure the cap to the liner with 4 rivets or stainless steel screws. Your top termination is now complete.

*With Forever Flex and Armor Flex you have options ...*

### **Hose clamp causing problems in tight clearance situations?**

In some tight clearance installations, we realize the worm screw on the fastening hose clamp can cause problems. In these situations, remove the hose clamps and cut off the straps that secure the hose clamps to the tee or the universal connector. Then using four #8 X 3/4" (M4 X 20) self-tapping stainless steel screws (90 degrees apart) secure the liner to the connector or tee. It is necessary to use the "liner screw support" fitting, which slides inside the liner, at the female end of the connector or tee, for the strongest connection possible when using self-tapping screws. **This method of fastening still provides you with a UL listed system!**



## Alternate Chimney Top Terminations for Forever Flex

The standard chimney top termination for a Forever Flex lining system is the use of a Forever Flex top plate and cap. However, some installations may require or you may desire an alternative top termination. Other chimney top terminations are approved as follows.

- 1- **Liner, mortar secured, to crown with any listed rain cap:** Insulate liner to within 4" (10cm) of chimney top. Fill the remaining 4" (10cm) with mortar or crown mix and form a slope from the liner to the outside edge of the chimney. Attach listed cap to the liner.
- 2- **Liner, mortar secured, to clay flue tile with any listed rain cap:** Insulate liner to within 4" (10cm) of chimney top. If not already existing, slip a full or partial length clay flue tile over the liner. Fill the gap between the clay flue tile and the chimney with mortar or crown mix and form a slope from the flue tile to the outside edge of the chimney. Fill the gap between the liner and the flue tile with mortar or crown mix. Attach listed cap to the liner.
- 3- **Slate Flue Covers:** In many residential communities slate flue coverings may be desirable. However, sufficient protection from precipitation and debris must be ensured. To make certain of this protection do the following: (1) Determine the distance between the top of the liner and the bottom of the slate covering, (2) Divide this measurement by 2.5, (3) This number gives you the minimum overhang of the covering past the edge of the liner. [Example: the covering is 12" (30cm) above the top edge of the liner. Divide 12" (30cm) by 2.5, which equals 4.8" (12cm). The covering must extend at least 4 3/4" (12cm) in all directions past the liner opening.] This provides a minimum 22.5 degree angle from liner edge to covering edge.

## Alternate Chimney Top Terminations for Armor Flex

The standard chimney top termination for a Armor Flex lining system is the use of a top plate, clamp, storm collar and cap. However, some installations may require or you may desire an alternative top termination. Two other chimney top terminations are approved as follows.

- 1- **Use of any listed rain cap:** If existing flue tile will protrude a minimum of 1" (2.5cm) above crown, trim top plate to outside dimensions of flue tile. Silicone top plate to flue tile and secure support clamp to the liner. Now install a square or rectangle listed cap bolted to the flue tile (Ensure the liner does not protrude excessively into the cap so as to restrict flow.). If no flue tile is protruding above the crown, use of a flue tile extension may be needed to secure the cap to the chimney. If installing a round listed cap, use of a storm collar may be necessary to keep precipitation from going between the liner and top plate.
- 2- **Slate Flue Covers:** In many residential communities slate flue coverings may be desirable. However, sufficient protection from precipitation and debris must be ensured. To make certain of this protection do the following: (1) Determine the distance between the top of the liner and the bottom of the slate covering, (2) Divide this measurement by 2.5, (3) This number gives you the minimum overhang of the covering past the edge of the liner. [Example: the covering is 12" (30cm) above the top edge of the liner. Divide 12" (30cm) by 2.5, which equals 4.8" (12cm). The covering must extend at least 4 3/4" (12cm) in all directions past the liner opening.] This provides a minimum 22.5 degree angle from liner edge to covering edge.

## **5- Completing the bottom termination**

### **Bottom Tee Terminations-**

- a) Locate the point where the connector pipe will pass through the chimney to the tee body. There must be an opening large enough for the diameter of the connector pipe plus 2" (5cm).
- b) If insulated- cut away the wire mesh and insulating wrap where the removable snout will attach to the body of the tee. Only remove enough insulation to connect the snout.
- c) Secure the snout to the body of the tee using the attached metal band, which wraps around the backside of the tee body. Ensure that the snout is fitting properly to the tee body while securing the metal strap.  
Note: certain size tees have fixed snouts.
- d) If insulated- wrap the snout (and any extension pipe used to extend beyond the exterior of the chimney face) with ½" (13mm) insulating wrap. Wrap the insulation a minimum of 1" (25mm) beyond the exterior of the chimney face. Remember the insulating wrap seam and where it meets the tee body insulation must overlap a minimum of 1" (25mm). The seam of the wrap and where it meets the tee body must be covered with foil tape. This snout insulation may be held in place with wire but is not necessary.
- e) Fill in the hole around the snout with brick and mortar.
- f) Complete your connection to the heating appliance following all applicable codes. Please see page 11 for reference diagrams of chimney connector systems and clearances from combustible walls for residential heating appliances.

## Universal Connectors or other terminations-

- a) The universal connector may be connected to the exhaust collar of an appliance following the manufacturer's fastening specifications.

### Universal Take-Off (UTO) Installation

The universal take-off (UTO) may be used when additional gas or oil appliances need to be vented into a Forever Flex liner or when a UTO is used in place of a standard round tee section on an ovalized, rectangularized or squarized liner. When using a UTO the liner must be at least 1" (25mm) larger in diameter than the diameter of the UTO. To install a UTO:

- 1- If it does not exist cut a hole in the masonry chimney at the point where the UTO will be installed into the liner.
- 2- Cut a hole in the liner using the appropriate diameter hole saw (with a pilot drill bit). Make the pilot hole through the liner, then when cutting the main hole switch the drill to reverse. Press the hole saw into the liner firmly until the hole is cut completely through. Remove the cutout from the liner.
- 3- Feed the UTO draw band around the liner and into the turnbuckle. Tighten the draw band firmly around the liner.
- 4- Apply a bead of high-temp RTV silicone between the UTO and the liner.

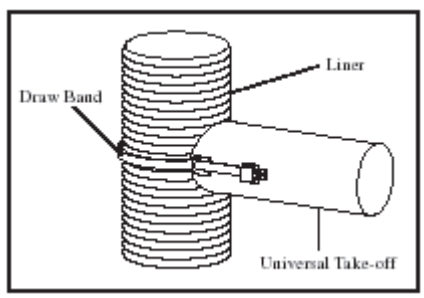

## 6- Congratulations!

You've successfully completed your installation. Please review the maintenance and warranty information with the end-user. Your compliance with these installation instructions and applicable codes will ensure your customer long-lasting satisfaction.

**Note:** As with any venting system, the performance & safety of **Forever Flex™** or **Armor Flex™** lining systems is dependent on the use of parts and materials specified in these instructions. Substitution of unauthorized parts may increase the risk of fire, appliance malfunction, property damage, personal injury or death. All installations must be in accordance with local codes, NFPA 211 standards, and/or the National Building Code of Canada, and the manufacturer's instructions.

# Reference Diagrams for: Chimney Connector Systems and Clearances from Combustible Walls for Residential Heating Appliances

(Reprinted with the permission of the National Fire Protection Association, NFPA 211, 2000 edition)

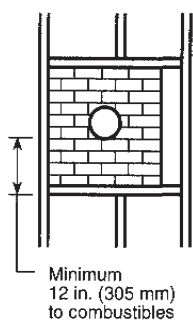

Minimum chimney clearance to brick and combustibles 2 in. (51 mm)

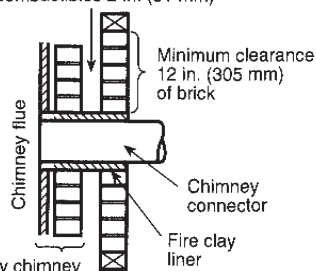

Masonry chimney constructed to NFPA 211

Minimum chimney clearance from masonry to sheet steel supports and combustibles 2 in. (51 mm)

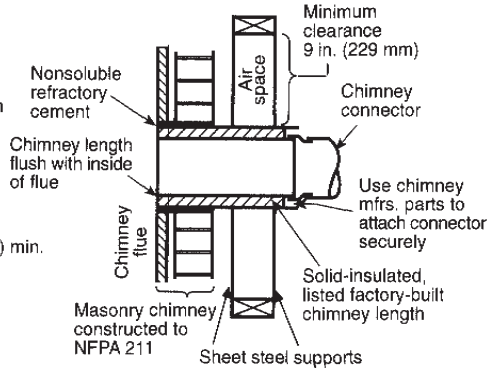
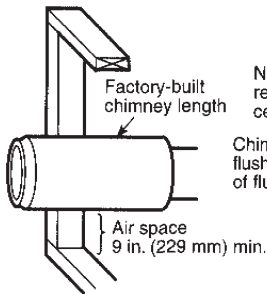

## System

Clearance (in.)/(mm)

- A Minimum 3.5-in. (90-mm) thick brick masonry wall framed into combustible wall with a minimum of 12-in. (305-mm) brick separation from clay liner to combustibles. Fireclay liner (ASTM C 315, *Standard Specification for Clay Fire Linings*, or equivalent), minimum 5/8-in. (16-mm) wall thickness, shall run from outer surface of brick wall to, but not beyond, the inner surface of chimney flue liner and shall be firmly cemented in place. 12/305

- B Solid-insulated, listed factory-built chimney length of the same inside diameter as the chimney connector and having 1 in. (25.4 mm) or more of insulation with a minimum 9-in. (229-mm) air space between the outer wall of the chimney length and combustibles. 9/229

The inner end of the chimney length shall be flush with the inside of the masonry chimney flue and shall be sealed to the flue and to the brick masonry penetration with non-water-soluble refractory cement. Supports shall be securely fastened to wall surfaces on all sides.

Fasteners between supports and the chimney length shall not penetrate the chimney liner.

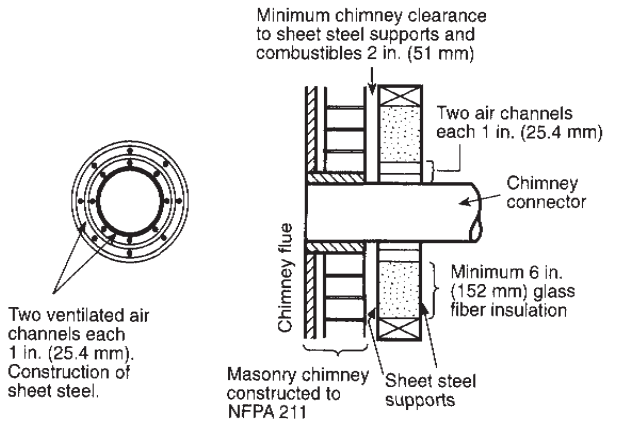

C Sheet steel chimney connector, minimum 24 gauge [0.024 in. (0.61 mm)] in thickness, with a ventilated thimble, minimum 24 gauge [0.024 in. (0.61 mm)] in thickness, having two 1-in. (25.4-mm) air channels, separated from combustibles by a minimum of 6 in. (152 mm) of glass fiber insulation. Opening shall be covered, and thimble supported with a sheet steel support, minimum 24 gauge [0.024 in. (0.61 mm)] in thickness. Supports shall be securely fastened to wall surfaces on all sides and shall be sized to fit and hold chimney section. Fasteners used to secure chimney section shall not penetrate chimney flue liner.

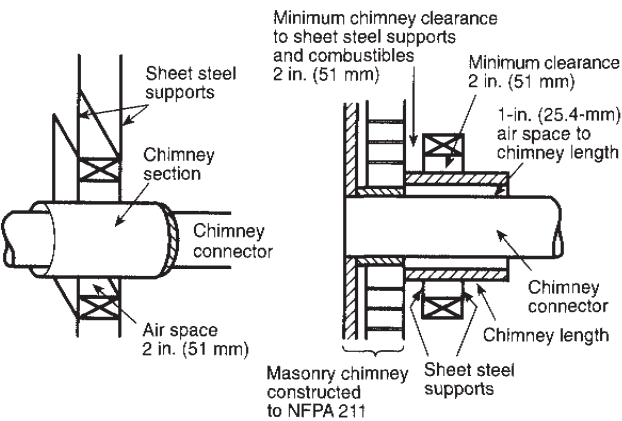

D Solid-insulated, listed factory-built chimney length with an inside diameter 2 in. (51 mm) larger than the chimney connector and having 1 in. (25 mm) or more of insulation, serving as a pass-through for a single wall sheet steel chimney connector of minimum 24 gauge [0.024 in. (0.61 mm)] thickness, with a minimum 2-in. (51-mm) air space between the outer wall of chimney section and combustibles. Minimum length of chimney section shall be 12 in. (305 mm). Chimney section concentric with and spaced 1 in. (25.4 mm) away from connector by means of sheet steel support plates on both ends of chimney section. Opening shall be covered, and chimney section supported on both sides with sheet steel supports of minimum 24 gauge [0.024 in. (0.61 mm)] thickness. Supports shall be securely fastened to wall surfaces on all sides and shall be sized to fit and hold chimney section. Fasteners used to secure chimney section shall not penetrate chimney flue liner.

**Additional requirements:**

1. Insulation material used as part of wall pass-through system shall be of noncombustible material and shall have a thermal conductivity of 1.0 Btu-in./hr-ft<sup>2</sup>-°F (4.88 kg-cal/hr-m<sup>2</sup>-°C) or less.
2. All clearances and thicknesses are minimums; larger clearances and thicknesses shall be permitted.
3. Any material used to close up an opening for the connector shall be of noncombustible material.
4. A connector to a masonry chimney, except for System B, shall extend in one continuous piece through the wall pass-through system and the chimney wall to the inner face of the flue liner, but not beyond.

# Maintenance Instructions

**The lining system must be installed and serviced by a qualified chimney or venting professional.** The criteria for the inspection and maintenance must be in conformance with local or state building codes, whichever has jurisdiction. It is recommended you use an inspection form and make notes that you can review with the homeowner.

## **Warning For Solid Fuel Applications**

“Creosote and Soot-Formation and Need for Removal: When wood is burned slowly, it produces tar and other organic vapors, which combine with expelled moisture to form creosote. The creosote vapors may condense on the inside of the chimney liner during slow-burning firing periods. As a result, creosote residue accumulates on the chimney liner. When ignited, this creosote makes an extremely hot fire.

The chimney liner system should be inspected at least once every two months during the heating season to determine if a creosote or soot buildup has occurred.

If creosote or soot has accumulated, it should be removed to reduce the risk of a chimney fire.”

## **Maintenance Procedures**

**It is important that the chimney lining system be checked and cleaned annually.** This is for the safety of the homeowner and necessary to meet the warranty requirements of **FOREVER FLEX™ AND ARMOR FLEX™**. As noted above in the case of solid fuel burning appliances more frequent maintenance may be required, depending on use. The entire system, from the connection at the appliance to the top of the liner, must be completely inspected and cleaned.

To clean the chimney lining system it is recommended to perform the following:

- 1) Remove cap
- 2) Select the proper sized nylon, poly or natural bristle chimney brush to clean the liner. Steel brushes may be used on Armor Flex only. Be sure the brush head passes throughout the complete length of the liner, including the connectors, terminals and tees.
- 3) In some instances, proper cleaning will require removing the appliance and disassembling the connector assembly to thoroughly inspect and clean parts that cannot be reached otherwise.
- 4) Inspect and clean the chimney cap. Spark arrestors and other screens may be necessary or required in some areas, but may be susceptible to blockage from creosote or through freezing moisture in areas of low ambient temperature.
- 5) Reinstall chimney cap.
- 6) Before the initial firing of the appliance, check the appliance’s operating instructions for initial firing precautions.

## **Additional Information**

- 1) **FOREVER FLEX™ AND ARMOR FLEX™** lining systems are intended for use with heating appliances, burning home heating oil, natural or LP gas and solid fuels (pellet, wood, and coal). Use of experimental fuels is not permitted and voids warranty.
- 2) Use only components listed for use with the **FOREVER FLEX™ AND ARMOR FLEX™** lining system.
- 3) For solid-fuels, the chimney liner is not to be sized less than that specified in the appliance manufacturer’s instructions.
- 4) If not in place, post notices near the point where the connection is made to the gas vent or roof jack, concerning limitations to use with either gas or gas and oil appliances only, when a liner is for use with either gas or gas and oil fuel only.

**Olympia Chimney Supply, Inc.  
600 Sanders St., Scranton, PA 18505  
1-800-569-1425**

# MAINTENANCE RECORD

After each annual inspection, maintenance and cleaning, have your chimney sweep or installer fill out and date the appropriate section of this sheet. Remember – *Receipts verifying the annual maintenance was performed must also be retained.* Once this sheet has been filled, maintain your own similar record of the required inspection, maintenance and cleaning.

Name (Homeowner) \_\_\_\_\_ Address \_\_\_\_\_  
 City \_\_\_\_\_ State \_\_\_\_\_ Zip \_\_\_\_\_ Installation Date \_\_\_\_\_

Installer \_\_\_\_\_  
 Phone \_\_\_\_\_  
 Company \_\_\_\_\_  
 Address \_\_\_\_\_  
 City \_\_\_\_\_ State \_\_\_\_\_ Zip \_\_\_\_\_

## Record of Annual Cleaning and Inspection

Sweep/Installer: _____ Work Done: _____ Date: _____	Sweep/Installer: _____ Work Done: _____ Date: _____	Sweep/Installer: _____ Work Done: _____ Date: _____
Sweep/Installer: _____ Work Done: _____ Date: _____	Sweep/Installer: _____ Work Done: _____ Date: _____	Sweep/Installer: _____ Work Done: _____ Date: _____
Sweep/Installer: _____ Work Done: _____ Date: _____	Sweep/Installer: _____ Work Done: _____ Date: _____	Sweep/Installer: _____ Work Done: _____ Date: _____
Sweep/Installer: _____ Work Done: _____ Date: _____	Sweep/Installer: _____ Work Done: _____ Date: _____	Sweep/Installer: _____ Work Done: _____ Date: _____
Sweep/Installer: _____ Work Done: _____ Date: _____	Sweep/Installer: _____ Work Done: _____ Date: _____	Sweep/Installer: _____ Work Done: _____ Date: _____
Sweep/Installer: _____ Work Done: _____ Date: _____	Sweep/Installer: _____ Work Done: _____ Date: _____	Sweep/Installer: _____ Work Done: _____ Date: _____
Sweep/Installer: _____ Work Done: _____ Date: _____	Sweep/Installer: _____ Work Done: _____ Date: _____	Sweep/Installer: _____ Work Done: _____ Date: _____

# LIMITED **FOREVER WARRANTY**™

316Ti, 316L, 304L or AL 29-4C Alloy Stainless Steel Relining Pipe for Solid Fuels (Wood, Coal, and Pellet), Oil, and Category I Gas Appliance Applications

## **Limited Warranty Coverage**

Olympia Chimney Supply, Inc warrants to you (the “purchaser”) that for the period set forth below, the **FOREVER FLEX™**, **ARMOR FLEX™** or **RHINO RIGID™** stainless steel relining pipe and components when used as a chimney relining pipe, in a masonry chimney, exclusively for residential appliances, shall be free from defects in material or manufacturer’s workmanship; and from perforation caused by chimney fire or over firing by you (the “purchaser”).

## **Warranty Period**

The benefits of this warranty shall apply to you (the “purchaser”) **FOREVER** with no time limit, provided that you continue to own your own home where the **FOREVER FLEX™**, **ARMOR FLEX™** or **RHINO RIGID™** is installed. (Note: \*A) In all events, even if you sell your home, Olympia Chimney Supply, Inc will honor the warranty **FOREVER** with no time limit so that even a new owner will benefit from the installation in your home.

## **Warranty Period (304L Forever Flex)**

The benefit of this warranty shall apply to you (the “purchaser”) one hundred percent (100%) of the purchase price for 15 years from the date of purchase, and fifty percent (50%) thereafter. This warranty is non-transferable.

## **Warranty Conditions and Limitations**

The **FOREVER FLEX™**, **ARMOR FLEX™** or **RHINO RIGID™** warranty is subject to the following conditions: 1) installation of the pipe and components must be in accordance with the manufacturer’s written instructions; 2) the product must be used only for the lining or relining of chimney’s used to vent residential appliances; 3) use of this pipe for venting gas appliances is limited to Category I appliances; 4) the **FOREVER FLEX™**, **ARMOR FLEX™** or **RHINO RIGID™** lining system must be cleaned and inspected on an annual basis by an experienced chimney professional, (i.e., at intervals of no more than 18 months each, commencing from the date of purchase), who must fill out and date the appropriate section on this warranty card upon completion of such yearly maintenance. *Receipts verifying the annual maintenance was performed must also be retained*; 5) corrosive chemical chimney cleaners must not be used; 6) driftwood, wood, or wood pellets containing salt, preservative treated lumber, plastic, experimental fuels, and household trash must not be burned in the appliance; 7) Plastic bristle flue-cleaning brushes are recommended; 8) in the case of a chimney fire, the chimney must be inspected and approved by an experienced and qualified chimney professional, according to Olympia Chimney Supply’s maintenance instructions before reuse; 9) the chimney must have a cap or slate covering installed.

## **Claim Process and Limitations of Liability**

You may make a claim under this warranty by giving notice to your chimney professional and having your chimney professional provide information about the claim to Olympia Chimney Supply. Upon approval of your claim, Olympia Chimney Supply shall provide new **FOREVER FLEX™**, **ARMOR FLEX™** or **RHINO RIGID™** pipe and components to you as your exclusive remedy.

Olympia Chimney Supply, Inc does not assume any liability or responsibility for faulty installation of the liner or components, or for defective materials not supplied by it.

Neither Olympia Chimney Supply nor the installer of the **FOREVER FLEX™**, **ARMOR FLEX™** or **RHINO RIGID™** lining system shall be liable for any removal or installation charges or for any special, incidental, or consequential damages in any way related to, the **FOREVER FLEX™**, **ARMOR FLEX™** or **RHINO RIGID™** pipe. This warranty gives you specific legal rights, and you may also have other rights, which vary from state to state. Some states do not allow the exclusion or limitations of incidental or consequential damages, so the above limitations or exclusions may not apply to you.

\* A: Excludes 304L Forever Flex