

**ThermoBloc™ boiler protection recirculation and distribution unit**

© Copyright 2013 Caleffi

**281 Series**

**Installation, commissioning and servicing instructions**

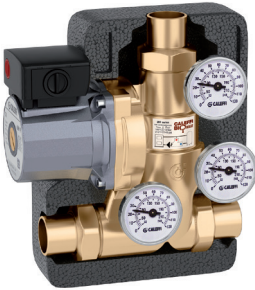

**Function**

The ThermoBloc™ boiler protection recirculation and distribution unit is used in hydronic heating systems with non-condensing boilers, including solid fuel, biomass, gas LP or oil-fired. It can be installed with steel, cast iron and copper tube style boilers, automatically controlling the return water temperature, protection against corrosion from condensation occurring when a minimum flue gas temperature is not otherwise maintained. The ThermoBloc™ unit is compact for easy installation, reducing required space and fittings. It combines the functionality of a boiler protection valve with a circulation pump and a unique flapper check valve allowing for thermosyphon flow between the boiler and distribution system during a power outage. The ThermoBloc™ includes three temperature gauges and is encased in an insulation shell.

**Product range**

281 series boiler protection recirculation and distribution unit. NPT male or sweat, sizes 1", 1-1/4".

**Technical Characteristics**

- Materials:
  - Body: brass
  - Shutter: PSU
  - Spring: stainless steel
  - Flapper check valve: PPS
  - Seal: EPDM
  - Thermostatic sensor: wax
- Suitable fluids: water, up to 50% glycol solutions
- Max working pressure: 150 psi (10 bar)
- Working temperature range: 40-210°F (5-100°C)
- Temperature gauge scale: 30-250°F (0-120°C)
- Thermostatic sensor cartridge: 130°F (55°C) standard  
115°F (45°C), 140°F (60°C),  
160°F (70°C) optional cartridges
- Sensor cartridge accuracy: ±3.6°F (±2°C)
- Bypass from boiler complete closing temperature: Tset +18°F (10°C)
- Connections:
  - NPT male union: 1" and 1-1/4"
  - sweat union: 1" and 1-1/4"

**Pump**

- Three speed pump: Wilo Star S-16 U15
- Body: cast iron
- Power supply: 115 V - 60 Hz
- Max. pressure: 85 psi (6 bar)
- Max. temperature: 230°F (110°C)
- Agency approval: cULus

## Pump characteristics

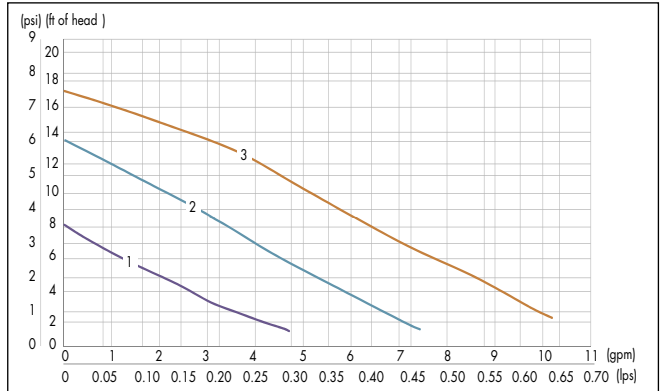

## Insulation

Material:	EPP
Mean thickness:	30 mm
Density:	45 kg/m <sup>3</sup>
Working temperature range:	40-210°F (5-100°C)
Thermal conductivity:	0.037 W/(m.K) at 10°C
Reaction to fire (UL94):	class HBF



### SAFETY INSTRUCTION

This safety alert symbol will be used in this manual to draw attention to safety related instructions. When used, the safety alert symbol means **ATTENTION! BECOME ALERT! YOUR SAFETY IS INVOLVED! FAILURE TO FOLLOW THESE INSTRUCTIONS MAY RESULT IN A SAFETY HAZARD.**



**CAUTION:** All work must be performed by qualified personnel trained in the proper application, installation, and maintenance of systems in accordance with all applicable codes and ordinances.



**CAUTION:** If the boiler protection unit is not installed, commissioned and maintained properly, according to the instructions contained in this manual, it may not operate correctly and may endanger the user.



**CAUTION:** Make sure that all the connecting pipework is water tight.



**CAUTION:** When making the water connections, make sure that the boiler protection unit connecting pipework is not mechanically over-stressed. Over time this could cause breakages, with consequent water losses which, in turn, could cause harm to property and/or people.



**CAUTION:** Water temperatures higher than 100°F can be dangerous. During the installation, commissioning and maintenance of the boiler protection unit, take the necessary precautions to ensure that such temperatures do not endanger people.



**CAUTION:** In the case of highly aggressive water, arrangements must be made to treat the water before it enters the boiler protection valve, in accordance with current legislation. Otherwise the boiler protection unit may be damaged and will not operate correctly.

**Leave this manual for the user.**

## Operation/Use

The thermostatic sensor, completely immersed in the medium, controls the movement of a shutter that regulates the bypass flow from the boiler and toward the system. At boiler startup, the boiler protection recirculation and distribution unit recirculates the bypass flow from the boiler to bring the boiler up to temperature as quickly as possible. When the bypass flow from the boiler exceeds the setting of the fixed thermostatic sensor, the unit's return from the system port starts opening to produce the water mixing temperature: in this phase the system loading begins.

When the mixed flow to the boiler temperature is greater than the set point of the boiler protection recirculation and distribution unit by approximately 18°F (10°C), the bypass flow from the boiler port closes and water returns to the boiler at the same temperature as the return flow from the system.

When power is out and the circulation pump stops running, the flapper check valve, which is closed during normal operation, opens with a slight pressure differential resulting from the effects of heated water in the boiler and cooler water in the distribution system, a natural thermosyphon flow. This prevents an excessive heat buildup which eventually would cause the pressure relief valve to open.

The compact brass body casting houses the pump and all functioning components, offering easy installation, either on the right or left side of the boiler. The temperature gauges can be easily removed and re-inserted on the back side of the unit.

The brass body prevents the formation of ferrous residues in the system, prolonging boiler operating life.

The unit features a thermostatic sensor to control the temperature of water returning to the boiler to prevent condensation. The sensor can be easily replaced for maintenance or set point change.

## Natural circulation flapper check valve

The flapper check valve allows the natural thermosyphon circulation of the system heat transfer fluid when the pump stops running due to power failure. When the pump is running under normal conditions the thrust of the flowing medium keeps the flapper closed, forcing flow past the thermostatic sensor. When the pump stops running and the fluid in the boiler is at high temperature, natural circulation begins, by-passing the thermostatic sensor, preventing over heating in the boiler.

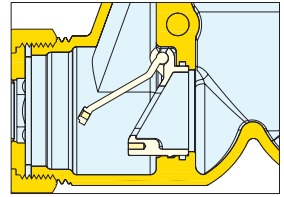

## Flapper check valve – lock

Before installation, remove the screw that keeps the flapper check valve closed. This screw is factory-installed to prevent breakage during shipment. Removing the protective screw ensures full functionality of the flapper check valve as a natural circulation device. To do this, unscrew the union located on the mixed water outlet port (to boiler) and access the screw inside the valve body, unscrewing it using a phillips head screwdriver.

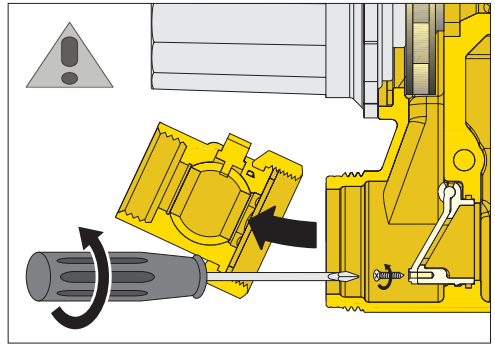

## Installation

The ThermoBloc™ boiler protection recirculation and distribution unit can be installed on both sides of the boiler following the flow directions indicated on the body. Installation is recommended on the return to the boiler in mixing mode, in vertical position (axis of the pump horizontal and the axis of the thermostatic sensor vertical). This allows for the proper functionality of the natural circulation flapper check valve. Separately purchased ball valves (Caleffi code NA39753- 1" FNPT or NA39588- 1-1/4" FNPT) installed on each inlet and the mixed flow outlet are highly recommended for isolation and maintenance.

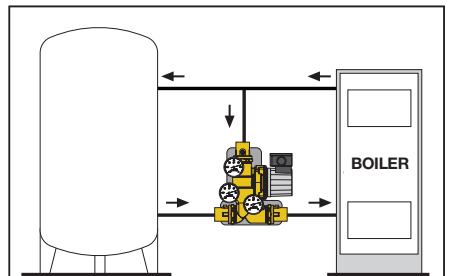
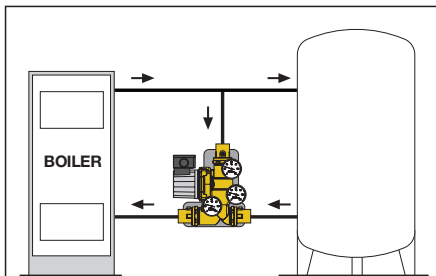
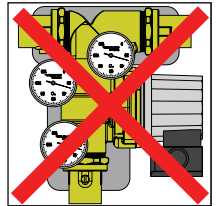
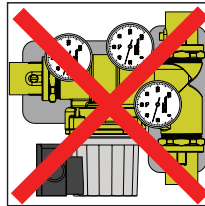
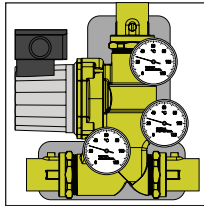

## Maintenance/Temperature setting field change out

To remove the thermostatic sensor for maintenance or field change out of thermostatic sensor cartridge, proceed as follows, paying attention to the position of each component:

- 1) Remove the insulation and the temperature gauges, shut off the three separately-purchased ball valves and remove the unit body from the pipes.
- 2) Using a 17 mm hex key, unscrew and extract the shutter locking nut, entering through the upper by-pass from boiler port on the unit (fig. 1).
- 3) Extract the spring: attached to it are the shutter and the thermostatic sensor (fig. 2).
- 4) Conduct appropriate maintenance or replace the thermostatic sensor with a new cartridge, separately purchased. The sensor can be fully inserted into the seat with a slight interference fit.
- 5) Reassemble the shutter unit following the procedure in reverse order.

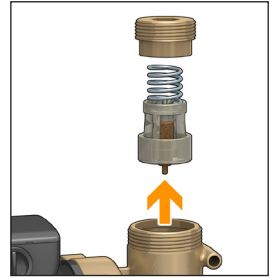
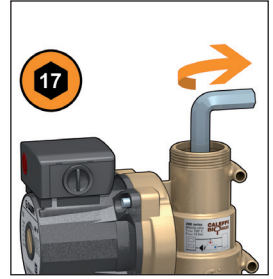

## Replacement parts and accessories



Replacement thermostatic sensor cartridges. Easy replacement to change the ThermoBloc™ boiler protection recirculation and distribution unit set temperature:

**F29633** 115°F (45°C)

**F29634** 130°F (55°C)- standard factory-supplied setting

**F29635** 140°F (60°C)

**F29636** 160°F (70°C)



Replacement pump. Easy replacement by removing 2 bolts and inserting the head in the 281 assembly.

**F19379** 115 VAC / .8 A. 16 feet head



**R50057** Replacement 1-1/2" union washer.



Dual scale temperature gauge for ThermoBloc™ boiler protection recirculation and distribution unit:

**F29571** 32 - 250°F (0 - 120°C)



**Caleffi North America, Inc.**  
**3883 W. Milwaukee Road**  
**Milwaukee, WI 53208**  
**T: 414.238.2360 F: 414.238.2366**