

# JØTUL

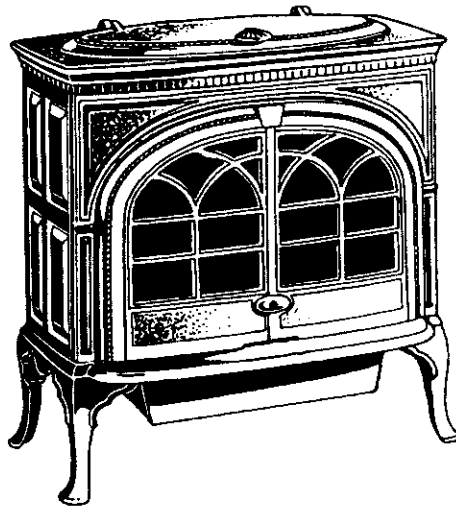

IAS Report No. L2156003

## FIRELIGHT Vented Gas Fireplace Installation and Operation Instructions

**WARNING: IF THE INFORMATION IN THIS MANUAL IS NOT FOLLOWED EXACTLY, A FIRE OR EXPLOSION MAY RESULT CAUSING PROPERTY DAMAGE, PERSONAL INJURY OR LOSS OF LIFE.**

Do not store or use gasoline or other flammable vapors and liquids in the vicinity of this or any other appliance.

What to do if you smell gas:

- DO NOT light any appliance.
- DO NOT touch any electrical switches.
- DO NOT use any phone in your building.
- Immediately call your gas supplier from a neighbor's phone.
- If your gas supplier cannot be reached, call the fire department.

Installation and service must be performed by a qualified installer, service agency or the gas supplier.

**WARNING: IMPROPER INSTALLATION, ADJUSTMENT, ALTERATION, SERVICE, OR MAINTENANCE CAN CAUSE INJURY OR PROPERTY DAMAGE. REFER TO THIS MANUAL FOR ASSISTANCE OR ADDITIONAL INFORMATION CONSULT A QUALIFIED INSTALLER, SERVICE AGENCY OR THE GAS SUPPLIER.**

**WARNING: THE FIRELIGHT IS A VENTED GAS FIREPLACE. DO NOT BURN WOOD OR OTHER MATERIAL IN THESE APPLIANCES.**

**WARNING: AT THE BEGINNING OF EACH HEATING SEASON HAVE THE DOOR GASKET INSPECTED FOR PROPER SEALING BY A QUALIFIED SERVICE TECHNICIAN. DUE TO HIGH TEMPERATURES, THE APPLIANCE SHOULD BE LOCATED OUT OF TRAFFIC AND AWAY FROM FURNITURE OR DRAPES. DO NOT PLACE CLOTHING OR OTHER MATERIALS ON OR NEAR THE APPLIANCE.**



Manufactured and Distributed by JØTUL USA  
*Installer-Please leave this manual with user of stove.*

## TABLE OF CONTENTS

Introduction .....	page 2
General Information .....	page 2
Location .....	page 3
Special Location Considerations .....	page 3
Clearances .....	page 3
Appliance Specifications .....	page 4
Appliance Clearances .....	page 4
Exterior Vent Clearances .....	page 5
Vertical Venting .....	page 6
Gas Vent Rule .....	page 6
Horizontal Venting .....	page 6
Installation Steps .....	page 6
Installation .....	page 6
Vent Chart .....	page 7
Direct Vent Installation .....	page 8
Vertical Termination .....	page 10
Connecting the Gas Line .....	page 11
High Elevation Derating .....	page 11
Installing Logs .....	page 12
Appliance Operation .....	page 12
Burner Adjustments .....	page 13
Firelight Series Options .....	page 13
Gas Conversion Kits .....	page 14
Operation/Care of Your Appliance .....	page 15
Maintenance .....	page 15
Gasket Inspection .....	page 15
Replacement Parts .....	page 15
Accessories/Components .....	page 16
Troubleshooting Guide .....	page 17
Lighting Instructions .....	page 18
Parts List .....	page 20

This installation and operation manual will help you obtain a safe, efficient, dependable installation for your vented gas fireplace. Please read and understand these installation instructions before beginning your installation.

### INTRODUCTION

The JØTUL Firelight is a sealed combustion, air circulating gas appliance designed for residential applications. This appliance must be installed with Duravent 6 3/8" x 4" vent systems routed to the outside atmosphere.

The JØTUL Firelight is designed to operate with either natural or propane gas. A millivolt gas control valve with piezo ignition system provides safe, efficient operation. External electrical power is required to operate the optional blower if installed in these units.

This appliance complies with National Safety Standards and is tested and listed by IAS (Report No. L 2156003) to ANSI Z21.88 (previously ANSI Z21.44), (In Canada, CAN/CGA-2.33) as a vented gas fireplace. This appliance is AFUE rated.

Installation must conform to local codes. Your dealer has been specifically selected to carry JØTUL stoves for his knowledge of local codes, and can provide assistance in making sure your installation is safe and legal.

In the absence of local codes, installation must comply with the current National Fuel Gas Code, ANSI Z223.1. (In Canada, the current CAN-1 B149 installation code.) Electrical wiring must comply with the National Electrical Code, ANSI/NFPA No. 70-latest edition. (In Canada, the current CSA C22.2 Canadian Electrical Code.) Approved for Mobile Home installation.

**DO NOT ATTEMPT TO ALTER OR MODIFY THE CONSTRUCTION OR THE APPLIANCE OR ITS COMPONENTS. ANY MODIFICATION OR ALTERATION MAY VOID THE WARRANTY, CERTIFICATION AND LISTINGS OF THIS UNIT.**

### GENERAL INFORMATION

JØTUL is the world's largest manufacturer of solid fuel burning appliances and has been making cast iron wood and coal stoves since 1853. Your new JØTUL gas stove has inherited the benefits learned from more than 140 years of producing stoves. With proper care and operation, your new JØTUL will last many, many years.

### TYPICAL INSTALLATION

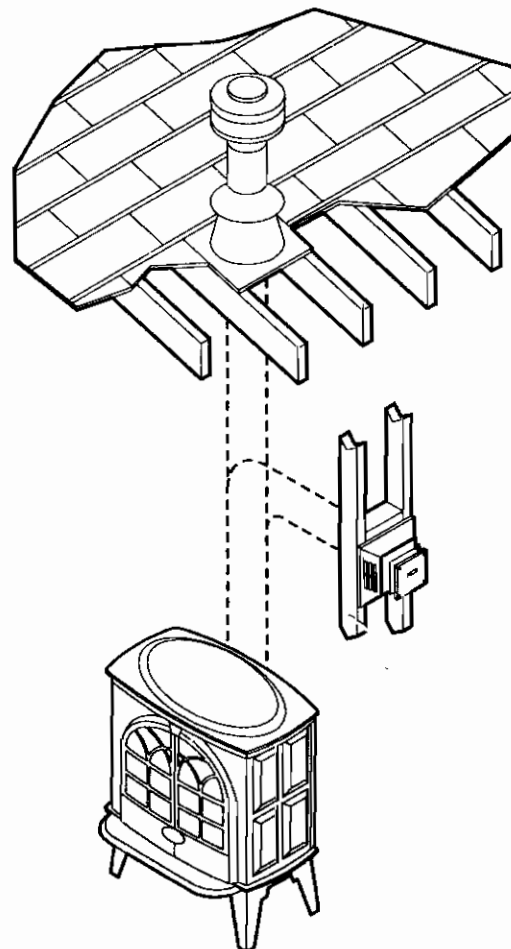

Figure 1

NOTE: DIAGRAMS & ILLUSTRATIONS NOT TO SCALE.

This JØTUL Firelight has been certified as a Vented Gas Fireplace. This Installation and Operation Manual provides the installation procedures and operating instructions for the Firelight. This gas stove is manufactured in compliance with nationally recognized standards, and has been certified by International Approval Service (formerly A.G.A.) for use in Canada and the United States.

**Note:** Installation and repair should be performed by a qualified service person. The appliance should be inspected annually by a qualified professional service person. More frequent inspections and cleanings may be required due to excessive lint from carpeting, bedding material, etc. It is imperative that the controls, burners and circulating air passage ways of the appliance be kept clean.

Provide adequate clearances around air openings and adequate accessibility clearance for service and proper operation. Never obstruct the front openings of the appliance.

This appliance is designed to operate on natural or propane gas only. The use of other fuels or combination of fuels will degrade the performance of this system and may be dangerous.

#### Appliance Input

	High Setting BTU/Hr	Low Setting BTU/Hr
Natural	42,000	34,000
Propane	38,000	32,000

Input of the JØTUL Firelight appliance is 42,000 BTU/Hr maximum modulated to 34,000 BTU/Hr at the low flame setting for natural gas. Input for propane models 38,000 BTU/Hr maximum modulated to 32,000 BTU/Hr at the low flame setting.

Do not use this appliance if any part of the gas valve or gas controls have been under water. Immediately call a qualified, professional service technician to inspect the appliance and to replace any parts of the control system and any gas control which have been under water.

Turn off gas to the appliance to extinguish the pilot flame at the beginning of each prolonged period of disuse.

The gage connections are provided on the front of the gas control valve (identified A for the manifold side and E for inlet pressure).

#### Inlet Gas Pressures (for the purpose of adjustment)

	MINIMUM (inches water column)	MAXIMUM (inches water column)
Natural	4.5	7.0
Propane	11	13.0

#### Manifold Gas Pressures

	MINIMUM (inches water column)	MAXIMUM (inches water column)
Natural	4.5	7.0
Propane	11	13.0

Minimum inlet gas pressure to the appliance is 4.5 inches water column for natural gas and 11 inches water column for propane for the purpose of input adjustment.

Maximum inlet gas supply pressure to the appliance is 7.0 inches water column for natural gas and 13.0 inches water column for propane.

The appliance must be isolated from the gas supply piping system (by closing its individual manual shut-off valve) during any pressure testing of the gas supply piping system at test pressures in excess of ½ psig (3.5 kPa).

The appliance and its individual shut-off valve must be disconnected from the gas supply piping system during any pressure testing of that system at pressure in excess of ½ psig (3.5 kPa).

This appliance must not be connected to a chimney or flue serving a separate solid fuel burning appliance.

In selecting the location, the aesthetic and functional use of the appliance are primary concerns. However, vent system routing to the exterior and access to the fuel supply are also important. Consideration should be given to traffic ways, furniture, draperies, etc., due to elevated surface temperatures. The location should also be free of electrical, plumbing or other heating/air conditioning ducting (Refer to Figure 2).

#### LOCATION

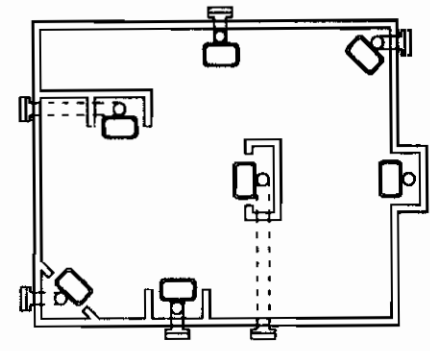

Typical Locations

Figure 2

**Note:** A three foot vertical rise is required before beginning a horizontal run.

The appliance should be mounted on a fully supported base extending the full width and depth of the unit. The appliance may be located on or near conventional construction materials. However, if installed on combustible materials, such as carpeting, vinyl tile, etc., provide floor protection under the appliance.

#### SPECIAL LOCATION CONSIDERATIONS

The JØTUL Firelight is approved for bedroom installation and manufactured (mobile) home installation. For mobile housing, refer to Title 24 CFR, Part 3280-Manufactured Home Construction and Safety Standard or CSA Z240.4 Gas Equipped Recreational Vehicles and Mobile Housing.

#### CLEARANCES

Minimum clearance to combustibles for the appliance is as follows: sides and back - 10", floor - 0" from bottom of legs, adjacent wall - 10", ceiling - 29" (Refer to Figures 6 and 7).

Minimum clearance to combustibles for the vent system is: horizontal run = top @ 3" (73 mm), sides @ 1" (25 mm), bottom @ 1" (25 mm), vertical run = 1" (25 mm) (Figure 7).

**\*Note:** For full open door presentation, a 12" minimum side clearance is required.

**WARNING: THIS HEATER MUST NOT BE INSTALLED DIRECTLY ON CARPET, NON-CERAMIC TILE OR OTHER COMBUSTIBLE MATERIAL, WITH THE EXCEPTION OF WOOD. IF IT IS DESIRED TO INSTALL THIS HEATER ON A CARPETED OR NON-CERAMIC TILED FLOOR, A METAL OR WOOD PANEL MUST BE PLACED UNDER THE HEATER THAT EXTENDS THE FULL WIDTH AND DEPTH OF THE HEATER.**

## SPECIFICATIONS

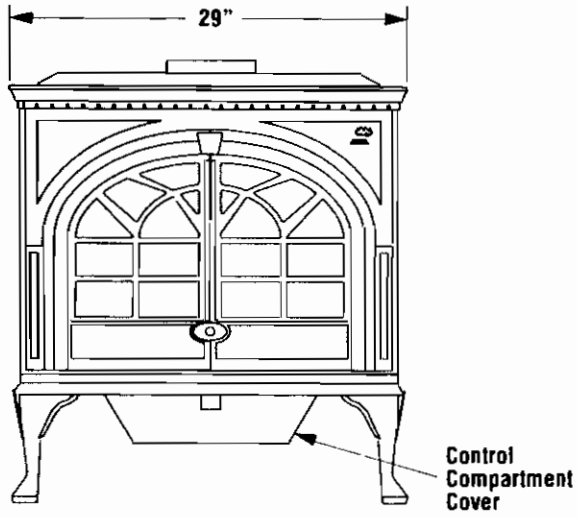

Figure 3

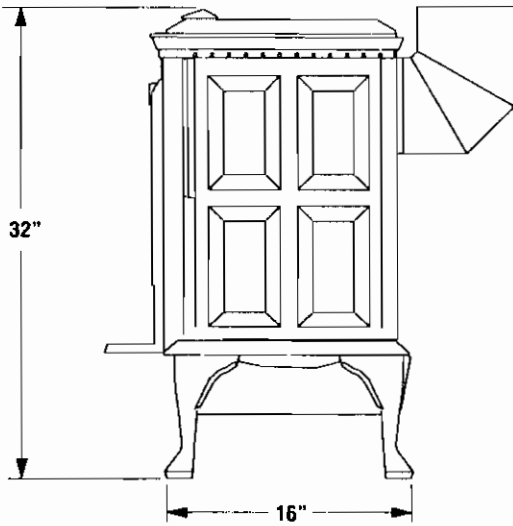

Figure 4

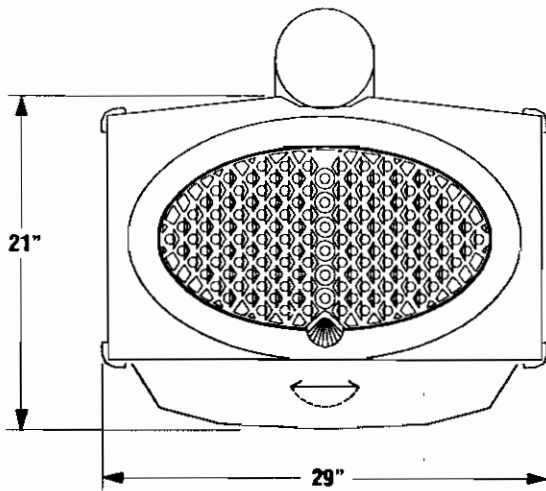

Figure 5

## CLEARANCES

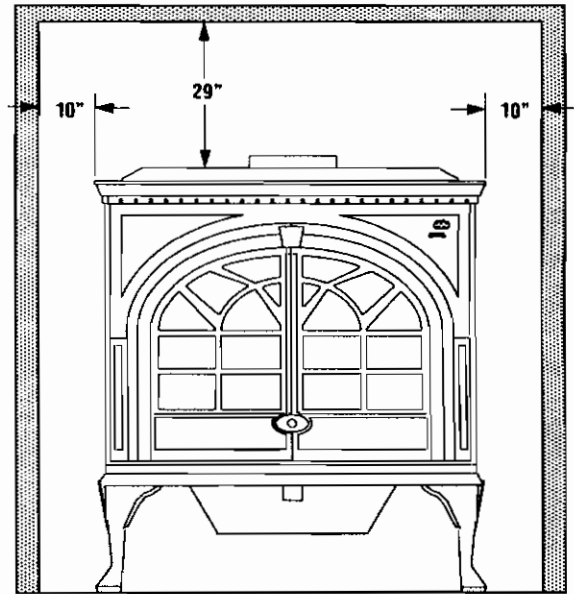

Figure 6

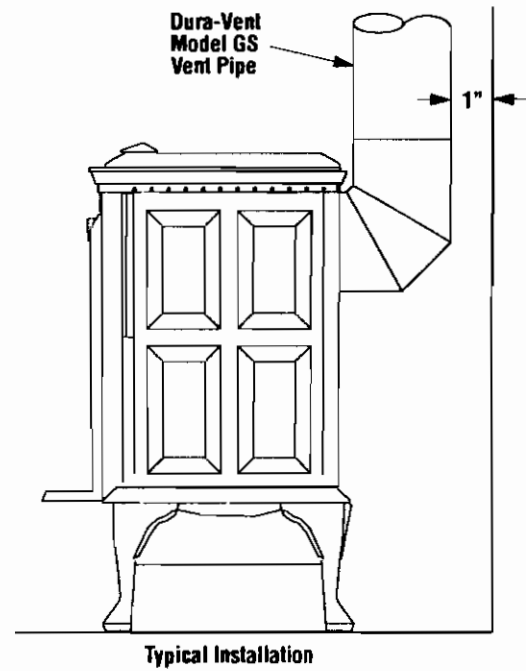
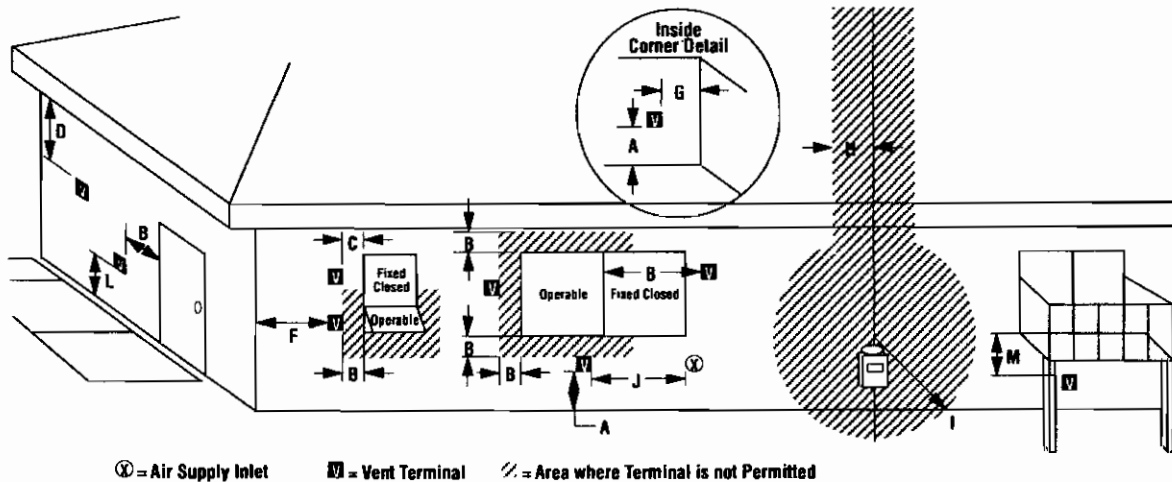

Figure 7

## EXTERIOR VENT CLEARANCE REQUIREMENTS



- |   |   |
|---|---|
| <p><b>A</b> = clearance above grade, veranda, porch, deck, or balcony<br/>12 inches (30 cm) minimum</p> <p><b>B</b> = clearance to window or door that may be opened<br/>U.S. - 9 inches (22.5 cm) minimum<br/>Canada - 12 inches (30 cm) minimum</p> <p><b>C</b> = clearance to permanently closed window - recommended to prevent condensation on window<br/>U.S. - 9 inches (22.5 cm) minimum<br/>Canada - 12 inches (30 cm) minimum</p> <p><b>D</b> = vertical clearance to soffit located above the terminal<br/>ventilated soffit 18 inches (46 cm) minimum<br/>unventilated soffit 12 inches (30 cm) minimum</p> <p><b>F</b> = clearance to outside corner<br/>9 inches (23 cm) minimum</p> <p><b>G</b> = clearance to inside corner<br/>6 inches (15.2 cm) minimum</p> <p><b>H</b> = not be installed above a gas meter/regulator assembly or within 3 feet (90 cm) horizontally from the center line of the regulator.</p> | <p><b>I</b> = clearance to gas service regulator vent outlet<br/>U.S. - 3 feet (90 cm) minimum<br/>Canada - 6 feet (1.8 m) minimum</p> <p><b>J</b> = clearance to air supply inlet to building or the combustion air inlet to any other appliance.</p> <p>non-mechanical inlet:<br/>US - 9 inches (22.5 cm) minimum<br/>Canada - 12 inches (30 cm) minimum</p> <p>mechanical air supply:<br/>6 feet (1.8 m) minimum</p> <p><b>L</b> = clearance above paved sidewalk or paved driveway located on public property<br/>7 feet (2.1 m) minimum</p> <p><b>Note:</b> A vent shall not terminate directly above a sidewalk or paved driveway which is located between two (2) single family dwellings and serves both dwellings.</p> <p><b>M</b> = clearance under veranda, porch, deck, or balcony where fully open on a minimum of two (2) sides beneath the floor<br/>12 inches (30 cm) minimum</p> |
|---|---|

**Note:** Check local codes or regulations for variations.

**Figure 8**

Roof Slope	Minimum Height from Roof to Lowest Discharge Opening
Flat to 6/12	1' 0"
Over 6/12 to 7/12	1' 3"
Over 7/12 to 8/12	1' 6"
Over 8/12 to 9/12	2' 0"
Over 9/12 to 10/12	2' 6"
Over 10/12 to 11/12	4' 0"
Over 11/12 to 12/12	5' 0"
Over 14/12 to 16/12	6' 0"
Over 18/12 to 20/12	7' 6"
Over 20/12 to 21/12	8' 0"

For SI units: 1 foot = 0.305 m

Table 1

### Vertical Venting

**Gas Vent Rule** – Gas vent caps that are located 8' or more from a portion of a building which extends at an angle greater than 45° upward from the horizontal may terminate in accordance with Table 1 (Figure 9), provided that in no case shall any discharge opening on the cap be less than 2' (610 mm) horizontally from the roof surface.

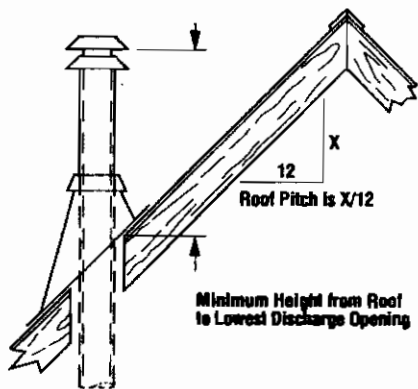

Figure 9

### Horizontal Venting

The vent termination must have a minimum of 3" (76 mm) clearance to any overhead combustible projection of 2 1/2" (64 mm) or less. Maintain 12" (305 mm) clearance from projections exceeding the 2 1/2" (64 mm) (Figure 10). For additional vent locations restrictions refer to Figure 8.

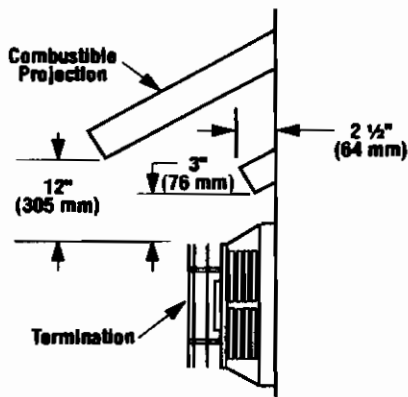

Figure 10

### INSTALLATION STEPS

The following sequence reflects a common installation process. Please note that each installation is unique, resulting in variations to those described.

1. Locate the appliance for best aesthetics and clearances.
2. Install handle, ash lip and other components detached for shipping.
3. Install the vent system.
4. Install optional remote control or wall thermostat, or wall switch.
5. Wire for the optional forced air blower kit.
6. Make connection to gas supply.
7. Install the logs.
8. Test fire the burner assembly, check pilot flame and main burner flame.
9. Adjust main burner characteristics.

### INSTALLATION

**Step 1.** Set the gas appliance in its desired location. Check to determine if wall studs or roof rafters are in the way when the venting system is attached. If this is the case, you may want to adjust the location of the appliance.

Slide the appliance away from the wall far enough to allow for the first section of vent pipe (see Figure 7.)

If the appliance is to be installed in a manufactured home, it must be secured to the floor. To secure the appliance to the floor use the floor bracket kit Part Number (04-950081) and proceed as follows:

A. Locate the raised boss areas on the bottom of the stove (Figure 11.)

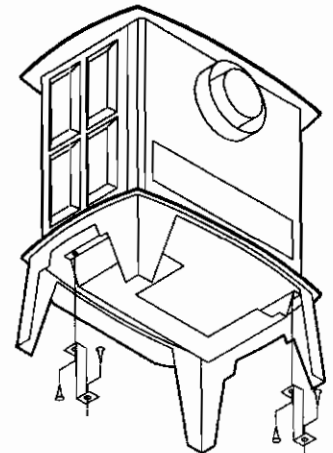

Figure 11

B. Attach one end of each of the brackets to the stove using the bolts provided with the kit.

C. Using the screws from the kit, attach the other end of each bracket to the floor.

There are two basic types of installations approved with JØTUL Firelight Model: Horizontal Termination (see Figure 12) Vertical Termination (see Figure 13).

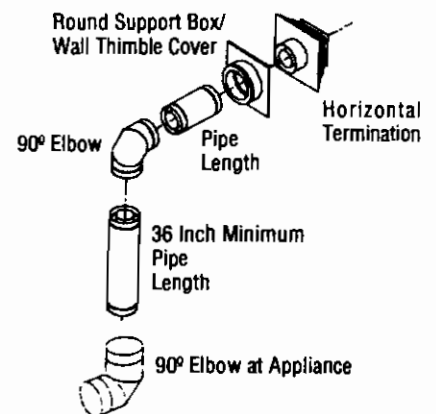
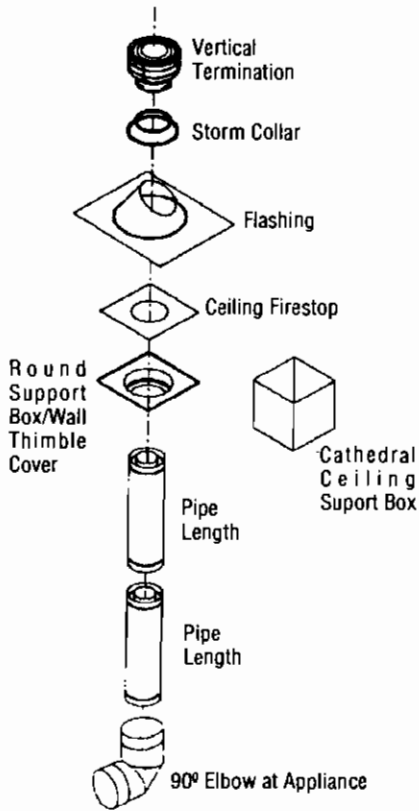
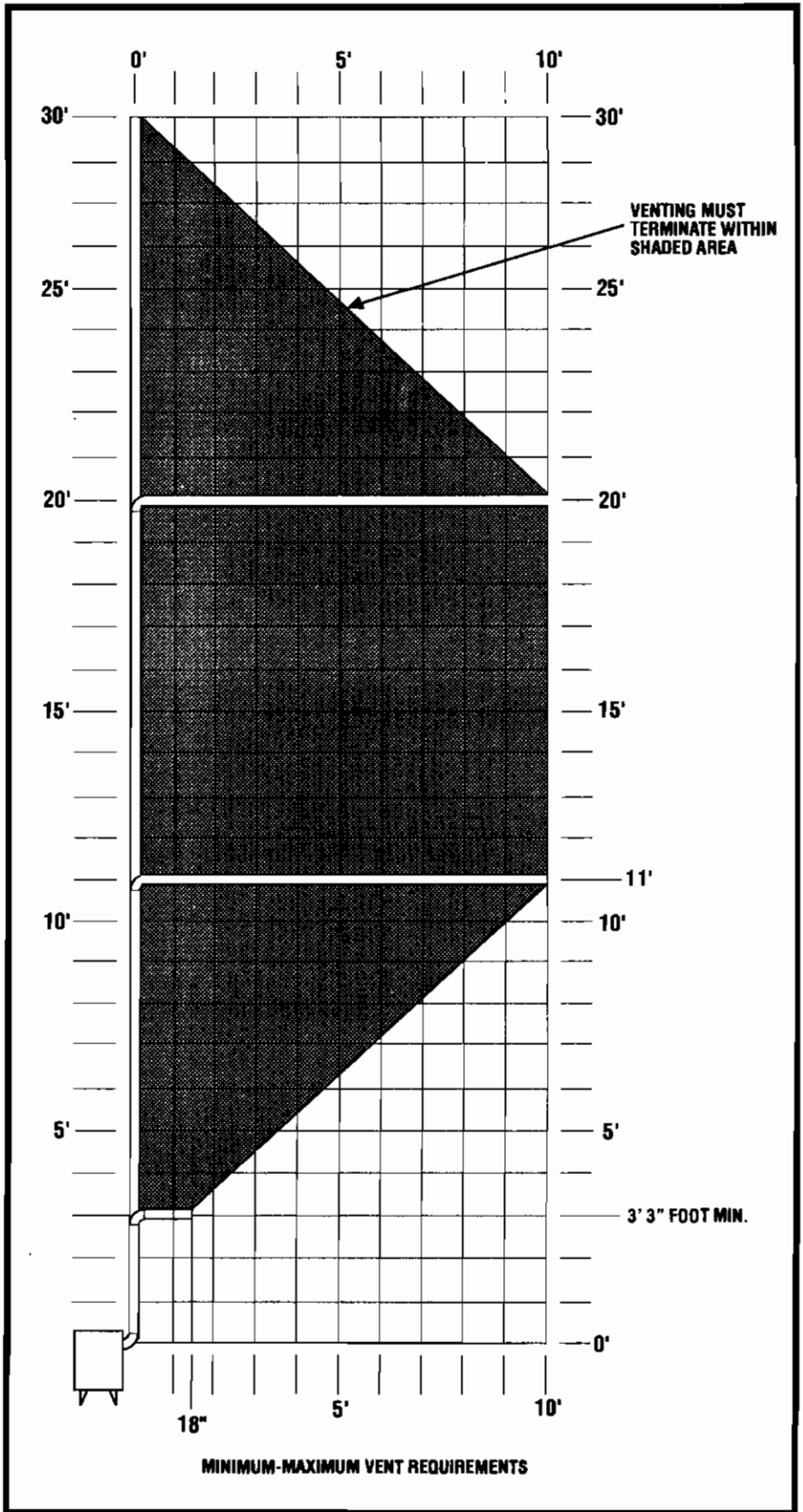

Figure 12



**Figure 13**

When planning your installation, refer to Table 2 to determine the specified limitations of your vent system. Total vent system must not exceed 30'. Also consult page 5, "Exterior Vent Clearance Requirements" regarding placement of the vent termination.



**Table 2**

NOTE: DIAGRAMS & ILLUSTRATIONS NOT TO SCALE.

**WARNING: THE CAST IRON TOP PLATE OF YOUR JØTUL FIRELIGHT DIRECT VENT GAS ROOM HEATER IS NOT FASTENED TO THE FRAME OF THE STOVE. THE WEIGHT OF THE TOP PLATE, WILL, HOWEVER, KEEP IT SECURELY IN PLACE DURING OPERATION OF THE STOVE. UNDER NO CIRCUMSTANCES SHOULD YOU OPERATE THE STOVE WITH THE TOP PLATE REMOVED.**

**Step 2.**

Your JØTUL Firelight Gas Room Heater requires some minor assembly before you can operate the stove.

When you receive your heater you should find the following components in the carton on the wooden pallet:

- Plastic bag containing a cast iron ash lip.
- Plastic bag containing:
  - Cast door handle
  - Touch-up paint
  - Allen wrench

Remove the plastic bag from the carton supplied with the heater. Remove the handle from the bag and insert its hex head into the hex of the door latch mechanism (see Figure 14).

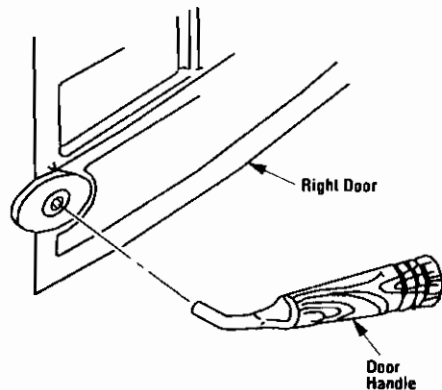

**Figure 14**

Remove the Ashlip Plate from the carton. Attach this to the front of the heater using the bolts which are already located in the threaded holes beneath the door (see Figure 15).

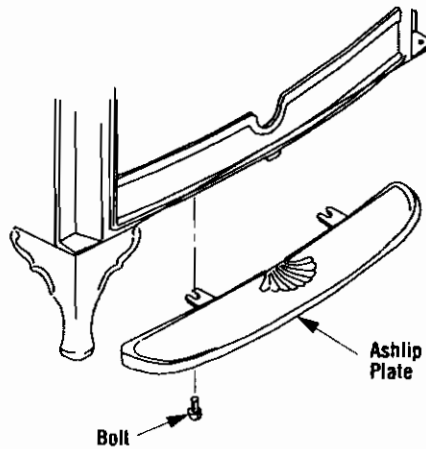

**Figure 15**

**DIRECT VENT INSTALLATION**

**Step 3.**

Your JØTUL Firelight has been shipped from the factory configured as a direct vent gas appliance to be installed with Dura-Vent direct vent components. The following paragraphs detail the vent installation procedure.

**Note:** The JØTUL Firelight model must be vented using Simpson Dura-Vent GS venting system. All warranties will be voided and serious fire, health or other safety hazards may result from any of the following actions: installation of any damaged components; unauthorized modification of vent system; installation of any components not manufactured or approved by JØTUL; failure to meet all clearance requirements; failure to properly twist lock and seal all components.

Each inner section of Dura-Vent must be properly sealed to prevent the possibility of leakage. This is accomplished by using a high temperature sealant (Milpack Black, Thermoseal 100 or equivalent). Apply a bead of sealant around the bell section of the inner pipe prior to joining the pieces together. The outer pipe joint may be sealed with metal foil tape or with an appropriate sealant.

**WARNING: ALWAYS MAINTAIN REQUIRED CLEARANCES (AIR SPACES) TO COMBUSTIBLES TO PREVENT A FIRE HAZARD. DO NOT FILL AIR SPACES WITH INSULATION. CHECK INSTALLATION INSTRUCTIONS FOR MINIMUM CLEARANCE REQUIREMENTS BETWEEN THE OUTER WALLS OF THE VENT PIPE AND NEARBY COMBUSTIBLE SURFACES. BE SURE TO CHECK THE VENT TERMINATION CLEARANCE REQUIREMENTS FROM DECK, WINDOWS, SOFFIT'S, GAS REGULATORS, AIR SUPPLY INLETS AND PUBLIC WALKWAYS, AS SPECIFIED IN THESE INSTALLATION INSTRUCTIONS AND LOCAL BUILDING CODES. (SEE PAGE 5). THE GAS APPLIANCE AND VENT SYSTEM MUST BE VENTED DIRECTLY TO THE OUTSIDE OF THE BUILDING, AND NEVER ATTACHED TO A CHIMNEY SERVING SEPARATE SOLID FUEL OR GAS BURNING APPLIANCES. EACH DIRECT VENT GAS APPLIANCE MUST HAVE ITS OWN SEPARATE VENT SYSTEM. COMMON VENT SYSTEMS ARE PROHIBITED.**

**Note:** Dura-Vent pipe fittings are designed with special twist-lock connections. Assemble the desired combination of pipe and elbows to the appliance with pipe seams oriented towards the wall or floor, as much out of view as possible.



Twist-lock procedure:

1. Four indentations, located on the female ends of pipes and fittings, are designed to slide straight onto the male ends of adjacent pipes and fittings, by orienting the four pipe indentations so they match and sliding into the four entry slots on the male ends (Figure 16). Push the pipe sections completely together, then twist-lock one section clockwise approximately one-quarter turn, until the two sections are fully locked.

2. Horizontal runs of vent must be supported every three feet. Wall straps are available for this purpose Dura Vent Part No. 988.

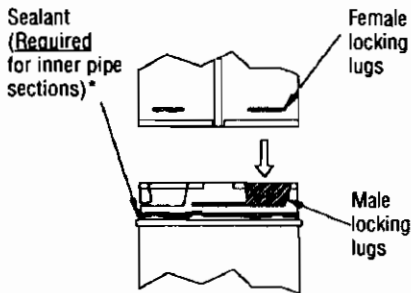

\* Note: Outer pipe joints may be optionally sealed.

Figure 16

A. The horizontal run of vent must be level, or have a 1/4" rise for every 1 foot of run toward the termination. Never allow the vent to run downward. This could cause high temperatures and may present the possibility of a fire.

B. For HORIZONTAL runs, a 3" top clearance (airspace) and 1" side and bottom clearance **MUST** be maintained with the Direct Vent pipe. For VERTICAL runs, a 1" clearance **MUST** be maintained with Direct Vent pipe.

C. With the pipe attached to the appliance, slide the appliance into its correct location, and mark the wall for a 10" x 10" square hole. The center of the square hole should line up with the centerline of the horizontal pipe as shown in Figure 17. Cut and frame the 10" square hole in the exterior wall where the vent will be terminated. Install the Wall Thimble (Dura Vent Part No. 942) into the frame opening. If the wall being penetrated is constructed of noncombustible material, i.e. masonry block or concrete, a 7" diameter hole is acceptable, and the Wall Thimble is not needed.

D. Position the horizontal vent termination into the wall thimble, and attach to the exterior wall with the four wood screws provided. Before attaching the Vent Termination Dura Vent Part No. 984, to the exterior wall, run a bead of non-hardening mastic around its outside edges, so as to make a seal between it and the wall. The arrow on the vent cap should be pointing up. Insure that proper clearances to combustible materials are maintained (Figure 18).

E. Before connecting the horizontal run of vent pipe to the vent termination, slide the black decorative wall thimble cover, Dura Vent Part No. 940, over the vent pipe.

F. Slide the appliance and vent assembly toward the wall, carefully inserting the vent pipe into the vent cap assembly. It is important that the vent pipe extended into the vent cap a sufficient distance so as to result in a minimum pipe overlap of 1-1/4 inches. Secure the connection between the vent pipe and the vent cap by attaching the two sheet metal strips extending from the vent cap assembly into the outer wall of the vent pipe. Use two sheet metal screws provided to connect the strips to the Pipe Section (Figure 19).

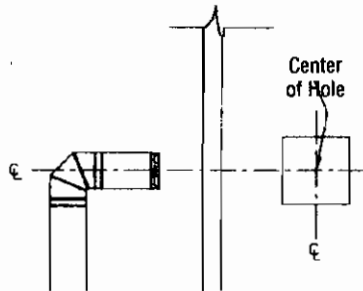

Figure 17

**Notes:**

1. The four wood screws provided should be replaced with appropriate fasteners for stucco, brick, concrete, or other types of sidings.

2. Venting termination shall not be recessed into a wall or siding. For buildings with vinyl sidings, a Vinyl Siding Standoff (Dura Vent Part No. 950) should be installed between the vent cap and the exterior wall (Figure 20). Attach the Vinyl Siding Standoff to the Horizontal Vent Termination. The Vinyl Siding Standoff prevents excessive heat from possibly melting the vinyl siding material.

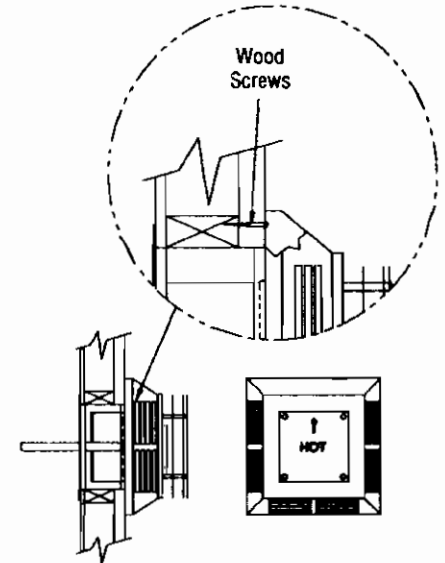

Figure 18

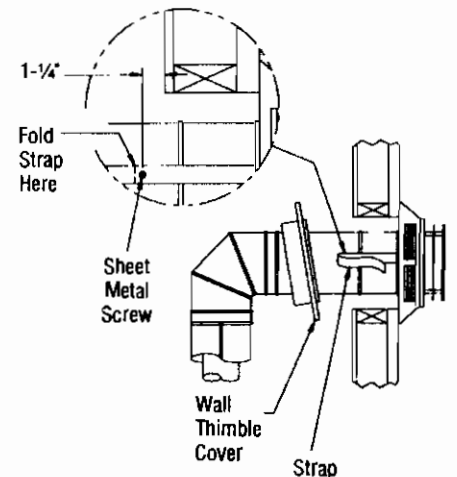

Figure 19

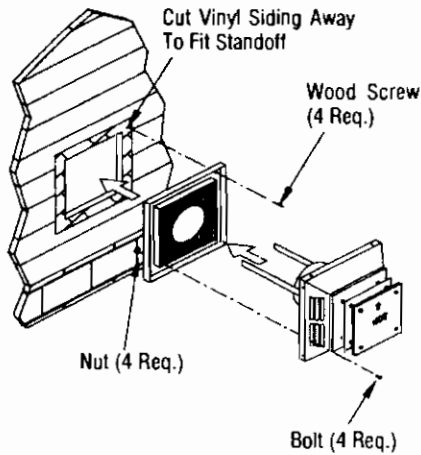

Figure 20

## VERTICAL TERMINATION

**A.** Set the gas appliance in its desired location. Drop a plumb bob down from the ceiling to the exit position of the first 90° elbow, and mark the location where the vent will penetrate the ceiling. Drill a small hole at this point. Next, drop a plumb bob from the underside of the roof to the hole previously drilled in the ceiling, and mark the spot where the vent will penetrate the roof. Determine if ceiling joists, roof rafters, or other framing will obstruct the venting system. You may wish to relocate the appliance, or to offset it, as shown in Figure 21, to avoid cutting load bearing members.

**B.** To install the Round Support Box/Wall Dura Vent Part No. 940, Thimble in a flat ceiling, cut a 10" square hole in the ceiling, centered on the hole drilled in Step A. Frame the hole as shown in Figure 22.

**C.** Assemble the desired lengths of Pipe and Elbows necessary to reach from the appliance adapter up through the Round Support Box. Insure that all Pipe and Elbow connections are in their fully twist-locked position.

**D.** Cut a hole in the roof centered on the small drill hole placed in the floor in Step A. The hole should be of sufficient size to meet the 1" requirements for clearance to combustibles. Continue to assemble lengths of Pipe and Elbows necessary to reach from the Round Support Box/Wall Thimble up through the roof line. Galvanized Pipe and Elbows may be utilized in the attic, as well as the roofline. The galvanized finish is desirable above the roofline due to its higher corrosion resistance.

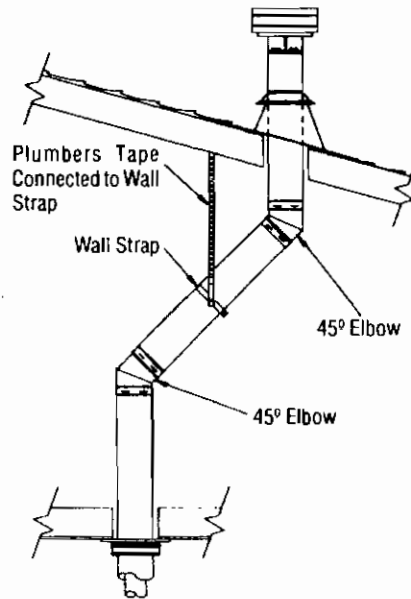

Figure 21

**E.** Slip the flashing Dura Vent Part No. 943 (0/12 to 6/12 Roof Pitch) or Dura Vent Part No. 943S (7/12 to 12/12 Roof Pitch) over the Pipe Section(s) protruding through the roof. Secure the base of the Flashing to the roof with roofing nails. Insure the roofing material overlaps the top edge of the Flashing as shown in Figure 23. Verify that you have at least the minimum clearance to combustibles at the roofline.

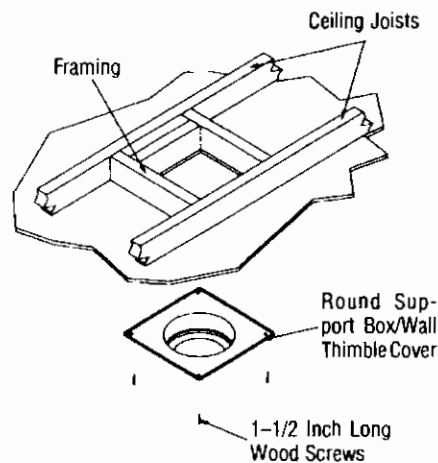

Figure 22

**F.** Continue to add Pipe Sections until the height of the Vent Cap meets the minimum building code requirements described in Vertical Venting on page 6. Note that for steep roof pitches, the vent height must be increased. In high wind conditions, nearby trees, adjoining rooflines, steep-pitched roofs, and other factors can result in poor draft, or a down draft condition. In these cases, increasing the vent height may solve this problem.

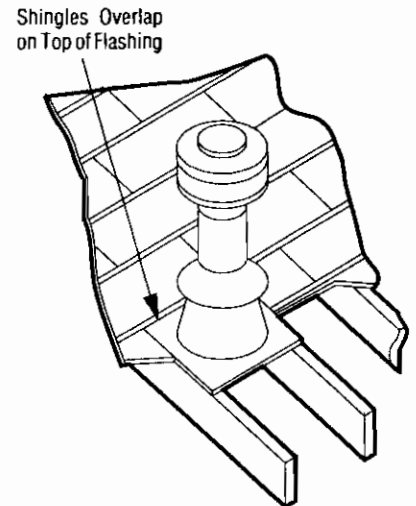

Figure 23

**G.** Twist lock the Vent Cap.

### Notes:

1. Maintain 1" minimum Clearance.
2. If an offset is necessary in the attic to avoid obstructions, it is important to support the vent pipe every 3 feet, to avoid excessive stress on the Elbows, and possible separation. Wall Straps Dura Vent Part No. 988, are available for this purpose (Figure 21).
3. Whenever possible, use 45 degree Elbows, instead of 90 degree Elbows. The 45 degree Elbows offer less restriction to the flow of flue gases and intake air.
4. For multi-story vertical installations, a Ceiling Firestop (Dura Vent Part No. 963) is required at the second floor, and any subsequent floors (Figure 24). The opening should be framed to 10-inch x 10-inch inside dimensions, in the same manner as shown in Figure 22.
5. Vent runs should never include more than three (3) 90 degree Elbows or six (6) 45 degree Elbows.

5. Any occupied areas above the first floor, including closets and storage spaces, which the vertical vents pass through, must be enclosed. The enclosure may be framed and sheetrocked with standard construction materials. On VERTICAL runs a 1" clearance to combustibles must be maintained. On HORIZONTAL runs a 3" top and 1" side and bottom clearance to combustibles must be maintained. Do not fill any of the required air spaces with insulation.

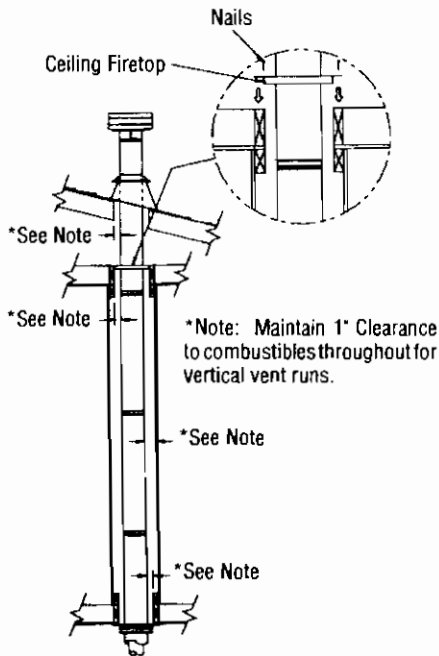

Figure 24

**Step 4. Connecting Gas Line** – Make gas line connections. All codes require a shut-off valve mounted in the supply line. Figure 25 illustrates two methods for connecting the gas supply.

The flex-line method is acceptable in the U.S., however, Canadian requirements vary depending on locality. Installation must be in compliance with local codes. The gas control valve is located on the right underside of the appliance. The control valve has a 3/8" flare fitting inlet port. Plan the connections accordingly.

Secure all joints tightly using appropriate tools and sealing compounds (ensure propane resistant compounds are used in propane applications). Turn on gas supply and test for gas leaks using a soapy water solution. **Never use an open flame to check for leaks.**

- A. Mix a 50% dish of soap, 50% water solution.
- B. Light the appliance (see safety and lighting instructions on page 18).
- C. Brush all joints and connections with the soapy water solution to check for leaks. If bubbles are formed, or gas odor is detected, turn the gas control knob to the "OFF" position. Either tighten or refasten the leaking connection and retest as described above.
- D. When the gas lines are tested and leak free, observe the individual tongues of flame on the burner. Make sure all ports are open and producing flame evenly across the burner. If any ports are blocked, or partially blocked, clean out the ports.

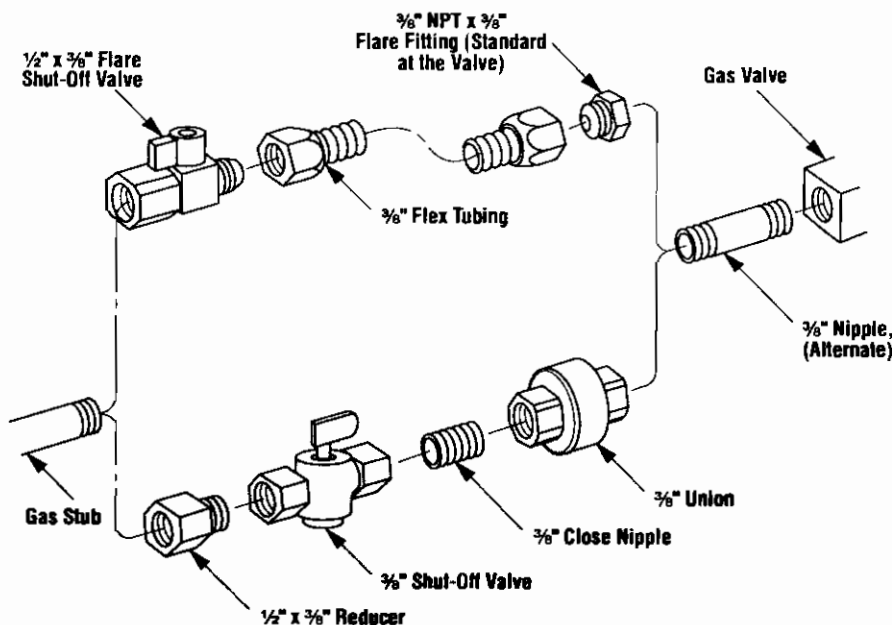

Figure 25

NOTE. DIAGRAMS & ILLUSTRATIONS NOT TO SCALE.

### High Elevation Derating

**WARNING: THE DERATING KIT IS TO BE INSTALLED BY AN AUTHORIZED JØTUL CERTIFIED SERVICE TECHNICIAN IN ACCORDANCE WITH THE MANUFACTURER'S INSTRUCTIONS AND ALL CODES AND REQUIREMENTS OF THE AUTHORITY HAVING JURISDICTION, FAILURE TO FOLLOW THESE INSTRUCTIONS COULD RESULT IN SERIOUS INJURY OR PROPERTY DAMAGE. THE QUALIFIED AGENCY PERFORMING THIS WORK ASSUMES RESPONSIBILITY FOR THIS DERATING.**

### In Canada

**THE DERATING SHALL BE CARRIED OUT IN ACCORDANCE WITH THE REQUIREMENTS OF THE PROVINCIAL AUTHORITIES HAVING JURISDICTION AND IN ACCORDANCE WITH THE REQUIREMENTS OF THE CAN1-B-149.1 AND .2 INSTALLATION CODE.**

This unit has been tested for installation at high altitudes in accordance with Canadian test standard CAN/CGA-2.17.

Higher altitudes affect the atmospheric pressure and heat value of gaseous fuels. When installing this unit at high altitudes, the lower oxygen content in the air and lower gas viscosity require installation of a different orifice to achieve efficient, clean combustion at the burners. Refer to the following charts an/or the rating plate on the appliance for proper orifice size.

To derate this unit, order and install the appropriate high altitude orifice kit per the following chart. Remove two (2) Phillips head screws securing the burner brackets to the base of the appliance firebox. Lift and remove the burner. Remove the orifice (Figure 26) and replace with the appropriate one from the kit. Refer to the following chart. Be sure to attach the conversion sticker provided with the kit to the rating plate on the appliance.

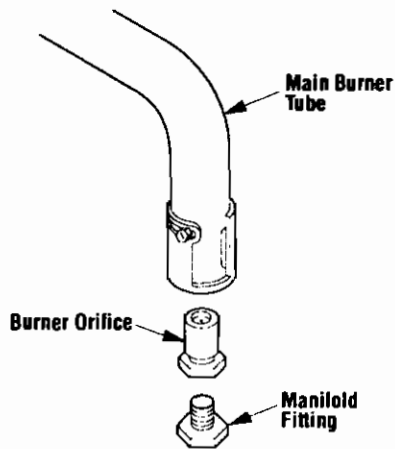

Figure 26

**Direct Vent Burner Orifice Requirements**

Gas Type	Orifice Size	High Alt Orf. Kit	Elevation
Natural	#31	—	0 - 2000' (0 - 610 m)
	#32	07-120020	2000 - 4500' (610 - 1370 m)
Propane	#50	—	0 - 2000' (0 - 610 m)
	#51	07-120021	2000 - 4500' (610 - 1370 m)

**Step 5. Installing Logs** – The logs are packaged in bubble wrap and placed within the firebox. Carefully position and center the fiber logs onto the burner with the scalloped and charred log in front and the smaller log in the back.

Carefully position the rear log and engage the (2) holes in the bottom of the log with the (2) pins of the burner assembly. Carefully position the front logs and engage the holes in the bottom of the logs with the pins in the burner assembly, (1) each. Position the #1 (D) twig to the left with char pattern toward the center, engage the pins on the front and rear logs. #2 (E) twig rests on top of #1 and engages with pins on the front and rear logs. Position #3 (F) log with flat spot or notch to rear and engage with the pins on front and rear logs.

Position #4 (G) with flat spot or notch to rear and engage with pins on front and rear logs. Position #5 (H) twig on the flat spots of #3 and #4 twigs. Note, if #4 twig is too far forward it will interfere with the door. If this occurs it may be necessary to move #5 log to the left so #4 twig can be moved back from the door.

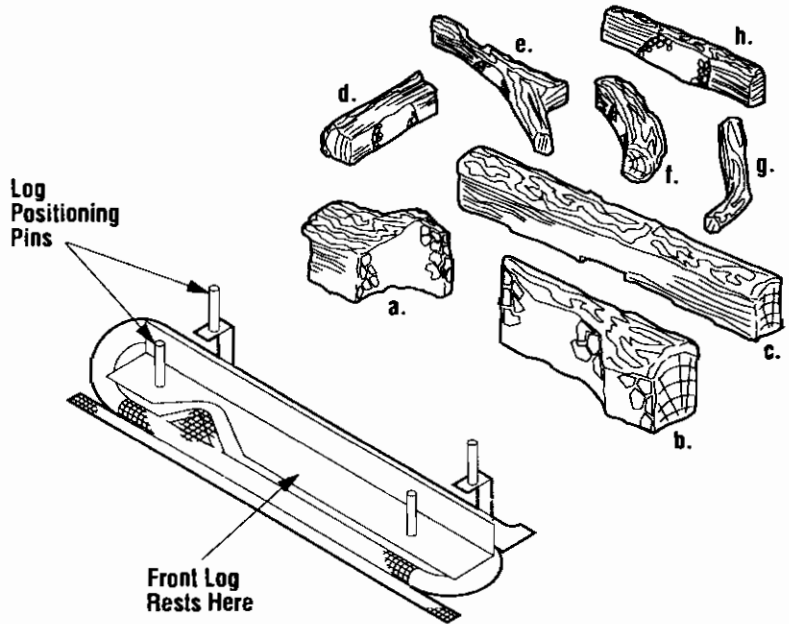

Figure 27

Carefully position the embers evenly across burner screen and arrange for desired effect. Note, if embers are positioned too tightly a long sooty flame may occur. This can be corrected by repositioning embers to allow more space between them.

**Appliance Operation**

**Step 6. Checking the System** – With gas line installed, run initial system checkout. Follow the pilot lighting instructions on page 18.

**Note:** Lighting instructions are also found on the pull out tray, below the front ash lip.

When first lighting the appliance, it will take a few minutes for the line to purge itself of air. Once purging is complete, the pilot and burner will light and operate as indicated in the instruction manual. Subsequent lightings of the appliance will not require such purging. Inspect the pilot flame (remove logs, if necessary, handling carefully).

The pilot flame should be steady, not lifting or floating. Flame should be blue in color with traces of orange at the outer edge.

The top 3/8" (10 mm) at the pilot generator (thermopile) and the top 1/8" min. (tip) of the quick drop out thermocouple should be engulfed in the pilot flame. The flame should project 1" (25 mm) beyond the hood at all three ports (Figure 28).

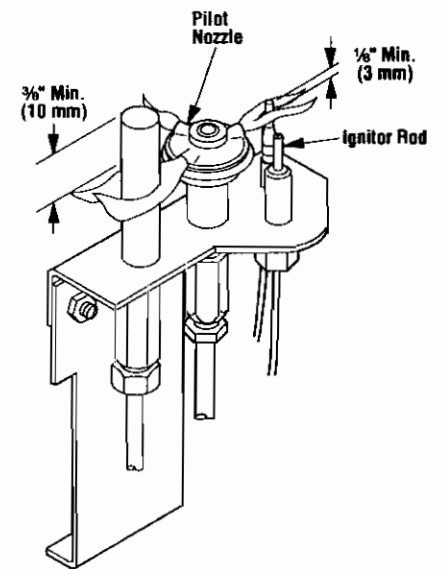
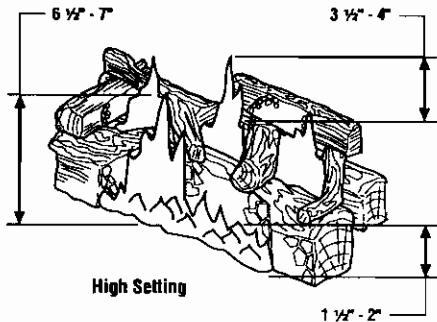

Figure 28

Replace logs if removed for pilot inspection.

To light the burner; turn "ON" the rocker switch or optional remote wall switch, and rotate the gas valve control knob counterclockwise to the "ON" position.

**Step 7. Burner Adjustments** – The JØTUL Firelight is equipped with a two stage (HI, LOW) gas control valve. This valve provides for easy flame height adjustment. To cycle the burner between the HI and LOW settings, rotate the HI/LOW knob, located in the center of the valve front face, clockwise and counter-clockwise respectively. Flame height will increase approximately 2" to 2 ½" when in the HI mode as referenced against the LOW mode. Flame height and appearance should be as shown in *Figure 29*. The following paragraphs detail flame appearance and adjustment. **Make all adjustments as described with HI/LOW knob set to HI.**



**Figure 29**

**Flame Appearance and Sooting**

Proper flame appearance is a matter of taste. Generally most people prefer the warm glow of a yellow to orange flame. Appliances operated with air shutter openings that are too large will exhibit flames that are blue and transparent. These weak, blue and transparent flames are termed anemic.

If the air shutter opening is too small sooting may develop. Sooting is indicated by black puffs developing at the tips of very long orange flames. Sooting results in black deposits forming on the logs, appliance inside surfaces and on exterior surfaces adjacent to the vent termination. Sooting is caused by incomplete combustion in the flames and a lack of combustion air entering the air shutter opening.

To achieve a warm yellow to orange flame with an orange body that does not soot, the shutter opening must be adjusted between these two extremes.

No smoke or soot should be present. Reposition the logs if the flames impinge on any of them.

**CAUTION: DO NOT ATTEMPT TO REDUCE OR ALTER THE FLAME BY POSITIONING THE GAS VALVE IN OTHER THAN THE FULL "ON" POSITION.**

If sooting conditions exist, the air shutter openings on the burner tube can be adjusted. Normally, the more offsets in the vent system, the greater the need for the air shutter to be opened further.

**WARNING: AIR SHUTTER ADJUSTMENT SHOULD ONLY BE PERFORMED BY A QUALIFIED PROFESSIONAL SERVICE TECHNICIAN.**

*Note: Ensure that the door is closed and sealed during adjustment burn cycles.*

**Adjustment**

**CAUTION: THE AIR SHUTTER AND NEARBY APPLIANCE SURFACES ARE HOT. EXERCISE CAUTION TO AVOID INJURY WHILE ADJUSTING FLAME APPEARANCE.**

There are two adjustments that can be made to create a desired flame appearance. A HI/LO knob, located on the gas valve, should be used to adjust the flame height. The air shutter, located just above the burner orifice, should be used to adjust flame color and soot level.

To adjust the burner flame, open or close the air shutter. Position the air shutter to the nominal setting (*Figure 30*). Close the door. Allow the burner to operate for at least 30 minutes. Observe the flame continuously. If it appears weak or sooty as previously described, allow the appliance to cool, then open the glass door and adjust the air shutter. Repeat the procedure until the flame appearance is as desired.

When satisfied that the appliance operates properly, proceed to finish the installation. Leave the control knob/lever in "ON" position, and turn the remote switch "OFF".

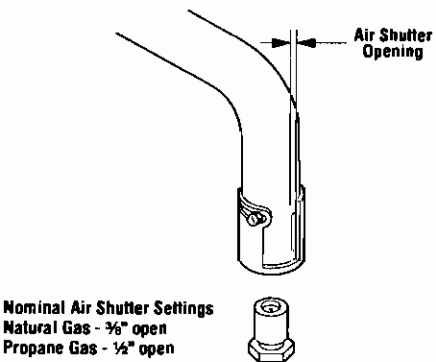

**Figure 30**

**JØTUL FIRELIGHT SERIES OPTIONS**

The following paragraphs detail the kit options available for use with the appliance covered in this manual. Kit part numbers are provided on page 16 along with descriptive illustrations.

**Forced Air Kit**

The Forced Air Kit (*Figure 31*) with its blower and variable speed switch provides a forced air circulation feature for your appliance. This kit mounts directly into the lower intake chamber with an electrical connection made at the wall receptacle. The appliance must have an independent 120Vac power line incorporated at the time of installation.

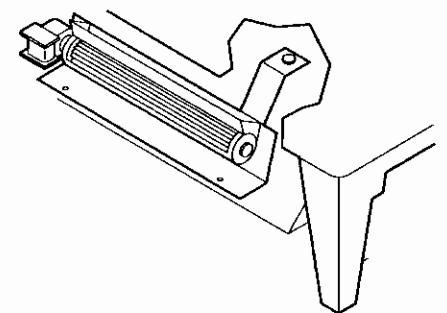

**Figure 31**

**Installing the Optional Forced Air Blower Kit Wiring.**

Your JØTUL Firelight appliance can be fitted with a forced air blower. The blower, decorative fan shield, and required hardware are provided in the Forced Air Blower Kit part number 07-120010.

To install the forced air blower, follow the instructions provided with the kit and make provisions for the following concerns:

Route a 3-wire, 120Vac power line to a standard wall outlet located near the lower left rear corner of the appliance. Make connections to the receptacle as shown in *Figure 32*.

If any of the original wire as supplied must be replaced, it must be replaced with Type AWM 105°C - 18 GA. wire or it's equivalent.

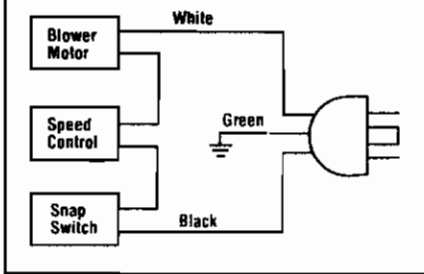

Figure 32

The appliance must be electrically grounded (Figure 32) in accordance with local codes or, in the absence of local codes, the National Electrical Code, ANSI/NFPA 70-1987. (In Canada, the current CSA C22 C22-1 Canadian Electrical Code).

The forced air blower kit may be mounted at initial appliance installation or at any time thereafter. Follow the instructions provided with the blower kit.

#### Remote Control Kit

The Optional Remote Control Kit Part Number 07-750002 adds the convenience of remote control for your appliance. The kit includes a wireless, hand held transmitter and a receiver. This special receiver permits either manual or remote control modes. Both receiver and transmitter operate on standard 9 volt batteries (not included). Refer to the Remote Control Kit installation instructions for specific details.

#### Wall Mounted Thermostat Kit

An optional wall mounted thermostat kit, part number 07-750003, can be installed along with the JØTUL Firelight. The wall mounted thermostat kit should be installed along with the appliance.

**Installing the Optional Remote Wall Switch or Wall Thermostat** – The standard JØTUL Firelight system comes from the factory wired as shown in Figure 33. Select a convenient location for the remote wall switch or wall thermostat and connect the wiring to the appliance.

**CAUTION: DO NOT CONNECT THE OPTIONAL REMOTE SWITCH TO A 120V POWER SUPPLY.**

**Note:** The standard rocker switch is mounted to the appliance valence and wired in the same way as the remote wall switch.

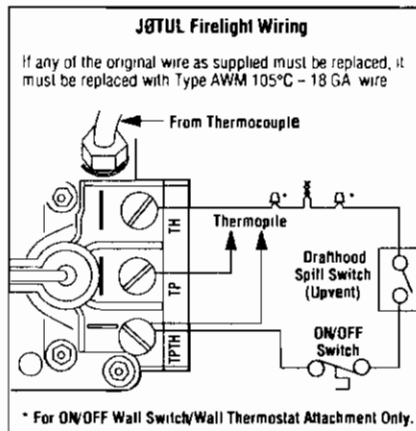

Figure 33

#### Gas Conversion Kits

**WARNING: THE CONVERSION KIT IS TO BE INSTALLED BY AN AUTHORIZED JØTUL SERVICE TECHNICIAN IN ACCORDANCE WITH THE MANUFACTURE'S INSTRUCTION AND ALL CODES AND REQUIREMENTS OF THE AUTHORITY HAVING JURISDICTION. FAILURE TO FOLLOW THESE INSTRUCTIONS COULD RESULT IN SERIOUS INJURY OR PROPERTY DAMAGE. THE QUALIFIED AGENCY PERFORMING THIS WORK ASSUMES RESPONSIBILITY FOR THIS CONVERSION.**

#### In Canada

**THE CONVERSION SHALL BE CARRIED OUT IN ACCORDANCE WITH THE REQUIREMENTS OF THE PROVINCIAL AUTHORITIES HAVING JURISDICTION AND IN ACCORDANCE WITH THE REQUIREMENTS OF THE CAN1-B149.1 AND .2 INSTALLATION CODE.**

Gas conversion kits are available to adapt your direct vent appliance from the use of one type of fuel to the use of another. These kits contain all the necessary components needed to complete the task including labeling that must be affixed to ensure safe operation. Kit part numbers are listed below and the following steps detail the conversion procedure.

#### Conversion Kits

P/N 07-120022 – Natural to Propane  
P/N 07-120023 – Propane to Natural

NOTE. DIAGRAMS & ILLUSTRATIONS NOT TO SCALE.

**Step 1.** Turn off the gas supply to the appliance. Remove the door handle locking screw. Open door.

**Step 2.** Carefully remove the top twigs. Then remove the three (3) main logs. Exercise care as not to break or scratch the logs.

**Step 3.** Disconnect the gas line to remove the gas valve spud plate assembly. Mark and remove the wires from the gas valve.

**Step 7.** Reassemble all removed components by reversing the procedures outlined in the preceding steps. Use pipe joint compound or Teflon tape on all fittings before installing (ensure propane resistant compounds are used in propane applications).

**Step 8.** Attach conversion kit label to the rating plate on the appliance; Label E for units converted to natural gas or Label H for units converted to propane (Figure 34).

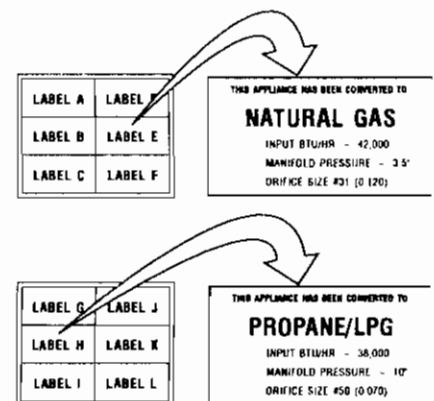

Figure 34

**Step 9.** Turn on gas supply and test for gas leaks as described in the gas line connection instructions, Step 4 on page 11.

**WARNING: CHILDREN AND ADULT SHOULD BE ALERTED TO THE HAZARD OF HIGH SURFACE TEMPERATURES. US CAUTION AROUND THE APPLIANCE TO AVOID BURNS OR CLOTHING IGNITION. YOUNG CHILDREN SHOULD BE CAREFULLY SUPERVISED WHEN THEY ARE IN THE SAME ROOM AS THE APPLIANCE.**

## OPERATION AND CARE OF YOUR APPLIANCE

1. Appliance operation is controlled through the rocker switch or optional wall thermostat. A separate switch provides independent control for the optional forced air blower.
2. When lit for the first time, this appliance will emit a slight odor for an hour or two. This is due to the "burn-in" of internal paints and lubricants used in the manufacturing process.
3. Upon each lighting of the appliance, condensation may occur and fog the inside of the glass on the door. This condition will disappear shortly as the appliance heats.
4. Keep lower controls clean by vacuuming or brushing at least twice a year.
5. Always turn off gas to the pilot before cleaning. Before re-lighting, refer to the lighting instruction in this manual. Instructions are also found on a pull-out panel located on the valence of the appliance.
6. Always keep the appliance area clear and free from combustible materials, gasoline and other flammable liquids.
7. Remember, this appliance has a continuous burning pilot flame. Exercise caution when using products with combustible vapors.

**WARNING: OBSERVE CAUTION NEAR THE DOOR. THE GLASS PANEL MAY SHATTER UNEXPECTEDLY IF STRUCK WITH AN OBJECT**

8. **CAUTION: DO NOT OPERATE THIS APPLIANCE WITH THE INNER GLASS DOOR OPEN OR IF THE GLASS IS CRACKED OR BROKEN.** Where broken glass exists, the complete door assembly must be replaced. See the Replacement Parts List on page 20 for correct parts.
9. Clean the glass only when necessary. Wipe surface with a clean, dampened, soft cloth. Follow with a dry, soft towel as desired. Take care not to scratch the glass surface.

**WARNING: DO NOT USE ABRASIVE CLEANERS. NEVER CLEAN THE GLASS WHEN IT IS HOT.**

## Maintenance

The appliance and venting system should be inspected before use and at least annually by a qualified service technician.

**IMPORTANT: TURN OFF GAS AND ANY ELECTRICAL POWER BEFORE SERVICING THE APPLIANCE.**

The main burner compartment should be inspected annually for proper operation. Open the door and perform general cleaning to remove any surface build-up on pilot and burner assembly. Wipe the pilot nozzle and igniter rod (Figure 28).

When returning to service, verify proper flame characteristics as described in Step 7, refer to Figure 29.

## Gasket Inspection

It is important that the door gasket be inspected at the beginning of the heating season by a qualified technician. Examine the sealing gasket for signs of deterioration. Also make sure the gasket has a positive seal, preventing combustion gases from escaping into the room. Replace the door gasket if necessary, refer to the Replacement Parts List on page 20.

With proper care and maintenance, your appliance will provide many years of enjoyment. If you should experience any problem, first refer to the troubleshooting guide in this manual. If problems persist, contact your local service center.

Retain this manual. File it with your other documents for future reference.

## REPLACEMENT PARTS

A complete parts list is found at the end of this manual. Use only parts manufactured and/or approved by JØTUL USA.

**WARNING: THE GLASS DOOR OF THIS APPLIANCE IS MANUFACTURED WITH CERAMIC GLASS 5 MM THICK. DO NOT ATTEMPT TO SUBSTITUTE THE GLASS MATERIALS USED ON THIS DOOR. DO NOT ATTEMPT TO REPLACE THE GLASS DOOR OR GLASS WITH ANYTHING OTHER THAN JØTUL MANUFACTURED AND SUPPLIED MATERIALS. FAILURE TO COMPLY WITH THESE REQUIREMENTS WILL VOID THE PRODUCT WARRANTY AND LIMIT MANUFACTURER LIABILITY.**

All parts should be ordered through your JØTUL dealer. Parts will be shipped at prevailing prices at time of order.

When ordering repair parts, always give the following information:

1. The model number of the appliance.
2. The serial number of the appliance.
3. The part number.
4. The description of the part.
5. The quantity required.
6. The installation date of the appliance.

## ACCESSORY PARTS AND COMPONENT LIST FOR JØTUL FIRELIGHT VENTED GAS FIREPLACE

The accessory parts and components on page 16 are to be used only with this appliance system. Separate installation instructions are packaged with most accessories.

If you encounter any problems or have any questions concerning the installation or application of this system, please contact your JØTUL Dealer. For the name of your nearest JØTUL Dealer contact:

**JØTUL USA, INC.  
400 RIVERSIDE STREET  
PORTLAND, MAINE 04104**

## Natural Gas Models

Color	Part Number	Weight
Black Paint	970251	275 lbs.
Blue Black Enamel	970252	275 lbs.
Green Enamel	970290	275 lbs.
Indigo Blue Enamel	970265	275 lbs.

## Propane Gas Models

Color	Part Number	Weight
Black Paint	971251	275 lbs.
Blue Black Enamel	971252	275 lbs.
Green Enamel	971290	275 lbs.
Indigo Blue Enamel	971265	275 lbs.

**ACCESSORIES AND COMPONENTS**

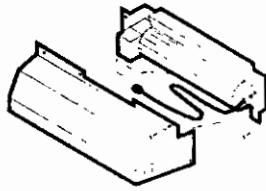

**Forced Air  
Blower Kit** P/N 07-120010

---

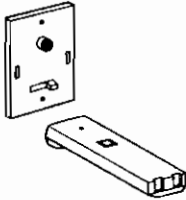

**Remote Control** P/N 07-750002

---



**Conversion Kit**  
Natural P/N 07-120022  
Propane P/N 07-120023

---

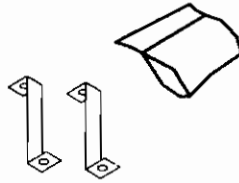

**Floor Bracket Kit** P/N 04-950081

---

**Direct Vent Units**

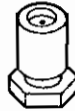

**High Altitude  
Orifice Kit** P/N 07-120020  
Natural P/N 07-120021  
Propane P/N 07-120021

---



**Wall Mounted  
Thermostat** P/N 07-750003

---



# TROUBLESHOOTING THE MILLIVOLT GAS CONTROL SYSTEM

## JØTUL Firelight Model

**Note:** Before troubleshooting the gas control system, be sure external gas shut off valve (located at gas supply inlet) is in the "ON" position.

SYMPTOM	POSSIBLE CAUSES	CORRECTIVE ACTION
1. Spark ignitor will not light pilot after repeated triggering of red button.	A. Defective ignitor (no spark at electrode).	Check for spark at electrode and pilot; if no spark and electrode wire is properly connected, replace ignitor.
	B. Defective or misaligned electrode at pilot (spark at electrode).	Using a match, light pilot. If pilot lights, turn off pilot and trigger the red button again. If pilot lights, an improper gas mixture caused the bad lighting and a longer purge period is recommended. If pilot will not light – check gap at electrode and pilot – should be 1/8" (3 mm) to have a strong spark. If gap measures 1/8", replace pilot (Figure 30).
	C. Gas supply pressure errant.	Check inlet gas pressure. It should be within the limits as marked on the rating plate.
	D. Pilot orifice plugged.	Clean or replace pilot orifice.
	E. Rear log too close to Ignitor.	Move rear log further back.
2. Pilot will not stay lit after carefully following the lighting instructions.	A. Defective pilot generator (thermopile) or remote wall switch.	Check pilot flame, it must impinge on pilot generator (Figure 30). Clean and/or adjust pilot for maximum flame impingement on generator.
		Be sure wire connections from generator at gas valve terminals are tight and generator is fully inserted into pilot bracket.
		One of the ON/OFF switch wires may be grounded. Remove wall switch wires from valve terminals. If pilot now stays lit, trace ON/OFF switch wiring for ground. May be grounded to appliance or gas supply.
		Check pilot generator with millivolt meter. Take reading at generator terminals of gas valve. Should read 325 millivolts minimum while holding valve knob depressed in pilot position and the ON/OFF switch toggled "OFF." Replace faulty pilot generator if reading is below specified minimum.
	B. Defective automatic valve operator.	Turn valve knob to "ON," place ON/OFF switch to "ON." Millivolt meter should read greater than 100 mv. If the reading is okay and the burner does not come on, replace the gas valve.
3. Pilot burning, no gas to burner, valve knob "ON," ON/OFF switch "ON."	A. Ignition switch or wires defective.	Check ON/OFF switch and wires for proper connections. Jumper wire across terminals at ON/OFF switch, if burner comes on, replace defective wall switch. If okay, jumper wires across ON/OFF switch wires at valve, if burner comes on, wires are faulty or connections are bad.
	B. Pilot generator may not be generating sufficient millivoltage.	Re-check Symptom #2.
	C. Plugged burner orifice.	Check burner orifice for stoppage and remove.
4. Frequent pilot outage problem.	A. Pilot flame may be too low or blowing (high) causing the pilot safety to drop out.	Clean and/or adjust pilot flame for maximum flame impingement on pilot generator (Figure 30).

## LIGHTING INSTRUCTIONS

### FOR YOUR SAFETY READ BEFORE LIGHTING

**WARNING: IF YOU DO NOT FOLLOW THESE INSTRUCTIONS EXACTLY, A FIRE OR EXPLOSION MAY RESULT CAUSING PROPERTY DAMAGE, PERSONAL INJURY OR LOSS OF LIFE.**

- A.** This appliance has a pilot which must be lighted by hand. When lighting the pilot, follow these instructions exactly.
- B. BEFORE LIGHTING** smell all around the appliance area for gas. Be sure to smell next to the floor because some gas is heavier than air and will settle on the floor.

#### WHAT TO DO IF YOU SMELL GAS

- Extinguish any open flame.
- Open windows.
- Do not light any appliance.
- Do not touch any electrical switches.
- Do not use any phone in your building.

- Immediately call your gas supplier from a neighbor's phone.
  - If your gas supplier cannot be reached, call the fire department.
- C.** Use only your hand to push in or turn the gas control knob. Never use tools. If the knob will not push in or turn by hand, do not try to repair it, call a qualified service technician. Force or attempted repair may result in a fire or an explosion.
- D.** Do not use this appliance if any part has been under water. Immediately call a qualified service technician to inspect the appliance and to replace any part of the control system and any gas control which has been under water.

## LIGHTING INSTRUCTIONS

1. **STOP!** Read the safety information above on this page.
2. Access the lower controls.
3. Turn ON/OFF switch to "OFF", or set the thermostat to lowest setting (if used).
4. Verify main line shut-off valve is open.
5. Push in gas control knob slightly and turn clockwise to "OFF."

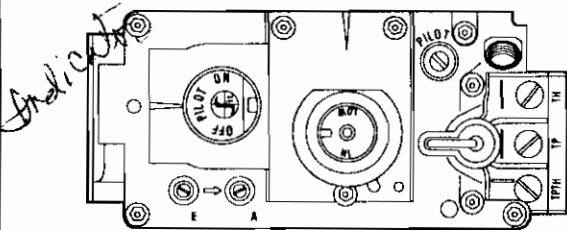

**Note:** Knob cannot be turned from "PILOT" to "OFF" unless the knob is pushed in slightly. Do not force.

6. Wait five (5) minutes to clear out any gas. If you then smell gas, STOP! Follow "B" in the safety information above on this page. If you do not smell gas, go to the next step.

7. Push in gas control knob slightly and turn counterclockwise to "PILOT."
8. Push in control knob all the way and hold in. Immediately light the pilot by triggering the spark ignitor (pushing red button) until pilot lights. Continue to hold the control knob in for about 1 1/2 minutes after the pilot is lit. Release knob and it will pop back up. Pilot should remain lit. If it goes out, repeat steps 5 through 8.

- If knob does not pop up when released, stop and immediately call your service technician or gas supplier.
- If pilot will not stay lit after several tries, turn the control knob to "OFF" and call your service technician or gas supplier.

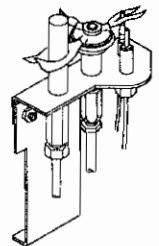

9. Turn gas control knob counterclockwise to "ON."
10. Turn ON/OFF switch to "ON", or set thermostat to desired setting (if used).

*white indicator*

## TO TURN OFF GAS TO APPLIANCE

1. Turn ON/OFF switch "OFF." The pilot will remain lit for normal service.
2. For complete shutdown, turn ON/OFF switch to "OFF."
3. Access the lower controls.
4. Depress gas control knob slightly and turn clockwise to "OFF." Do not force.

## INSTRUCTIONS D'ALLUMAGE

### POUR VOTRE SÉCURITÉ, LISEZ-LES AVANT L'ALLUMAGE

**AVERTISSEMENT : SI VOUS NE SUIVEZ PAS CES INSTRUCTIONS À LA LETTRE, IL POURRAIT S'ENSUIVRE UN INCENDIE OU UNE EXPLOSION CAUSANT DES DOMMAGES MATÉRIELS, DES BLESSURES CORPORELLES OU MÊME DES PERTES DE VIE.**

**A.** Cet appareil est muni d'une veilleuse qui doit être allumée à la main. Lorsque vous allumez la veilleuse, suivez exactement ces instructions.

**B. AVANT DE VOUS EN SERVIR**, sentez tout autour de l'appareil où il pourrait y avoir une odeur de gaz. Reniflez près du plancher car, le gaz étant plus lourd que l'air, il se dépose sur le plancher.

#### VOICI CE QUE VOUS DEVEZ FAIRE SI VOUS DÉCELEZ UNE ODEUR DE GAZ:

- Éteignez toutes les flammes nues.
- Ouvrez les fenêtres.
- N'allumez aucun appareil.
- Ne touchez à aucun commutateur électrique.
- Ne vous servez d'aucun téléphone dans votre édifice.

- Appelez immédiatement votre compagnie de gaz en utilisant le téléphone d'un voisin.
- S'il vous est impossible de contacter votre compagnie de gaz, appelez le service des incendies.

**C.** Servez-vous uniquement de votre main pour tourner ou pour enfoncer le bouton de réglage du gaz. N'employez jamais un outil. Si le bouton refuse de tourner ou de bouger, ne tentez pas de le réparer. Appelez un technicien compétent et expérimenté. Si vous essayez de le forcer ou de le réparer, vous pourriez causer un incendie ou une explosion.

**D.** Ne vous servez pas de cet appareil si l'un de ses éléments a été immergé dans l'eau. Appelez immédiatement un technicien compétent pour faire inspecter l'appareil et remplacer toute pièce du système de réglage ou commande du gaz qui a été sous l'eau.

## INSTRUCTIONS D'ALLUMAGE

1. **ARRÊTEZ !** Lisez les consignes de sécurité ci-dessus.

2. Ouvrez le contrôle du bas.

3. Tournez le bouton "On/Off" dans la position "Off" ou bien mettez le thermostat dans la position la plus basse. (ci c'est utiliser)

4. Assurez-vous que la soupape d'arrêt de la canalisation principale est ouverte.

5. Enfoncez légèrement le bouton de réglage du gaz et tournez-le dans le sens des aiguilles d'une montre jusqu'à la position d'arrêt "OFF".

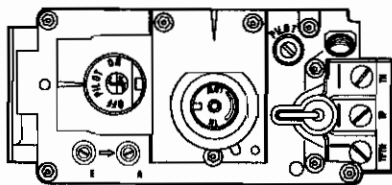

*Remarque: Il est impossible de tourner le bouton de "PILOT" à "OFF" à moins qu'il ne soit légèrement enfoncé. Ne le forcez pas.*

6. Attendez cinq (5) minutes pour en laisser sortir le gaz, le cas échéant. Si vous décelez une odeur de gaz, **ARRÊTEZ !** Retournez au point "B" des consignes de sécurité ci-dessus. Si vous ne remarquez aucune odeur de gaz, passez à l'étape suivante.

7. Enfoncez légèrement le bouton de réglage du gaz et tournez-le en sens inverse des aiguilles d'une montre jusqu'à la

position de veilleuse "PILOT".

8. Enfoncez le bouton de réglage jusqu'au fond et gardez-le enfoncé. Allumez immédiatement la veilleuse en déclenchant l'allume-gaz à étincelle (en poussant le bouton rouge) jusqu'à ce que la veilleuse s'enflamme. Continuez de tenir le bouton de réglage enfoncé pendant environ 90 secondes après l'allumage de la veilleuse. Relâchez le bouton et il sortira subitement. La veilleuse devrait rester allumée. Si elle s'éteint, répétez les étapes 5 à 8 inclusivement.

- Si le bouton ne sort pas automatiquement après avoir été relâché, arrêtez immédiatement et téléphonez à votre technicien de service ou à votre fournisseur de gaz.

- Si la veilleuse refuse de rester allumée après plusieurs tentatives, tournez le bouton de réglage jusqu'à sa position d'arrêt "OFF" et téléphonez à votre technicien de service ou à votre fournisseur de gaz.

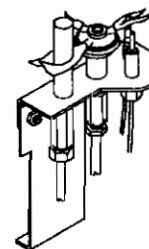

9. Tournez le bouton de réglage du gaz en sens inverse des aiguilles d'une montre jusqu'à sa position de marche "ON".

10. Tournez le bouton dans la position "On" ou bien mettez le thermostat dans la position désirée. (ce c'est utiliser)

## POUR FERMER LE GAZ QUI ALIMENTE L'APPAREIL

1. Tournez le bouton "On/Off" dans la position "Off". La veilleuse restera allumée jusqu'au retour du service normal.

2. Pour éteindre complètement, tournez le bouton "On/Off" dans la position "Off".

3. Ouvrez le contrôle du bas.

4. Enfoncez légèrement le bouton de réglage du gaz et tournez-le dans le sens des aiguilles d'une montre jusqu'à sa position d'arrêt "OFF". Ne le forcez pas.

## JØTUL FIRELIGHT REPLACEMENT PARTS LIST

Item	Description	Natural Gas Part Number	Propane Gas Part Number
1.	Firebox Assembly	07-120001	07-120002
2.	Log Support Weldment	07-125611	07-125611
3.	Door Frame	07-124521	07-124521
4.	Glass Assembly	07-1202633	07-1202633
5.	Latch	07-1201896	07-1201896
6.	Burner Weldment	07-124971	07-124971
7.	Spudplate Assembly	-	-
8.	Valve Gas	07-3902159	07-3902160
9.	Pilot Assembly	07-3902161	07-3902162
10.	Fitting Assembly	07-12099679	07-12099679
11.	Orifice	07-12901932	07-12901933
12.	Elbow Tube	07-12094519	07-12094519
13.	Logs	-	-
13a.	FLDV – Left Front Log	07-120011	07-120011
13b.	FLDV – Right Front Log	07-120012	07-120012
13c.	FLDV – Rear Log	07-120013	07-120013
13d.	FLDV – Upper Left Log	07-120014	07-120014
13e.	FLDV – Upper/Inner Left Log	07-120015	07-120015
13f.	FLDV – Upper/Inner Right Log	07-120016	07-120016
13g.	FLDV – Upper Right Log	07-120017	07-120017
13h.	FLDV – Upper 3rd. Tier, Right Log	07-120018	07-120018
14.	Firebox Mount Rear	07-124021	07-124021
15.	Dura-Vent Collar	07-12902513	07-12902513
16.	Gasket Outer-Vent	07-12902515	07-12902515
17.	Gasket Inner-Vent	07-12902514	07-12902514
18.	Extension On-Off Knob	07-3902582	07-3902582
19.	Extension Hi-Low Knob	07-3902581	07-3902581
20.	Bag of Embers	07-754506	07-754506
21.	Fan Bracket Door Assembly	07-125661	07-125661
22.	Fan Bracket	07-124550	07-124550
	Blower Assembly (Not Shown)	07-120010	07-120010
	Remote (Not Shown)	07-750002	07-750002
	Wall Mounted Thermostat (Not Shown)	07-750003	07-750003

# REPLACEMENT PARTS – PAGE ONE

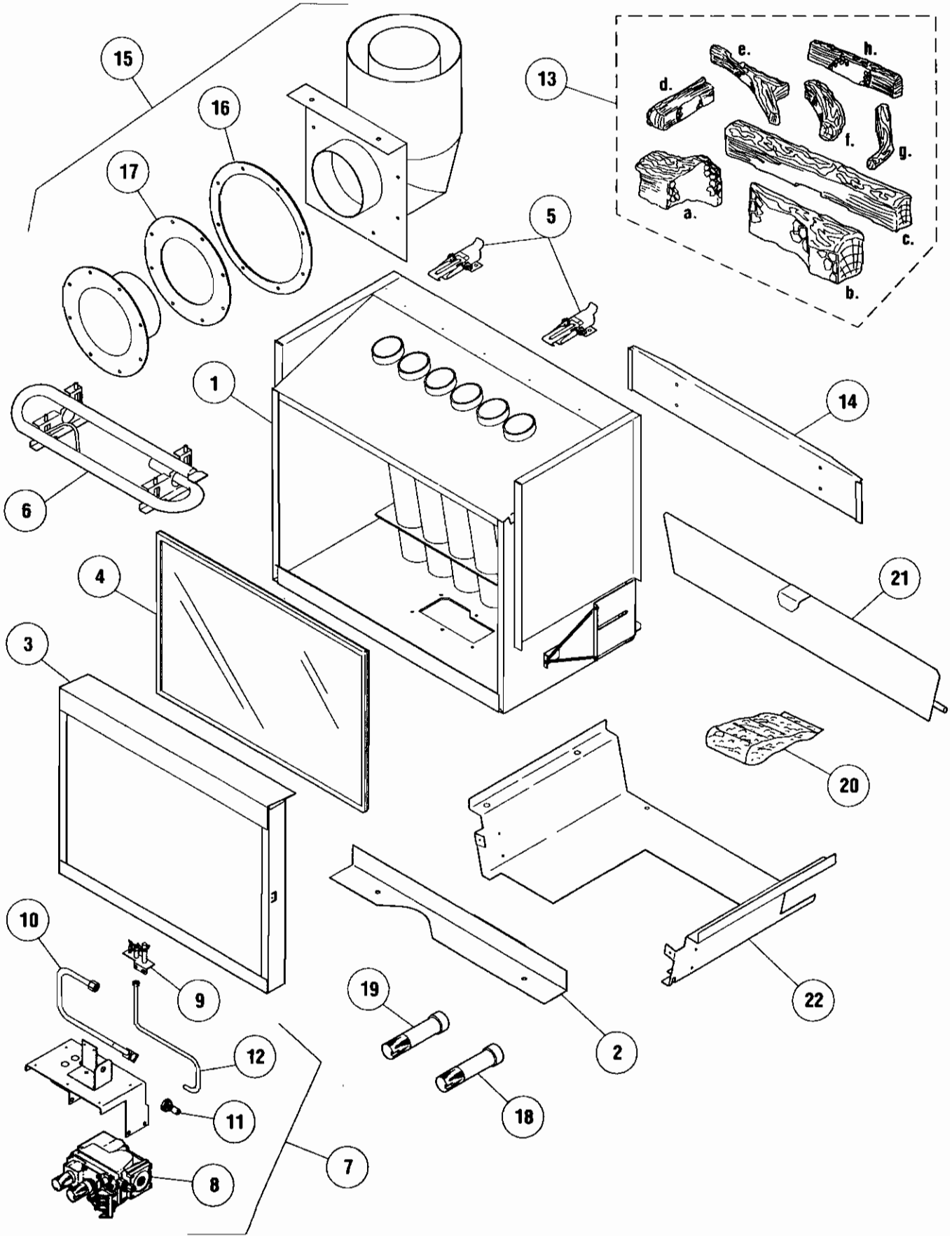

NOTE. DIAGRAMS & ILLUSTRATIONS NOT TO SCALE.

**JØTUL FIRELIGHT  
REPLACEMENT PARTS LIST (CONTINUED)**

Item	Enameled Parts				Description
	Matte	Blue/Black	Green	Indigo Blue	
23.	10379592	10379527	10379532	10379536	Base Plate
24.	10379992	10379927	10379932	10379936	Front Plate
25.	10381592	10381527	10381532	10381536	Side Plate (Right)
26.	10381492	10381427	10381432	10381436	Side Plate (Left)
27.	10379792	10379727	10379732	10379736	Top Plate
28.	10379792	10379827	10379832	10379836	Top Grille
29.	10382092	10341527	10332032	10332036	Door (Right)
30.	10332192	10341627	10332132	10332936	Door (Left)
31.	10333292	10341327	10333232	10333236	Leg
32.	10379692	10379627	10379632	10379636	Ashlip
33.	15328692	15328627	15328632	15328636	Stove Tool
34.	10334292	10341427	10334232	10334236	Cover, Bottom Surround
	35029692	35029727	35029932	35035936	Warming Shelves (Not Shown)

Item	Non-Enameled Parts	
	Part Number	Description
35.	103713	Assembly Bracket
36.	125960	Hinge Pins
37.	128011	Door Latch
38.	128359	Latch Bolt
39.	126164	Spring, Latch Bolt
40.	9935	Nut, 10 mm
	350169	Screen (Not Shown)
41.	200028	Gasket
42.	9976	8 mm Washer
43.	99115	8 x 12 Hex Bolt
44.	99131	8 x 25 Hex Bolt
45.	117835	6 x 20 Set Screw

**REPLACEMENT PARTS ARE AVAILABLE THROUGH YOUR AUTHORIZED JØTUL DEALER**

REPLACEMENT PARTS - PAGE TWO

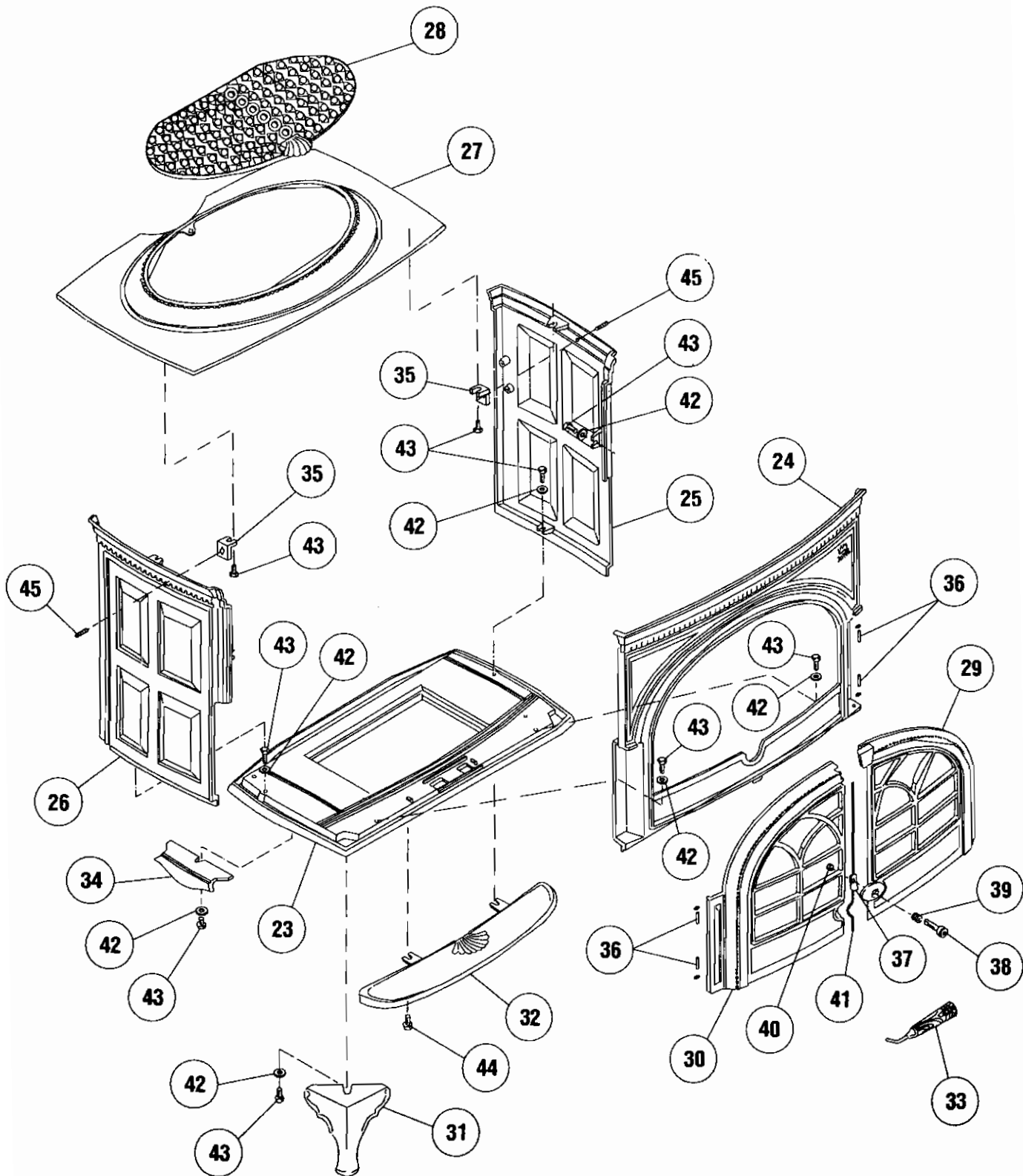

NOTE: DIAGRAMS & ILLUSTRATIONS NOT TO SCALE.

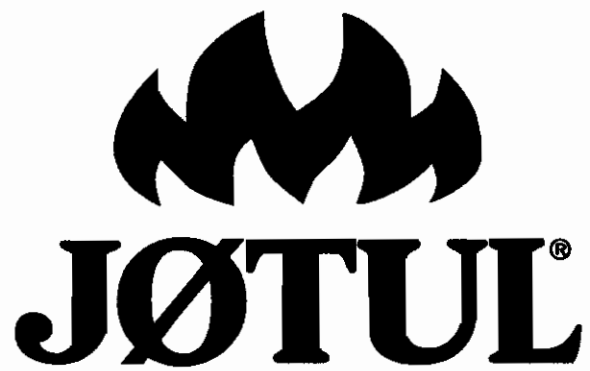

---

JØTUL USA reserves the right to make changes at any time, without notice, in design, materials, specifications, prices and also to discontinue colors, styles and products. Consult your local distributor for fireplace code information

Printed in U.S.A. © 1998 by JØTUL USA  
P/N 903766 REV. B 7/98

**JØTUL USA, Inc.**  
400 Riverside Street  
Portland, Maine 04104