

SECTION 3 - HEAT STORAGE SYSTEMS

3.2 Site-Built EPDM Storage Tank

Generally speaking, the larger the storage tanks connected to the Jetstream, the longer the homeowner can go between firings. Since each installation is dependent on the house in question we suggest the homeowner consult his Jetstream dealer on storage requirements.

For new homes, built-in concrete cisterns are recommended. For other homes "EPDM" rubber lined tanks constructed from plywood and 2" x 6" lumber are recommended.

In all cases, KERR recommends using a pressurized loop with a heat exchanger in a large, unpressurized storage tank, as shown below:

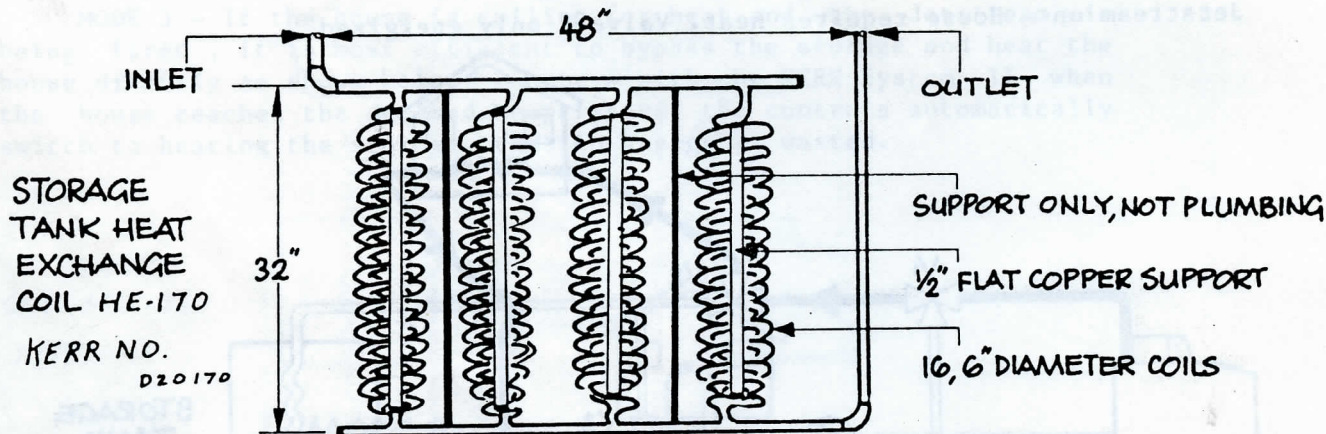

Coil rating should be 170,000 BTU/h at 40 F temperature differential and 10 gallons per minute(U.S.). A typical coil with 1 1/4" connections, as illustrated above would consist of 4 coils of 1/2" finned copper 16 turns in 32 inches. NOTE - This type of coil is recommended to ensure good heat transfer when taking heat from storage.

Alternatively, a simpler heat exchanger can be made as shown, using 80' of 1" hard copper with return bend elbows soldered to the lenthns of pipe. A shaped coil may be also made of 100' of soft copper. This coil may not function as effectively as the one shown above.

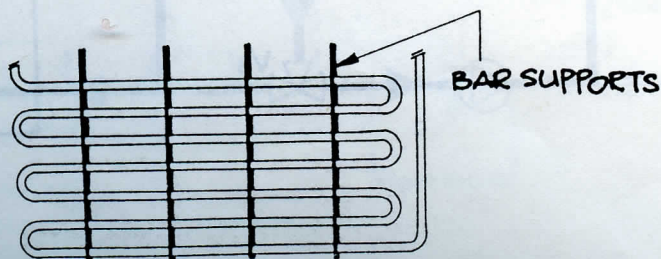

SECTION 3 - HEAT STORAGE SYSTEMS

Material List for Site Built EPDM Storage Tank:

Tank Dimensions (outside)	5x8	8x8
Tank Size (U.S. Gals.)	640	1163
(Imp. Gals.)	533	969
EPDM LINER SIZE - Tank	152"x188"	188"x188"
- Top	5x8	8x8
EPDM Total Size	20' wide	20' wide
	188" length	24' leng
LUMBER - 2" x 6" x 8'	25	46
- 1/2" plywood CDX or exterior grade	5	6
INSULATION		
- 2" Pearlboard or Thermax Insulation 4' x 8'	7	8
Fibreglass Insulation 6" x sq.ft.	150	192
OTHER - Staples		
3" Common Galvanized Nails	3lbs.	4lbs.
Silicone Sealant - 2 tubes		
3/8" x 4" carriage bolts washers and nuts	96	96
Maximum Firing Interval		
Radiation 60 degree F. rise	6 hrs.	11.6 hrs.
Warm Air 90 degree F. rise	9.2 hrs.	16.74 hrs.

Note: 50,000 BTU Heat Loss - Worst Days in Winter.

Consult Jetstream Technical Bulleting No. 1 for in depth study.

Tanks sized to make best use of lumber and 42" water height.

SECTION 3 - HEAT STORAGE SYSTEMS

3.2.1 Tank Frame Construction

STEP 1.

Construct six(6) frames of 2" x 6" as shown. Take dimensions from table below for desired tank size.

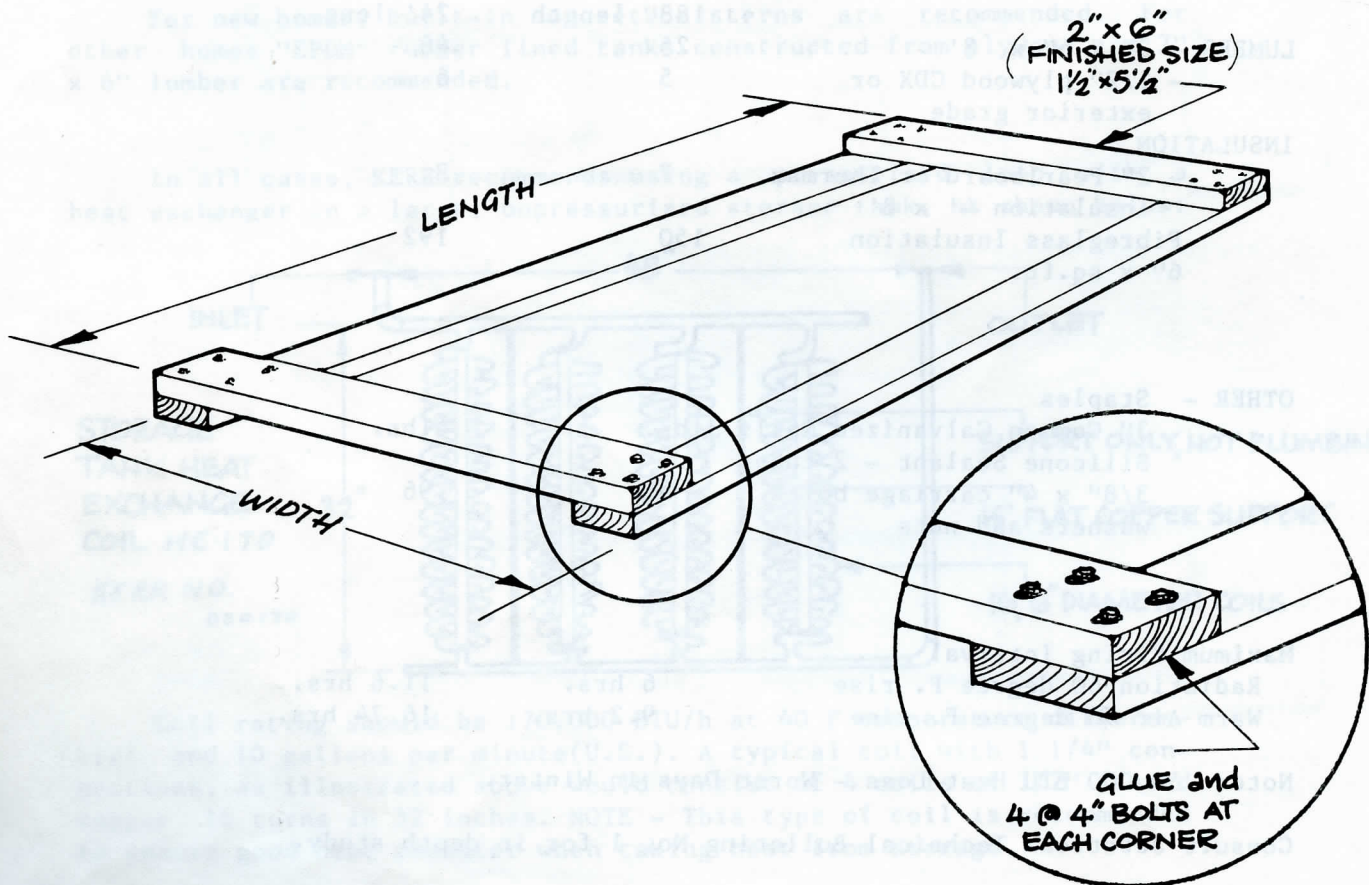

Tank Size (Gallons)	Width	Length
640 U.S. (533 Imp.)	5'	8'
1163 U.S. (969 Imp.)	8'	8'

SECTION 3 - HEAT STORAGE SYSTEMS

STEP 2.

Place 1/2" plywood in bottom frame as shown:

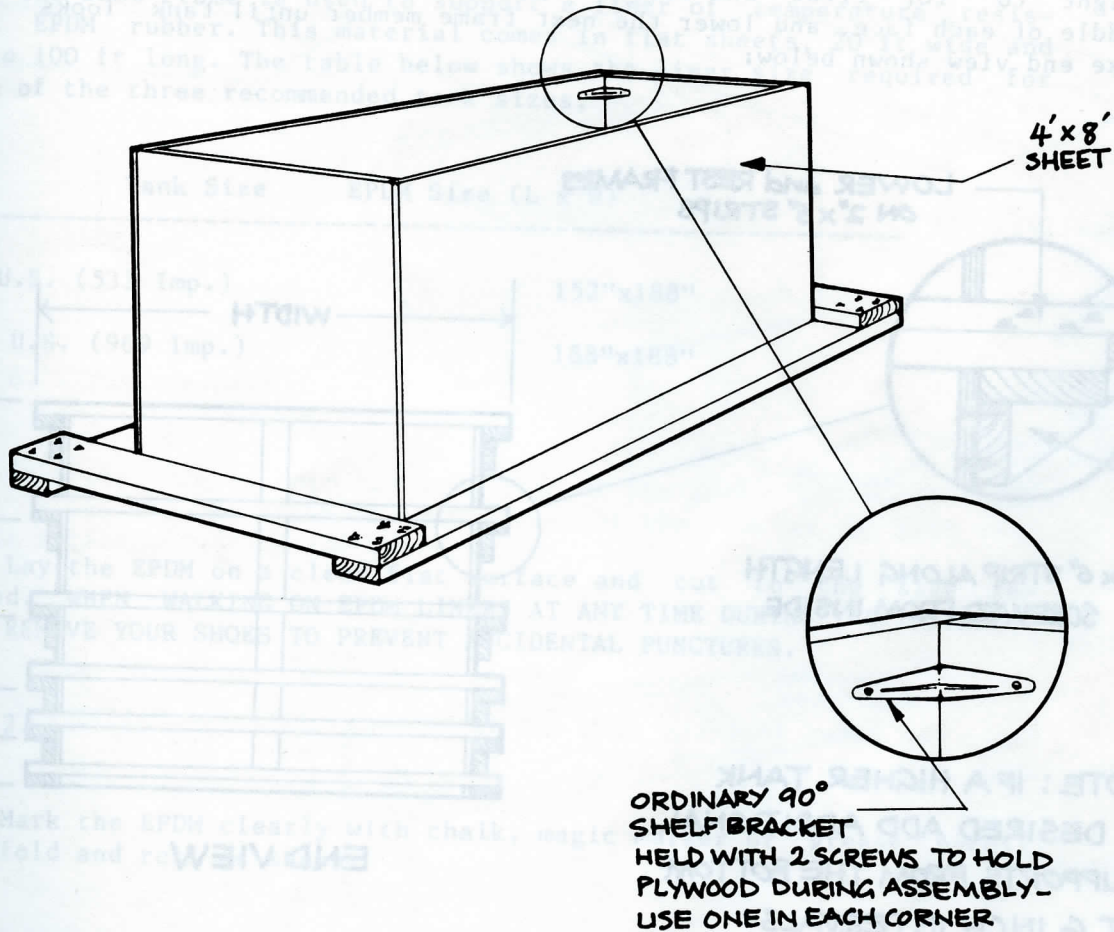

STEP 3.

Place one 2" layer of aluminized pearlboard (Thermax) insulation in from the top of the tank to line the tank bottom.

NOTE: A provision should be made to protect tank in wet basement conditions. (polyethylene)

STEP 4.

Place other frames one by one. First place blocks of the proper height (6" for first and second layers, 9" for third, etc.) in the middle of each face, and lower the next frame member until tank looks like end view shown below:

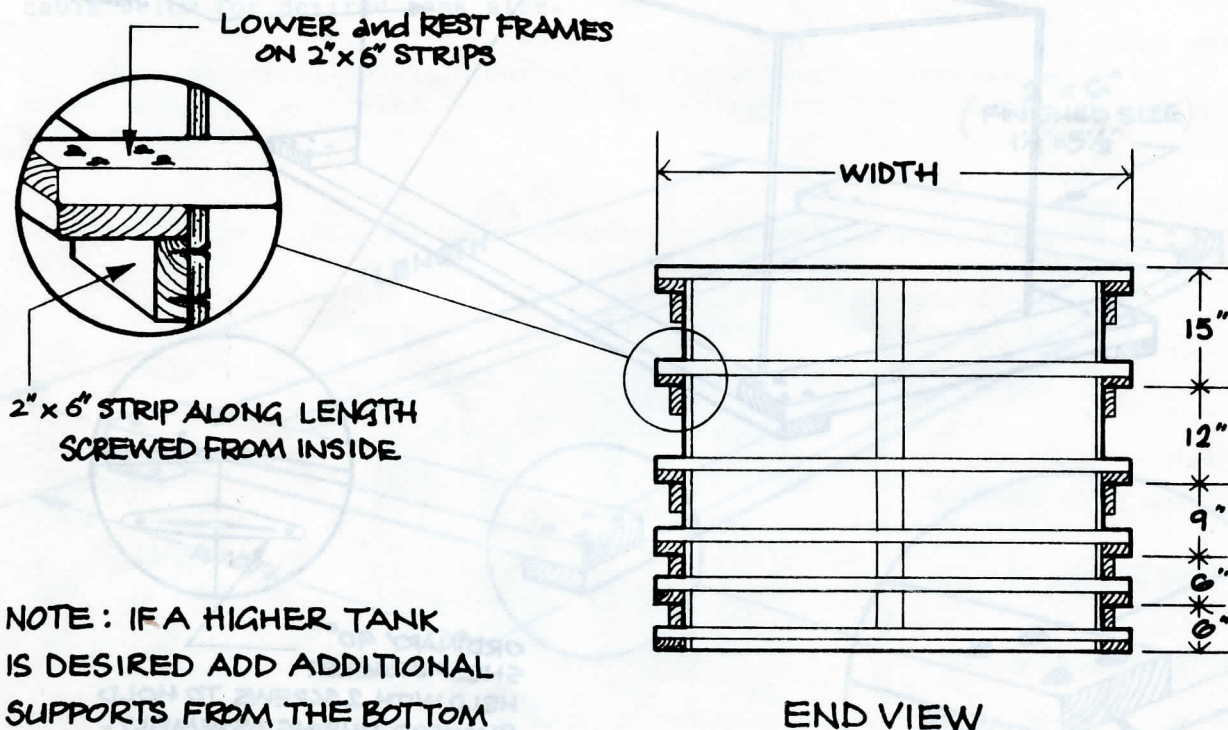

NOTE: IF A HIGHER TANK IS DESIRED ADD ADDITIONAL SUPPORTS FROM THE BOTTOM AT 6 INCH INTERVALS

STEP 5.

Place 2" PURLBOARD (Thermax) on inside walls of tank (all 4 sides). Remove shelf bracket from inside of plywood.

STEP 6.

Insulate outside of tank with 6" Fibreglass insulation held by pegboard, panelling (or 6 mil polyethylene with SLITS in it so it does NOT form a vapor barrier).

3.2.2 EPDM Liner

The wood frame is used to support a liner of temperature resistant EPDM rubber. This material comes in flat sheets, 20 ft wide and up to 100 ft long. The table below shows the liner size required for each of the three recommended tank sizes;

Tank Size	EPDM Size (L x W)
640 U.S. (533 Imp.)	152"x188"
1163 U.S. (969 Imp.)	188"x188"

STEP 1.

Lay the EPDM on a clean flat surface and cut to the size required. WHEN WALKING ON EPDM LINERS AT ANY TIME DURING THE INSTALLATION REMOVE YOUR SHOES TO PREVENT ACCIDENTAL PUNCTURES.

STEP 2.

Mark the EPDM clearly with chalk, magic marker or grease pencil then fold and roll as shown:

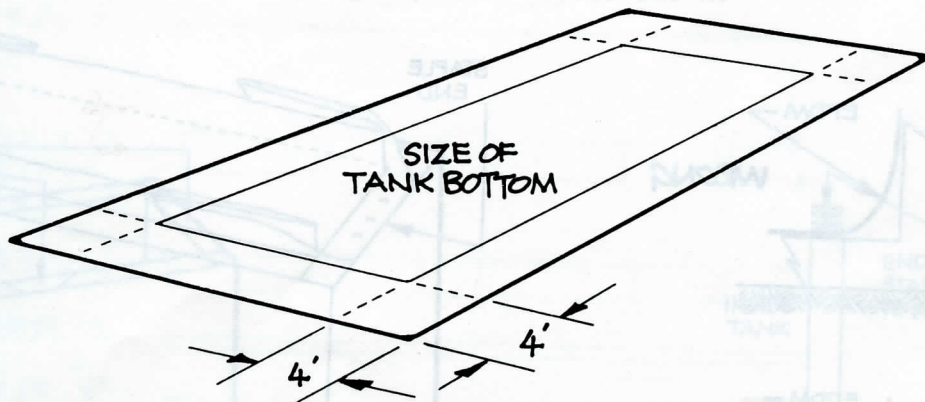

First fold sides

Next fold ends in

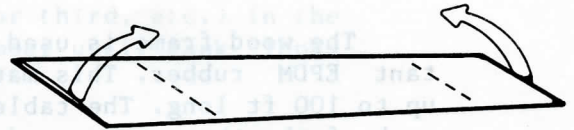
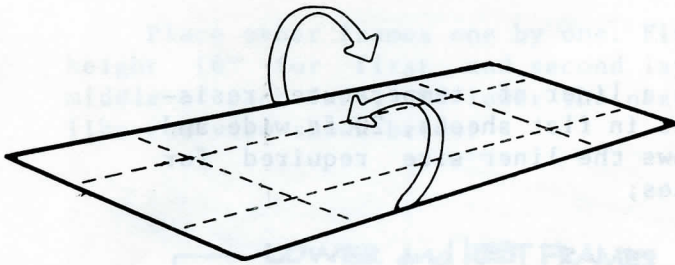

Finally, roll up



STEP 3.

Place the liner into the tank and roll it out onto the bottom of the tank.

STEP 4.

Unfold the ends and staple to the top 6" support frame...be careful that the liner tucks into the bottom edge as shown. Do not staple within one (1) foot of corners at this time.

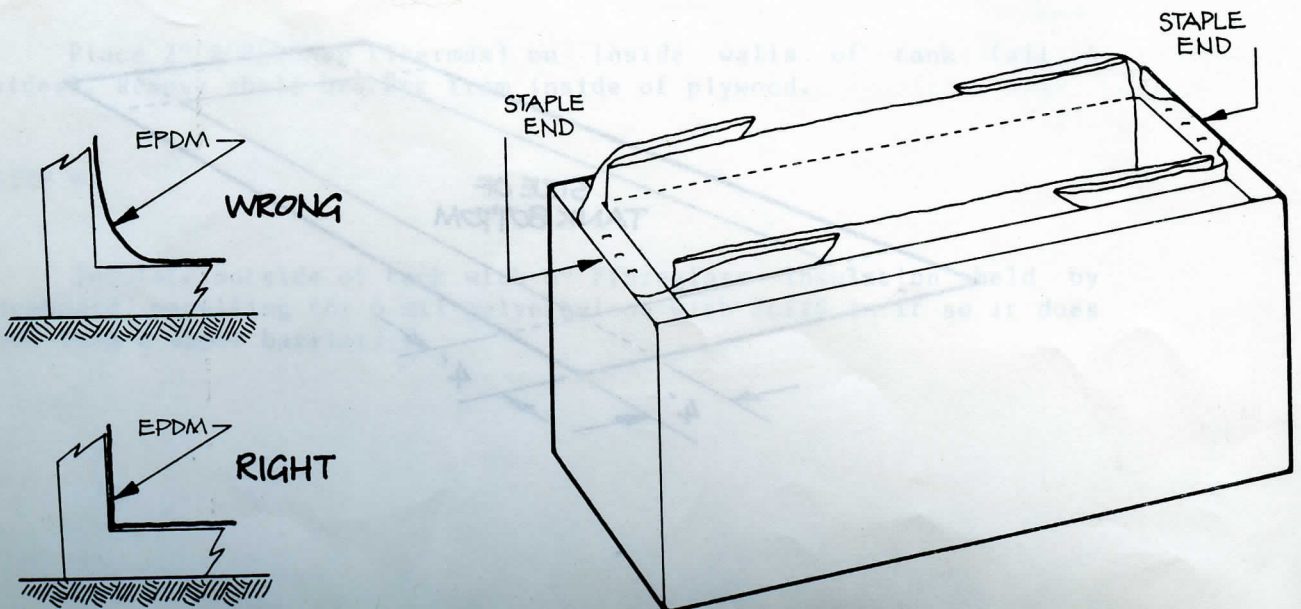

STEP 5.

Repeat step 4 for the remaining sides. Make sure positioning is correct by using marks made on EPDM earlier.

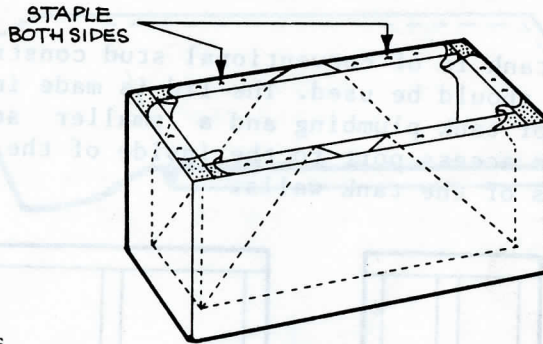

STEP 6. - Tank Corners

Fold the corners onto the long side of the tank. Cut, with scissors, a six(6) inch cut at each corner of the tank so the EPDM will not be stretched around the corner.

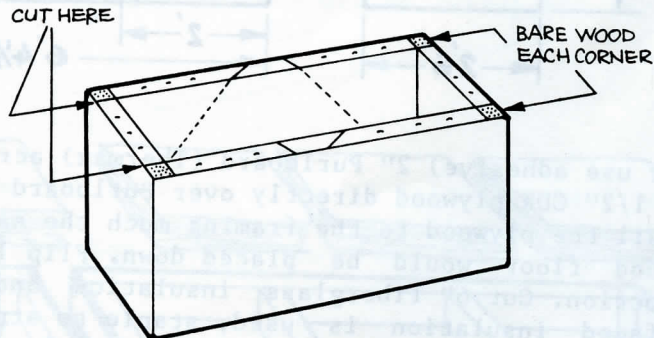

STEP 7.

Now staple small pieces of EPDM in each bare corner and then add EPDM as shown to build the whole edge up to 3 layers thick.

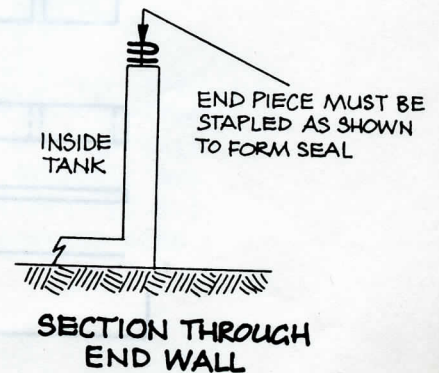
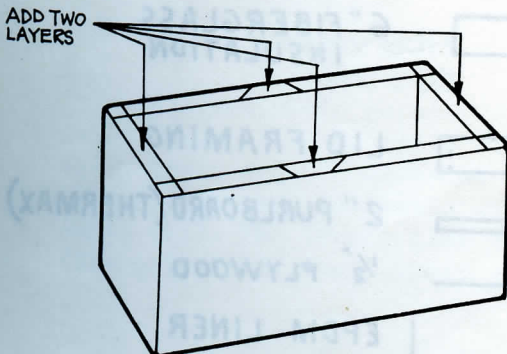

3.2.4 Constructing the Top

The lid of the tank is of conventional stud construction, 2" x6" studs, 24" on center should be used. The lid is made in two sections a large main section for tank plumbing and a smaller section approximately 2' wide for an access port to the inside of the tank. Frame lid to outside dimensions of the tank walls.

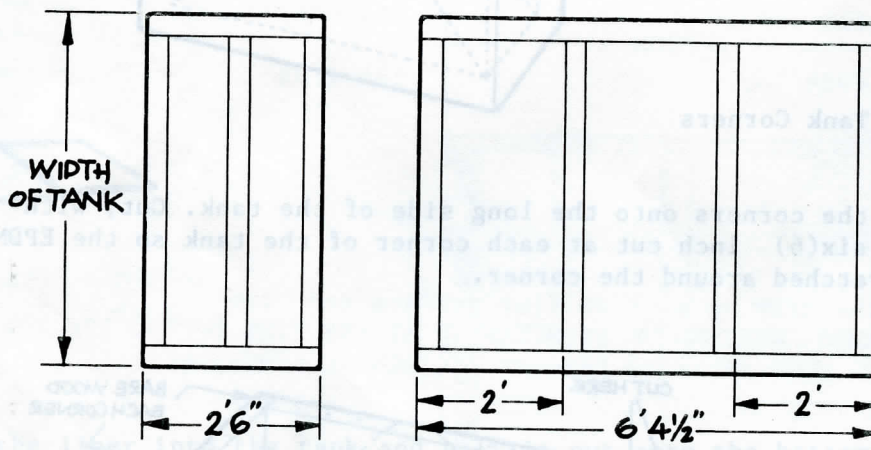

Nail (or use adhesive) 2" Purlboard (Thermax) across the entire lid. Lay out 1/2" CDX plywood directly over Purlboard (Thermax). Using 16d nails, nail the plywood to the framing much the same way a conventional plywood floor would be placed down. Flip lid over exposing frame construction. Cut 6" fiberglass insulation and place between studs. If faced insulation is used, staple to studs. If batts are used, twine is recommended to hold fiberglass in place. The top may also be filled with KERR Cellulose Insulation.

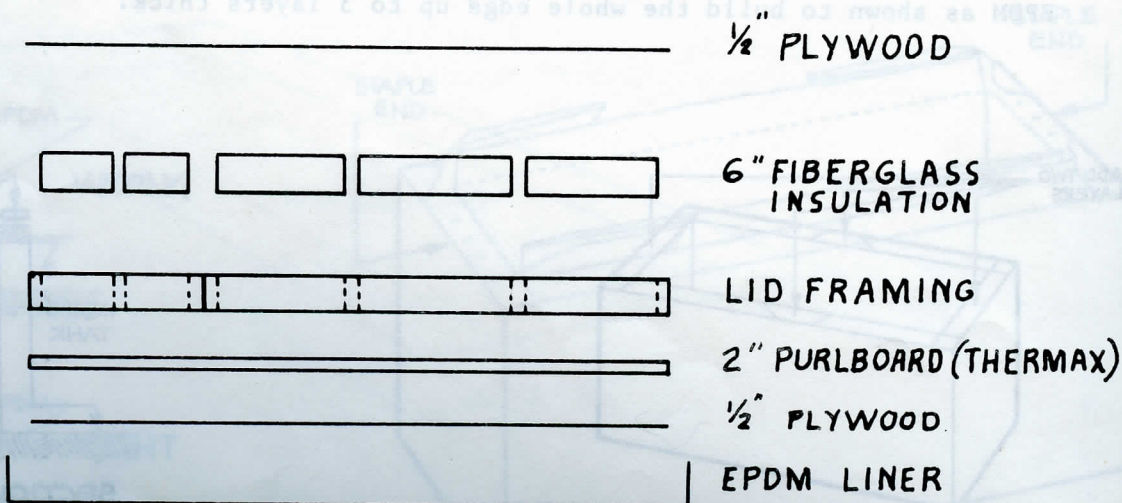

Lay EPDM of same size as outside dimensions of tank on large piece of top and staple.

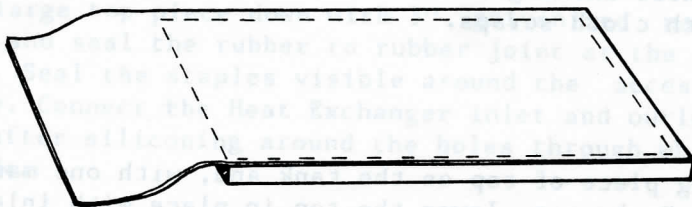

Drill 2 holes 48" on center in center of plywood on large lid, 1-1/2" in diameter.

Cut two (2) slits over the holes in the plywood in the EPDM layer for inlet and outlet of heat exchanger. These should fit snugly against heat exchanger tubing.

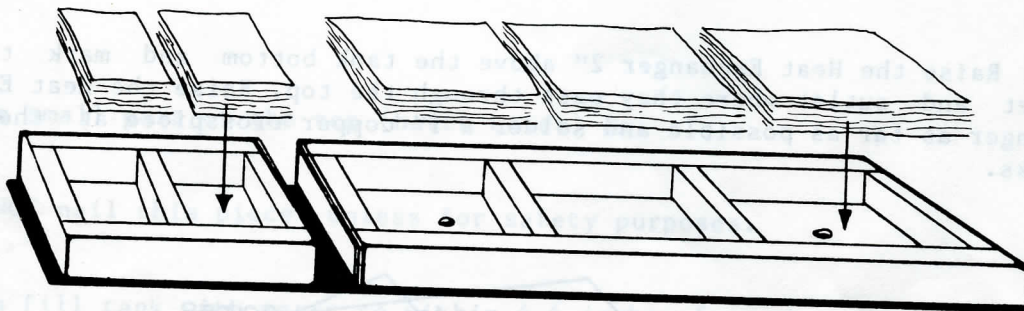

3.2.5 Installing Heat Exchanger and Completing Top

Lift the Heat Exchanger into the tank, being careful to cover all sharp edges with cloth scraps.

Place long piece of top on the tank and, with one man inside to guide the Heat Exchanger, lower the top in place with inlet and outlet through the precut holes.

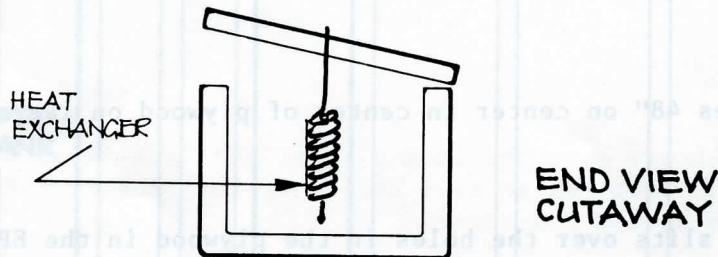

Note: Mark inlet and outlet on top of tank (see heat exchanger illustration).

Raise the Heat Exchanger 2" above the tank bottom and mark the inlet and outlet where they pass through the top. Raise the Heat Exchanger as far as possible and solder a 1" copper crosspiece at these marks.

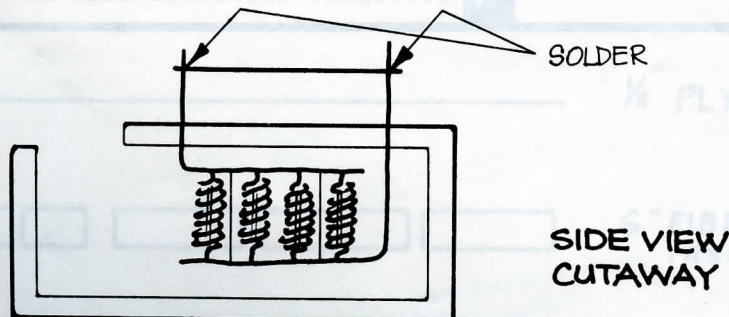

Now lower the Heat Exchanger until the crosspiece supports it. The Heat Exchanger should NOT be resting on the tank bottom.

Completion

Toe nail the large top piece down with 3" galvanized nails. Go inside the tank and seal the rubber to rubber joint at the top-side edge with silicone. Seal the staples visible around the access hatch edges with silicone. Connect the Heat Exchanger inlet and outlet (see piping diagrams), after siliconing around the holes through which they pass from the inside.

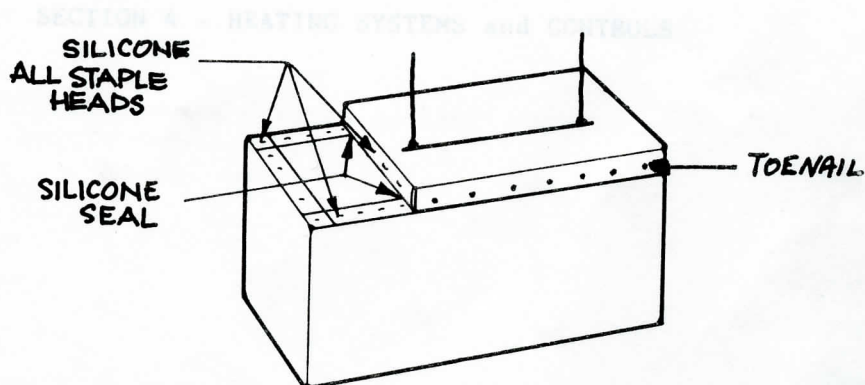

Place the small part of the top (hatch cover) on.

Do NOT nail this piece, unless for safety purposes.

Then fill tank with water to within 4-6 inches from the top and test the system checking for leaks.

3.3 Pressurized Steel Tanks

In areas where permitted by building code a storage system may be built up using multiple steel tanks. These tanks are available from KERR. These are 30" diameter diameter x 60" high and 30" x 72" high tanks. They are available with or without openings for a domestic hot water coil. The larger tank holds approximately 220 gallons (U.S.) (184 gal. IMP.) For further information have your dealer contact KERR.