



**HEAT TECHNOLOGY MANUFACTURER**



**EN**

**ATTACK DPX**  
Instructions for use



# CONTENTS

|   |    |
|---|----|
| CONTENTS .....  | 3  |
| ATTACK DPX – THE WOOD GASIFYING BOILER.....                                     | 5  |
| 1 INTRODUCTION.....   | 7  |
| 1.1 GENERAL DESCRIPTION.....  | 7  |
| 1.2 MARKING OF THE BOILERS ATTACK DPX.....                                      | 7  |
| 1.3 TECHNICAL PARAMETERS.....   | 8  |
| 1.4 DIMENSIONS OF THE BOILERS ATTACK DPX.....                                   | 9  |
| 1.5 DIMENSIONS OF THE BOILER ATTACK DPX 80, 100.....                            | 10 |
| 1.6 CONTROL PANEL.....  | 11 |
| 1.6.1 ATTACK DPX STANDARD.....  | 11 |
| 1.6.2 ATTACK DPX LAMBDA.....  | 12 |
| 1.7 PURPOSE OF USE.....   | 13 |
| 1.8 TECHNICAL DESCRIPTION.....  | 13 |
| 2 TECHNICAL DESCRIPTION OF THE ATTACK DPX STANDARD.....                         | 14 |
| 2.1 OPERATING PRESCRIPTIONS.....  | 14 |
| 3 TECHNICAL DESCRIPTION OF THE ATTACK DPX PROFI.....                            | 16 |
| 3.1 ADVANTAGES OF THE REGULATOR.....  | 16 |
| 3.2 BASIC DESCRIPTION OF THE REGULATOR.....                                     | 17 |
| 3.3 CONNECTION OF THE REGULATOR BY HYDRAULIC SCHEMES.....                       | 18 |
| 3.3.1 WOOD GASIFYING BOILER + HEATING CIRCUIT.....                              | 18 |
| 3.3.2 WOOD GASIFYING BOILER + HEATING CIRCUIT + WARMING OF D.H.W.....           | 19 |
| 3.3.3 WOOD GASIFYING BOILER + HEATING CIRCUIT + WARMING OF ACCUMULATION TANK 20 |    |
| 3.3.4 WOOD GASIFYING BOILER + HEATING CIRCUIT + WARMING OF ACCUMULATION         |    |
| TANKS CONNECTED IN SERIE.....   | 21 |
| 3.3.5 WOOD GASIFYING BOILER + HEATING CIRCUIT + WARMING OF THE COMBINED         |    |
| ACCUMULATION TANK.....  | 22 |
| 3.4 REGULATOR CONTROL AND OPERATING MODES.....                                  | 23 |
| 3.5 SETTING THE USER PARAMETERS.....  | 24 |
| 3.6 SETTING THE SERVICE PARAMETERS.....   | 25 |
| 3.7 DESCRIPTION OF PARAMETERS.....  | 26 |
| 3.8 TESTING THE REGULATOR OUTPUTS.....  | 28 |
| 3.9 RESET OF THE REGULATOR'S PRODUCTION SETTINGS.....                           | 29 |
| 3.10 EXIT FROM SERVICE MENU.....  | 29 |
| 3.11 ERROR MESSAGES.....  | 29 |
| 3.12 DISASSEMBLY OF THE REGULATOR.....  | 29 |
| 3.13 TECHNICAL SPECIFICATION OF THE REGULATOR.....                              | 30 |
| 4 TECHNICAL DESCRIPTION OF THE ATTACK DPX LAMBDA.....                           | 30 |
| 4.1 REGULATION OF BURNING.....  | 30 |
| 4.2 IGNITING AND REFILLING THE FUEL.....  | 30 |
| 4.3 IGNITING OR REFILLING THE FUEL.....   | 31 |
| 4.4 REFILLING THE FUEL DURING THE BOILER OPERATION.....                         | 31 |
| 4.5 FUNCTION AND DISPLAYING THE TEXT BY IGNITING OR REFILLING THE FUEL.....     | 31 |
| 4.6 DISPLAY OF THE OPERATING MODE BY THE BOILER STARTED.....                    | 32 |
| 4.7 EXCESSIVE FLUE GAS TEMPERATURE.....   | 32 |
| 4.8 BOILER OVERHEATING.....   | 32 |

|      |  |    |
|------|--|----|
| 4.9  | DISPLAY OF THE OPERATING MODE WHEN THE BOILER IS OUT OF ORDER.....                   | 32 |
| 4.10 | FUNCTIONS OF THE AUTOMATIC PROTECTION .....  | 32 |
| 4.11 | INFORMATION ABOUT THE CURRENT OPERATION .....  | 33 |
| 4.12 | INFORMATION DISPLAYED:.....  | 33 |
| 4.13 | SETTING FOR COMMISSION OF THE ATTACK DPX LAMBDA .....                                | 34 |
| 4.14 | CANCELLATION OF THE PRODUCER'S FUNCTION.....   | 36 |
| 4.15 | SAFETY TEST .....  | 38 |
| 4.16 | MAINTENANCE OF THE HEATING SYSTEM AND THE BOILER .....                               | 39 |
| 4.17 | BOILER CLEANING.....   | 40 |
| 4.18 | PRESCRIBED FUEL .....  | 41 |
| 4.19 | ASSEMBLY AND INSTALLATION OF THE BOILER .....  | 41 |
| 4.20 | BOILER PROTECTION AGAINST CORROSION .....  | 44 |
| 4.21 | BINDING NORMS FOR PROJECTING AND INSTALLATION OF THE BOILERS .....                   | 45 |
| 4.22 | INSTALLATION AND REPLACEMENT OF THE FIREPROOF PARTS .....                            | 46 |
| 4.23 | INSTALLATION AND REPLACEMENT OF THE FIREPROOF PARTS DPX80.....                       | 47 |
| 4.24 | BOILER CONNECTION.....   | 47 |
| 4.25 | OPERATION WITH ACCUMULATION TANKS.....   | 48 |
| 4.26 | BOILER PROTECTION AGAINST OVERHEATING.....   | 48 |
| 4.27 | TRANSPORT, HANDLING AND STORING .....  | 49 |
| 4.28 | INSTRUCTIONS FOR PRODUCT DISPOSAL AFTER TERMINATION OF ITS SERVICE LIFE.....         | 49 |
| 4.29 | DISPOSAL OF THE PACKAGING .....  | 49 |
| 4.30 | ACCESSORIES .....  | 49 |
| 4.31 | POSSIBLE ERRORS AND SOLUTIONS.....   | 50 |
| 4.32 | FAULTS AND ERRORS WITH THE SYSTEM ATTACK DPX LAMBDA .....                            | 51 |
| 4.33 | CHARACTERISTICS OF THE WATER TEMPERATURE SENSOR (THE PROFI VERSION) .....            | 55 |
| 4.34 | ELECTRICAL SCHEMES OF CONNECTION OF THE BOILERS ATTACK DPX STANDARD,<br>LAMBDA ..... | 56 |
| 4.35 | ATTACK DPX PROFI .....   | 57 |
| 4.36 | ATTACK DPX LAMBDA.....   | 58 |
| 5    | RECOMMENDED SCHEMES OF CONNECTION.....   | 61 |
| 5.1  | CONNECTION OF THE BOILER WITH 1 HEATING CIRCUIT WITH DHW.....                        | 61 |
| 5.2  | CONNECTION OF THE BOILER WITH 1 HEATING CIRCUIT WITHOUT DHW.....                     | 62 |
| 5.3  | CONNECTION OF THE BOILER WITH 2 HEATING CIRCUITS WITHOUT DHW.....                    | 63 |
| 5.4  | CONNECTION OF THE BOILER WITH 2 HEATING CIRCUITS WITH DHW .....                      | 64 |
|      | EC DECLARATION OF CONFORMITY .....   | 65 |



## ATTACK DPX – THE WOOD GASIFYING BOILER

- Installation, heat-up test and user training must be performed by the technician trained by producer. The technician must fill the protocol about the installation of the boiler.
- By gasification of wood it comes to creation of tar and condensates (acids) in the fuel tank. Due to this there must be a mixing device installed behind the boiler to keep the minimum temperature of return water at 65 °C. The temperature of water in the boiler during its operation must be within the range of 80 – 90 °C.
- The boiler must not be permanently operated within the output lower than 50 %.
- If the circuit pump is being used, its operation must be controlled by a separate thermostat to ensure the prescribed minimum temperature of the return water.
- Ecological boiler operation is related to its nominal output.
- It is recommended to install the boiler together with the accumulation tank and mixing device. This ensures the fuel saving of 20 – 30 % and longer lifetime of the boiler and chimney.
- If it is not possible to connect the boiler to the accumulation tank, it should be connected with at least one equalization tank with the volume of approximately 25 l / 1 kW of the boiler's output.
- By the operation with lower output (summer operation and D.H.W. preparation) it is necessary to heat the boiler up every day.
- Only the dry fuel of 12 – 20 % moisture can be used (by the higher moisture of fuel is the boiler output decreased and its consumption increased).
- The DPX boiler liner is equipped with the tubular exchanger, except of the 15 DPX boiler. Tubes in the exchanger of the 15 DPX are cleaned by an appropriate kit delivered together with the boiler.
- Due to the economical operation and correct functionality it necessary to choose an appropriate boiler output. The nominal output of the boiler has to be adequate to the temperature loss of the heated object.
- **The boiler must be used only for the purpose that it is intended for and only in the way given in this manual.**



**CAUTION** – After disconnecting the boiler from electricity mains there is still fuel burning. Do not open the boiler door until the temperature decreases below 40 °C.

**The warranty for the boiler is not valid:**

- if it is not operated with the prescribed fuel – i.e. wood with the moisture lower than 20 %
- if no mixing device Regumat ATTACK-OVENTROP is installed in the system to ensure the return water temperature of at least 65 °C during the boiler operation
- if no functional thermostatic valve is installed on the after cooling circuit (WATTS STS20) of the boiler, connected to the cold water inlet.

This device is not supposed to be used by persons (including children) with physical, sensual or mental disability or insufficient experience due to which they are not able to use the device in a safe way without being supervised or instructed about the boiler operation by the person responsible for their safety. Do not to allow the children to play with the device.

**If the power supply cable is damaged, it must be replaced with a special cable available by producer or by a service technician!**

**Be careful by work with device! The Lambda sensor works by high temperatures (300 °C) and there is a danger of getting burnt if you are not careful enough!**

**The warning sign** 

This warning sign appears in the manual when the health or property is threatened, in case that the instructions are not exactly kept.

**Two types of the warning signs and symbols are used in this manual:**



**WARNING** – Information about the potentially dangerous situation that could cause serious threat to health or property if advised actions are not taken.



**CAUTION** – Warns about the less safe way of work and procedures that may cause health injury or material damage.

# 1 INTRODUCTION

**Dear customer,**

thank you for your trust and purchase of our product – the ATTACK wood gasifying boiler. We wish it serves you reliably for a long time. The reliable and correct function of device is related to its operation and therefore it is necessary to read this user manual. The manual is written with respect to the correct function of the boiler.

**The correct function of the boiler particularly depends on the following:**

- choice of the correct boiler output and type
- perfect commissioning
- reasonable operation
- regular professional maintenance
- reliable service

## 1.1 GENERAL DESCRIPTION

|                                 |  |
|---------------------------------|--|
| <b>Wood gasifying boiler</b>    | ATTACK DPX   |
| <b>Name:</b>                    | WOOD GASIFYING BOILER ATTACK DPX 15, 25, 30, 35, 40, 45, 80, 100<br>IN VERSION „STANDARD“, „PROFI“, „LAMBDA“ |
| <b>Type:</b>                    | ATTACK DPX 15, 25, 30, 35, 40, 45, 80, 100   |
| <b>Max. operating pressure:</b> | 250 kPa  |
| <b>Volume of water:</b>         | 80, 100, 110, 128, 250 l   |
| <b>El. power supply:</b>        | 230 V/50 Hz/10 A   |
| <b>E. input:</b>                | 32 – 90 W  |
| <b>Fuel:</b>                    | Dry wood with heat value of 15–17 MJ/kg, moisture of 12 – 20 %, diameter of 80 – 150 mm                      |
| <b>Nominal output:</b>          | 15, 25, 30, 35, 40, 45, 80, 100 kW   |

The wood gasifying boiler ATTACK DPX is intended for economical and ecological heating of family houses, cottages, small plants and similar objects.

## 1.2 MARKING OF THE BOILERS ATTACK DPX

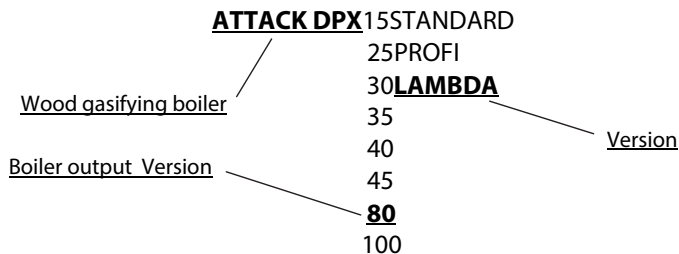

## 1.3 TECHNICAL PARAMETERS

| Boiler type  | Unit                          | DPX15  | DPX25     | DPX30   | DPX35     | DPX40   | DPX45     | DPX80   | DPX100  |
|--|-------------------------------|--|-----------|---------|-----------|---------|-----------|---------|---------|
| Nominal output (version STANDARD)                                | kW                            | 15   | 25        | 30      | 35        | 40      | 45        | 80      | 100     |
| Output range (version PROFI, LAMBDA)                             | kW                            | 7,5 – 15   | 12,5 – 25 | 15 – 30 | 17,5 – 35 | 20 – 40 | 22,5 – 45 | 32 – 80 | 40-100  |
| Area of exchanger  | m <sup>2</sup>                | 1,98   | 2,52      | 2,78    | 2,78      | 3,03    | 3,03      | 5,6     | 5,6     |
| Volume of the feeding chamber                                    | dm <sup>3</sup>               | 82   | 125       | 158     | 158       | 190     | 190       | 440     | 440     |
| Dimensions of the feeding opening                                | mm                            | 235×445  | 235×445   | 235×445 | 235×445   | 235×445 | 235×445   | 292×542 | 292×542 |
| Prescribed chimney draught                                       | Pa                            | 23   | 23        | 23      | 23        | 23      | 23        | 35      | 35      |
| Max. operating overpressure of water                             | kPa                           | 250  | 250       | 250     | 250       | 250     | 250       | 250     | 250     |
| Pressure loss of water (ΔT 10K)                                  | kPa                           | 1,9  | 2,3       | 4,4     | 4,4       | 6,6     | 6,6       | 2,1     | 2,1     |
| Pressure loss of water (ΔT 20K)                                  | kPa                           | 0,6  | 0,7       | 1       | 1         | 1,8     | 1,8       | 0,55    | 0,55    |
| Boiler weight  | kg                            | 370  | 430       | 460     | 460       | 490     | 490       | 800     | 800     |
| Diameter of flue connection                                      | mm                            | 150  | 150       | 150     | 150       | 150     | 150       | 200     | 200     |
| Boiler height – „A“  | mm                            | 1 240  | 1 240     | 1 240   | 1 240     | 1 240   | 1 240     | 1 575   | 1 575   |
| Boiler width – „B“   | mm                            | 700  | 700       | 700     | 700       | 700     | 700       | 915     | 915     |
| Boiler depth – „C“   | mm                            | 840  | 1 240     | 1 340   | 1 340     | 1 440   | 1 440     | 1 890   | 1 890   |
| Depth of chamber – „D“   | mm                            | 400  | 590       | 690     | 690       | 790     | 790       | 1 100   | 1 100   |
| Diameter of flow connection                                      | "                             | G 6/4"   |           |         |           | G 2"    |           |         |         |
| Diameter of return connection                                    | "                             | G 6/4"   |           |         |           | G 2"    |           |         |         |
| Grade of protection  | IP                            | 21   |           |         |           |         |           |         |         |
| Electrical input   | W                             | 32   | 38        | 48      | 54        | 54      | 78        | 90      | 90      |
| Boiler efficiency  | %                             | 91,3   | 90,4      | 90,1    | 90,1      | 90,2    | 90,2      | 86,5    | 87      |
| Boiler class by CO (under the norm EN 303-5)                     | –                             | 5  |           |         |           |         |           |         |         |
| Flue gas temperature by nominal output                           | °C                            | 170  | 170       | 180     | 180       | 190     | 190       | 204     | 205     |
| Flue gas flow by nominal output                                  | kg/s                          | 0,019  | 0,019     | 0,021   | 0,021     | 0,027   | 0,027     | 0,045   | 0,05    |
| Maximum noise level  | dB                            | 65   |           |         |           |         |           |         |         |
| Prescribed fuel  | –                             | Wood logs with relative humidity min. 12 % – max. 20 %, Ø80 – 150 mm |           |         |           |         |           |         |         |
| Average fuel consumption   | kg <sup>h</sup> <sup>-1</sup> | 3,9  | 6,5       | 7,8     | 9,1       | 10,4    | 11,75     | 21,5    | 26,8    |
| Consumption per season   | –                             | 1 kW = 0,9 m <sup>3</sup>  |           |         |           |         |           |         |         |
| Maximum length of wood logs                                      | mm                            | 350  | 550       | 650     | 650       | 750     | 750       | 1 000   | 1 000   |
| Burning time by nominal output                                   | hod.                          | 3  | 3         | 3       | 3         | 3       | 3         | 3       | 3       |
| Volume of water in the boiler                                    | l                             | 80   | 100       | 110     | 110       | 128     | 128       | 250     | 250     |
| Minimum volume of accumulation tank                              | l                             | 375  | 625       | 750     | 900       | 1 000   | 1 200     | 2 000   | 2 500   |
| Connection voltage   | V/Hz                          | ~230/50  |           |         |           |         |           |         |         |
| Range of setting the temp. of heating water                      | °C                            | 65 – 90  |           |         |           |         |           |         |         |
| Range to set the room temperature                                | °C                            | 10 – 27  |           |         |           |         |           |         |         |
| Capacity of contacts of the boiler regulator (the PROFI version) | –                             | 2 A/230 V  |           |         |           |         |           |         |         |

Level of the acoustic pressure A does not exceed 70 dB (A).

Instant peak value of the acoustic pressure C does not exceed 63Pa.

Prescribed min. temperature of return water during the operation is 65 °C.

Prescribed operating temperature of water in the boiler is 80 – 90 °C.

*Producer, the ATTACK, s.r.o. reserves right to make technical changes of products without the previous announcement!*

## 1.4 DIMENSIONS OF THE BOILERS ATTACK DPX

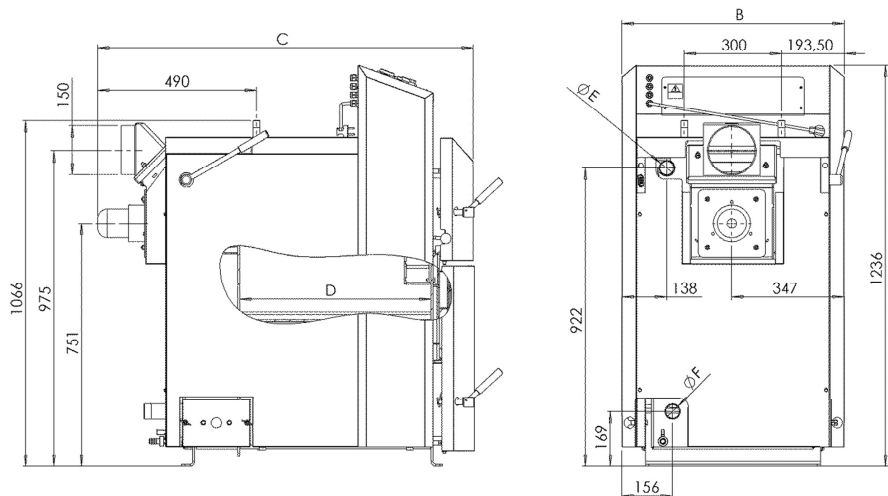

|                         | DPX15 | DPX25 | DPX30 | DPX35 | DPX40 | DPX45 |
|-------------------------|-------|-------|-------|-------|-------|-------|
| Flow connection – „E”   | G6/4” | G6/4” | G6/4” | G6/4” | G2”   | G2”   |
| Return connection – „F” | G6/4” | G6/4” | G6/4” | G6/4” | G2”   | G2”   |

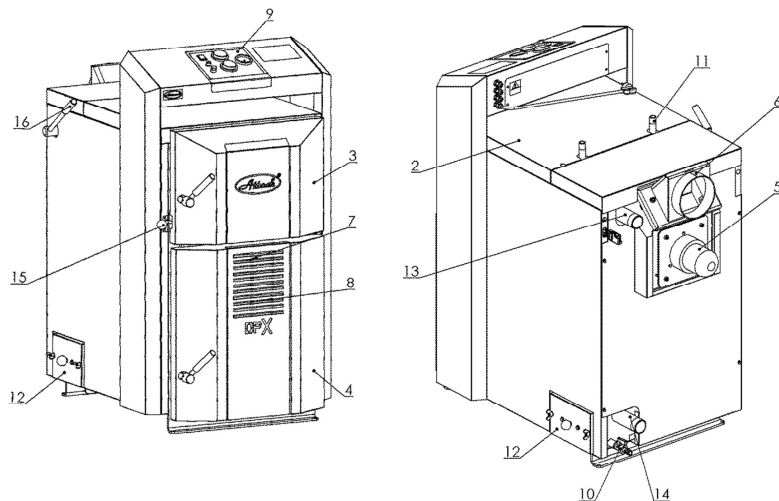

### KEY:

- |                  |                          |                                 |                                  |
|------------------|--------------------------|---------------------------------|----------------------------------|
| 1. Boiler body   | 5. Suction fan           | 9. Control panel                | 13. Flow connection              |
| 2. Upper cover   | 6. Chimney               | 10. Drain valve                 | 14. Return connection            |
| 3. Feeding door  | 7. Flap of primary air   | 11. Cooling circuit             | 15. Pull rod of the chimney flap |
| 4. Ash tray door | 8. Flap of secondary air | 12. Lid of the cleaning opening | 16. Lever for exchanger cleaning |

## 1.5 DIMENSIONS OF THE BOILER ATTACK DPX 80, 100

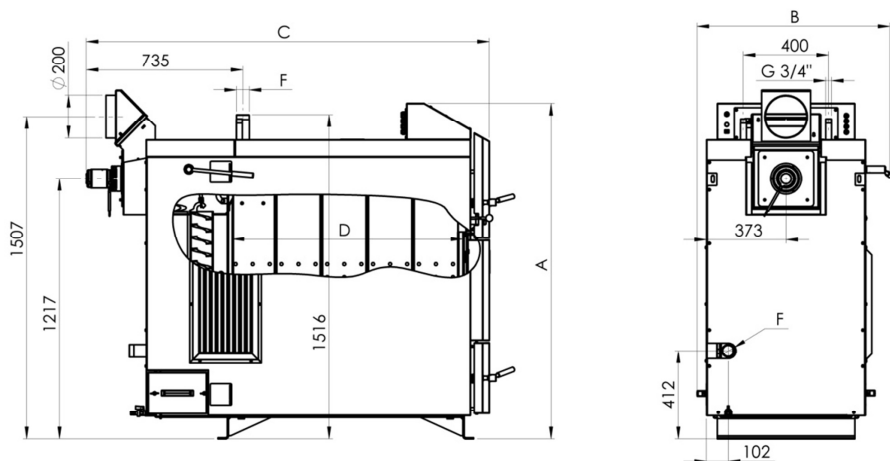

|                         | DPX80, 100 |
|-------------------------|------------|
| Flow connection – „E“   | G2“        |
| Return connection – „F“ | G2“        |

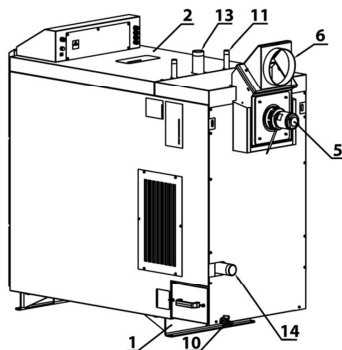
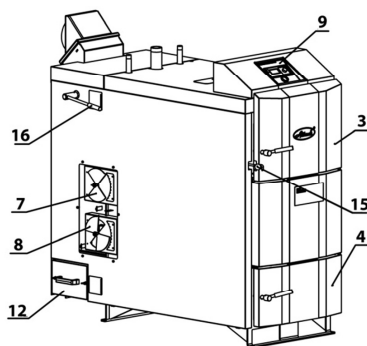

### KEY:

- |                  |                          |                                 |                                  |
|------------------|--------------------------|---------------------------------|----------------------------------|
| 1. Boiler body   | 5. Suction fan           | 9. Control panel                | 13. Flow connection              |
| 2. Upper cover   | 6. Chimney               | 10. Drain valve                 | 14. Return connection            |
| 3. Feeding door  | 7. Flap of primary air   | 11. Cooling circuit             | 15. Pull rod of the chimney flap |
| 4. Ash tray door | 8. Flap of secondary air | 12. Lid of the cleaning opening | 16. Lever for exchanger cleaning |

## 1.6 CONTROL PANEL

### 1.6.1 ATTACK DPX STANDARD

The wood gasifying boiler "ATTACK DPXSTANDARD" is controlled by the boiler and the flue gas thermostat.

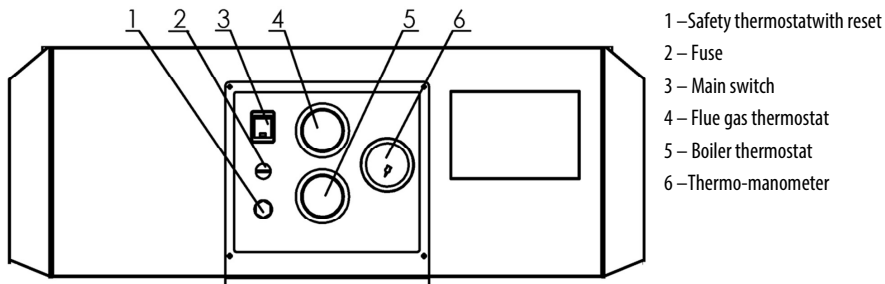

#### Description:

1. **Safety thermostat with reset** – boiler protection against overheating (after exceeding the temperature of 110 °C is the boiler disconnected from electricity mains). After the temperature decreases below 85 °C, it is necessary to undo the reset cover and to press the restart button manually.
2. **Fuse** – boiler protection against short circuit
3. **Main switch** – boiler start and stop for the case of need
4. **Flue gas thermostat** – the fan is stopped after the flue gas temperature decreases below the adjusted value



**ATTENTION!** Set this thermostat to 0 °C by heating up. After the fuel starts to burn, set the flue gas thermostat to the „Operation“ position. When the temperature decreases under the adjusted value, the exhaust fan is stopped. To start the fan again, set the lower temperature value on the thermostat. The optimal setting for operation will be found by experience.

5. **Boiler thermostat** – serves to set the max. temperature of water in the boiler (After exceeding the adjusted temperature is the fan stopped and the boiler works at min. output. After the temperature decreases below the adjusted value, the fan is started again and the boiler works at max. output).
6. **Thermo-manometer** – shows the output temperature of water from the boiler and the operating pressure

**Pull rod of the chimney flap** – serves to close and to open the heat up flap (always by opening the feeding door)

**Lever for exchanger cleaning** – serves to clean the holes of the exchanger

## 1.6.2 ATTACK DPX LAMBDA

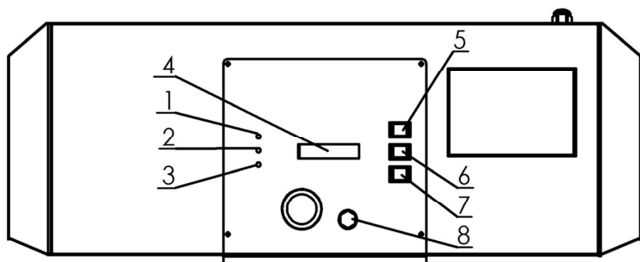

**Key:**

1. – Green indicator light
2. – Yellow indicator light
3. – Red indicator light
4. – Display
5. – Button „+“
6. – Button „-“
7. – Button „←“
8. – Reset of the safety thermostat

- Indicator light 1: Lights, when the boiler was started by the button „+“ (5) automatically stops after the fuel burns down or when the boiler was manually stopped by the button „-“ (6).
- Indicator light 2: Lights in case of the following faults:
- *incorrectly measured values of the flue gas temperature*
  - *see the chapters **Errors and alarms***
- Indicator light 3: Lights or flickers in the case of error or alarm:
- *STB started–Reset (error, message (3) displayed)*
  - *incorrectly measured values of the boiler temperature (error, message (3) displayed)*
  - *too high flue gas temperature (alarm, message (3) displayed)*
  - *overheating – do not open! (boiler temperature over 90 °C, display 3 flickers)*
  - *see the chapter **Errors and alarms***
- Display 4: Displays the operating data for different settings by errors. If the boiler is stopped and no fault is displayed, the display illumination is turned off after 15 minutes.
- Button 5 (+): The display illumination is turned on after pressing the button for the first time. The boiler is started after the button is pressed again – then it is possible to heat it up or to refill the fuel. Also other settings can be done by this button (see the Button 7 below).
- Button 6 (-): Serves to stop the boiler. This function is used only for an emergency stop, e.g. if there is no water in the heating system or is the sensor for overheating is not working. Also other settings can be done by this button (see the Button 7 below).
- Button 7 (←): The display illumination is turned on after pressing the button for the first time. Press the button again to get into the „Options“. Use the buttons „+“ (5) or „-“ (6) to get to the various data or to make settings.
- !There are various functions of the buttons 5 and 6.**
- Button 8: *Reset the button of the safety thermostat (STB)*  
 If the STB had been started because of the excessive boiler temperature ( $\geq 95^{\circ}\text{C}$ ) and the boiler temperature decreased to  $85^{\circ}\text{C}$ , you can reset the STB by removing the cover (8) and pressing the button underneath (8). The error is automatically removed. If the error occurs again, inform the technician.



Reasons: small outtake of heat, power shortage, circuit pump – faulty mixing valve. To decrease the temperature to 85 °C, the regulator starts the supply pump.



**If the flue gas fan does not work, do not open the boiler door!**

## 1.7 PURPOSE OF USE

The ecological warm water boiler ATTACK DPX is intended for heating the family houses and other similar objects. The boiler is designed only for the use of wood logs. Any type of dry wood can be used, especially the wood logs. It is also possible to use the blocks of wood with larger diameter – then is the boiler output lower, but the time of burning is longer. The boiler is not suitable to burn the saw dust and small wooden waste. Only small amount (approximately 10 %) of such a material can be used together with the wood logs. Thanks to the voluminous feeding chamber it is not necessary to do the most demanding work with wood – chopping into smaller pieces.



**It is not allowed to place the boiler in residential premises (including corridors)!**

## 1.8 TECHNICAL DESCRIPTION

The boiler is designed to burn wood on principle of the wood gasification by using the exhaust fan that sucks the flue gas from the boiler.

The boiler body is welded from the steel plates of 6 mm thickness. In the feeding chamber there is a fireproof nozzle with longitudinal opening for the flue gas and gas passage.

In the burning chamber there is a fireproof ashtray. In the rear part of the boiler body is the tubular exchanger with the flue gas collector and the heat up flap in the upper part. There is also the flue connection in the rear part.

In the front parts there is a feeding door and at the bottom there is the ashtray door.

Between the doors there are the primary and secondary air inlets placed under the boiler covering.

In the left covering at the same level as the middle of the feeding door there is a pull rod of the heat up flap that is controlled by the feeding door and there is also the lever for exchanger cleaning. The boiler body is insulated by a mineral wool, inserted under the external covering. The control panel for electromechanical regulation is placed in the upper part of the boiler.

## 2 TECHNICAL DESCRIPTION OF THE ATTACK DPX STANDARD

### 2.1 OPERATING PRESCRIPTIONS

#### Boiler preparation for operation

Before starting the boiler, it is necessary to check that the system is filled with water, deaerated and the pressure of heating water does not decrease. Make sure that the sensors of the boiler, safety thermostat and manometer are placed in casings on the upper rear side of the boiler. Check the tightness and construction of the flue connection. The boiler has to be operated in line with the instructions given in this manual to achieve its good service. By boiler installation you can underlay it for 10 mm to enable better flush by water and deaeration. Only an adult trained person with completed elementary education can operate the boiler.

#### Caution

By the first heat up it may come to condensation and leakage of the condensate – it is not a fault. There will be no more condensate after heating for a longer time. In the case that the smaller wooden waste is being burned, it is necessary to check the flue gas temperature which should not exceed 320 °C. Otherwise it could damage the fan. By the gasification of wood it is normal that tar and condensates are created.

If the boiler has been out of order for a longer period, it is necessary to be more careful by starting it again. It could come to the pump blockage, leakage of water from the system or to the boiler freezing in the winter.

#### Heating up and operation

Before igniting the fuel, open the feeding door and push the pull rod of the heat up flap back to the basic position until is the latch fixed (like when the door is closed, see the picture).

Position after the feeding door is open.

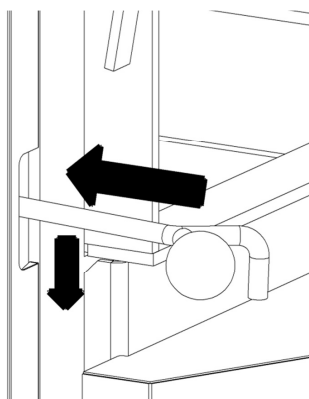

Press backwards and downwards

Position after pressing backwards and downwards

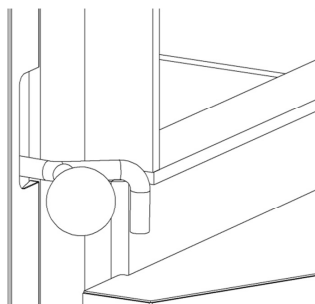

Turn the flue gas thermostat to „0 °C“. Put one layer of the medium thick wood logs (of approx. 50 mm length) through the upper door on a fire proof nozzle. Then, make the layer of thin wood with the gap of 2 – 4 cm and lay splinters or wood wool and paper on it. Continue with 2 layers of thin dry wood and complete it with the standard firewood. Turn the exhaust fan on and after the wood is ignited, let the feeding door open for approximately 15 mm. Use the output regulator to set the required water temperature (80 – 90 °C). When the fire is strong enough (after approximately 10 minutes), close the feeding door. Set the flue gas thermostat to the operating temperature (white mark upwards, approximately 90° to the right from the zero position – it depends on the flue gas temperature required to stop the boiler after the fuel burns out).



**WARNING: The pull rod of the heat up flap has to be pushed backwards to close the heat up flap. Otherwise the fan could get damaged.**

For wood gasification in the boiler it is necessary to keep the reduction layer during the operation (the layer of wood coal on the nozzle in the feeding chamber). Therefore it is necessary to burn dry wood of a suitable size. When the wet wood is burned, the boiler does not work as a wood gasifying boiler, the wood consumption rises, the output is not sufficient and service life of the boiler and of the chimney is shortened.

When there is a prescribed chimney draught, the boiler works up to 70 % of its output even without the fan.

### **Electromechanical boiler regulation**

The boiler is regulated by the boiler thermostat placed on a boiler panel which controls the fan according to the adjusted output temperature of water. The required operating boiler temperature should be set on the boiler thermostat. The flue gas thermostat placed on a panel serves to stop the fan after the fuel burns out. Set the flue gas thermostat to „0 °C“ when heating up. When the fire is sufficient, set it to the operating position to let the fan run and to stop it after the fuel burns out. The optimal position of the flue gas thermostat has to be found by experience, adequately to the fuel used, chimney draught and other conditions. The output temperature of water is indicated on thermo-manometer. The irreversible safety thermostat is also placed on the front panel (the STANDARD and LAMBDA version).

### **Refilling the fuel**

When refilling the fuel, open the feeding door. The heat up flap is opened at the same time. Do not stop the fan. Always keep the feeding chamber full when heating up. Not to let the smoke flow into the boiler room, refill the fuel after it is burned to approximately 1/3 of the feeding chamber. Cover the glowing coal with a wide wood log and refill the fuel normally. Do not press the fuel on the nozzle, otherwise it could get clogged and the parameters of burning would be worse.

## 3 TECHNICAL DESCRIPTION OF THE ATTACK DPX PROFI

The ATTACK PROFI boiler version in comparison with the ATTACK STANDARD version brings the higher comfort of operation, option of output regulation and option to connect the control and regulation devices.

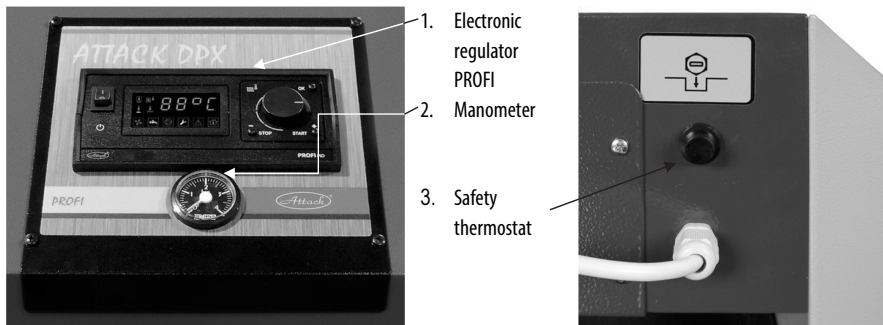

### 3.1 ADVANTAGES OF THE REGULATOR

The ATTACK PROFI PID is a sophisticated regulator for wood gasifying boilers DPX. There is an improvement of regulation – the flue gas temperature is controlled by the PID.

#### **The regulator can control:**

1. Rotations of flue gas fan
2. Circuit pump of heating circuits
3. Pump for warming the D.H.W. or pump for warming the accumulation tank (always just one)
4. Starting another, automatic boiler, if the fuel in the boiler burned out

#### **The regulator measures the following:**

1. Boiler temperature
2. Flue gas temperature
3. Temperature in the D.H.W. tank or in the accumulation tank (always just one)
4. Room thermostat and thereby it controls the circuit pump

### 3.2 BASIC DESCRIPTION OF THE REGULATOR

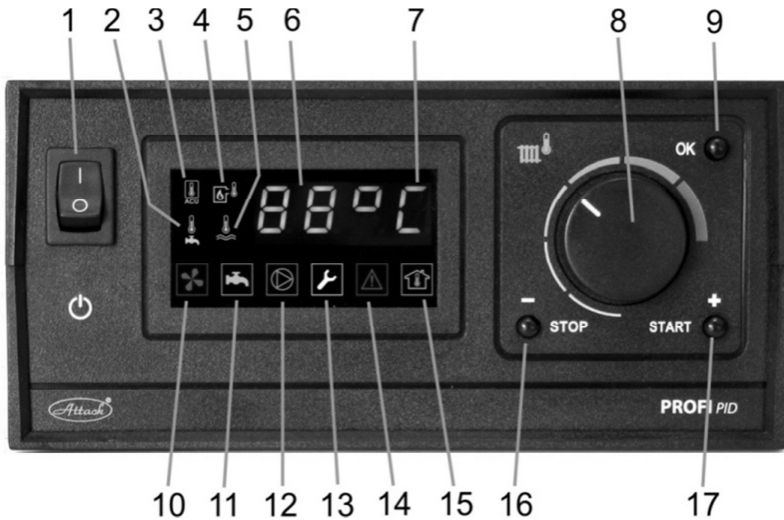

#### KEY:

1. main switch
2. icon for D.H.W. temperature
3. icon for temperature of accumulation tank
4. icon for flue gas temperature indication
5. icon for current boiler temperature
6. current boiler temperature (or temperature of D.H.W., flue gas, etc.)
7. sign for boiler operating mode
8. setting the boiler temperature
9. button to enter into the information menu, service menu and confirmation of parameters
10. icon for fan operation
11. operation of the pump for D.H.W. or for accumulation tank warming
12. icon for circuit pump operation
13. icon for enter into the service menu
14. icon indicating overheating or damaged sensors
15. icon indicated that the room thermostat is started
16. button to stop the boiler or to move backwards in menu
17. button to start the boiler or to move forwards in menu

### 3.3 CONNECTION OF THE REGULATOR BY HYDRAULIC SCHEMES

The regulator can control several types of hydraulic schemes. Parameters in the service menu must be correctly set adequately to the type of the hydraulic scheme.

**Note:** Correct connection of the pumps and sensors is given on schemes. Connection of the fan and connection of the regulator to the electricity mains is not drawn.

#### 3.3.1 WOOD GASIFYING BOILER + HEATING CIRCUIT

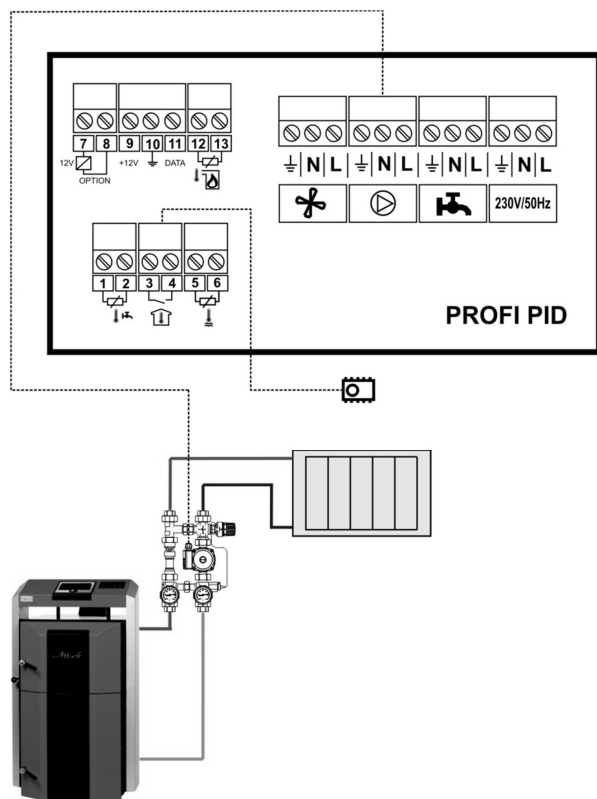

**Parameter setting for the hydraulic scheme 3.1:**

ur = ur0

### 3.3.2 WOOD GASIFYING BOILER + HEATING CIRCUIT + WARMING OF D.H.W.

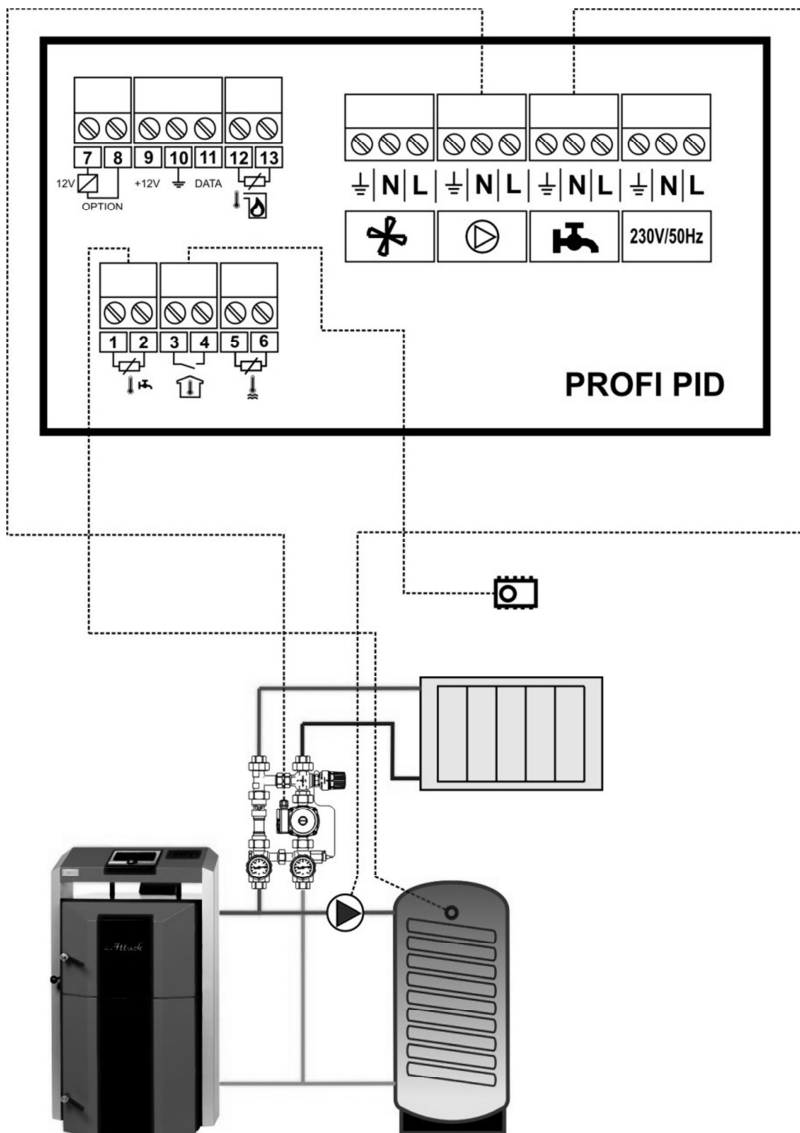

**Parameter setting for the hydraulic scheme 3.2:**

- ur = ur1 –for priority charging of the D.H.W. tank
- ur = ur2 –for parallel charging the D.H.W. tank

### 3.3.3 WOOD GASIFYING BOILER + HEATING CIRCUIT + WARMING OF ACCUMULATION TANK

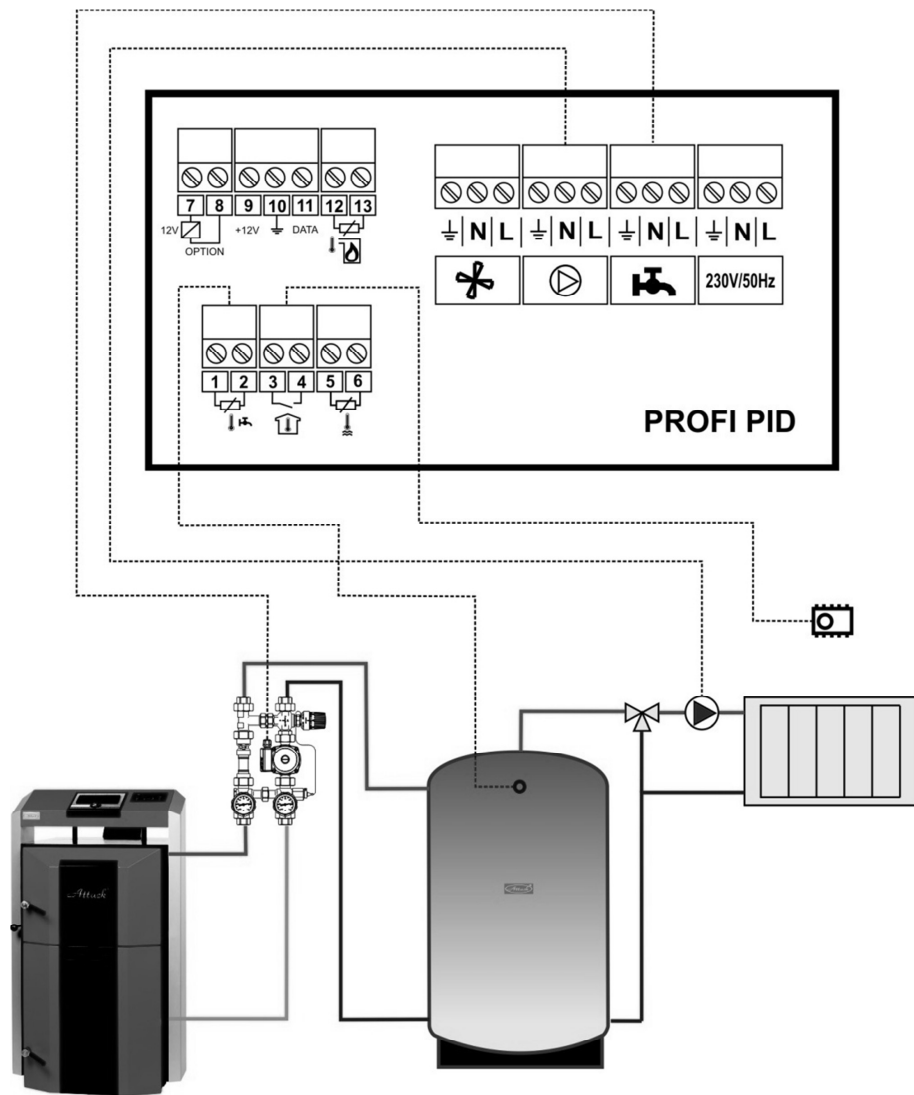

**Parameter setting for the hydraulic scheme 3.3:**

ur = ur4



### 3.3.4 WOOD GASIFYING BOILER + HEATING CIRCUIT + WARMING OF ACCUMULATION TANKS CONNECTED IN SERIE

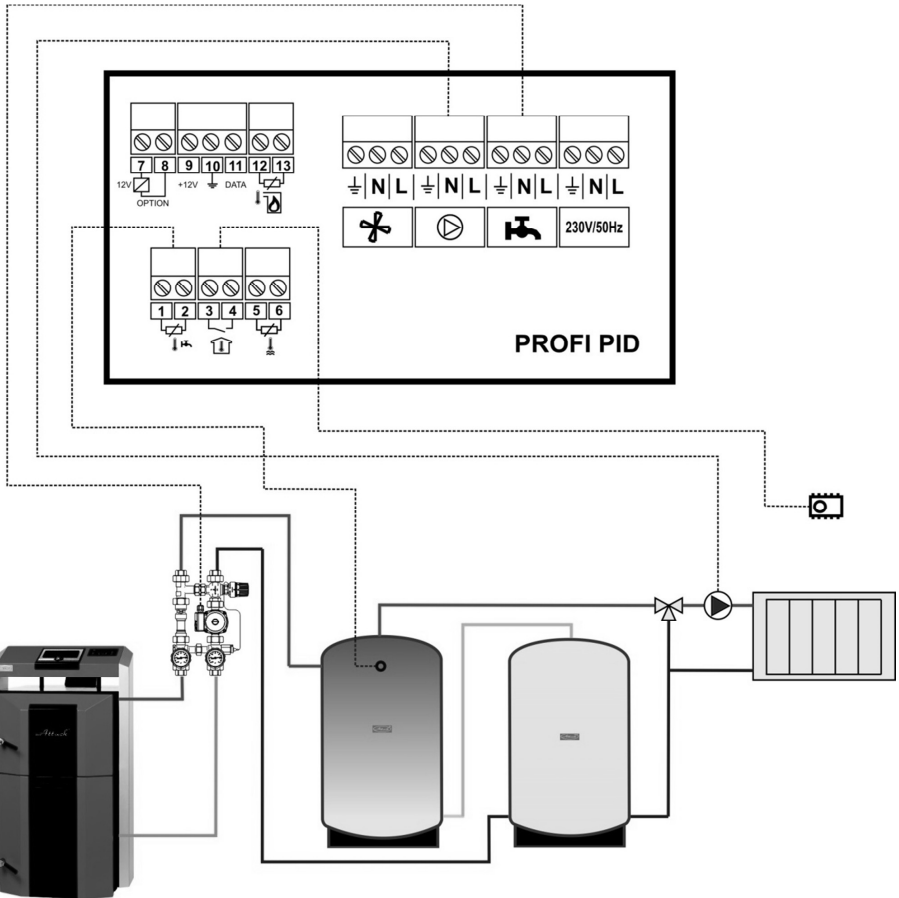

**Parameter setting for the hydraulic scheme 3.4:**

ur = ur4

### 3.3.5 WOOD GASIFYING BOILER + HEATING CIRCUIT + WARMING OF THE COMBINED ACCUMULATION TANK

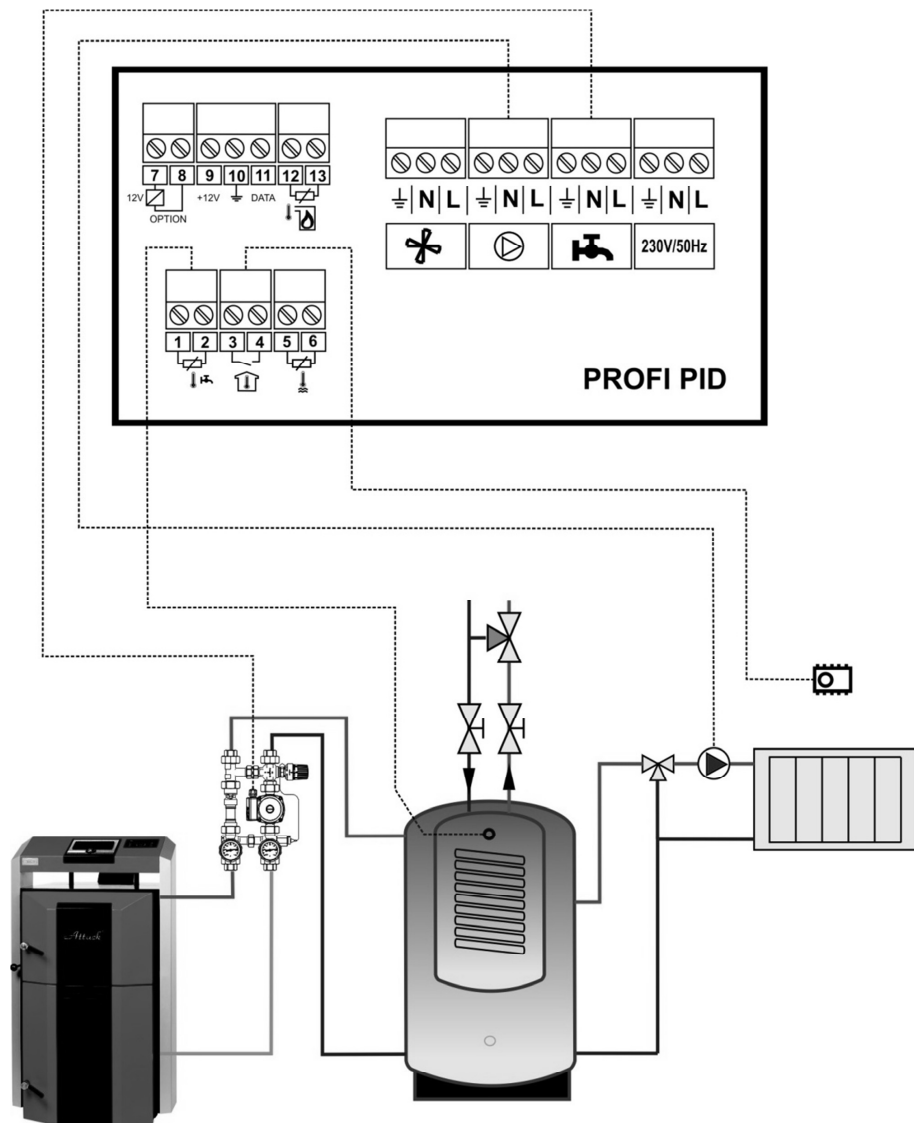

**Parameter setting for the hydraulic scheme 3.5:**

ur = ur4

### 3.4 REGULATOR CONTROL AND OPERATING MODES

Turning on the controller is signalized by a brief switching on all the light indicators on display to enable to check their status. If the regulator gets suddenly disconnected from electricity mains (e.g. by power failure), it is switched to the last mode used, when the failure occurred. All the settings made are saved even after the power failure.

The basic setting of the controller is the adjustment of the boiler temperature by the knob. Other functions are controlled adequately to the service parameters set in the service menu.

The boiler is turned on by pressing the START (17) button that starts the fan. The STOP (16) button switches the boiler off by turning the fan off.

**The sign displayed behind the numeric temperature indication (7) is related to the current mode of the PID PROFI regulator:**

[50°-] – indicates the stand-by mode

[50 °C] – indicates the winter operating mode

[50 °C] – indicates the winter operating mode when the boiler temperature is achieved

[50°U] – indicates summer operating mode intended only for D.H.W. preparation

[50°u] – indicates summer operating mode when the boiler temperature is achieved

[70°d] – indicates mode of elimination the legionella bacteria, when the temperature of D.H.W. is increased to 75 °C

[50°P] – indicates that regulator is blocked by pellet burner of the COMBI Pellet boiler

The PROFI PID regulator has an advantage of regulating the flue gas temperature to the required value. The controller struggles to achieve the adjusted flue gas temperature and after it is achieved, the required boiler temperature is to be reached. Thereby is the fuel used in the best way and the high efficiency is achieved.

## 3.5 SETTING THE USER PARAMETERS

The menu for displaying and setting the user parameters is accessible after short pressing of the OK button. The „+“ and „-“ buttons are used to browse in settings and parameters. The appropriate parameter selected becomes adjustable by the „OK“ button and starts to flicker. Then it can be changed by the „+“ and „-“ button and confirmed by „OK“. Some of the parameters are only informative and they cannot be changed. To exit the menu, confirm the [End] by „OK“ button. After remaining more than 1 minute without the user’s intervention, the controller switches the display to the basic mode.

**Table 2. User parameters:**

| Indication | Parameter  | Min | Max | Step | Prod. setting |
|------------|--|-----|-----|------|---------------|
| C 45       | Adjusted boiler temperature  | L65 | H90 | 1 °C | –             |
| co C       | Operating mode of the circuit pump ('C' – WINTER, '-' – SUMMER)                            | C   | –   |      | C             |
| cu u       | Operation of the D.H.W. pump ('u' – casual mode, 'd' – elimination of legionella bacteria) | u   | d   |      | u             |
| u50°       | Current temperature measured in the accumulation tank or D.H.W. tank                       |     |     |      |               |
| 150°       | Current flue gas temperature   |     |     |      |               |
| End        | Exit from user parameters  |     |     |      |               |

**[C 45] – Adjusted boiler temperature**– this is the value of boiler water temperature the regulator is going to reach while in the WORK mode. It is set by turning the thermostat knob manually (8) and shown briefly on the display (6).

**[co C] – WINTER/SUMMER mode** – the winter mode is indicated by the 'C' letter. Then is the circuit pump controlled by the room thermostat and distributes the heat into the heating system. The summer mode is indicated by the „-“ sign. Then is the circuit pump out of order and the heat generated by boiler is only used to heat the D.H.W. tank. If there is not D.H.W. tank in the system (additional sensor is not connected), it is not possible to select the SUMMER / WINTER mode.

**[cu u] – Mode of D.H.W. tank warming** –the regulator enables the casual D.H.W. tank warming „u“ or the mode to eliminate the legionella bacteria „d“. After the „d“ mode is selected, the temperature of 75 °C is achieved in the D.H.W. tank. When this temperature is achieved, the controller switches into the mode of the casual D.H.W. tank warming „u“. The option of elimination the legionella bacteria is not available, if the additional outlet and sensor are not set for the D.H.W. warming.



**CAUTION!** Not to get hurt by the hot water, it is recommended to set this mode, when the D.H.W. is not being used (e.g. during the night).

**[u50°] Temperature of additional sensor**– this is the value of current temperature of the D.H.W. tank or of the accumulation tank of the heating system. This temperature is not displayed in the user menu, if the additional output is not used.

**[150°]Flue gas temperature** – this value represents the current temperature of flue gas, if the parameter for flue gas temperature is set in the service parameters.

### 3.6 SETTING THE SERVICE PARAMETERS

By holding the OK button you get into the service menu to the parameter settings (the icon (13)). The buttons „+“ and „-“ are used to browse in particular parameters. After selecting the appropriate parameter, it is confirmed by „OK“ button and starts to flicker. To exit the menu, confirm the [End] by „OK“ button. After remaining for more than 1 minute without the user's intervention, the controller switches the display to the basic mode.

**Table 3. Service parameters:**

| <b>SERVICE MENU</b> (available by holding the OK button) |   |            |            |             |                   |
|--|---|------------|------------|-------------|-------------------|
| <b>Display</b>   | <b>Parameter</b>  | <b>Min</b> | <b>Max</b> | <b>Step</b> | <b>Prod. set.</b> |
| <b>Π100</b>  | Maximum fan output  | 1          | 100        | 1%          | 100               |
| <b>n 40</b>  | Minimum fan output  | 1          | 100        | 1%          | 40                |
| <b>Πh 5</b>  | Ratio of changing the fan rotations                       | 2          | 20         | 1           | 5                 |
| <b>Πr 0</b>  | Automatic regulation of changing the fan rotations        | --, 0      | 10         | 1           | 0                 |
| <b>Πt 1</b>  | Delay of changing the fan rotations                       | 0          | 99         | 1           | 1                 |
| <b>Πn 5</b>  | Frequency of exhaust fan blow-through                     | --, 5      | 60         | 1s          | 5                 |
| <b>Πu 6</b>  | Duration of exhaust fan blow-through                      | 1          | 99         | 1min        | 6                 |
| <b>Πd3</b>   | Duration of manual fan operation for 100%                 | --, 1      | 99         | 1min        | 3                 |
| <b>r100</b>  | Fan output by ignition                                    | 1          | 100        | 1%          | 100               |
| <b>rh 5</b>  | Hysteresis of boiler stop by ignition                     | 1          | 45         | 1 °C        | 5                 |
| <b>P 30</b>  | Temperature to start the circuit pump                     | --, 20     | 70         | 1 °C        | 30                |
| <b>Ph 2</b>  | Hysteresis of circuit pump                                | 1          | 40         | 1 °C        | 2                 |
| <b>Pc --</b>   | Interval of unlock function of circuit pump               | --, 1      | 99         | 1min        | 2                 |
| <b>ur4</b>   | Operation of additional output                            | 0          | 4          | 1           | 4                 |
| <b>u30</b>   | Operating temperature of D.H.W. tank or accumulation tank | 30         | 60         | 1 °C        | 30                |
| <b>uh 5</b>  | Hysteresis of D.H.W. tank of accumulation tank            | 1          | 30         | 1 °C        | 5                 |
| <b>uP 5</b>  | Boiler temperature increase by D.H.W. warming             | 1          | 20         | 1 °C        | 5                 |
| <b>L65</b>   | Minimum boiler temperature                                | 30         | 65         | 1 °C        | 65                |
| <b>H 85</b>  | Maximum boiler temperature                                | 80         | 95         | 1 °C        | 85                |
| <b>H 2</b>   | Boiler temperature hysteresis                             | 1          | 10         | 1 °C        | 2                 |
| <b>A 99</b>  | Temperature of boiler overheating                         | 90         | 99         | 1 °C        | 99                |
| <b>Fd60</b>  | Duration of boiler stop by ignition and fuel shortage     | --, 1      | 99–4h      | 1min        | 60                |
| <b>Fb30</b>  | Duration of boiler stop by flue shortage and burn-down    | --, 1      | 99–4h      | 1min        | 30                |
| <b>Ar 0</b>  | Control of multifunctional additional output              | 0          | 1          | 1           | 0                 |
| <b>c 240</b>   | Adjusted flue gas temperature                             | -0,5       | 250        | 1 °C        | 240               |
| <b>ch5</b>   | Flue gas temperature hysteresis                           | 1          | 99         | 1 °C        | 5                 |
| <b>ct 5</b>  | Time constant of stabilization the flue gas temperature   | 1          | 99         | 1 min       | 5                 |
| <b>c F10</b>   | Blower speed jump while stabilizing flue gas temperature  | 1          | 20         | 1 °C        | 10                |
| <b>c 90</b>  | Flue gas temperature by fuel shortage                     | 30         | 150        | 1 °C        | 90                |
| <b>c 300</b>   | Maximum flue gas temperature                              | 250        | 400        | 1 °C        | 300               |
| <b>Prod</b>  | Reset of production settings                              |            |            |             |                   |
| <b>outΠ</b>  | Test of fan relay   | outΠ       | out1       |             |                   |
| <b>outP</b>  | Test of circuit pump relay                                | outP       | out2       |             |                   |
| <b>outu</b>  | Test of relay of optional pump                            | outu       | out3       |             |                   |
| <b>outr</b>  | Test of additional output                                 | outr       | out4       |             |                   |
| <b>End</b>   | Exit to main menu   |            |            |             |                   |

## 3.7 DESCRIPTION OF PARAMETERS

**[П100]Maximum fan output** – the highest fan output possible

**[n 40]Minimum fan output** – the lowest fan output possible

**[Ph 5]Ratio of changing the fan rotations** – this parameter influences the fan rotations, if the adjusted boiler temperature is going to be achieved in a short time. For example, if the value 4 is set, the fan will work at full output [П100] (if the function of flue gas temperature control is not active), up to 4 degrees before achieving the required boiler temperature. Then, by every increase of the boiler temperature for 1 °C, the fan rotations are gradually decreased until the minimum fan output is reached [n 40].

**[Пr 0]Automatic regulation of changing the fan rotations** – the fan rotations are increased / decreased by setting this parameter within the range of 0 – 10 to ensure the required boiler temperature. If this parameter is set to „-“, the rotations are not controlled and the fan works at full output according to the parameter [П100]. Setting the parameter within the range of 0 – 10 relates to the time period (in minutes), during which are the fan rotations gradually increased from the parameter of the minimum fan rotations [n 40] up to the parameter [r 100]. This ensures the fluent heat-up of boiler.

**[Пn 5]Frequency of exhaust fan blow-through** – this frequency defines, how often the fan is started to the full output [П100] to take the flue gas out from the boiler, if the fan was stopped due to the boiler temperature achieved.

**[Пu 6]Duration of exhaust fan blow-through** – during this period must the fan exhaust the flue gas following the parameter [Пn 5].

**[r 100]Fan output by ignition** – this parameter defines the fan output by boiler heat-up. If the parameter " Пr " is set to [Пr 0], then this parameter is not available.

**[rh 5] Hysteresis of boiler stop by ignition** – defines, how many degrees before reaching the required boiler temperature will be the heat-up phase finished or (if the flue gas temperature sensor is connected), how many degrees before reaching the required flue gas temperature are relevant to stop the heat-up phase. After deactivation of the heat-up phase there is a casual operating mode.

**[P 30]Temperature to start the circuit pump** – if there is not D.H.W. tank in the system [ur 0] or it is in the mode [ur 2], then the parameter defines the boiler temperature for starting the circuit pump of the heating system. If the parameter is set to „-“, then too low temperature does not influence the operation of the circuit pump. Anyway, the pump is always started, when the boiler temperature exceeds the parameter [H 85] of the maximum boiler temperature.

If there is accumulation tank in the system (parameter [ur 4]), then this parameter defines the temperature measured in the accumulation tank by which is the circuit pump of the heating system started.

**[Ph 2]Hysteresis of circuit pump** – defines the temperature difference under which must the boiler temperature or temperature in the accumulation tank decrease in comparison with the temperature defined by the parameter

**[P 30]** to stop the circuit pump.

**[Pc --]Interval of unlock function of circuit pump** – when controller is in the stand-by mode or the room thermostat is disconnected, the circuit pump is started for 30 seconds after each [Pc --] minutes to prevent the pump blockage caused by its inactivity. The unlock pump function is not active, when the Pc is set to „-“.

**[ur 0]Operation of the additional output** – this parameter defines the operating mode of the additional output (pump for D.H.W. tank or accumulation tank warming).

**[ur 0] Additional output without function** – defines that the additional output and pump are not connected and the additional output is not used in this case.

**[ur 1]Priority D.H.W. tank warming** – by this setting is the pump for D.H.W. tank warming connected to the additional output and the sensor of D.H.W. is connected to the additional inlet. Then, if the temperature in the D.H.W. tank decreases under the value of hysteresis [uh 5] from the temperature adjusted [u 60], the pump of D.H.W. tank warming is started. After the temperature in the D.H.W. tank reaches the set value [u 60], the pump is stopped. The pump is also stopped, when the temperature in boiler is lower than the temperature in D.H.W. tank. The [ur 1] mode means that the D.H.W. warming has priority, i.e. the pump of the heating circuit is started after the D.H.W. is prepared.

**[ur 2] Parallel charging the D.H.W. tank** – similar principle as by the [ur 1], just the D.H.W. is prepared by the parallel operation of the circuit pump of the heating circuit.

**[ur 3]Unused**

**[ur 4]Charging the accumulation tank** – due to this setting is the additional output used as a pump to heat the accumulation tank and the additional sensor measures its temperature. When the temperature in the boiler exceeds the hysteresis [uh 5] over the current temperature of accumulation tank, the pump for charging is started. The pump is stopped, when the temperature in the boiler is same or lower than the temperature in the accumulation tank, or when the temperature in boiler decreases under the minimum boiler temperature defined by the parameter [L 65].

**[ur 30] Operating temperature of the D.H.W. tank or accumulation tank** – temperature to control the additional output [ur ].

**[uh 5]Hysteresis of the D.H.W. tank or accumulation** – this parameter defines hysteresis of the additional output [ur ].

**[uP 5]Boiler temperature increase by D.H.W. preparation** – this parameter is relevant, when the additional output works under the mode of D.H.W. tank charging. It defines, for how many degrees will the adjusted boiler temperature be higher than parameter [u 50] during the D.H.W. tank warming.

**[L 65]Minimum boiler temperature** – defines the minimum boiler temperature that can be set by a knob.

**[H 85]Maximum boiler temperature** – defines the maximum boiler temperature that can be set by a knob.

**[h2] Hysteresis of boiler temperature** – defines the difference between the adjusted and the current boiler temperature for which must the boiler temperature decrease to start the controller again after the adjusted boiler temperature is achieved.

**[A 99] Temperature of boiler overheating** – defines the value of boiler temperature to activate the alarm of the boiler overheating.

**[Fd60]Duration of boiler stop by ignition and fuel shortage** – this parameter defines the maximum time between starting the controller by the START button and achieving the controller’s operating mode (reaching the flue gas temperature of [° 90]). If the temperature of [° 90] is not reached during the heating up, the fan is stopped and the alarm FUEL (fuel shortage) is displayed.

**[Fb30]Duration of boiler stop by flue shortage and burn-down**– the fuel amount test is activated in the operating mode, when the flue gas temperature decreases under the parameter [° 90] or (if the flue gas sensor is not connected) when the boiler temperature decreases under the adjusted parameter [L 45]. If the temperature does not exceed the necessary limit during this period, the controller displays FUEL alarm.

**[Ar 0] The control of the additional output**-regulator is equipped with an additional multifunctional output compatible with the options listed below (it is necessary to use the additional UM-1 module for this purpose):

- **[Ar 0] parameter** – indicates start of the automatic boiler (e.g. gas or pellet boiler). When the controller is started and the boiler generates heat, the automatic boiler is stopped. Operation of the automatic boiler is blocked by the controller in the operating mode. The automatic boiler is started by controller, when the fuel is burned down in the boiler and the FUEL alarm is displayed.
- **[Ar 1] parameter** – indicates that the additional multifunctional output will be used for error messages like boiler sensor failure, overheating or fuel shortage.

**[° 240]Adjusted flue gas temperature** – the controller will struggle to reach and to keep this value. The flue gas temperature sensor is turned off, if this parameter is set to „-“.

**[° h5]Hysteresis of flue gas temperature** – defines the difference for which must the flue gas temperature decrease to increase the fan rotations.

**[° t 5]Time constant of stabilization the flue gas temperature** – defines the period of adjusting the fan rotations during stabilization of the flue gas temperature. If the flue gas temperature exceeds the value given by the parameter [° 240], the controller starts to decrease the fan rotations gradually, until the flue gas temperature decreases to the adjusted value. If the flue gas temperature decreases to the value of flue gas temperature hysteresis, the controller starts to increase the fan rotations gradually.

**[° F10]Blower speed jump while stabilizing exhaust gas temperature** – defines the change of rotations to achieve the adjusted flue gas temperature.

**[° 90]Flue gas temperature by fuel shortage** – the message „FUEL“ for fuel shortage is displayed after the flue gas temperature decreases under this value.

### 3.8 TESTING THE REGULATOR OUTPUTS

It is possible to make a check to test the correct functionality of the regulator and devices connected. The correct function of fan is tested by selecting the **[outF]** on display and holding the „OK“ button. Test of the circuit pump is done by selecting the **[outP]**. Select the **[outu]** to start the additional output and **[outr]** for multifunctional additional output.



### 3.9 RESET OF THE REGULATOR'S PRODUCTION SETTINGS

There is a possibility to reset the production settings of the regulator by selecting the **[Prod]** in the service menu and confirming by „OK“ button. Then is the regulator set to the values given in the Table 3.

### 3.10 EXIT FROM SERVICE MENU

Select the **[End]** on display and press the „OK“ button to exit from service menu.

### 3.11 ERROR MESSAGES

The connection of all sensors of the regulator is permanently monitored. If the regulator detects that some of the sensors is not connected, the error messages are displayed. Messages about the boiler overheating or fuel shortage are also displayed.

#### **Error messages displayed**

**[FUEL]** – is displayed, when there is not enough fuel in the boiler. The sufficient amount of fuel is defined by the parameter  $c_{90}$ , where the figure 90 is related to the adjusted value 90 °C. Then, if the flue gas temperature decreases under this adjusted value within the time  $Fb_{30}$  (time of boiler stop by fuel shortage), the regulator displays the [FUEL] message. To start the boiler again, it is necessary to remove the message by the STOP button and then to press the START.

**[HOT]** – is displayed, when the flue gas temperature exceeds the maximum permitted value set by the parameter  $c_{300}$  (means 300 °C). The ventilator is stopped in this case. After the temperature decreases under the adjusted flue gas temperature, the ventilator is started again.

**[E1]** – is displayed, when the boiler temperature sensor fails or when it is not connected. In such case is the regulator taking actions to ensure the safety of the boiler – the fan is stopped (if it is currently in operation) and the circuit pump is started for eventual safe boiler cooling. After the cause of error is removed, the error message can be erased by the STOP button.

**[E2]** – is displayed, when the boiler temperature exceeds the boiler overheating temperature  $A_{99}$ . The regulator stops the flue gas fan and starts the circuit pump. The error message can be removed by the STOP button after the boiler temperature decreases to the safe value.

**[E8]** – is displayed, when the additional sensor fails (in the D.H.W. tank or accumulation tank). If this sensor works for the D.H.W. tank, the warming is blocked. If the sensor works for the accumulation tank, the pump will be permanently working. This error message cannot be removed by the STOP button. It is automatically erased after the sensor failure is repaired.

**[E128]** – is displayed, when the flue gas temperature sensor fails. In this case is the boiler control switched to regulate according to the boiler temperature. The error message is erased automatically after the fault of the flue gas temperature sensor is solved.

**[E3]** If several failures occur in one moment, their total is displayed. In such case it is necessary to check the functionality of all sensors.

### 3.12 DISASSEMBLY OF THE REGULATOR

**If it is necessary to disassemble the regulator, do the following:**

- turn the main switch off
- disconnect the boiler from electricity mains
- demount the regulator
- demount the connectors from the regulator

### 3.13 TECHNICAL SPECIFICATION OF THE REGULATOR

|  |                        |
|--|------------------------|
| Power supply                                     | 230V $\pm$ 10%, 50Hz   |
| Input (not including the ventilator and pumps)   | < 4VA                  |
| Range of measuring the boiler temperature        | -9 – 109 °C $\pm$ 1 °C |
| Range of measuring the flue gas temperature      | -30–500 °C $\pm$ 1 °C  |
| Max. input of devices connected to the regulator | 2A/230V                |



**CAUTION:** not to get injured by the electrical current, do not remove the cover of device before disconnecting it from electricity mains!

## 4 TECHNICAL DESCRIPTION OF THE ATTACK DPX LAMBDA

### 4.1 REGULATION OF BURNING

The boiler output is regulated according to the flue gas temperature by the air inlets to the particular oxygen value. The flue gas temperature for burning down is adjusted. If there is a lot of fuel (totally full feeding chamber) and the boiler temperature achieves 90 °C (overheating), the flue gas fan is stopped, flap for primary air is closed and flap for secondary air is open for 25 %. When the boiler temperature decreases to less than 88.5 °C, the flap for secondary air is for 30 seconds open for 100 % (chimney cleaning) and the primary air flap is regulated according to the requirement for the flue gas temperature.

**Automatic boiler stop:** After the fuel burns out, the boiler can be stopped automatically or by setting the flue gas temperature (TAG) or by a setting the value for oxygen (optional function).

**Boiler stop by setting the flue gas temperature:** When the fuel burns out and the flue gas temperature decreases to less than 25 % of the adjusted value, the boiler stops after 15 minutes. This is recommended only when the big or wet wood logs are being used.

**Stop by the oxygen value:** If the boiler works for more than 45 minutes and the oxygen value exceeds 14 % for more than 15 minutes, then the boiler stops. This should be a standard function, when the boiler cooling by chimney is limited. Ignition with remaining coal is easier and there is less smoke by heating up.

When the boiler stops, the flue gas fan is stopped, the primary air flap is closed, the secondary air flap remains open for 25 % until the flue gas temperature decreases below 100 °C.

**Automatic restart after the power shortage:** After the power shortage, the secondary air flap is open for 100% for 30 seconds to let the chimney clean.

**Overheating (boiler temperature above 90 °C):** The secondary air flap remains open for at least 25 %.

**After turning the boiler off (automatically or manually):** The primary air flap V1 is closed (0%), the flue gas temperature is above 100 °C, the secondary air flap remains open for at least 25 % and function of the automatic operation is inactive.

### 4.2 IGNITING AND REFILLING THE FUEL

#### Basic instructions:

Check the pressure (and level of water) in the heating system before igniting.

The fuel has to be prepared in the boiler.

Ignite the fuel (see the prescriptions for boiler operation) and the rest of fuel in the feeding chamber

### 4.3 IGNITING OR REFILLING THE FUEL

If it is possible due to the requirement for heat and the rest of the fuel in the feeding chamber, check the thermometers in the feeding chamber.

**Effect:** Maximum utilization of fuel

**Beginning:** When the boiler is stopped (the indicator light 1 does not flash), make the fire as first.

### 4.4 REFILLING THE FUEL DURING THE BOILER OPERATION

Refill the fuel quickly and close the door immediately.

### 4.5 FUNCTION AND DISPLAYING THE TEXT BY IGNITING OR REFILLING THE FUEL

**After pressing the „+“button it comes to the following procedure:**

- The boiler is started the indicator light 1 flashes and the ignition is running
- The text is displayed:

**DO NOT OPEN!**

**WAIT**

- the flue gas fan and regulation of burning are started
- the supply pump and regulation of the return and supply valve are started
- the generator of an alternative energy is stopped by the switch
- after 5 seconds appears the text:

**FUEL DOOR UNLOCKED**

- and in 10 seconds is the electromagnetic door-lock released (is it is disposable)
- after 10 seconds appears the text:

**CAUTION!**

**OPEN SLOWLY!**

- after 5 seconds appears the text:

**IGNITION**

- Prepare and ignite the fuel following the instructions on the page 11, close the feeding door partly. If the bar chart is full, the fuel is ignited, close the door.
- If the bar chart is full and ignition or process of fuel loading takes more than 15 minutes, it is switched to the operating display mode.
- The regulator stops the boiler after 15 minutes, if:
- There was no ignition and the regulator started the burning process despite of that fact, because it was accidentally started by the „+“button.
- The fire extinguished after closing the door, because there was lack of wood splinters or the fuel is too wet.

## 4.6 DISPLAY OF THE OPERATING MODE BY THE BOILER STARTED

- Text on display:  
**BOILER TEMPERATURE**  
°C
- After 5 seconds appears the next text:  
**FLUE GAS TEMPERATURE**  
°C
- This text appears on display every 5 seconds.

## 4.7 EXCESSIVE FLUE GAS TEMPERATURE

If the flue gas temperature exceeds 300 °C because the feeding door, the door for ignition or the ashtray door was open for too long time, then appears the text **excessive flue gas temperature**– (see display)

In this case: **CLOSE THE DOOR IMMEDIATELY!**

If the flue gas temperature exceeds 350 °C, the flue gas fan is stopped from safety reasons and after the temperature achieves 299 °C or less, the flue gas fan is started again. Thereby is the flue gas fan and the flue gas sensor protected against damage.

## 4.8 BOILER OVERHEATING

When the feeding chamber is totally loaded with too much of fuel, the boiler temperature rises to 90 °C and more. Then it comes to the state of overheating and the flue gas fan is automatically stopped. Display flickers with the text:

**Overheating**  
**DO NOT OPEN**

The boiler door must not be opened. By overheating it comes to the high fuel consumption and ecological damages.

## 4.9 DISPLAY OF THE OPERATING MODE WHEN THE BOILER IS OUT OF ORDER

When there is no more fuel left, the boiler is automatically stopped by regulator or it can be stopped manually by the „+“button (this serves only for safety stop, e.g. when there is no water in the boiler). After the boiler is stopped, the following text is displayed immediately:

**BOILER TEMPERATURE**  
°C

The display illumination is turned off after 15 minutes.

## 4.10 FUNCTIONS OF THE AUTOMATIC PROTECTION

If the boiler did not heat for 7 days, the flue gas fan is started for 2 minutes and the boiler is „blown through“ by the fresh air to get dried. The reverse and supply valve are working as well and the supply pump is started for 10 seconds. The following text is displayed during this procedure:

**PROTECTION FUNCTION**  
**PLEASE WAIT**

After completing the protection function is the display automatically switched to the operating mode.

## 4.11 INFORMATION ABOUT THE CURRENT OPERATION

The „←“ button enables to enter into the menu „Options“. The first option – „Information“ – is displayed immediately. By the „←“ button it is possible to enter into the „Information“ menu and to browse there by the „+“ and „-“ buttons.

The „←“ button is used to exit from menu and then is the display automatically switched to the operating mode. If no button is pressed for 30 minutes, the display automatically is switched to the operating mode automatically.

If any fault occurs or the temperature rises extremely, the options menu closes automatically.

## 4.12 INFORMATION DISPLAYED:

| Menu           | Submenu                                | Indication |  |
|----------------|--|------------|--|
| Information    | Boiler set<br>°C                       | --         | Indicates the adjusted temperature value in the boiler   |
|                | Boiler temperature<br>°C               | ---.-      | Current value. Indicates the current boiler temperature.   |
|                | Flue gas set<br>°C                     | ---.-      | Indicates the adjusted flue gas temperature  |
|                | Flue gas temperature<br>°C             | ---.-      | Indicates the current flue gas temperature   |
|                | O <sub>2</sub> set<br>%                | --.-       | Indicates the adjusted oxygen value in the flue gas.   |
|                | O <sub>2</sub><br>%                    | --.-       | Indicates the current oxygen value in the flue gas.  |
|                | CO <sub>2</sub> set<br>%               | --.-       | Indicates the adjusted value of the CO <sub>2</sub> in the flue gas  |
|                | CO <sub>2</sub><br>%                   | --.-       | Indicates the current value of the CO <sub>2</sub><br>Note: The fix value of the CO <sub>2</sub> for calculation is max. 20,3 %. |
|                | Suction fan                            | ON/OFF     | Operating state of the fan   |
|                | Circuit pump                           | ON/OFF     | Operating state of the pump  |
|                | Primary motor<br>%                     | --.-       | Position of the primary air flap   |
|                | Secondary motor<br>%                   | --.-       | Position of the secondary air flap   |
|                | Lambda                                 | --.-       | Ratio of air (current value) Note: The fix value of the CO <sub>2</sub> for calculation is max. 20,3 %.                          |
|                | Efficiency<br>ETA – F (%)              | --.-       | Grade of efficiency of burning – current value<br>Temperature of air for burning (35 °C) is used for calculation                 |
|                | Total temperature excess (%)           | --.-       | Total ratio of the temperature excess (%) during the total time of burning (total of the operating hours)                        |
|                | Temperature excess–<br>10 loadings (%) | --.-       | Ratio of the excessive temperature in (%) by the last 10 loadings.   |
|                | Operating hours<br>H                   | --.-       | Operating hours of the boiler. After 60 000 hours is the counter deleted.  |
|                | Software                               | --.-       | Program version nr.  |
|                | Serial number                          | -----      | Serial or production number of the regulator.  |
| Test of device |  |            |  |
| Safety test    |  |            |  |
| Setting        |  |            |  |
| END            |  |            |  |

## 4.13 SETTING FOR COMMISSION OF THE ATTACK DPX LAMBDA

The device can be commissioned, when the minimum requirements for the testing operation or heating are fulfilled (see the chapter 1.2). Then it is necessary to make the following settings.

### Settings by using the code of the service technician

The button „←“ enables to enter into the menu of Options, where the submenu „settings“ can be changed by the „+“ and „-“. The button „←“ is used to confirm the selection.

Exit from the submenu comes automatically after selecting the „supply valve“ by the button „←“. Then is the display automatically switched into the operating mode. If no button is pressed during 1 minute, the display is automatically switched to the operating mode.

### Settings:

| Menu                 | Submenu   | Indication   |
|----------------------|---|--|
| Information          |   |  |
| Test of device       |   |  |
| Safety test          |   |  |
| <b>Setting</b>       | Entering the code<br>---  | Set the code by the „+“ button. The random number is displayed on the left side. Enter the code and confirm by the button „←“. The code for service technician is available by producer. |
|                      | 01:Language<br>German DE<br>English GB<br>Spanish ES<br>Italian IT<br>French FR<br>Swedish SE<br>Polish PL<br>Slovak SK<br>Czech CZ<br>Dutch NL<br>Danish DK<br>Hungarian HU<br>Slovenian SI                                    | Function: Setting the national language  |
|                      | 02: Boiler setting<br>°C 85   | Function: Set the temperature in the boiler<br>Producer: 85 °C<br>Range for setting: 75 – 85 °C  |
|                      | 03: TAG setting<br>°C 180   | Function: Setting the flue gas temperature (nominal boiler output 180 °C).<br>Producer: 180 °C<br>Range for setting: 110 – 240 °C<br>Note: TAG = flue gas temperature                    |
|                      | 04: O <sub>2</sub> setting<br>% 6,0   | Function: Setting the O <sub>2</sub> value for burning 6 %<br>Producer: 6,0 %<br>Range for setting: 4,0 – 8,0 %  |
| 05: TADstart<br>K 60 | Function: To get the sufficient output of heating before closing the feeding door<br>Producer: 60K<br>Range for setting: 25K d – 125K<br>Note: TAD= temperature difference. Difference between the flue gas temperature and the |  |

|     |  |  |
|-----|--|--|
|     |  | temperature in the boiler.   |
|     | 06 : Disconnection<br>O <sub>2</sub><br>TAG              | Function: The boiler for wood burning turn off after burning out due to<br><b>O<sub>2</sub></b> – indicates higher amount of the rest coal (easier start)<br><b>TAG</b> – indicates the minimum rest coal (recommended by problems with burning – shapeless or wet fuel)<br>Producer: O <sub>2</sub><br>Setting: O <sub>2</sub> /TAG |
|     | 10 : V1 primary air<br>Air (%)                      85   | Function: When there is a flue gas sensor or oxygen fault, it is regulated to the adjusted value. This is a temporary solution until the fault is removed – <i>it is not a normal operating function!</i><br>Producer: 85 %<br>Range for setting: 0 % – 100 %  |
|     | 11 : V2 secondary air<br>Air (%)                      40 | Function: When there is a flue gas sensor or oxygen fault, it is regulated to the adjusted value. This is a temporary solution until the fault is removed – <i>it is not a normal operating function!</i><br>Producer: 40 %C<br>Range for setting: 0 % – 100 %   |
| END |  |  |

After the settings are done, the test of device is performed, its correct functionality is checked and the safety test is made.

## 4.14 CANCELLATION OF THE PRODUCER'S FUNCTION

For this procedure you need the code from producer. It is possible to set the operating hours of the boiler, number of overheating states and the last 10 burnings to 0.

Enter and exit from the appropriate submenu is the same as it is given in the chapter 8.1. If no button is pressed within 1 minute, the regulator automatically switches to the operating mode.

| Option         | Submenu                        | Indication   |
|----------------|--------------------------------|--|
| Information    |                                |  |
| Test of device |                                |  |
| Safety test    |                                |  |
| <b>Setting</b> | Code<br>---                    | Enter the code from producer by the „+“ button. The random number is displayed on the right side. Change it to the code from producer and confirm by the button „←“. The next setting is displayed.  |
|                | Cancel<br>NO/YES               | Select „YES“ by the „+“ button. After pressing the „←“ button is the explanation of the setting displayed and the menu is closed.<br>By selecting „YES“ you can set the boiler operating hours and the total excessive temperature, the last 10 burnings are set to 0. |
|                | 33: Output reduction<br>NO/YES | Select „YES“ by the „+“ button. After pressing the „←“ button is the explanation of the setting displayed and the menu is closed.<br>By selecting „YES“, the boiler output is reduced by 20 % is the boiler temperature exceeds the adjusted temperature for 2K.       |
| End            |                                |  |

### Testing

The test of device and safety test have to be done by the presence of the technician!

#### Test of device

The test of device can be done only when the boiler is turned off!

The test can be done, only when there is no danger of overheating!

The test is selected and done by the menu button „←“ (enter into the menu of Options). In the next menu there is a „test of device“ found by the „←“ button and the confirmed by the button „←“. The appropriate step of the test is activated by the „+“ button and deactivated by the „-“ button. The next step is selected by the „←“ button.

The test of device is completed after the last point of the test by the „←“ button and the display is automatically switched to the operating mode. The test can be interrupted by pressing the buttons „+“ and „-“ at once.

If no button is pressed within 15 minutes, the display is automatically switched to the operating mode.



| Option                | Submenu   | Indication  |
|-----------------------|---|---|
| Information           |   |   |
| <b>Test of device</b> | O <sub>2</sub> scales<br>End of the test (+, -) | After pressing the „+“ button is the text „calibrate“ displayed<br>The calibration takes approx.600 seconds.<br>Automatic calibration is done only in the case that the boiler did not burn for 48 hours and the operating time of the sensor is higher than 200 hours. By the manual setting there must be no fire in the boiler, nor the glowing rest of the fuel! If it is not necessary to adjust the scale, press „←“ and the next step is displayed.<br>Note: For quick exit from menu press „+“ and „-“ at once. |
|                       | Flue gas fan<br>End of the test(+,-)            | By pressing + start the flue gas fan<br>By pressing - stop the flue gas fan<br>By pressing ← select the next point of the test  |
|                       | Circuit pump<br>End of the test(+,-)            | By pressing + start the circuit pump<br>By pressing - stop the circuit pump<br>By pressing ← select the next point of the test  |
|                       | Primary motor<br>End of the test(+,-)           | By pressing + open the primary air flap<br>By pressing - close the primary air flap<br>By pressing ← select the next point of the test  |
|                       | Secondary motor<br>End of the test (+,-)        | By pressing + open the secondary air flap<br>By pressing - close the secondary air flap<br>By pressing ← select the next point of the test  |
|                       | Illumination<br>End of the test (+,-)           | By pressing + turn the text display illumination on<br>By pressing - turn the text display illumination off<br>By pressing ← select the next point of the test  |
|                       | Indicator light 1<br>End of the test(+,-)       | By pressing + turn the indicator light 1 on<br>By pressing - turn the indicator light1 off<br>By pressing ← select the next point of the test   |
|                       | Indicator light 2<br>End of the test (+,-)      | By pressing + turn the indicator light2 on<br>By pressing - turn the indicator light2 off<br>By pressing ← select the next point of the test  |
|                       | Indicator light 3<br>End of the test (+,-)      | By pressing + turn the indicator light3 on<br>By pressing - turn the indicator light3 off<br>By pressing ← select the next point of the test  |
| Safety test           |   |   |
| Setting               |   |   |
| END                   |   |   |

## 4.15 SAFETY TEST

The safety test can be done only in the case that the boiler is started and working for at least 1 hour to make its output adequate to the normal operation.

The test is selected and performed by the „←“ button (enter into the Options menu). Select the test by the „-“ button and confirm by the „←“ button. The safety test is started automatically. During the test it is possible to hold the „+“ button for 30 seconds not to let the test process automatically terminated (see the explanation in the table below).

There is the time limit of 30 minutes for the test. It is automatically stopped or interrupted, if:

1. the boiler temperature increases above 110 °C
2. the „+“ button has not been pressed within 30 seconds.

Then the regulator automatically switches to the operating display mode.

| Menu               | Submenu                                      | Indication                            |
|--------------------|--|---------------------------------------|
| Information        |  |                                       |
| Test of device     |  |                                       |
| <b>Safety test</b> |  | Time limit of 30 minutes for the test |
|                    | Safety test (sec)<br>Boiler temperature (°C) | + 30<br>--,-                          |
| Setting            |  |                                       |
| END                |  |                                       |

## 4.16 MAINTENANCE OF THE HEATING SYSTEM AND THE BOILER

It is necessary to check, eventually to refill the water in the heating system at least 1x in 14 days. If the boiler is out of order during the winter period and the water could freeze in the heating system, then the water should be replaced with an antifreeze mixture approved by the producer or it should be discharged out of the system. Normally should be the water discharged only in urgent cases and for as short time as possible. At the end of the heating season it is necessary to clean the boiler properly and to replace the damaged parts. Twice a year it is necessary to dismantle the fan, to clean the radial impeller and to clean the fan air chamber.

### **Exchange of the sealing cord of the door**

Undo the worn sealing cord by the screw driver and clean the groove, where it was laid. Take the new sealing cord and put its ends into the horizontal parts of the groove. Use your hand, eventually a hammer to press the cord into the groove around the door.

### **Adjusting the hinges**

After a particular period is the sealing cord in the door pressed. To ensure its tightness is necessary to change the position of the door by screwing the door hinges. The feeding door and the bottom door are fixed to the boiler body by two hinges that are connected to the door by a long joint. To adjust the hinges, it is necessary to remove the joint and to turn and to screw the joint. Fix the door and put the joint into the hinge.

### **Replacement of the nozzle**

The nozzle is laid in the boiler body on the holder. In the bottom part is the nozzle sealed by a boiler sealant and in the upper part there is a sealing cord around. When replacing the nozzle, remove the sealing cord from the groove by a screw driver. Take the nozzle out and clean the holder properly from tar and old sealant. Then treat the bottom part of the nozzle with the fireproof sealant and put the nozzle on the clean holder with the arrow towards the rear boiler part. There should be the same space on the both sides of the nozzle. Take the new set of the sealing cords for the nozzle and press it lightly into the gap just around the nozzle.

### **Adjustment of burning in the boiler**

The burning is adjusted by the primary and secondary regulation flap. Producer sets the boilers to the optimum conditions of burning with reference to the emissions and flue gas temperature. Only the service staff trained by producer can make the adjustment.

### **Warning**

It is not possible to use the warranty service to set the boiler combustion, to correctly set the door, to replace the door seal and to replace the worn nozzle because of dependence on the installation conditions, the wear and tear of the product, the product connection on the chimney, and the type and quality of the fuel used!

### Optimum setting of the regulation flaps:

Primary / secondary air flap in [%]:

**DPX15** – 50/40

**DPX20** - 50/40

**DPX25** – 50/40

**DPX30** – 50/40

**DPX35** – 80/40

**DPX40** – 100/40

**DPX45** – 100/40

**DPX80** – 20/55

**DPX100** – 18/75

### Operation with permanent burning

It is possible to keep the permanent burning, i.e. the fire in the boiler for the whole night without need to heat up during the day, but only in the winter period. For the operation with permanent burning it is necessary to prepare the boiler in the following way:

- Lay some bigger wood logs (4 – 6 pcs.) on a glowing layer of fuel
- Close the mixing valve partly – temperature of water in the boiler achieves 80 – 90 °C
- The regulation flap controlled by thermal regulator is automatically closed and the fan is stopped.

After the boiler is prepared in this way, the burning is kept for more than 12 hours. When the boiler is in the operation of permanent burning, the water temperature must be 80 – 90 °C.

## 4.17 BOILER CLEANING

**The boiler has to be cleaned regularly and properly every 3-5 days, otherwise there is a risk of its wrong functionality, shortened service life or damage, shorten the out put of the boiler and isolates the heat exchange surface.**

With more ash there is insufficient space for fuel burning and the ceramic nozzle holder and thus the entire boiler may be damaged. Clean the boiler by first switching on the fan, open the filling door and mow the ash with the slit into the bottom. Fold the long pieces of fuel in the feeding hopper. Throw several times the lever on the left side of the boiler. Fly ash and carbon black after opening the bottom cleaner. Open the lower door to clean the bottom of the dirt. The cleaning interval is dependent on wood quality (humidity) and heating intensity, chimney draft and other circumstances. We recommend cleaning the boiler once a week. Do not remove the fireclay. Clean the fan impeller at least once a year and check with the cleaning holes for the primary and secondary air ducts that flow into the attachment chamber, or clean them by scraping openings and blowing compressed air. It affects the performance and quality of combustion.



**ATTENTION**–Regular and proper cleaning is important to ensure the permanent output and service life of the boiler. The warranty is not valid if the boiler is not sufficiently cleaned and damaged.

## 4.18 PRESCRIBED FUEL

The prescribed fuel is dry chopped and log wood with diameter of 80 – 150 mm, moisture of 12 % (min.) – 20 % (max.) and heat value 15 – 17 MJ/kg<sup>1</sup>. It is also possible to burn big pieces of the wooden waste together with rough wood logs.

### Note

The wood logs of higher diameter must be chopped to halves or to quarters (due to the requirement for the boiler operation at nominal output). It is possible to burn soft or hard wood. The wood must be dry!

The boiler output depends on the wood moisture. The boiler output and function are ensured by the max. wood moisture of 20 %. The warranty is not valid if the boiler is operated with the fuel of higher moisture than 20 %.

### Energy content of the most used wood types

| Wood   | Heat capacity per 1 kg |       |     |
|--------|------------------------|-------|-----|
|        | kcal                   | MJ    | kWh |
| Spruce | 3 900                  | 16,25 | 4,5 |
| Pine   | 3 800                  | 15,80 | 4,4 |
| Birch  | 3 750                  | 15,50 | 4,3 |
| Oak    | 3 600                  | 15,10 | 4,2 |
| Beech  | 3 450                  | 14,40 | 4,0 |

## 4.19 ASSEMBLY AND INSTALLATION OF THE BOILER

### Boiler installation

Only a person with valid authorization for installation and assembly of the heat technology devices can install the boiler. The installation requires an appropriate project that is in line with the valid prescriptions and this instruction manual. Before installing the boiler must the technician check, if the data given on the production label are in conformity with the data in the project and the documentation attached to the boiler. The boiler must be connected in line with the valid prescriptions, regulations and this instruction manual.

**The producer takes no responsibility for damages caused by wrong connection or operation.**

### Placing the boiler

The boiler is intended to be installed and operated in the premises with the basic environment (AA5/AB5) following the STN 33 2009-04. By the boiler installation it is necessary to keep the safety distance of its surface from flammable materials according to their degree of flammability:

- from materials of the flammability degree B, C1 and C2 200 mm
- from materials of the flammability degree C3 400 mm
- from materials of the flammability degree not approved

### Examples of classification of the building materials by their degree of flammability:

- degree of flammability A inflammable (bricks, blocks, ceramic tiles, mortar, parging)
- degree of flammability B partly flammable (heraklith, lignos, board from basalt felt, novodur)
- degree of flammability C1 difficult to ignite (hardwood (oak, beech), plywood, werzalit, hardened paper)

- degree of flammability C2 normal combustibility (softwood (pine, spruce), chipboard, solodur)
- degree of flammability C3 easily ignited (wood fibre boards, polyurethane, PVC, foam rubber, polystyrene)

The sealing board or protection covering (on the protected item) must exceed the boiler edge for at least 300 mm. Also other items from flammable materials must be protected in this way, if they are placed near the boiler and it is not possible to keep the safe distance.

If the boiler stands on a flammable surface, it must be protected by an inflammable, heat insulating mat, which exceeds the edge on the side of the feeding door and the ash tray door for at least 100 mm. All materials of the A flammability degree can be used as an inflammable, heat insulating mat.

The boiler must be placed in a such way ensuring sufficient space of at least 1 m from the front and 0,5 m from the left (right) and rear side. It is necessary to leave the space of at least 1 m above the boiler.

This space is necessary for basic operation, maintenance and eventual service of the boiler. It is not allowed to place the boiler in dwelling premises (including corridors). There must be an opening for the air inlet for burning of at least 200 cm<sup>2</sup> depending on the boiler output.



**CAUTION!** The items from flammable materials must not be laid on the boiler and in the distance shorter than the permitted (safe) one. The boiler must be turned off, if there is a danger of fire or explosion due to the work (e.g. work with painting materials, glues, etc.).

### **Air inlet**

For correct operation of the boiler it is necessary to ensure sufficient air supply for burning. There must be an opening for the air inlet for burning of at least 200 cm<sup>2</sup> depending on the boiler output.

### **Boiler connection to the heating system**

Only a trained technician can install and service the ATTACK DPX boiler. Before installing the boiler, it is necessary to flush (to clean) the whole heating system. The system can be filled only the water treated to the values under the STN 07 7401: 1992. Callosity of the water must not excess 1mmol/l and concentration of the Ca<sup>2+</sup> must be lower than 0,3 mmol/l.

**If these conditions are not kept, the warranty is not valid!**

### **Chimney**

Connection of the appliance to the chimney hole must be always done with permission of the appropriate chimney sweep association. The chimney must generate sufficient draught and take the flue gas out into the atmosphere under the all operating conditions.

Correct dimensions of the chimney hole are important the correct boiler function, because the burning, output and boiler life-time are influenced by the draught. The chimney draught directly depends on its diameter, height and roughness of the internal wall. It is not allowed to connect any other appliance to the chimney, where the boiler is connected. Diameter of the chimney must not be smaller than the connection part on the boiler. The chimney draught must achieve the prescribed values, but it cannot be too high, not to decrease the boiler output and interrupt the burning (flame). If there is too strong draught, install the throttle flap into the chimney hole between the boiler and the chimney.

**Prescribed dimensions of the chimney section 15-45:**

|          |                  |
|----------|------------------|
| 20×20 cm | min. height 7 m  |
| Ø 20 cm  | min. height 8 m  |
| 15×15cm  | min. height 11 m |
| Ø 16 cm  | min. height 12 m |

**The prescribed values of the chimney cross section dimensions for boiler 80, 100:**

|          |                 |
|----------|-----------------|
| Ø 25 cm  | min. height 9 m |
| Ø 30 cm  | min. height 7 m |
| 25×25 cm | min. height 8 m |

The exact chimney dimension is defined by the STN 73 42 10. The prescribed chimney draught is given in the Technical parameters.

**Flue gas connection**

The flue connection must lead into the chimney hole. If it is not possible to connect the boiler to the chimney hole directly, then the appropriate extension should be as short as possible, of up to 1 m length, without any additional heating area and it should ascend in direction to the chimney. The flue connection must be mechanically tight (it should be mounted to the boiler and tightly fixed by screws) and tight against the flue leakage. The flue connections must to lead through the foreign dwelling or commercial premises. The internal diameter of the flue connection must not taper in direction to the chimney. It is not suitable to use the elbow connectors.

**Boiler connection to the electricity mains**

The boiler is connected to the electricity mains of 230V/ 50Hz by an electrical cord with plug. In the case of need, the power supply cord of the M type must be replaced with an adequate one by the service organization. The appliance must be placed in the way enabling to reach the connection plug. The boiler must be connected to the 16A socket circuit by a circuit breaker (following the STN EN 60 335-1 + A11:1997).

**Choice and connection of the control and regulation components**

The boiler is delivered with the basic regulation and control equipment. Connection of these items is given on the scheme of connection. We recommend extending the boiler regulation for the next regulation components for more comfortable and economical operation. Each pump in the system must be controlled by an individual thermostat not to let the temperature of the heating water decrease under 65 °C.

The electrical installation related to the additional boiler equipment has to be done by a specialist and following the valid regulations.

Connection of the next components is solved by a project architect according to the specific conditions of the heating system. The electrical installation related to the additional boiler equipment has to be done by a specialist and following the valid regulations.



**Warning: the heating system must be equipped with a safety valve against overpressure.**

## 4.20 BOILER PROTECTION AGAINST CORROSION

Use of the mixing device (Regumat Attack – Oventrop) is a suitable solution of the problem with corrosion. It enables creation of the separate boiler and heating circuit. Thereby is the boiler protected against undercooling below 65 °C and the creation of water steams, acids and tars in the boiler's feeding chamber is eliminated.

The Regumat Attack – Oventrop device keeps the constant temperature of the return heating water flowing into the boiler over 65 °C by setting the thermostatic head to the level 5–6. When the individual thermal regulation mixing valve is used, it is possible to control the temperature of the heating water independently on the temperature of water in the boiler by setting the flap. The temperature in the boiler has to be kept in the range of 80 – 90 °C.

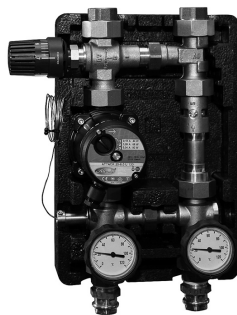

| Technical parameters REGUMAT ATTACK-OVENTROP |        |        |
|--|--------|--------|
| Calibre                                      | DN 25  | DN 32  |
| Maximum pressure                             | 10 bar | 10 bar |
| Maximum temperature                          | 120 °C | 120 °C |
| Value of kvs                                 | 3,9    | 5,3    |
| Construction height of insulation            | 365 mm | 472 mm |
| Width of insulation                          | 250 mm | 250 mm |
| Axial distance                               | 125 mm | 125 mm |

The Regumat consists of three-way mixing valve, circulating pump, closing valve, thermometers and insulation. This solution is advantageous, because it is compact, enables simple operation and ensures protection of the steel boiler's heat exchanger.

### Regumat for the boiler:

ATTACK DP 25 – 35, ATTACK DPX 15 – 35,  
ATTACK SLX 20 – 35, ATTACK PELLET 30 Plus,  
ATTACK WOOD & PELLET 25: **typ DN25**

(there is also an option to order the version with low-energetic pump)

### Ordering code:

**DPP25003**

ATTACK DP 45 – 95, ATTACK DPX 40 – 100,  
ATTACK SLX 40 – 55: **type DN32**

**DPP25006**



## 4.21 BINDING NORMS FOR PROJECTING AND INSTALLATION OF THE BOILERS

|                         |  |
|-------------------------|--|
| STN EN 303-5            | Heating boilers for solid fuels  |
| STN 73 42 10            | Construction of the chimneys and flue connections  |
| STN EN 60 335.1 +A11    | Fire safety of the local appliances and heat sources   |
| STN 06 03 10            | Central heating, projecting and installation   |
| STN 06 08 30            | Safety devices for central heating and D.H.W. preparation  |
| STN 07 74 01            | Water and steam for thermal energetic devices with operation pressure of steam up to 8 MPa   |
| STN 332000 4-46         | Electrical installations of buildings – part 4: Ensuring safety  |
| STN 33 2000-1: 2009-04  | Electrical installations of buildings – part 3: Definition of the basic characteristics  |
| STN EN ISO 11202:2009   | Measuring the emissions levels of the acoustic pressure at a workplace and other precisely defined places.   |
| STN EN ISO 12100-2:2004 | Safety of machines. General principles of construction of machines, Part 2: Technical principles.  |
| STN EN ISO 14120: 2016  | Safety of machines– protection covers.   |
| ČSN ISO 7574-2          | Acoustics. Statistical methods for definition and verification of the determined values. Noise emission of machines and devices. Part 2: Methods for particular of machines. |
| ČSN ISO 1819:1993       | Devices for fluent cargo transport. Safety prescriptions.  |
| STN EN ISO 15614-1      | Requirements for quality of the fusion welding of metal materials  |
| STN EN 287-1            | Welding of reserved technical devices  |
| STN 07 0240             | Low pressure boilers, technical prescriptions  |
| STN 07 0245             | Warm water boiler with the output up to 50 kW. Technical requirements, testing   |
| STN 07 7401             | Water and steam for heat energy devices with the steam operating over pressure up to 8 MPa.  |
| STN 73 4210             | Manufacturing the chimneys and flue ways and connection of devices   |

## 4.22 INSTALLATION AND REPLACEMENT OF THE FIREPROOF PARTS

Insert the rear part of the ash tray pos. 1 into the bottom chamber with cut part rearwards. It is necessary to insert it horizontally and to turn it afterwards. Place the front left pos. 2 into the lower chamber, this part needs to be placed horizontally and then turned. Insert the front part of the ashtray pos. 3 in the same way. Press the both parts together and shift them tightly to the rear part of the ash tray.

### *Boiler section- burning chamber*

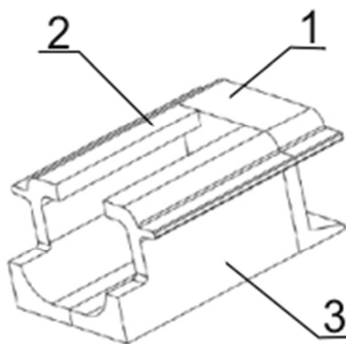
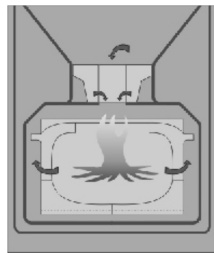
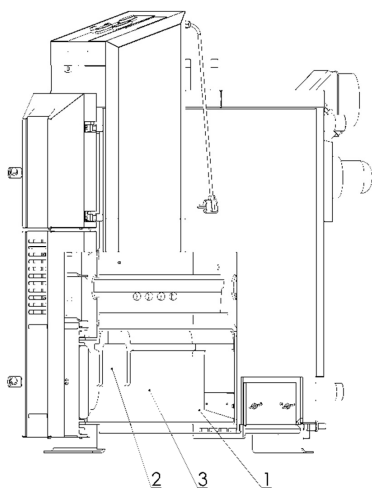

## 4.23 INSTALLATION AND REPLACEMENT OF THE FIREPROOF PARTS DPX80

The rear of the ashtray pos. 1 insert the bottom part into the bottom chamber with the selected part back. Place it in the middle of the chamber and push it against the rear plate. Insert pos. 2 - 2x and push them to the rear. Then paste pos. 3 - 2x and push them to the previous parts. Insert the pos. 4 + pos. 5. Push them to the previous parts. For the correct operation of the boiler it is necessary that all parts of the ashtray are pushed together. Then insert the nozzle into the upper chamber pos. 6, then insert the cubes pos. 7 and pos. 8. To the lower layers (approx. 5 mm) of stove-builder sealant must be applied to the bottom surfaces of these parts. Push the glass fiber braided cord into the nozzle and coultter recesses.

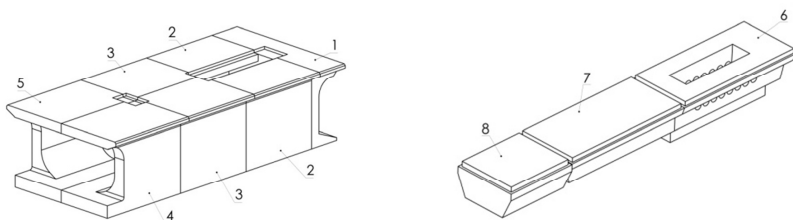

## 4.24 BOILER CONNECTION

*The boiler must be permanently operated by nominal output. If the boiler works at the output that is lower than the nominal output, then for the case of the heat outtake it is necessary to connect it to the accumulation tank with the volume of at least 460 l STN EN 303-5, article 4.2.5).*

### Connection with the accumulation tanks

Connection system is based on principle of heating up of water in accumulation tanks, where the warmth is gradually taken away from the tanks according to the request from the heating system. By the operation with several heating ups at full performance, accumulation tanks will be heated for the temperature of 90 – 100 °C. Heating with accumulation tanks in connection with the ATTACK DPX boiler brings more advantages. To the main advantages belongs longer boiler life-time and also lower consumption of fuel.

### Recommended volumes of accumulation tanks according to boiler output are following:

|        |      |        |
|--------|------|--------|
| DPX15  | 800  | 1000 l |
| DPX25  | 1500 | 2000 l |
| DPX35  | 2000 | 2500 l |
| DPX45  | 500  | 3000 l |
| DPX80  | 2000 | 5000 l |
| DPX100 | 2500 | 5000 l |

## 4.25 OPERATION WITH ACCUMULATION TANKS

When the boiler is heated up and working at the full output, it warms the water in the accumulation tank to the average temperature of 80 °C, after 1 – 3 loadings. After the fuel burns out, the heat is taken from the accumulation tank from the three-way valve. The time of outtake depends on the size of the tank and on the external temperature. During the heating season it can take 1 – 3 days (if the min. prescribed volume is kept). If it is not possible to use the accumulation tank of the prescribed volume, then we recommend using at least one tank with the volume of 500l to let the boiler run and to after run. **The minimum volume of the accumulation tanks is given in the table of technical parameters.**

### The accumulation tanks available:

| Type of the tank | Volume (l) | Diameter (mm) | Height (mm) | Heat exchanger area (m <sup>2</sup> ) |
|------------------|------------|---------------|-------------|---------------------------------------|
| AK500            | 500        | 650           | 1 650       |                                       |
| AK800            | 800        | 790           | 1 730       |                                       |
| AK1000           | 1 000      | 790           | 2 050       |                                       |
| AS500            | 500        | 650           | 1 650       | 2,0                                   |
| AS800            | 800        | 790           | 1 730       | 2,4                                   |
| AS1000           | 1 000      | 790           | 2 050       | 2,8                                   |

### Insulation of the tanks

The accumulation tanks ATTACK AK500, AK800, AK1000, AS500, AS800 and AS1000 are delivered with the detachable insulation from soft polyurethane with the white leatherette surface.

### Advantages

The installation of the boiler with accumulation tank brings several advantages:

- lower fuel consumption (even for 30 %). The boiler runs at full output until the fuel burns out by keeping the optimum efficiency.
- longer service life of the chimney and the boiler, minimum creation of acids and condensate
- option of combination with other types of heating (solar collectors, etc.)
- combination of the boiler with floor heating
- comfortable and ecological heating

## 4.26 BOILER PROTECTION AGAINST OVERHEATING

**CAUTION:** Following the norm EN 303-5, the after cooling circuit against the boiler overheating must not be used for other purposes than boiler protection against overheating.



**The valve at the cold water inlet into the cooling loop must be permanently open and the cooling loop of the boiler must be connected to the functional cold water distribution (e.g. to the cold water supply into the water distribution**

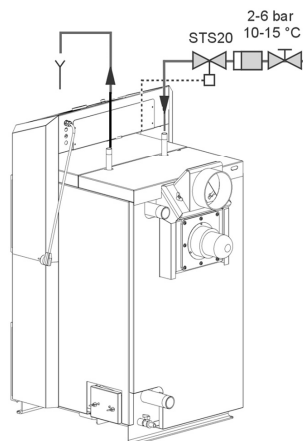

**network) with the temperature of 10 – 15 °C and the operating overpressure of 2 – 6 bar.**

The STS20 valve at outlet of the cooling loop with the sensor placed in the rear part of the boiler protects the boiler in the following way. When the temperature of water in the boiler exceeds 95 °C, then the water from the distribution network flows into the cooling loop to absorb the surplus heat. In the case of boiler overheating and opening the STS20 valve it is necessary to ensure the permanent outtake of the warmed water from the boiler after cooling circuit into the drain.



***If the outtake of cooling water through the cooling loop is not ensured after opening the STS20 valve, there is a danger of boiler damage! In this case is the warranty for the boiler not valid!***

## **4.27 TRANSPORT, HANDLING AND STORING**

In production is the boiler laid on a pallet and fixed by technological screws. It is packed in a paper box, tied up by a tape and wrapped in stretch foil.

Transport, handling and storing of the packed product is allowed only on this pallet.

There are the hanging eyes placed under the upper cover to enable handling with a crane.

Only an approved person can ensure handling with this product.

## **4.28 INSTRUCTIONS FOR PRODUCT DISPOSAL AFTER TERMINATION OF ITS SERVICE LIFE**

Ensure the disposal of the appliance (boiler) by the waste disposal service, eventually use the regulated waste dump, controlled by the municipal authority.

## **4.29 DISPOSAL OF THE PACKAGING**

Dispose the packaging by the waste disposal service, eventually use the regulated waste dump.

## **4.30 ACCESSORIES**

The ATTACK DPX boiler is delivered functionally tested, packed and placed on a wooden pallet. It is delivered with the instruction manual.

**The following accessories are included in the delivery:**

- Instruction manual
- Warranty certificate
- List of contractual service organizations

## 4.31 POSSIBLE ERRORS AND SOLUTIONS

| <b>Error</b>   | <b>Cause</b>  | <b>Solution</b>                                       |
|--|---|---|
| The indicator light „mains“ does not shine                                 | No voltage in the mains   | Check   |
|  | Plug is not properly connected to the socket                                | Check   |
|  | Faulty mains switch   | Replace   |
|  | Damaged current inlet conductor   | Replace   |
| The boiler does not achieve the required parameters                        | Lack of water in the system   | Refill  |
|  | Too high pump output  | Set the flow and switching                            |
|  | Boiler output is not adequate to the heating system                         | Matter of the project                                 |
|  | Fuel of low quality   | Burn dry and chopped wood                             |
|  | Heat up flap is not tight   | Fix   |
|  | Low chimney draught   | New chimney, suitable connection                      |
|  | High chimney draught  | Install the restriction flap into the flue connection |
|  | Long heating up or operation with the heat up flap open                     | Close the heat up flap                                |
|  | Deformation of the fan blades   | Replace   |
|  | Insufficiently cleaned boiler   | Clean   |
| Door are not tight   | Clogged air inlet into the combustion chamber                               | Clean   |
|  | Damaged glass fibre cord  | Replace, adjust the door hinges                       |
|  | Nozzle is being clogged   | Do not burn small wood pieces andrind                 |
| Fan does not rotate or it is noisy   | Low chimney draught   | Wrong chimney   |
|  | If the non-returnable thermostat is used, it is disconnected by overheating | Press the button of the thermostat                    |
|  | Clogged radial impeller   | Clean the fan   |
|  | Faulty capacitor  | Replace   |
|  | Faulty motor  | Replace   |
| Faulty contact in the socket of the current inlet conductor from the motor | Check   |   |

## 4.32 FAULTS AND ERRORS WITH THE SYSTEM ATTACK DPX LAMBDA

**It is not possible to heat in the boiler in case of the following errors and warnings:**

- the red display 3 shines (errors), operation in the wood boiler is not possible
- the red display 3 flickers (warning), correct boiler operation is not possible. The text automatically disappears after the cause of error is solved.

**The boiler operation under the emergency mode is possible, if:**

- the yellow display 2 (warning) lights

All the emergency programmes in the options of the regulator are automatically explained and they serve for a short-term operation of heating. Thereby:

- It is recommended to remove the error immediately!
- If the operation under an appropriate emergency program takes too long, it may come to the damage of the chimney and the boiler and to the consequent loss of the guarantee.

### Start of the emergency thermostat (error)

|   |  |
|---|--|
| <p>STB is started<br/>reset<br/>Temperature in the<br/>boiler ( °C)</p> | <p><b>Cause:</b> The temperature in the boiler is &gt;95 °C because of too big amount of fuel, power shortage, error by heat outtake (or in the circuit pump)</p> <p>Indicator light 3 red Shines</p> <p><b>Solution:</b> Load less fuel! Check the heat outtake!</p> <p>Reset: Undo the cover (8) and press the STB button placed underneath when the text „boiler temperature 85 °C “ is displayed! The error is automatically removed within few seconds.</p> <p><b>Emergency program:</b> NO</p> <p>Actions of the Automatic boiler stop.<br/>regulator: By the boiler temperature &gt; 86 °C, the outtake of the surplus heat is stopped<br/>V1 and V2 are adjusted after the setting is done</p> <p><b>If the error repeats, it is necessary to inform the service technician.</b></p> |
|---|--|

## Incorrectly measured values of the boiler temperature (error)

|  |   |  |
|--|---|--|
| Incorrectly measured boiler temperature<br>Boiler temperature (°C) | Cause:<br>Indicator light 3 red<br><b>Solution:</b><br><br>Reset:<br><b>Emergency program:</b><br>Actions of the regulator: | Measured values < -20 °C, or > +150 °C<br>Shines<br>Check the sockets and conductors! Replace the sensors, is necessary!<br>Automatically after the error is removed<br>NO<br>Automatic stop of the flue gas fan and the circuit pump<br>V1=0 %, V2= min. 25 %open |
|--|---|--|

## Too high flue gas temperature (warning)

|   |   |  |
|---|---|--|
| Very high flue gas temperature<br>Boiler temperature (°C) | Cause:<br>Indicator light 3 red:<br>Solution:<br><br>Reset:<br><br><b>Emergency program:</b><br>Actions of the regulator: | Flue gas temperature > 300 °C<br>Flickers<br>Close the door immediately by heating up and refilling the fuel<br>In operation: Clean the boiler after the fuel burns out<br>Automatically by the flue gas temperature < 299 °C<br>NO<br>Flue gas temperature > 350 °C, flue gas fan stop<br>Flue gas temperature < 299 °C, flue gas fan start |
|---|---|--|

## Overheating (warning)

|  |   |   |
|--|---|---|
| Overheating<br>DO NOT OPEN!<br>Boiler temperature (°C) | Cause:<br><br>Indicator light 3 red:<br>Solution:<br>Reset:<br><b>Emergency program:</b><br>Actions of the regulator: | The boiler is started and its temperature is > 90 °C<br>Too much fuel, fault of the circuit pump<br>Flickers<br>Load less fuel or remove the fault<br>Automatically by the boiler temperature of < 89 °C<br>NO<br>Boiler temperature > 90 °C, flue gas fan stop<br>V1=0 %, V2=min. 25 %open<br>Boiler temperature < 89 °C, flue gas fan start<br>V1 and V2 are adjusted after the setting is done |
|--|---|---|



### Incorrectly measured values of flue gas (error)

|  |   |
|--|---|
| <p>Error in temperature measuring<br/>Flue gas temperature ( °C)</p> | <p>Cause: Measured values &lt; -20 °C, or &gt; 499 °C<br/>Indicator light 2 yellow Shines<br/>Solution: Check the sockets and the inlet conductors! Replace the sensors, if necessary<br/>Reset: Automatically after the error is removed<br/><b>Emergency program:</b> YES; the burning down is possible<br/>Actions of the regulator: The regulator works with the amount of the alternative air V1, V2. The boiler must be stopped manually and the „-“ button and burn down. No line plot is displayed by warming up.</p> |
|--|---|

### Protection against freezing (warning)

|   |   |
|---|---|
| <p>Protection against freezing<br/>Boiler temperature ( °C)</p> | <p>Cause: The boiler temperature is &lt; 7 °C when it is switched off<br/>Indicator light 2 yellow: Shines<br/>Solution: Heat up and let it burn down<br/>Reset: Automatically with the next burning down („+“ button), or when the boiler temperature is &gt; 8 °C<br/><b>Emergency program:</b> YES, the burning down is possible – do that!<br/>Actions of the regulator: By the boiler temperature &lt; 7 °C: The circuit pump is started<br/>If there is a heat in the tank, it is taken out by this action. If there is no heat in the tank, in the circulating water is the freezing point decreased. By the boiler temperature &gt; 8 °C: The circuit pump is stopped</p> |
|---|---|

### Incorrectly measured values of the oxygen sensor– the Lambda probe (error)

|  |   |
|--|---|
| <p>Error in measuring the O<sub>2</sub><br/>Boiler temperature ( °C)</p> | <p>Cause: Unstable heating by sensor, fault in the electrical circuit or short circuit<br/>The indicator light 2 yellow Shines<br/>Solution: Check the sockets and conductors. Dismantle and clean the oxygen sensor. If it is necessary, replace it.<br/>Reset: Automatically after the error is removed and the new scale of the O<sub>2</sub> sensor is set.<br/><b>Emergency program:</b> YES, the burning down is possible<br/>Actions of the regulator: The regulator works with the amount of the alternative air V1, V2. The boiler must be stopped manually and the „-“ button .<br/><b>Not to shorten the service life of the boiler, it is necessary to remove the fault immediately! The guarantee could get invalid!</b></p> |
|--|---|

## Errors, functions and actions of the regulator – summary

| <b>Errors and functions</b>   | <b>Actions or operation of the regulator</b>   |
|---|--|
| Power shortage  | After the power supply is restored, the operation state is reset as it was before the power shortage (the boiler is started or stopped again).   |
| Too high boiler temperature   | < 90 °C: the fan is stopped<br>> 89 °C: the fan is started   |
| Incorrectly measured values of the boiler temperature   | The flue gas fan and the supply pump are stopped. The boiler cannot be started.  |
| Incorrectly measured values of flue gas   | The boiler can be started. The regulator works with the alternative air V1 and V2. It is necessary to turn the boiler off manually after burning down!   |
| Incorrectly measured values of O <sub>2</sub> sensor (Lambda probe)                           | No line plot is displayed during the heating up.<br>It is possible to start the boiler, the regulator works with the alternative air V1 and V2.  |
| Automatic stop function by the flue gas sensor  | If the boiler works for 30 minutes and the flue gas temperature decreases by 25 % during 15 minutes, the boiler is stopped.  |
| The STB is started  | The surplus heat outtake is stopped if the boiler temperature is < 85 °C. Then, if the boiler temperature increases > 86 °C, the surplus heat outtake.   |
| Function of the switch contact  | When the boiler is in operation: WK/AK is closed<br>When the boiler is turned off and the flue gas temperature is < 100 °C: WK/RK is closed  |
| The CPU error   | All the relays are turned off by the Hardware Watchdog   |
| Protection against freezing   | By the boiler stopped with the temperature < 7 °C:<br>Start of the supply pump, Y1 and Y2 = 100 %.<br>If the boiler temperature increases to > 8 °C, the supply pump is stopped.<br>Y1=0 %, Y2= 100 %. |
| Protection of the flue gas fan and the flue gas sensor against overheating                    | Flue gas temperature > 350 °C, the flue gas fan is turned off<br>Flue gas temperature < 299 °C, the flue gas fan is turned on  |
| Short circuit of the „+“ button   | Button of the regulator does not react even to a significant pressure  |
| Function of access (Menu)   | The menu automatically disappears after the safety time elapses  |
| Safety test   | Takes max. 30 min and it is automatically terminated or interrupted, if the boiler temperature is > 110 °C, or the „+“ button has not been pressed for 30 seconds                                      |
| Operating range of the automatic adjustment of the return connection to the particular value. | Between 60 °C and 80 °C  |
| Operation without settings is controlled by technician  | The regulator is adjusted after the setting by producer.   |
| Data storing  | Only when there is enough energy > 160V.   |

### 4.33 CHARACTERISTICS OF THE WATER TEMPERATURE SENSOR (THE PROFI VERSION)

| Temperature °C | MIN   | Resistance to $\Omega$ | MAX   |
|----------------|-------|------------------------|-------|
| -55            | 951   | 980                    | 1 009 |
| -50            | 1 000 | 1 030                  | 1 059 |
| -40            | 1 105 | 1 135                  | 1 165 |
| -30            | 1 218 | 1 247                  | 1 277 |
| -20            | 1 338 | 1 367                  | 1 396 |
| -10            | 1 467 | 1 495                  | 1 523 |
| 0              | 1 603 | 1 630                  | 1 656 |
| 10             | 1 748 | 1 772                  | 1 797 |
| 20             | 1 901 | 1 922                  | 1 944 |
| 25             | 1 980 | 2 000                  | 2 020 |
| 30             | 2 057 | 2 080                  | 2 102 |
| 40             | 2 217 | 2 245                  | 2 272 |
| 50             | 2 383 | 2 417                  | 2 451 |
| 60             | 2 557 | 2 597                  | 2 637 |
| 70             | 2 737 | 2 785                  | 2 832 |
| 80             | 2 924 | 2 980                  | 3 035 |
| 90             | 3 118 | 3 182                  | 3 246 |
| 100            | 3 318 | 3 392                  | 3 466 |
| 110            | 3 523 | 3 607                  | 3 691 |
| 120            | 3 722 | 3 817                  | 3 912 |
| 125            | 3 815 | 3 915                  | 4 016 |
| 130            | 3 901 | 4 008                  | 4 114 |
| 140            | 4 049 | 4 166                  | 4 283 |
| 150            | 4 153 | 4 280                  | 4 407 |

### 4.34 ELECTRICAL SCHEMES OF CONNECTION OF THE BOILERS ATTACK DPX STANDARD, LAMBDA

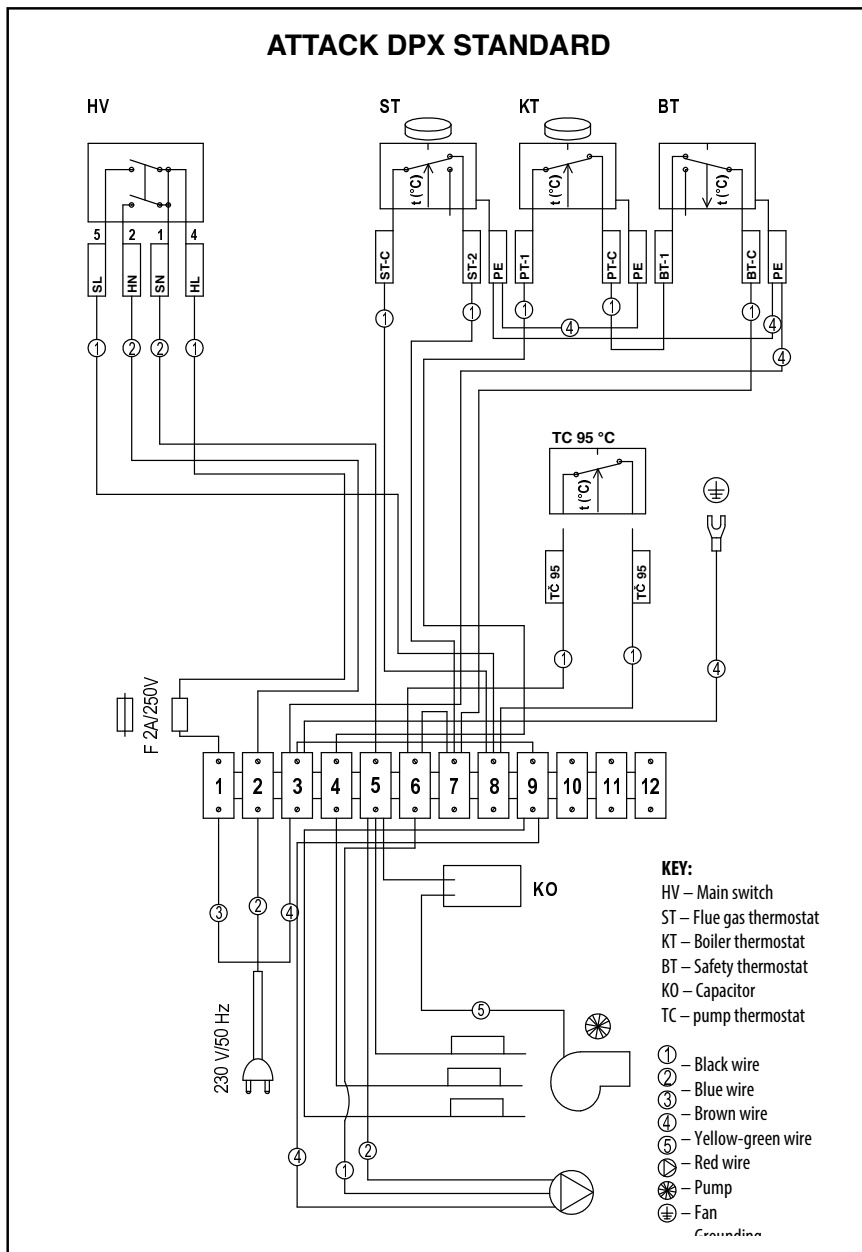

### 4.35 ATTACK DPX PROFI

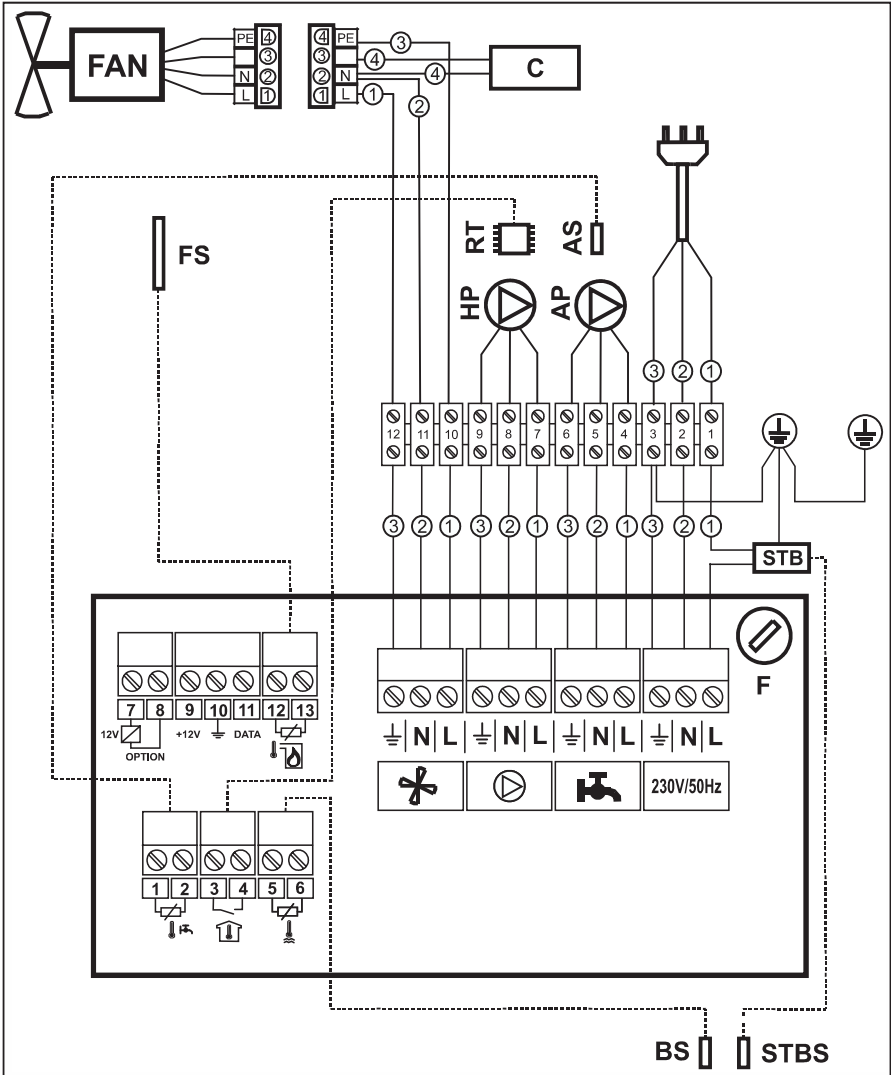

- BS** – boiler temperature sensor
- STBS** – sensor of emergency thermostat
- HP** – circuit pump
- AP** – additional pump
- AS** – additional sensor
- RT** – room thermostat
- FS** – flue gas temperature sensor

- FAN** – ventilator
- STB** – emergency thermostat
- F** – Fuse (2A)
- C** – Capacitor
- 1** – black wire
- 2** – blue wire
- 3** – yellow-green wire

### 4.36 ATTACK DPX LAMBDA

Connection to the mains from the bottom part of the regulator

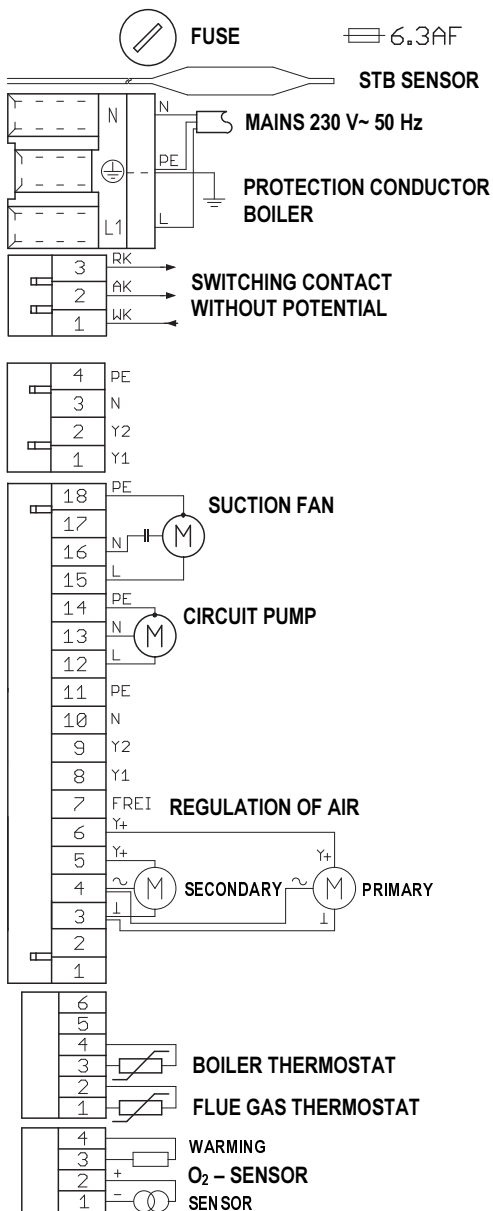

## Oxygen sensor(Lambda probe)

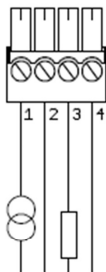

Terminal 1: Sensor –  
Terminal 2: Sensor +  
Terminal 3: Sensor warming  
Terminal 4: Sensor warming

4-wire flexi cable covered by silicone with the section of conductor of 0,75 mm<sup>2</sup>



white = warming 12 V≈

black = + signal of sensor

grey = – signal of sensor

## Temperature sensor

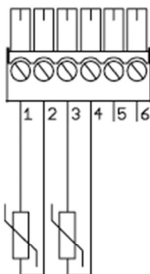

Terminal 1: Flue gas sensor F1 Pt100  
Terminal 2: Flue gas sensor F1 Pt100  
Terminal 3: Boiler sensor F2 Pt100  
Terminal 4: Boiler sensor F2 Pt100  
Terminal 5:  
Terminal 6:

Values of the resistance:

T = 0 °C R = 100,0Ω

T = 20 °C R = 107,8Ω

T = 100 °C R = 138,5Ω

T = 200 °C R = 175,8Ω

Fix the flue gas sensor into the flue connection by the bayonet flange!

Do not extend the connection conductors of the sensors!

Treat the boiler sensor and the safety thermostat sensor by a warm-water paste, put it into the casing and fix by a spring!

Polarity is not important.

## Air flap V1 – V2, circuit pump, suction fan

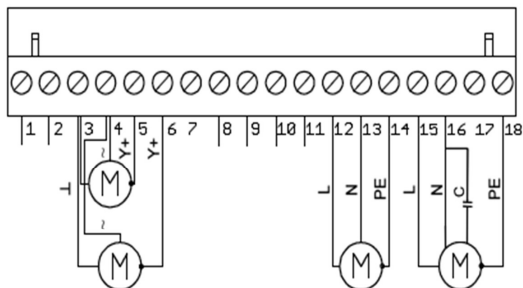

Use the 3-wire flexi cable with the section of 0,75 mm<sup>2</sup> to connect the circuit pump and the suction fan

C: STARTING CAPACITOR

Terminal 3: Connection ⊥  
Terminal 4: Connection 24V~  
Terminal 5: Regulation signal sec. Y+ (0/2 – 10V)  
Terminal 6: Regulation signal prim. Y+ (0/2 – 10V)

Terminal 12: L: Circuit pump  
Terminal 13: N: Circuit pump  
Terminal 14: PE: Circuit pump  
Terminal 15: L: Suction fan  
Terminal 16: N: Suction fan  
Terminal 17: Free  
Terminal 18: PE: Suction fan

## Electrical voltage 230V

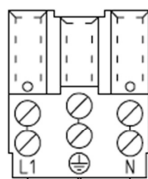

L1: Phase  
 PE: Grounding  
 N: Zero wire

Mains circuit breaker max. 10 A  
 Three-wire flexi cable 1,5 mm<sup>2</sup>

Caution! The covering of the boiler must be earthed by the grounding of the supply cord!

Grounding  
 of the covering

Mains cable  
 ~230 V/50 Hz  
 -15 %/+10 %

**N** – Neutral wire

**PE** – Grounding wire

**L** – Phase

**WK** – Main contact relay

**AK** – Normally open contact relay

**RK** – Normally closed contact relay



## 5 RECOMMENDED SCHEMES OF CONNECTION

### 5.1 CONNECTION OF THE BOILER WITH 1 HEATING CIRCUIT WITH DHW

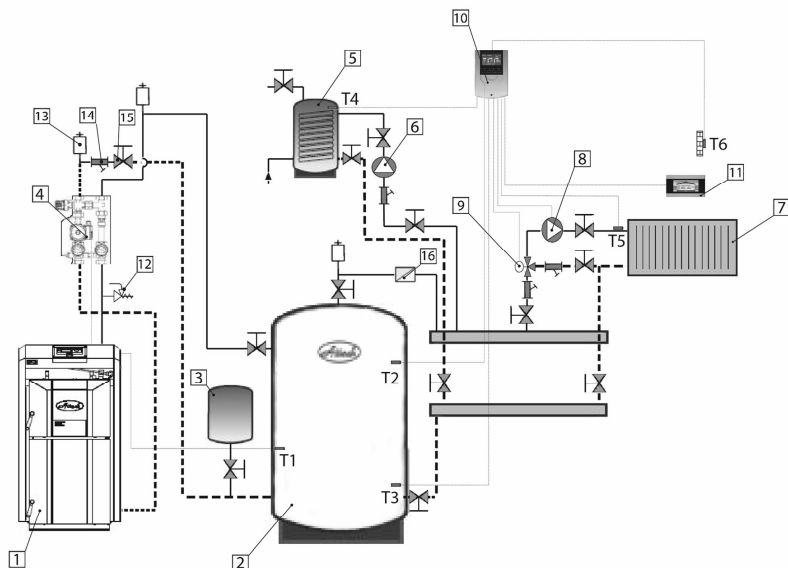

- 1 Wood gasifying boiler ATTACK DPX with regulation PROFI PID
- 2 Accumulation tank ATTACK
- 3 Expanse vessel
- 4 Mixing device ATTACK OVENTROP with pump class A
- 5 Tank for DHW
- 6 Pump of tank for DHW (WILO YONOS PARA RS25/6 130 mm, WILO YONOS PARA RS 25/6 RKC 180mm)
- 7 Set of radiators ATTACK K, VK
- 8 Pump of heating circuit of radiators (WILO YONOS PARA RS25/6 130 mm; WILO YONOS PARA RS25/6 RKC 180 mm)
- 9 Three-way mixing valve of radiators (DN20, KVS 2,5; DN20, KVS 4,0; DN20, KVS 6,3; DN20, KVS 10; DN32, KVS 16; DN40, KVS 25; DN50, KVS 40)
- 10 Regulator 1 mixing circuit TECH CS-431N
- 11 Room regulator (TECH CS-292 V3, CS-296 with RS communication, CS-282 with RS communication)
- 12 Safety valve
- 13 Deaeration valve
- 14 Filter
- 15 Ball tap
- 16 Return(backflow) valve
- T1 Boiler temperature sensor in accumulation tank
- T2,3 Additional temperature sensor in accumulation tank
- T4 Additional temperature sensor in DHW tank
- T5 Additional temperature sensor in radiators
- T6 Additional sensor of external temperature

## 5.2 CONNECTION OF THE BOILER WITH 1 HEATING CIRCUIT WITHOUT DHW

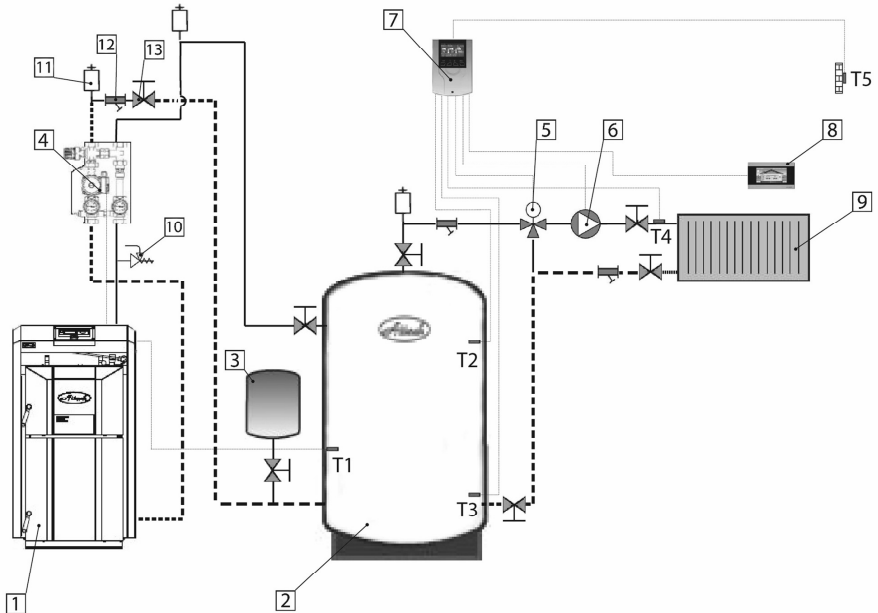

- 1 Wood gasifying boiler ATTACK DPX with regulation PROFI PID
- 2 Accumulation tank ATTACK
- 3 Expanse vessel
- 4 Mixing device ATTACK OVENTROP with pump class A
- 5 Three-way mixing valve of radiators (DN20, KVS 2,5; DN20, KVS 4,0; DN20, KVS 6,3; DN20, KVS 10; DN32, KVS 16; DN40, KVS 25; DN50, KVS 40)
- 6 Pump of heating circuit of radiators (WILO YONOS PARA RS25/6 130 mm; WILO YONOS PARA RS25/6 RKC 180 mm)
- 7 Regulator 1 mixing circuit TECH CS-431N
- 8 Room regulator (TECH CS-292 V3, CS-296 with RS communication, CS-282 with RS communication)
- 9 Set of radiators ATTACK K, VK
- 10 Safety valve
- 11 Deaeration valve
- 12 Filter
- 13 Ball tap
- T1 Boiler temperature sensor in accumulation tank
- T2,3 Additional temperature sensor in accumulation tank
- T4 Additional temperature sensor in radiators
- T5 Additional sensor of external temperature

### 5.3 CONNECTION OF THE BOILER WITH 2 HEATING CIRCUITS WITHOUT DHW

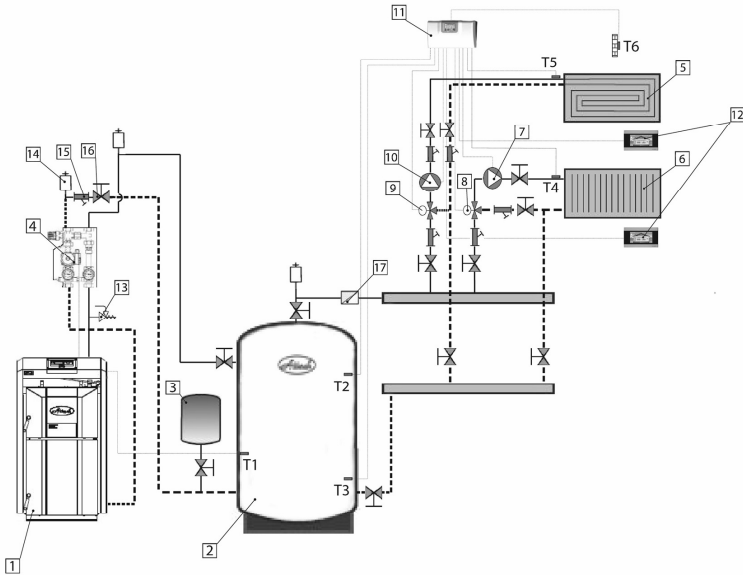

- 1 Wood gasifying boiler ATTACK DPX with regulation PROFI PID
- 2 Accumulation tank ATTACK
- 3 Expanse vessel
- 4 Mixing device ATTACK OVENTROP with pump class A
- 5 Floor heating system
- 6 Set of radiators ATTACK K, VK
- 7 Pump of heating circuit of radiators (WILO YONOS PARA RS25/6 130 mm; WILO YONOS PARA RS25/6 RKC 180 mm)
- 8 Three-way mixing valve of radiators (DN20, KVS 2,5; DN20, KVS 4,0; DN20, KVS 6,3; DN20, KVS 10; DN32, KVS 16; DN40, KVS 25; DN50, KVS 40)
- 9 Three-way mixing valve of the floor heating (DN20, KVS 2,5; DN20, KVS 4,0; DN20, KVS 6,8; DN25, KVS 10; DN32, KVS 16; DN40, KVS 25; DN50, KVS 40)
- 10 Pump of floor heating circuit (WILO YONOS PARA RS25/6 RKC 130 mm, WILO YONOS PARA RS25/6 RKC 180 mm)
- 11 Regulator of 2 heating circuits TECH CS-408N
- 12 Room regulator with RS communication TECH CS-282, CS-292 V3, CS-296 (always only 1 with RS communication)
- 13 Safety valve
- 14 Deaeration valve
- 15 Filter
- 16 Ball tap
- 17 Return(backflow) valve
- T1 Boiler temperature sensor in accumulation tank
- T2,3 Additional temperature sensor in accumulation tank
- T4 Additional temperature sensor in radiators
- T5 Additional temperature sensor in floor
- T6 Additional sensor of external temperature

## 5.4 CONNECTION OF THE BOILER WITH 2 HEATING CIRCUITS WITH DHW

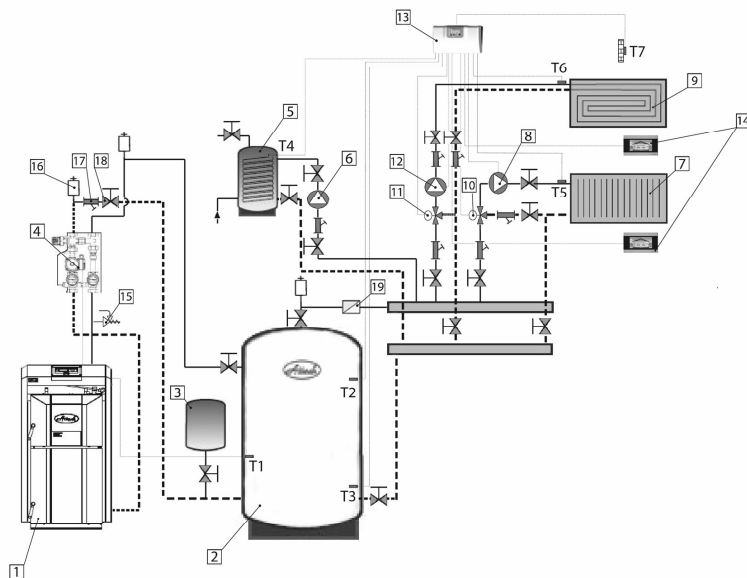

- 1 Wood gasifying boiler ATTACK DPX with regulation PROFI PID
- 2 Accumulation tank ATTACK
- 3 Expanse vessel
- 4 Mixing device ATTACK OVENTROP with pump class A
- 5 Tank for DHW
- 6 Pump of tank for DHW (WILO YONOS PARA RS25/6 130 mm, WILO YONOS PARA RS 25/6 RKC 180mm)
- 7 Set of radiators ATTACK K, VK
- 8 Pump of heating circuit of radiators (WILO YONOS PARA RS25/6 130 mm; WILO YONOS PARA RS25/6 RKC 180 mm)
- 9 Floor heating system
- 10 Three-way mixing valve of radiators (DN20, KVS 2,5; DN20, KVS 4,0; DN20, KVS 6,3; DN20, KVS 10; DN32, KVS 16; DN40, KVS 25; DN50, KVS 40)
- 11 Mixing valve of floor
- 12 Pump of floor heating circuit (WILO YONOS PARA RS25/6 RKC 130 mm, WILO YONOS PARA RS25/6 RKC 180 mm)
- 13 Regulator of 2 heating circuits TECH CS-408N
- 14 Room regulator with RS communication TECH CS-282, CS-292 V3, CS-296 (always only 1 with RS communication)
- 15 Safety valve
- 16 Deaeration valve
- 17 Filter
- 18 Ball tap
- 19 Return(backflow) valve
- T1 Boiler temperature sensor in accumulation tank
- T2,3 Additional temperature sensor in accumulation tank
- T4 Additional temperature sensor in DHW tank
- T5 Additional temperature sensor in radiators
- T6 Additional temperature sensor in floor
- T7 Additional sensor of external temperature

# EC DECLARATION OF CONFORMITY

POZ-059/02012019

I, Rudolf Bakala, the corporate representative of the ATTACK, s.r.o. company, declare, that the products mentioned below fulfil requirements of the technical prescriptions, under conditions specified for using they are safe, they are produced in conformity with Instruction for use and installation, technical documentation and with the norms and regulations given in this document.

**Manufacturer:** ATTACK, s.r.o., Dielenská Kružná 5020, 03861 Vrútky, Slovak Republic

**Place of manufacture:** ATTACK, s.r.o., Dielenská Kružná 5020, 03861 Vrútky, Slovak Republic

**Product:** Hot-water solid fuel boiler

**Type:** **ATTACK DPX 15 STANDARD, ATTACK DPX 15 PROFI, ATTACK DPX 15 LAMBDA  
ATTACK DPX 25 STANDARD, ATTACK DPX 25 PROFI, ATTACK DPX 25 LAMBDA  
ATTACK DPX 30 STANDARD, ATTACK DPX 30 PROFI, ATTACK DPX 30 LAMBDA  
ATTACK DPX 35 STANDARD, ATTACK DPX 35 PROFI, ATTACK DPX 35 LAMBDA  
ATTACK DPX 40 STANDARD, ATTACK DPX 40 PROFI, ATTACK DPX 40 LAMBDA  
ATTACK DPX 45 STANDARD, ATTACK DPX 45 PROFI, ATTACK DPX 45 LAMBDA  
ATTACK DPX 80 STANDARD, ATTACK DPX 80 PROFI  
ATTACK DPX 100 STANDARD, ATTACK DPX 100 PROFI**

## Description:

The hot-water boilers for wood log combustion. The boilers are intended to be a heat source for dwelling houses and similar objects. The boilers are constructed to work on principle of wood gasification by utilization of the exhaust fan, which sucks the flue into the chimney.

## The following European Directives are related to the products:

- Directive of the European Parliament and of the Council of Europe 2014/35/ES
- Directive of the European Parliament and of the Council of Europe 2014/30/ES
- Directive of the European Parliament and of the Council of Europe 2014/68/ES
- Directive of the European Parliament and of the Council of Europe 2006/42/ES

## List of the Harmonized Norms, used by consideration of conformity:

- **STN EN 303-5:2012** Central heating boilers – Part 5: Central heating boilers burning solid fuels, with manual or automatic fuel feeding and rated heat capacity of up to 500 kW – Terminology, requirements, testing and marking (idt EN 303-5:2012)
- **STN EN 15036-1:2007** Heating boilers – Test regulations for airborne noise emissions from heat generators – Part 1: Airborne noise emissions from heat generators
- **STN EN 60335-1:2012/AC:2014** Electrical appliances for household and similar purposes. Safety. Part 1: General requirements (idt EN 60335-1:2012)
- **STN EN 60335-2-102:2007/A1:2010** Electrical appliances for household and similar purposes. Safety. Part 2-102: Particular requirements for appliances with electrical connection, combusting gas, liquid and solid fuels (idt EN 60335-2-102:2006/A1:2010)
- **STN EN 55014-1:2007/A1:2010/A2:2012** Electromagnetic compatibility – Requirements on home appliances, home tools and similar devices – Part 1: Radiation (idt EN 55014-1:2006/A1:2009/A2:2011)
- **STN EN 62233:2008** Methods of measuring of electromagnetic arrays of home appliances and similar devices with regards to exposition of persons
- **STN EN 55014-1:2017** Electromagnetic compatibility – Requirements on home appliances, home tools and similar devices – Part 1: Radiation
- **ČSN 06 1008:1997** Fire safety of heat equipment
- **STN EN 61000-6-2:2006** Electromagnetic compatibility (EMC) – Part 6-2: General norms – Immunity for industrial environments
- **STN EN 61000-6-3:2007** Electromagnetic compatibility (EMC) - Part 6-3: Generic standards - Emission standard for residential, commercial and light-industrial environments
- **STN EN 61000-3-2:2015** Electromagnetic compatibility (EMC) - Part 3-2: Limits – Limits of radiation of harmonic parts of current (devices with input phase current  $\leq 16$  A)
- **STN EN 61000-3-3:2014** Electromagnetic compatibility (EMC) - Part 3-3: Limits - Limiting changes, voltage fluctuations and flicker in low voltage public grids for equipment with rated current  $\leq 16$  A, which is not subject to a conditional connection
- **STN EN ISO 11202:2011** Acoustics. Noise emitted by machinery and equipment. Determination of emission sound pressure levels at a work station and at other specified positions applying approximate environmental corrections (ISO 11202:2010)
- **STN EN ISO 3746:2012** Acoustics. Determination of sound power levels and sound energy levels of noise sources using sound pressure. Survey method using an enveloping measurement surface over a reflecting plane (ISO 3746: 2010)

## Notified body, who performed tests and judgement of conformity:

STROJIRENSKÝ ZKUŠEBNÍ ÚSTAV, s.p., Hudcova 56b, 621 00 BRNO, Czech Republic, Notified body 1015

## Notified body, performing inspections and control of the quality system:

STROJIRENSKÝ ZKUŠEBNÍ ÚSTAV, s.p., Hudcova 56b, 621 00 BRNO, Czech Republic, Notified body 1015

**Last double digit of the year, when the CE marking was placed on the product:** 19

In Vrútky: 02.01.2019

.....  
Rudolf Bakala, Executive manager ATTACK, s.r.o. Vrútky



# WOOD GASIFYING BOILER ATTACK® SLX, DPX



*USER MANUAL*  
*for correct installation,*  
*operation and cleaning*



WWW.ATTACK.SK

**Important! Read this manual properly before the boiler start-up!**

# CONTENTS

|   |    |
|---|----|
| 1. INSTALLATION AND CHIMNEY PARAMETERS.....                                 | 4  |
| 2. VERIFICATION OF THE CORRECT CHIMNEY PARAMETERS .....                     | 5  |
| 3. DEVICES FOR CHIMNEY DRAUGHT MEASURING .....                              | 6  |
| 4. OPERATION PRESSURE IN HYDRAULIC CIRCUIT .....                            | 7  |
| 5. BOILER PROTECTION AGAINST EXCESSIVE CONDENSATION – ATTACK-OVENTROP ..... | 7  |
| 6. CORRECT ASHTRAYS POSITION.....   | 8  |
| 7. FUEL.....  | 8  |
| 8. AFTERCOOLING CIRCUIT INSTALLATION .....                                  | 9  |
| 9. CORRECT ADJUSTMENT OF AIR INLETS.....                                    | 9  |
| 10. ASHTRAY CLEANING.....   | 10 |
| 11. HOW TO CLEAN SPACE AROUND THE ASHTRAY .....                             | 12 |
| 12. EXCHANGER PIPES CLEANING BY LEVER OF TURBULATORS .....                  | 13 |
| 13. HOW TO CLEAN SPACE UNDER EXCHANGER .....                                | 14 |
| 14. POSITION OF LEVER OF TURBULATORS BY CLEANING .....                      | 15 |
| 15. TOOLS FOR CLEANING OF SPACE UNDER EXCHANGER.....                        | 16 |
| 16. CONTROL OF TUBULAR EXCHANGER’S FUNCTIONALITY .....                      | 17 |
| 17. ACCESS TO TUBULAR EXCHANGER .....                                       | 17 |
| 18. EXCHANGER’S COVER REMOVAL .....   | 18 |
| 19. CONTROL OF CORRECT FUNCTION OF THE HEAT-UP FLAP .....                   | 18 |
| 20. TURBULATOR THREADS CLEANING.....  | 19 |
| 21. CLEANING OF THE VENTILATOR’S OPERATION AREA .....                       | 20 |
| 22. CLEANING OF RADIAL IMPELLER’S VANES.....                                | 21 |
| 23 SUMMARY OVERVIEW OF REGULAR CLEANING OF PARTICULAR BOILER PARTS .....    | 22 |

## 1. INSTALLATION AND CHIMNEY PARAMETERS

By installation of chimney connection to boiler it is necessary to care about correct outlet of flue gas and eventual condensate, not to let it fall back into the boiler. For this purpose you can use the T-piece, see picture below. Exhaust connection comes into the chimney vent. If it is not possible to connect boiler to chimney vent directly, then the adequate extension of exhaust connection has to be as short as possible, and no longer than 1 m, without additional heating surface and it has to go up in direction to the chimney. Exhaust connections must not go through foreign dwelling or utility units. Internal cross-section of the exhaust connection must not taper in direction to the chimney. Try to minimize usage of elbows by installation. Chimney has to be constructed in conformity with the norms **STN 73 4201** and **STN 73 4210**.



**Prescribed values of the correct height and cross-section chimney dimensions:**

|                                   |                        |
|-----------------------------------|------------------------|
| <i>DPX15, DPX25, DPX35, DPX45</i> |                        |
| <i>20x20 cm</i>                   | <i>min height 7 m</i>  |
| <i>Ø 20 cm</i>                    | <i>min. height 8 m</i> |
| <i>15x15 cm</i>                   | <i>min height 11 m</i> |
| <i>Ø 16 cm</i>                    | <i>min height 12 m</i> |



## 2. VERIFICATION OF THE CORRECT CHIMNEY PARAMETERS

Correct boiler function significantly depends on quality chimney with correct parameters. Minimum chimney diameter is 150 mm, however, 200 mm is recommended. Chimney has to be designed or regulated to achieve prescribed draught of 23–30 Pa at nominal boiler flue gas temperature value.



**ATTENTION! Chimney which does not fulfil required parameters may cause limited boiler function (Low flue gas temperature, low output, excessive condensation of tubular exchanger, shorter life-time, even total boiler disfunction)! Guarantee does not relate to the boiler installed with the chimney of incorrect parameters.**

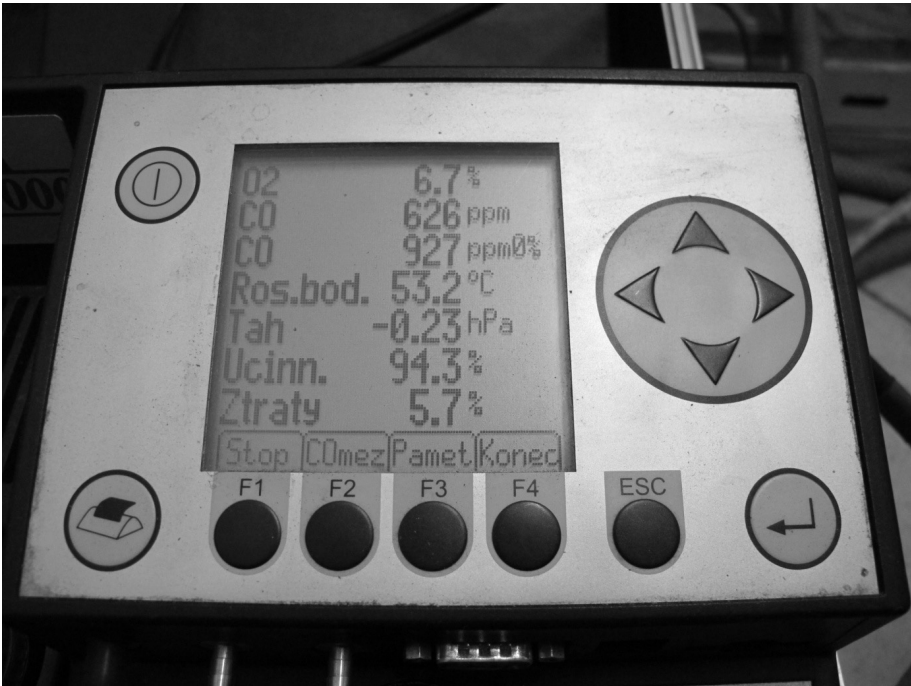

### 3. DEVICES FOR CHIMNEY DRAUGHT MEASURING

It is possible to check correct chimney draught by some types of analysers or by exact differential pressure-gauge. On the picture there is draught reducer too, also useful for correct draught setting.



## 4. OPERATION PRESSURE IN HYDRAULIC CIRCUIT



Operation pressure must not exceed limit of 2,5 bar.

**ATTENTION! Expanse vessel and safety valve must be installed in the system.**



## 5. BOILER PROTECTION AGAINST EXCESSIVE CONDENSATION – ATTACK-OVENTROP

For correct boiler function and its long life-time it is necessary to keep return water temperature always higher than 65 °C. Set boiler thermostat to 80-85 °C, which is ideal boiler operation temperature. Boiler guarantee is valid only in case that the ATTACK-OVENTROP device was installed into the hydraulic system.



**ATTENTION! If the ATTACK OVENTROP device is not installed, it may cause shorter boiler life-time.**



## 6. CORRECT ASHTRAYS POSITION

Ashtray position is important for correct boiler operation. It is not necessary to take out the ashtray while cleaning, but it is important to check its correct position sometimes. Ashtray has to be completely shifted rearwards.



## 7. FUEL

Use suitable fuel for wood gasifying boiler operation – soft or hard wood logs. Wood moisture has to be in range of 12–20 % (related to time of min. 15 month of free storing at the fresh air). Alternatively it is possible to use wood briquets of cylindrical shape with opening in the middle.



**ATTENTION! Wood with moisture exceeding 20 % shortens boiler life-time, causes lower output, excessive condensation in tubular boiler exchanger, which may require additional out-of-warranty service!**



## 8. AFTERCOOLING CIRCUIT INSTALLATION

Boiler warranty is valid only in case, that functional thermostatic valve, connected to the cold water source, is installed in the boiler aftercooling circuit. If the cold water source depends on electricity (home water plant), whole device can be out of order in case of power failure. In this cases, use water tanks placed higher than boiler, connected to thermostatic valve. Tank volume has to be appropriate to the boiler output.



**ATTENTION! If there is no aftercooling circuit on the boiler and it comes to boiler overheating, serious and non-recurring damage or even fire may occur.**

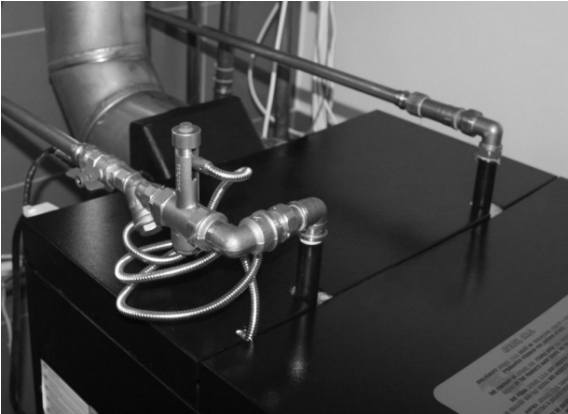

## 9. CORRECT ADJUSTMENT OF AIR INLETS

Correct adjustment of primary and secondary air by STANDARD and PROFI boilers is marked on tin-plate and it is not necessary to manipulate with that. Correct setting of primary air (upper butterfly) is 100 %, secondary air (bottom butterfly) is set to 35 %. This relates to all outputs of DPX boilers (15, 25, 35, 45).

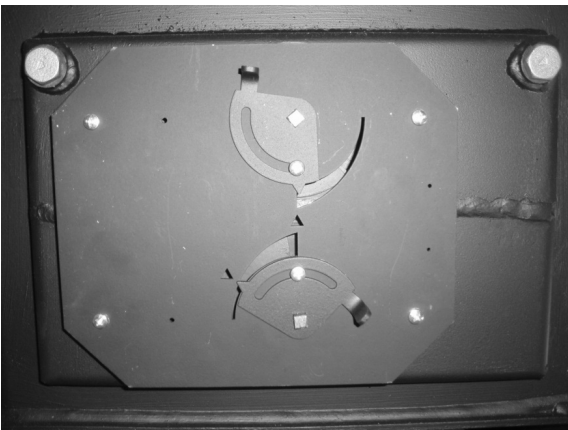

## 10. ASHTRAY CLEANING

Internal space of ashtray has to be cleaned from accumulated ash at least 1× a day. Cleaning with scoop is very effective and easy. Cleaning can be done very easily and fast also by full boiler operation.



**ATTENTION! Hot ash from ashtray can still smoulder, therefore it is not supposed to be put into trash bin, however into appropriate tin-plate bin, not to cause the fire.**







## 11. HOW TO CLEAN SPACE AROUND THE ASHTRAY

Space around the ashtray has to be cleaned regularly, at least 1× a week. Use suitable tool, fire hook delivered with boiler is ideal for this purpose. It is not necessary to take out the refractory pieces from the boiler's ashtray.



**ATTENTION! Unsufficiently cleaned space around ashtray may cause limited boiler function.**





## 12. EXCHANGER PIPES CLEANING BY LEVER OF TURBULATORS

It is necessary to move lever of turbulators cleaning regularly, preferably by every boiler loading, at least 3 times a day. It is necessary to move it by full lever uplift, 5-6 times upwards and downwards.



**ATTENTION! If it is not moved with the lever regularly, exchanger pipes may clog and therefore cause turbulators blockage, lower efficiency, decreased output and incorrect boiler function. In this case is boiler warranty not valid. If you cannot move the lever of turbulators, stop the boiler and call specialized service.**

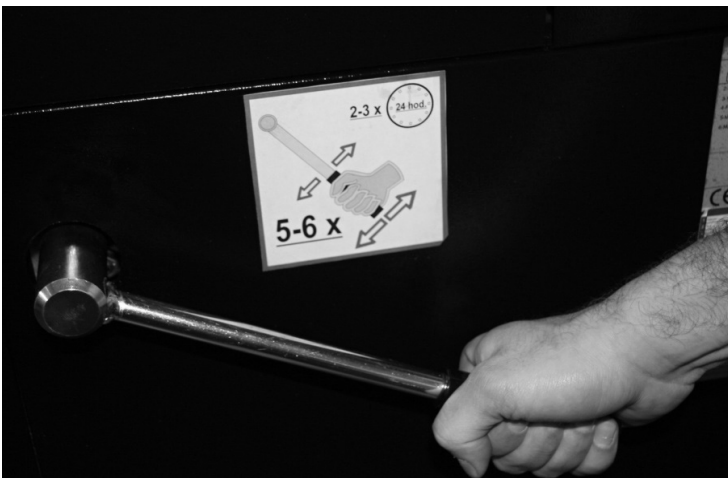
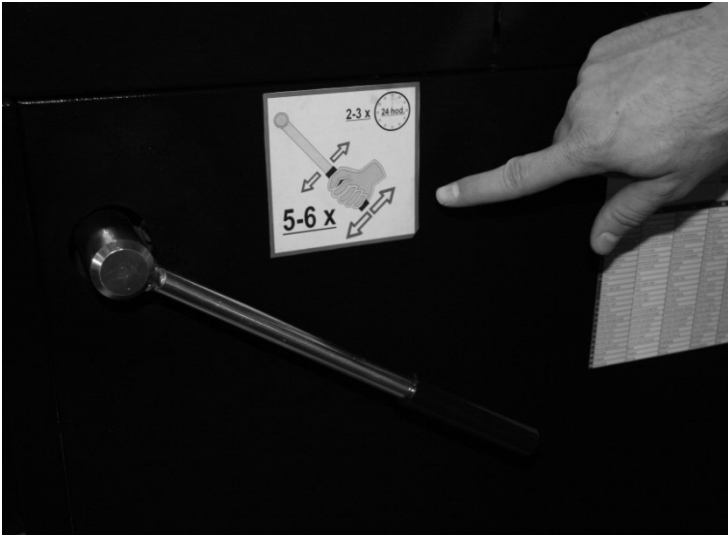

### 13. HOW TO CLEAN SPACE UNDER EXCHANGER

It is necessary to clean space under exchanger pipes in regular intervals. This interval depends on boiler operation time, but it has to be done at least 1× a week. Remove cover of the opening for cleaning carefully, not to damage the sealing. After cleaning of space under exchanger, install the cover – it has to be sufficiently screwed and air-proof.



**ATTENTION! Otherwise there may come to insufficient air circulation in the boiler and thereby to incorrect boiler function (ineffective combustion, decreased output, low flue gas temperature, etc.).**

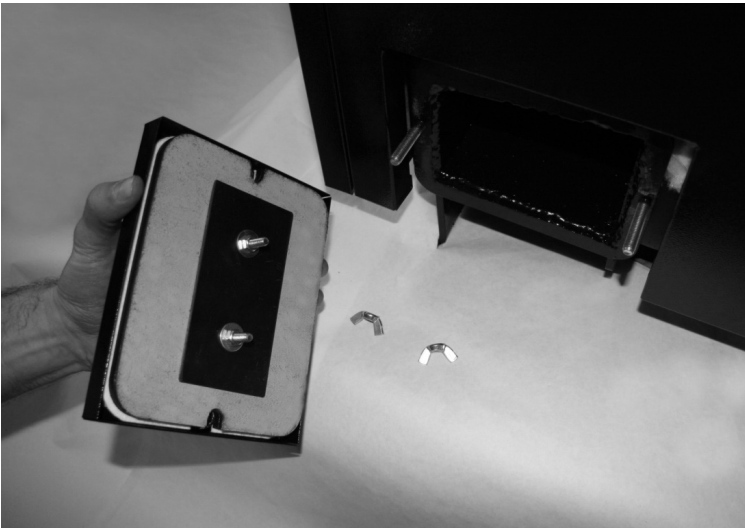

## 14. POSITION OF LEVER OF TURBULATORS BY CLEANING

To clean space under exchanger of the DPX 15, 25, 35 boilers, it is necessary to lift lever of turbulators fully up, turbulators go into the pipes and thereby there is free space for cleaning. By the DPX 45 boiler it is ideal to lift the lever into middle position.

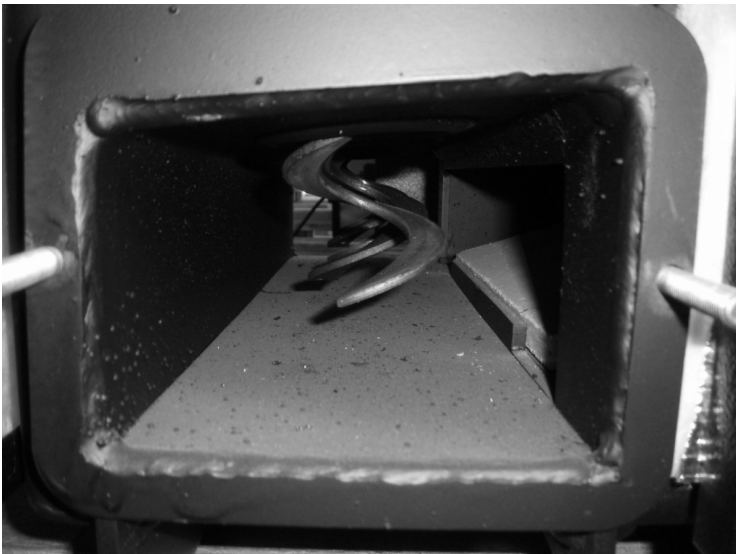

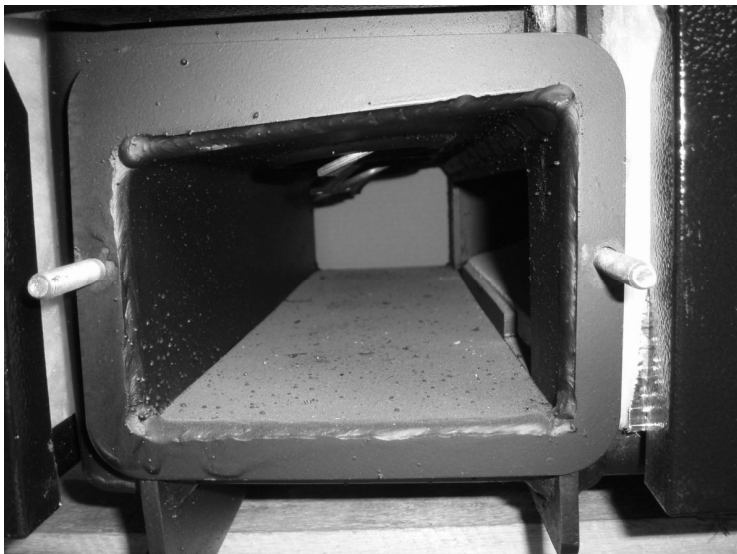

## 15. TOOLS FOR CLEANING OF SPACE UNDER EXCHANGER

To clean space under exchanger it is possible to use fire hook delivered with the boiler.

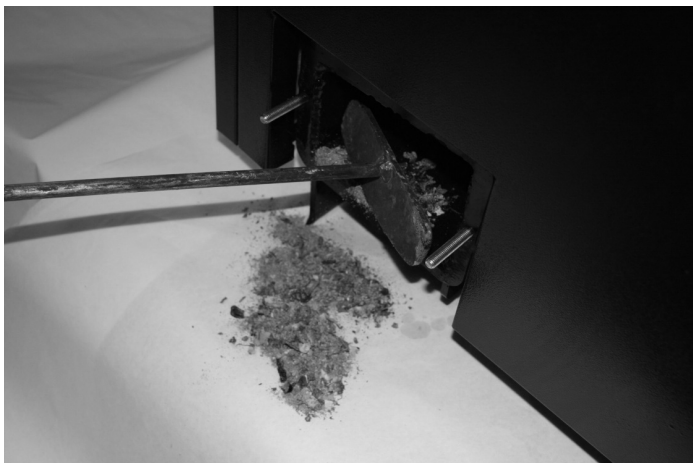

## 16. CONTROL OF TUBULAR EXCHANGER'S FUNCTIONALITY

Check regularly correct functionality of tubular exchanger – at least 1× a month. Firstly, remove rear upper cover.

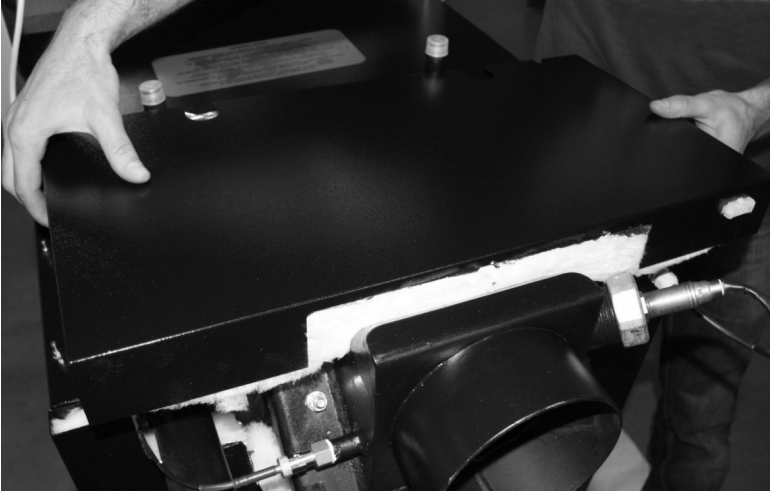

## 17. ACCESS TO TUBULAR EXCHANGER

Release wing matrices.

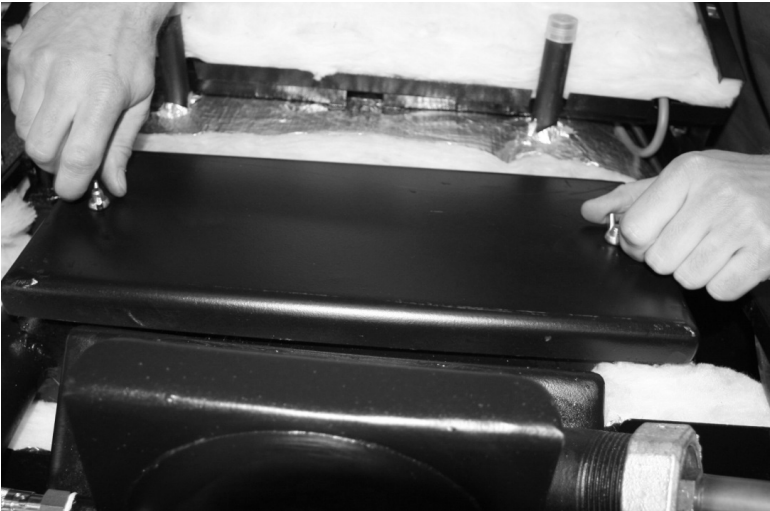

## 18. EXCHANGER'S COVER REMOVAL

Check correct functionality fo turbulators, while the boiler is out of order. Remove the cover to get to the tubular exchanger.



**ATTENTION! Cover must be sufficiently tighten and air-proof. Otherwise it may cause incorrect boiler function**



## 19. CONTROL OF CORRECT FUNCTION OF THE HEAT-UP FLAP

For correct function of the heat-up flap it is necessary to check and clean bearing surfaces regularly.



## 20. TURBULATOR THREADS CLEANING



If the boiler was from any reason operated in incorrect way, it is possible, that the turbulators were clogged and thereby the flue gas transition was decreased. In this case it is necessary to demount turbulators and to clean the space between particular threads, for example by wire brush. Put the turbulators back into the pipes, not to decrease efficiency of the boiler. (This is not related to the 15 DPX model).



## 21. CLEANING OF THE VENTILATOR'S OPERATION AREA

Operation space of the ventilator's radial impeller has to be cleaned at least 1× a year. To do so, release matrices of the ventilator's flange and demount ventilator. Clean the operation area from soot and mud. By demounting, take care to tighten matrices of the ventilator's flange sufficiently.



**ATTENTION! Demount ventilator, while boiler is out of order. Insufficiently cleaned ventilator's operation area may cause its limited function.**





## 22. CLEANING OF RADIAL IMPELLER'S VANES

Vanes of ventilator have to be cleaned from dirt at least 1× a year by suitable tool (wire brush).



**ATTENTION! Too dirty vanes of ventilator decrease its efficiency and thereby cause limited boiler function.**

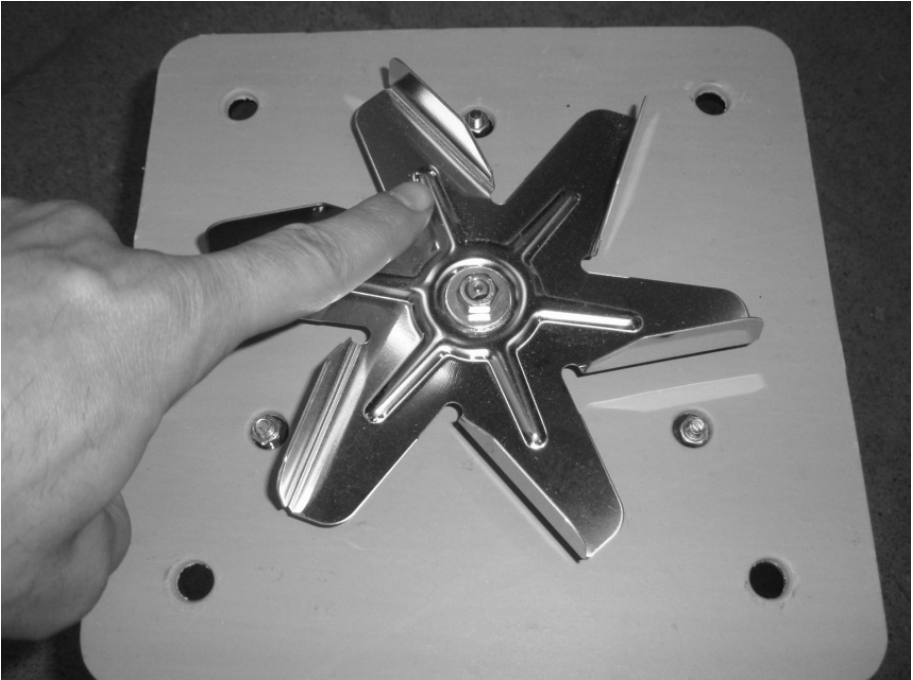

## 23 SUMMARY OVERVIEW OF REGULAR CLEANING OF PARTICULAR BOILER PARTS

| <b>Cleaning*</b>              | <b>Point</b> | <b>Daily</b> | <b>Weekly</b> | <b>Annually</b> |
|-------------------------------|--------------|--------------|---------------|-----------------|
| Ash removing                  | 10           | 1×           |               |                 |
| Space around ash tray         | 11           |              | 1×            |                 |
| Space under exchanger         | 15           |              | 1×            |                 |
| Lever of turbulators          | 12           | 5–6×         |               |                 |
| Flap                          | 19           |              | 1×            |                 |
| Space of ventilator           | 21           |              |               | 1×              |
| Radial impeller of ventilator | 22           |              |               | 1×              |

\* Minimal recommended cleaning intervals. According to intensity of heating they can be also shorter.

## Information about processing of personal data

Dear Customer,

You provide us your personal information by completing and sending the Boiler start-up record and our company becomes your personal data manager in relation to you.

We hereby would like to inform you why and how we process your personal information, how we collect your personal information, for what purpose we handle it and the legal basis of such processing, how we handle personal data and what your rights are in relation to processing your personal data.

Please read the following information carefully before providing us your personal details.

In case of any questions related to the processing of your personal data, please do not hesitate to contact us at tel. no. +421 43 400 3103 or [gdpr@attack.sk](mailto:gdpr@attack.sk).

### Privacy Manager:

**ATTACK, s. r. o.**, with its registered office at Dielenská Kružná 5020, 038 61 Vrútky,

Slovak Republic

Tel.: +421 43 4003 103

E-mail: [exporten@attack.sk](mailto:exporten@attack.sk)

Web: <https://www.attack.sk>

### Processing of personal data

We will only process the personal information you provide to us in the Boiler start-up record, i.e.:

- Name
- Surname
- Address
- Phone
- Type and serial number of the product

### Purpose and legal basis for the processing of your personal data

We will process your personal data for the following purposes and on the basis of the following legal bases.

- 1) For the purposes of direct marketing, which is a legitimate interest of our company. The legal basis here is Art. Article 6 1. Letter. (f) Regulation (EU) 2016/679 of the European Parliament and of the Council of 27 April 2016 on the protection of natural persons with regard to the processing of personal data and on the free movement of such data, and repealing Directive 95/46/EC (General Data Protection Regulation).

The processing based on our legitimate interest, i.e. direct marketing, is following:

Your personal data will be stored in our electronic database which is managed directly and only by us. This electronic database is stored and secured on the property of our company. Your personal data will be used by our legitimate interest only in order to be able to send you an offer of our new products, especially in the event of the end of the expected life of product which you enter your personal data in the Boiler start-up record in if our company develops a newer and more technologically superior and better product that could replace the product in which you enter your personal data into the in the Boiler start-up record.

Direct marketing is our legitimate interest and the one of two purposes of processing of

- your personal data, i. e. direct offer of our products sent to you.
- 2) The legal basis for fulfilling the extended warranty agreement on the product in which you enter the Boiler Startup Record where your personal data is Art. Article 6 1. Letter. (f) Regulation (EU) 2016/679 of the European Parliament and of the Council of 27 April 2016 on the protection of natural persons with regard to the processing of personal data and on the free movement of such data, and repealing Directive 95/46/EC (General Data Protection Regulation).

This processing that is required to meet the extended warranty agreement for a product you are one of the parties will be following:

Our company provides you with an extended contractual warranty (beyond the statutory warranty) in such situation that you comply with the warranty conditions (see the warranty conditions in the Instruction for use, in which there is the Boiler start-up record with your personal data). In order to provide you with this extended contractual warranty we need to know who is the other party and whether you are performing your obligations under this agreement especially the mandatory annual service inspections. Therefore we need you to send us a record of this inspection after each annual inspection (max. 5 inspections) and we will declare in our database that you fulfill the terms of the contractual guarantee.

Since each contract has at least two contracting parties we need your personal data to identify you as a party and identify a specific product for the purposes of fulfilling the extended warranty agreement. We would not be able to fulfill our obligations under the extended warranty agreement properly without these data.

Our legitimate interest and one of the two purposes of processing your personal data is therefore the fulfillment of the contract, that is, the fulfillment of the contract for extension of the contractual guarantee.

Processing of personal data for both purposes is done manually and also in electronic information systems. However these systems are subject to rigorous and constant physical and technical control. All persons who, on the basis of our instructions and our credentials, come in contact with personal data in the framework of their work or contractual obligations are bound by confidentiality.

### **Category of recipients of personal data**

We process your personal data primarily by ourselves. However it may happen that we will have to use the services of another entity to process personal data for any of the above mentioned purposes. In this case the relationship between us and the third party will be the relationship between the administrator and the processor and we will make an agreement with this processor about the processing of the personal data in order to guarantee the security and legality of processing your personal data.

Your personal data may therefore be sold to the recipient of the following categories:

- a) A company that distributes our products in the territory of a member state of the European Union in which you have purchased a product which you enter your personal data in the Boiler start-up record in or in which such a product is put into service on your request
- b) A company providing bulk mailing services

### **The length of time the personal data will be stored**

We will process your personal data for at least the duration of the contractual warranty (i.e. for 5 years) for the purposes of fulfilling the warranty agreement and at most for the time of assumed lifetime of the products for which the Boiler start-up record for the purposes of direct marketing.

### **Raising objections to processing of personal data**

Whenever you have the right to object to our processing of your data for direct marketing purposes (see Purpose and legal basis for processing your personal data, item 1) above). If you have an objection to our processing of your direct marketing data, by the date of your objection will cease our processing your personal data for direct marketing purposes.

The objection to the processing of your personal data for direct marketing purposes can be sent to us by post to:

ATTACK, s. r. o., Dielenská Kružná 5020, 038 61 Vrútky, Slovak Republic. In the objection, it is sufficient to provide the name, address and the text "I hereby raise an objection to the processing of my personal data for the purposes of direct marketing" and your signature. We always inform you about the accepting your request without delay.

Please note that the right to object can not be invoked against our processing of your personal data necessary for the purpose of fulfilling the extended warranty agreement.

### **Your other rights related to the processing of personal data**

Please note that you also have the following rights in relation to our processing of your personal information:

- to ask for information about what personal data is processed by us,
- to request access to these data and let them update or fix,
- to require the deletion of these personal data, or the limitation of their processing,
- to raise objection to the processing of your personal data,
- the right to the portability of your personal data,
- in case of doubt regarding compliance with the obligations related to the processing of your personal data, contact the Administrator or the Office for Personal Data Protection.

You may enforce these rights to our company by the same procedure as the right to raise objections to the processing of personal data.







## **HEAT TECHNOLOGY MANUFACTURER**

ATTACK, s.r.o. • Dielenská Kružná 5020, 038 61 Vrútky • Slovakia

Tel: +421 43 4003 101 • E-mail: kotle@attack.sk

Export – tel: +421 43 4003 115 • E-mail: export@attack.sk



*All provided information is temporary, subject to change without notice and for informational purposes only. Variations in product visual display are possible and may not match the offer and range of equipment for different markets. ATTACK s.r.o. reserves the right to make changes to specifications and content without prior notice. Pictures and product specifications are only informative. Price and offer changes are reserved.*