

# *Installation/Operator's Manual*



## Installation

To insure optimum performance and safe operations please follow the detailed information provided with each furnace. We require that a licensed, bonded heating contractor install the unit and that a permit be obtained for the unit installation.



Listed

---

PINNACLE STOVE SALES INC.  
1089 HIGHWAY 97 NORTH  
QUESNEL, BC. V2J 2Y3  
TEL. (250) 992-5050  
FAX. (250) 992-5850

---

**GBU070  
PELLET/CORN  
FURNACE**



# TABLE OF CONTENTS

FURNACE SPECIFICATIONS	pg 2
CONTROL AND COMPONENT FUNCTIONS	pg 3
GENERAL INSTRUCTIONS	pg 4-5
CLEARANCE TO COMBUSTIBLES (diagram)	pg 6
CHIMNEY AND VENTING	pg 7
VERTICAL CHIMNEYS	pg 8
DUCTING - PRIMARY FURNACE	pg 9
ELECTRICAL REQUIREMENTS	pg 10
THERMOSTAT INSTALLATION	pg 10
TURNING OFF THE UNIT	pg 11
MAINTENANCE	pg 11
BURNING CORN	pg 12
WIRING DIAGRAM	pg 13
START UP INSTRUCTIONS PELLET	pg 14
START UP INSTRUCTIONS CORN	pg 15
PRIMARY CONTROL SEQUENCE OF OPERATION OII 350S	pg 16
TROUBLE SHOOTING	pg 17-26
PARTS LIST	pg 27
WARRANTY	pg 28

## FURNACE SPECIFICATIONS

HEIGHT-----	45 ¼
WIDTH-----	24 ¼
DEPTH-----	33 ½
WEIGHT-----	385 lbs
VOLTS-----	110 V
FLUE SIZE-----	4" Pellet Vent
BREACH-----	Rear
HOPPER CAPACITY-----	80 lbs
BTU – INPUT-----	70,000 BTU/HR
OVERALL UNIT EFFICIENCY-----	80%
WARM AIR OUTLET SIZE-----	12" X 12"
BLOWER-----	¼ hp, 1250 CFM
COLD AIR RETURN/FILTER SIZE-----	15" X 24"

## CONTROL AND COMPONENT FUNCTIONS

AUGER The auger transfers the pellet fuel from the hopper end of the burner tube down and into the fire pot.

AUGER MOTOR The auger drive motor turns the auger.

BURNER TUBE The burner tube contains two passageways, one for the auger tube and the other for combustion air. This tube supplies both the fuel and combustion air to the fire pot.

BLOWER The blower forces return air over the furnace heat exchanger and into the home's duct system. The blower is controlled by the fan limit control.

CUP MOTOR The cup drive motor turns the cup which dispenses fuel from the pellet hopper to the auger.

DRAFT INDUCER The draft inducer takes combustion air, forces it down the burner tube and into the fire pot where combustion occurs. The flame can be adjusted by regulating the damper on the draft inducer.

FAN LIMIT CONTROL The fan limit control automatically activates the blower on temperature rise, and disengages on temperature fall. Normally, this control is set to bring the blower on at 140°F and then turn off at 100°F. The fan limit control also features a 200°F limit, where if the temperature for whatever reason may climb to 200°F this control cuts power to burner, but keeps the blower running to cool the heat exchanger. **NOTE: IF YOU ARE REPLACING THE FAN LIMIT CONTROL, MAKE SURE THE BRASS CONNECTOR IN THE MIDDLE IS SNIPPED OR REMOVED, IF IT IS NOT IT WILL RUN CONTINUOUSLY.**

FIREPOT The fire pot is where combustion occurs. Pellets are delivered into the fire pot by the auger. The heat of the fire in the fire pot causes gases to oxidize off the pellets, and as the combustion air mixes with these gases, they burn with a flame similar to that of an oil or gas fire.

HOPPER The hopper is where the pellets are stored and then funnelled down to feed the cup.

SAFETY DISC The safety disc interacts with the burner for positive flame protection to guard against misfires and to shut down the burner in the event of the fuel hopper running dry. If the burner loses its flame potential, misfires, or runs out of fuel, the safety disc will drop out, locking out the burner.

BURNER LIMIT If the unit should ever burn back into the burner tube, the 200°F limit will open the circuit, shutting the entire burner down. The burner will not start until it is manually reset. If this should happen, locate the cause before resetting limit and relighting unit.

## GENERAL INSTRUCTIONS

1. Installation is allowed only by a licensed, bonded heating contractor.
2. Install this furnace in accordance with local mechanical codes and regulations.
3. Consult manual "J" of the air conditioning contractors Association (ACCA) or air 230 to estimate heating requirements.
4. Always install this furnace with adequate return and supply duct systems.
5. The installer must explain in detail, the operations of this furnace to owner/operator, including minor service requirements.
6. Never block or restrict any air intake ports. Dangerous overheating can result.
7. Install this furnace with safe clearances to combustible surfaces.
8. Connect this furnace to its own independent Class L Chimney at least 4 inches in diameter.
9. This is a good furnace, but it cannot make up for a poor or incorrect installation.
10. Repair should be done only by a qualified service person.
11. Never stack or pile combustible materials against the furnace.
12. Never use, store or dispose of flammable liquids near the furnace.
13. Always have a smoke or ionization detector installed in your home.
14. **Disclaimer notice:** No guarantee is made regarding the heating capacity of this unit. The actual area that this unit will heat depends on factors such as conditions of the building, heat loss, type of construction, the amount of insulation, type of air movement, and the location of the furnace.
15. The manufacturer accepts no responsibility for improper installation of this pellet/corn furnace or improper use or negligence of any kind with continued use of the furnace.
16. The manufacturer recommends fuelling this furnace with premium wood based pelletized fuel with moisture content between 2 – 8% or clean-shelled corn with a moisture content less than 15%. Do not attempt to burn higher moisture content or burn lesser grade fuels. Any questions regarding pellet fuel can be answered at the Pellet Fuels Institute website, [www.pelletheat.org](http://www.pelletheat.org).
17. If this furnace runs out of fuel, or misfires, it will automatically shut-off. If this occurs, you must manually re-light the corn unit, repeating steps 8 – 14 in the start up instructions on page 15. Re-light the pellet unit according to operating instructions on page 14.
18. Do not operate this furnace with door open.

19. Doors and heat exchanger surfaces of the furnace are hot during operation. DO NOT touch with bare hands, or allow children to play near the furnace unattended.
20. Do not allow anyone to operate the furnace that is not familiar with its operation.
21. Manually place fuel in the fire pot ONLY when starting a fire in a cold furnace. Never add pellets by hand to a smouldering fire or a hot fire pot. DANGEROUS smoking could result.
22. After lighting, make sure the main fire door and ash door are closed and sealed tight.
23. Set combustion air damper at not less than 50%. Damper settings will vary widely depending on draft characteristics of your chimney system. The unit should emit no visible smoke from the exhaust, if it does, open the damper slide until smoke is gone. Draft characteristics should be between .04 and .08 inches water.

# CLEARANCE TO COMBUSTIBLES

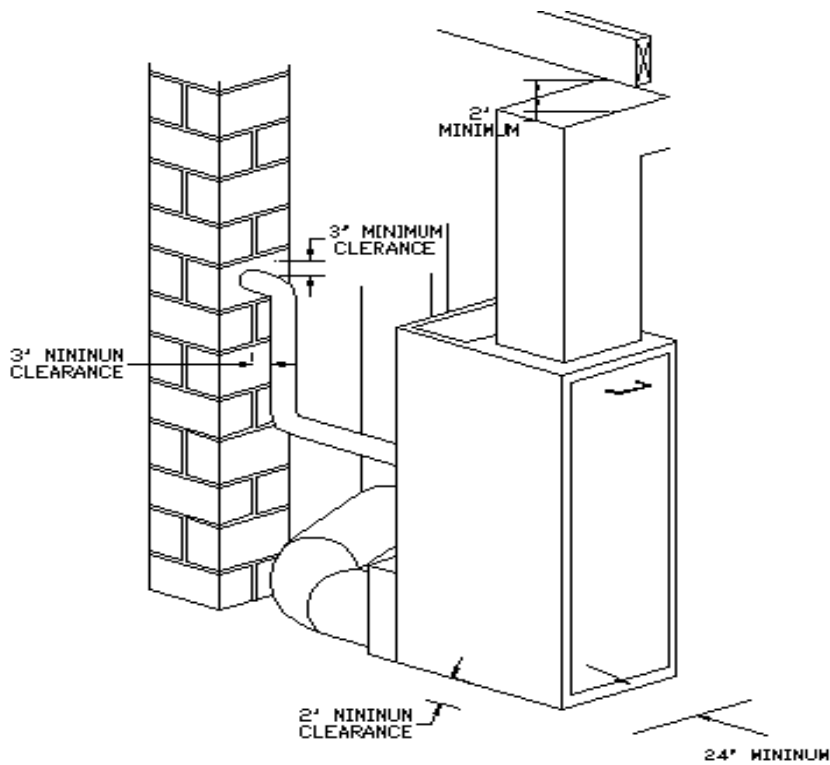
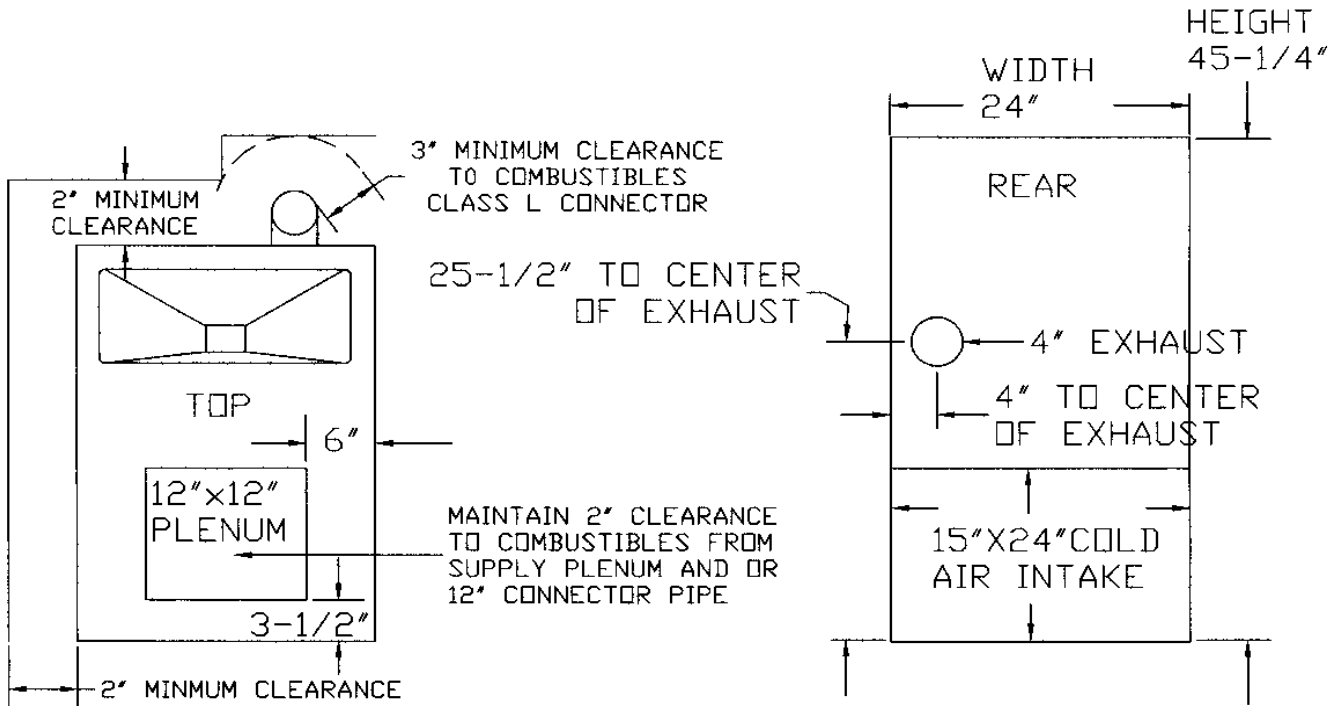

## CHIMNEY AND VENTING

**Chimney required for the GBU070 is 4" Class "L" (also known as PL vent). A starting collar must be used to attach the venting system to the furnace. When connecting into a Class "A" or masonry chimney an approved 4" liner MUST be used to prevent back drafting of the chimney.**

### **EXISTING CLASS "A" CHIMNEY:**

Run 4" Class "L" connector from the furnace connection to a positive connection with the class "A" chimney. **AN APPROVED 4" LINER MUST BE USED IN CLASS "A" CHIMNEYS.** Make sure each joint is firmly locked in place. Make sure the attachment of Class "L" to the Class "A" chimney is secure with sheet metal screws. Seal all joints with high temperature silicone. Class "L" connector should maintain a pitch on rise from the furnace to the chimney of at least 1/4" per foot.

A): "L" Vent connector 4"                      B): "L" Vent elbow 90° adj. 4"

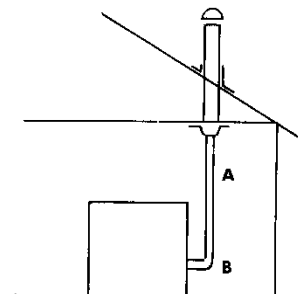

**EXISTING MASONRY CHIMNEY:** Run 4" Class "L" connector from the furnace connection to a positive connection with the masonry chimney. Make sure each joint is firmly locked in place. Make sure the penetration of the Class "L" connector into the masonry chimney is sound and secured with high temperature cement. Seal all joints with high temperature silicone. Class "L" connector should maintain a pitch on rise from the furnace to the chimney of at least 1/4" per foot.

### **AN APPROVED 4" LINER MUST BE USED IN MASONRY CHIMNEYS.**

Your new furnace is so efficient; an unlined chimney could remain cold and cause a downward pressure creating poor burning, incomplete combustion or back draft.

A.) "L" Vent connector 4"                      B.) "L" Vent elbow 90° adj. 4"

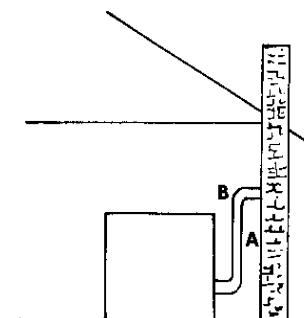

**NEW VERTICAL INSTALLATIONS:** Install 4" Class "L" chimney add accessories according to manufacturers instructions and local codes (3" clearance to combustibles). Run Class "L" chimney all the way from the furnace connection to point of termination. Make sure each joint is firmly locked in place. Seal all joints with high temperature silicone. Class "L" connector should maintain a pitch on rise from the furnace to the chimney of at least 1/4" per foot.

A.) Vertical top 4"                                      D.) Adj. flashing 4"  
 B.) "L" Vent pipe 4"                                E.) Fire stop spacer 4"  
 C.) Storm Collar 4"                                F.) "L" Vent 90° adj. 4" clean out tee

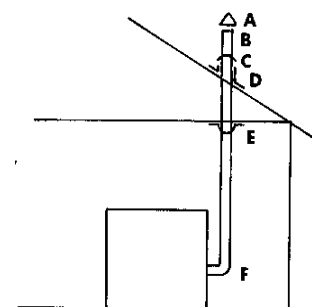

**DIRECT VENT HORIZONTAL TERMINATION IS NOT RECOMMENDED**



## VERTICAL CHIMNEY'S

The chimney that this unit is connected to (Class "L", all fuel or masonry) should extend above the roofline of adjacent buildings to prevent downdraft situations.

1. Class "L" connectors shall be installed without any downward pitch from the appliances and without any dips or sags.
2. Class "L" connectors shall be pitched upward from the appliance at least  $\frac{1}{4}$ " per foot.
3. Class "L" starter adapter shall be firmly attached to the vent outlet collar of the furnace and a positive seal made with high temp silicone, approved metal tape and/or sheet metal screws.
4. The chimney shall extend at least three (3) feet above the highest point when they pass through the roof of the building and at least two (2) feet higher than any portion of any building within ten (10) feet.

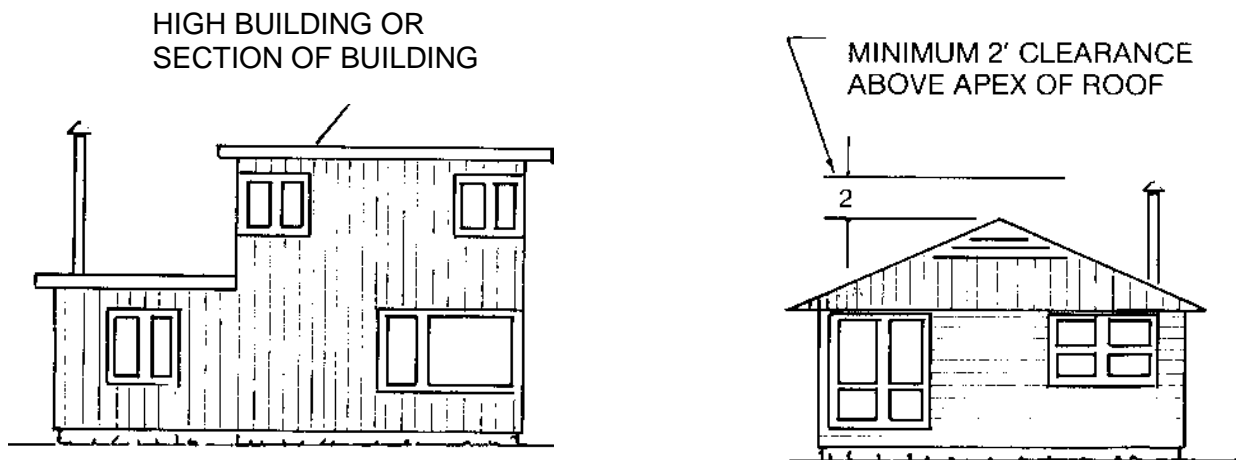

### COMBUSTION AIR:

Furnaces must have air (oxygen) for proper performance. The incomplete combustion that takes place when a furnace is "air starved" causes carbon monoxide (CO) to be formed in quantities that can be dangerous inside a well-sealed house. Having a source of combustion air from outside prevents this "air starvation" of the furnace. Provisions for combustion air shall be made in accordance with applicable provisions of local building codes. The GBU070 combustion air intake is the slot on the back of the unit. Keep this opening free of obstructions which would restrict airflow.

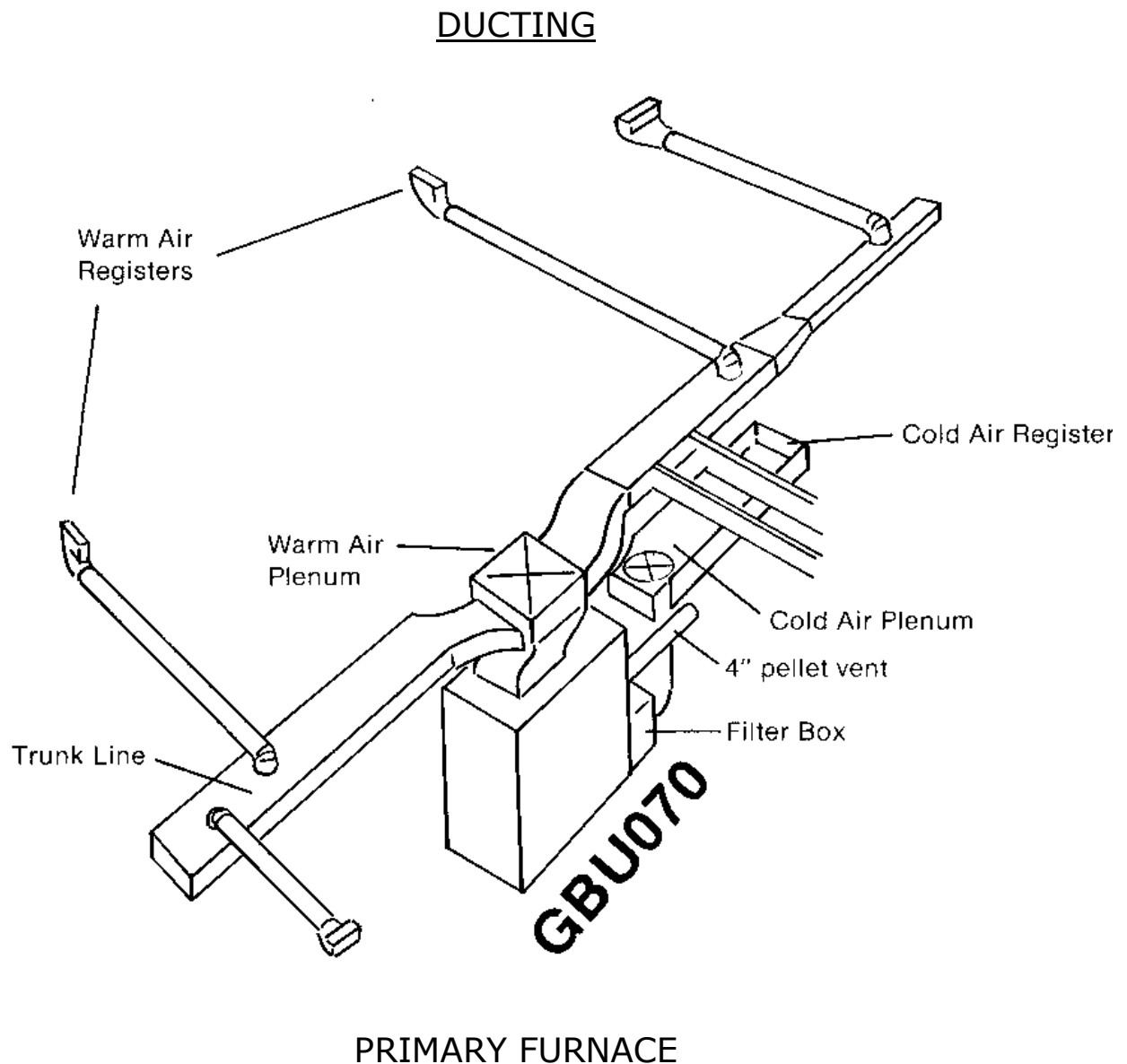

To install the GBU070 as a "Primary Furnace" first locate the furnace as near the chimney and as centralized with respect to heat distribution as practical. Follow all clearance to combustibles requirements. Connect the ductwork to the furnace. Minimum supply plenum size: 14" x 14", minimum return plenum size: 12" round. When a furnace is installed so that supply ducts carry air circulated by the furnace to the areas outside the space containing the furnace, the return air must also be handled by a duct sealed to the furnace casing and terminating outside the space containing the furnace. Where there is no complete return duct system, the return connection must be run full size to a point outside the furnace room. Air duct systems should be installed in accordance with standards for air conditioning systems. NFPA Pamphlet #90. They should be sized in accordance with ACCA Manual D or whichever is applicable, after completing installation as per the appropriate section of this manual.

## ELECTRICAL REQUIREMENTS

1. Make sure that the power source conforms to the requirements of the furnace. Disconnect the power source before performing any maintenance or electrical work.
2. Connect the electrical power according to the appropriate wiring diagram on the following page.
3. Plug the power supply into a surge protected and grounded 15-amp branch circuit. The outlet must have the correct polarity. With a voltage tester, check the outlet and make sure you have a minimum 115 volts and that the branch circuit is not overloaded with too many appliances. A surge protector must be used to have electrical items warranted.

## THERMOSTAT INSTALLATION THERMOSTAT IS SUPPLIED WITH UNIT

1. Install the thermostat in a central location. A low voltage 2-wire thermostat should be used and installed according to manufacturers directions supplied with the thermostat.
2. Run the thermostat wire (18/2 wire).
3. For best operation, mount the thermostat on a draft-free inside wall, if it must be installed on an exterior wall; insulate the backside of the mounting plate.
4. See wiring diagrams for thermostat terminal locations. Leads for thermostat wire connection off the primary control are yellow.
5. A programmable thermostat may be used but must be a 2-wire, low voltage type as only 9 volts is switched, by the yellow wires on the primary control.

## TURNING OFF THE UNIT

Turn the power switch to draft fan. Fuel will stop feeding but the draft fan will remain running. Let run until fire burns out completely. Set power switch to off.

NOTE: Approximately 10 – 12 minutes should be enough time for fire to burn out. Time will vary depending on fuel type.

## MAINTENANCE

1. Check the ash pan regularly and empty as necessary. Dispose of the ashes in a metal container, and when cooled, bury them to prevent any spontaneous fires.
2. Check the fire pot regularly for any residue build-up. Clean and dispose of them when completely cooled.
3. Remove the two heat exchanger access panels twice per burning season and check the heat exchanger for ash. Vacuum if necessary. Replace gasket material if any tearing or deterioration occurs.
4. Annually check the blowers for lint deposits from carpeting, dryer lint, furniture coverings, pet hair, etc.
5. Inspect the flue pipe or vent assembly and chimney each time the heat exchanger is serviced (minimum twice per heating season). Clean these passages as needed. Higher usage of the unit could require more frequent cleanings.
6. Your unit is equipped with an aluminium air filter, wash and clean it regularly. At least once a month.

## BURNING CORN IN THE GBU070

**NOTE:** If your 070 was purchased as a corn unit the corn pot should already be installed. The corn pot utilizes a lift out cast iron inner liner that removes for easy cleaning. A rod will also be provided to lift the pot out of the furnace.

1. Your GBU070 will burn most types of clean-shelled corn. It is not necessary to mix corn with wood pellets although some people have had better success burning a 50/50 mix.
2. Typically, burning corn requires a bit more combustion air than wood pellets. The shutter on the draft inducer should be initially set at 50% open, the cycle time at 8 minutes and the pilot draft switch on the primary control at medium.
3. We don't recommend direct venting when corn is the primary fuel. For corn burning, the GBU070 needs a natural draft and this can only come from a vertical chimney. We do recommend stainless chimney be used when corn is the fuel. Corn, by nature, is more acidic than pellets and can eat away steel or galvanized chimney.
4. The moisture content of the corn should be 15% or less, and care should be taken to ensure that there are no foreign objects in the corn (i.e.: sticks, stalks, cob pieces) which will jam the feed system.
5. We recommend starting a corn fire with wood pellets as corn has a dense shell that can be difficult to start. Place 1" of coarse oyster shell in the bottom of the pot before using. Use a non-volatile approved fire starter to light the pellets.
6. Corn has more BTU's than wood pellets, about 1,000 BTU's per pound more. Thus the furnace may have to be metered down to prevent over firing.
7. **IT MAY SERIOUSLY DAMAGE YOUR POT.** If you have a spare pot you can let the used pot sit in the air for 2-3 days, the clinker will absorb moisture from the air and become powdery, then dump the residue out. **DO NOT USE ANY OBJECT TO POUND OUT THE CLINKER. THIS WILL DAMAGE YOUR POT.**
8. **THERE IS NO WARRANTY ON BURN POTS.** When burning corn the primary combustion takes place on a fluidized bed at the bottom of the fire pot. A white calcium-like deposit (clinker) will be present in the fire pot. This deposit needs to be removed so that proper combustion can be maintained. Under heavy usage it may be necessary to remove the clinker daily. Stir the pot with a metal stirrer and flick out any clinker you find into the ash pan. A bit of oyster shell will be removed with the clinker. When all the oyster shell has been removed, about 300 – 400 lbs of corn (approx 4 – 6 days) has been burned, remove pot for a thorough cleaning and replace with spare pot, or clean and replace used pot.
9. **We recommend purchasing an extra pot to make cleaning easier and generate less wear on your pot.**
10. Turn the switch on the primary control to the draft fan position, this will allow the remaining fuel to be burnt up and help cool down the fire pot.

11. Let the pot cool **completely** to the touch and place into a bucket of water to dissolve the clinker. **DO NOT PLACE HOT POT IN WATER;**

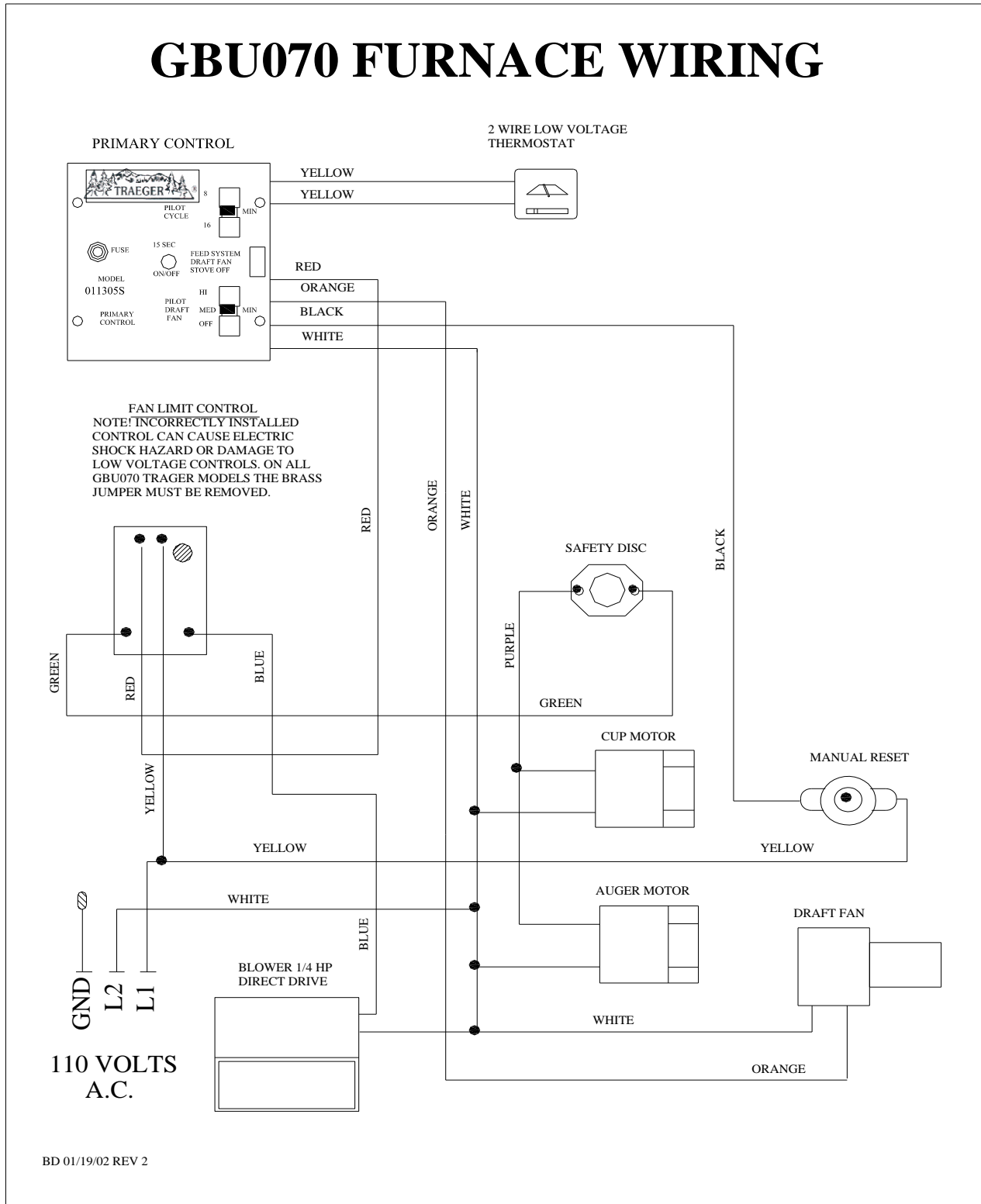

## START UP INSTRUCTIONS – PELLET

Now that your furnace has been properly installed, it's time to fire it up!

1. Plug in the furnace. NOTE: Make sure you plug into a properly grounded, surge-protected outlet that has proper polarity so as not to damage the circuitry of the control board.
2. Remove the rear panel of the furnace. Push in the white summer fan button located in the right side of unit in silver box, thus starting the blower. When blower starts and is running smoothly, pull the summer fan button back out to stop the blower.
3. Check the damper on the draft inducer making sure that it is set at 50% open. On the primary control board, set the cycle time to eight (8) minutes and the pilot draft switch to medium.
4. Set the remote thermostat to 90°F.
5. Turn the power switch to Draft Fan. The draft fan should now come up to full speed. Look down the hopper to make sure nothing is obstructing the cup. Open the front panel to get access to the fire pot door. Open the fire pot door and place your hand over the fire pot and see if the draft inducer is forcing air into the fire pot. Turn the power switch back to off.
6. Load the hopper with pellets.
7. Place approximately 2 full cups of pellets in the bottom of the fire pot. Apply non-volatile lighting material such as gel alcohol or other pellet appliance approved lighter. Light fire. NOTE: **NEVER** use charcoal lighter or kerosene to light the pellets.
8. Let burn for 5 minutes. Securely close fire pot door. Replace front panel of furnace.
9. Turn power switch for Feed System. The draft fan will come up to high and the flame will increase. Keep the thermostat turned to 90°F for approximately eight (8) minutes. A solid flame will need to be established before the burner will remain locked in. Then set your thermostat to the desired temperature.
10. Your furnace should continue to heat up until the blower comes on thus moving heat through the ductwork.
11. After 10 minutes, if the fire in the burn pot has gone out, let the fire go out completely and start from step 7 again.
12. The furnace will emit smoke and fumes for a few minutes from the paint curing on the initial fire up. Provide adequate ventilation when this occurs.
13. Sit back and enjoy the heat from your Traeger Furnace.

## START UP INSTRUCTIONS – CORN

NOTE: Pellets are required to start your initial fire.

14. Plug in the furnace. NOTE: Make sure you plug into a properly grounded, surge-protected outlet that has proper polarity so as not to damage the circuitry of the control board.
15. Remove the rear panel of the furnace. Push in the white summer fan button located in the right side of unit in silver box, thus starting the blower. When blower starts and is running smoothly, pull the summer fan button back out to stop the blower.
16. Check the damper on the draft inducer. It should be set at no less than 50% open.
17. On the primary control board, set the cycle time to eight (8) minutes and the pilot draft switch to medium. If more combustion air is needed, adjust the damper on the draft inducer in small increments.
18. Set the remote thermostat at 90°F.
19. Turn the power switch to Draft Fan. The draft fan should now come up to full speed. Open the fire pot door and place your hand and feel if the draft inducer is forcing air into the fire pot. Turn the power switch back to off.
20. Check the hopper to insure that nothing is obstructing the feed cup. Load the hopper with corn.
21. Place a 1" of oyster shell and approximately 2 full cups of pellets in the bottom of the fire pot. Apply non-volatile lighting material such as gel alcohol or other pellet appliance approved lighter. Light fire. NOTE: **NEVER** use charcoal lighter or kerosene to light the pellets.
22. Let fire burn for approximately five (5) minutes. Then securely close fire pot door.
23. Turn power switch for Feed System. The draft fan will come up to high and the fire will increase. Keep the thermostat turned to 90°F for approximately ten (10) minutes. A solid fire will need to be established before the burner will lock in and start feeding corn.
24. Set your thermostat to desired temperature. Your furnace should continue to heat up until the blower comes on. Heat will be distributed out of the unit.
25. If after ten (10) minutes your fire is not established, let the fire go out completely and start from step 8 again.
26. The furnace will emit smoke and fumes for a few minutes from the paint curing on the initial fire up. Provide ventilation when this occurs.
27. Set your thermostat at your desired level, set back and enjoy the heat from your Traeger Furnace.



# PRIMARY CONTROL OII 350S SEQUENCE OF OPERATION

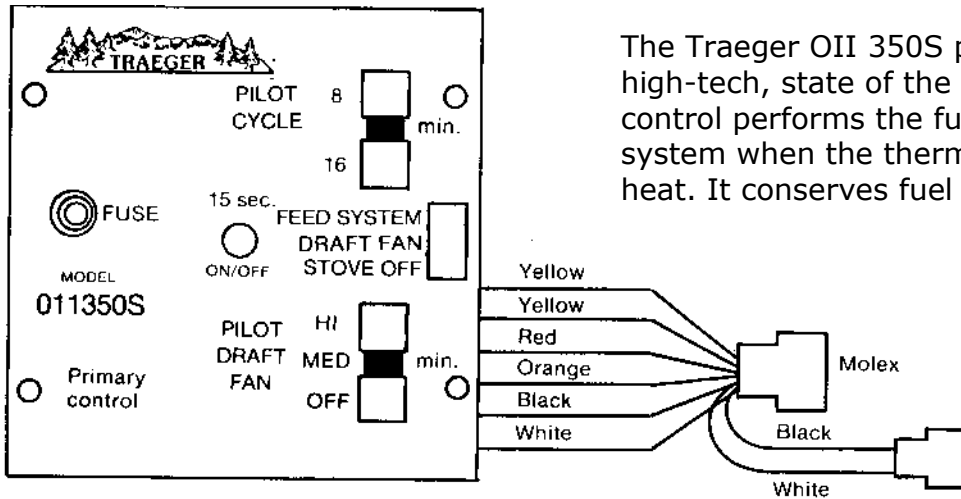

The Traeger OII 350S primary control is a high-tech, state of the art computer. The control performs the function of piloting the system when the thermostat does not call for heat. It conserves fuel consumption.

## FUSE

The computer board is protected by a 3-amp fuse. There are many manufacturers of this fuse. Fuses are readily available at your local hardware or auto parts store. i.e. Napa Balkamp #782-1046 AGC 3.

## RED LIGHT INDICATOR

When the wall thermostat circuit is closed, and calling for heat, the light indicator will remain dim as long as the circuit is closed. When the thermostat is open (not calling for heat) the light will blink from bright to dim every 15 seconds as part of the counting procedure.

## ON TIME (2MINUTES)

The On Time controls the amount of time the burner stays active (fuel is fed). It operates in conjunction with the cycle time and is pre-set in the control at 2 minutes

## PILOT CYCLE TIME SWITCH

The cycle time switch controls the total cycle both on and off, 8 or 16 minutes.

## COMBINATION FUNCTION OF ON TIME AND CYCLE

The On Time is subtracted by the Cycle Time  
Example: With the On Time pre-set at 2 minutes and the Cycle Time set at 16 minutes, the unit would come on (feed corn) for 2 minutes and not feed corn for 14 minutes. This gives you a complete cycle time of 16 minutes.

## WIRING

The OII350S primary control has 6 lead wires. A wiring colour code is provided on back of each control. Black is line power. White is neutral. Red is load and feeds the auger motor and cup motor. Orange feeds the draft inducer. 2 yellows go to the wall thermostat.

## POWER SWITCH

Cuts power to burner but not blower fan system. Used to shut furnace down.

## PILOT DRAFT SWITCH

Controls the speed of the draft inducer on pilot or idle mode. Normally set on Medium, but will vary with differing chimney configurations.



## TROUBLE SHOOTING GUIDE

### **Tools Essential for Trouble Shooting**

1. Furnace Installation and Operation manual
2. Circuit Tester / Volt Meter
3. Molex pin Extractor
4. Volt Meter

### **ATTENTION: Before attempting any trouble shooting:**

1. Check your outlet (for 070) or your wiring to breaker box (130 & 150) to insure proper polarity and grounding.
2. Check flue for any blockage.
3. Take time to clean burn pot and heat exchangers.
4. If you have replaced the fan limit control, make sure the brass connector in the middle has been removed or snipped.

### **STEP #1**

#### **CIRCULATING BLOWER CHECK**

NOTE: The factory setting for the blower is to come on at 150°F and off at 100°.

Find the blower limit control; it is a silver part with the Honeywell trade line label. It will have a white button. Pull the switch to the on position.

Should the blower fail to come one the first step is to check the power source. If the power source is OK you will need to make sure that all wire leads are properly connected. If the blower still fails to run, replacement will be necessary.

### **STEP #2**

#### **CONFIRM POWER TO CONTROL BOARD**

Turn Main power switch from the "Stove Off" position to the "Draft Fan" position. If the red indicator light comes on, there is power to the control board. If the light does not come on check the following:

- A. Power Source (See Step #1)
- B. Fuse
- C. Burner Manual Reset – If the fuse is not blown and the reset button has not popped out, inspect the molex connection. Finally, using a voltmeter, check for power at the power switch. If the meter indicates 100v and the light still doesn't come on, replace the control board.

### **STEP 3# CONFIRM DRAFT FAN OPERATION**

Be sure the main power switch is in the "Draft Fan" position. This will cause the draft fan to operate at full power (110v). The draft fan will operate at 70 – 75v when pilot draft switch is set at high. It will receive 60 – 65v in the medium position and zero volts in the off position when furnace is not feeding fuel. You should be able to hear the draft fan come to

full speed. You can check movement of air by placing you hand over the fire pot. If movement of air is not obvious, make sure that the shutter is open.

### **STEP #4 INSPECT FUEL METERING CUP FOR BLOCKAGE**

To inspect the metering cup, first you will need to empty the hopper. Reach down through the hopper and rock the cup back and forth. The cup should mover ¼ of an inch. If it does not move, something is jamming it. Sometimes the obstruction can be removed by rotating the blade on the cup motor counter clockwise. If this doesn't work you will have to remove the cup motor and cup to remove the blockage.

### **STEP #5 CONFIRM CUP AND AUGER MOTOR OPERATION**

Place a jumper wire between the leads to the safety disc located on the exhaust flange. Set the main power switch to "feed system". Both the cup and auger motor should start now. If the motors run but the fuel metering cup and/or auger do not turn, check the cast iron couplers to make certain that the set screw is tight or that a coupler has not snapped off. NOTE: Anytime you are checking the motors, you should verify the speed at which motors are turning. This can be accomplished by timing the revolution of the coupler. Using the setscrew as a reference the bottom motor (Auger) will make one revolution in 10 seconds. The top motor (cup) will make approximately one revolution every 45 seconds. Remove jumper wire and plug wire leads back to safety disc.

### **STEP #6 RELIGHT THE FURNACE**

Use normal start up procedure to start the furnace.

## INSTALLATION/ADJUSTMENT RELATED PROBLEMS

PROBLEM: **Incomplete combustion, unburned fuel.**

SOLUTION: 1. Adjust air shutter to a more open position.  
2. Make sure of correct chimney, is chimney drafting?  
Is the chimney direct vented? Is it a tight basement?  
Outside air may be needed. What is fuel moisture?

PROBLEM: **Burns fuel too quickly and may have difficulty holding a fire on pilot.**

SOLUTION: Adjust air shutter to a more closed position. If that doesn't solve the problem, check for an over drafting chimney by using a draft gauge. To solve over drafting use the following procedures:

**Masonry Chimney:** Cover top with a plate and mount a 4" cap. If that doesn't slow it down, use a barometric damper.

**Pellet Vent:** Install a barometric damper.

PROBLEM: **Smoking**

SOLUTION: Make sure that the chimney is not direct vented on a windy side of the house. Also check gaskets to insure proper sealing. Adjust damper opening, might be too far closed.  
Is heat exchanger clean? Is chimney clean?

PROBLEM: **Auger squeaks**

SOLUTION: Adjust pillow block bearing by loosening screws on each side. Let auger run for one minute. Tighten screws. Auger should realign itself. Possible build up of carbon on end of auger where it enters burnpot.

PROBLEM: **Decrease in heat output**

SOLUTION: Thoroughly clean heat exchanger. Did you start using different fuel? Shutter on draft fan moved?

## OPERATOR RELATED PROBLEMS

PROBLEM: **Feed system does not lock in.**

SOLUTION: Repeat start up using more fuel.

PROBLEM: **Furnace will not start up after power outage.**

SOLUTION: Depress blower manual reset.

## **OPERATOR RELATED PROBLEMS cont'd**

**PROBLEM: Furnace will not feed fuel.**

**SOLUTION:** Check for blockage in metering cup.  
Is there fuel in the hopper?

## **FUEL RELATED PROBLEMS**

### **Symptoms of Poor Fuel:**

1. Unburned pellets
2. Fire pot overflows as a result of high moisture content.
3. Lack of heat.
4. Excessive ash build-up.
5. Incorrect size.

## **PROBLEM**

### **NO HEAT**

# 1. Pellet fire has gone out during normal operation.

CHECK CAUSES: 1, 2, 3, 7, 8, 10, 11, 13, 14, 15, 17, 21, 23, 24, 25, 26, 28, 36, 42 or 45.

# 2. Blown fuse or circuit breaker.

CHECK CAUSES: 2, 3, 7, 8, 16, 17, 27, 43, 44 or 45.

# 3. Unit will not lock in on start up.

CHECK CAUSES: 2, 5, 10, 11, 15, 20, 21, 25 or 34.

# 4. Fire has gone out during turned down pilot time.

CHECK CAUSES: 1, 2, 5, 10, 11, 14, 15, 20, 21, 23, 24, 28, 39, 40 or 42.

### **PERFORMANCE DEFICIENCIES:**

# 5. Unit burns with a dirty lazy flame.

CHECK CAUSES: 5, 29, 36, 40, 59 or 60.

# 6. Furnace burns too many pellets.

CHECK CAUSES: 5, 14, 21, 28, 30, 31, 32, 53 or 59.

# 7. Shocked when touching furnace.

CHECK CAUSES: 16, 17, 44 or 45.

# 8. Furnace is up to temperature, but won't run on thermostat.

CHECK CAUSES: 13, 17, 18, 19, 23, 24 or 25.

# 9. Firepot is full of pellets when burning.

CHECK CAUSES: 5, 20, 29, 36, 37, 40, 53, 59 or 60.

#10. The blower cycles on and off too much.

CHECK CAUSES: 9, 12, 22 or 59.

#11. Furnace burns without regard to thermostat, overheats.

CHECK CAUSES: 4, 8, 13, 14, 18, 30, 31, 33 or 50

#12. Furnace doesn't make as much heat as it used to.

CHECK CAUSES: 5, 32, 37, 40, 53, 56, 57 or 59.

#13. Circulating blower will not run at all.

CHECK CAUSES: 9, 12, 17, 22, 45 or 56.

#14. Remote thermostat is not accurate by thermometer.

CHECK CAUSES: 18, 30, 31, 32, 33, 48 or 54.

#15. The circulating blower runs continually.

CHECK CAUSES: 9, 12, 38 or 53.

#16. The furnace will not heat the whole house.

CHECK CAUSES: 30 or 32.

## **UNDESIRABLE BY-PRODUCTS**

#17. Owner smells fumes in home.

CHECK CAUSES: 5, 6, 14, 20, 21, 29, 35, 36, 37, 40, 46, 49 or 58.

#18. Dust in the room and on the furniture.

CHECK CAUSES: 4, 6, 35, 41, 49 or 59.

#19. Large amounts of unburned pellets in ash pan.

CHECK CAUSES: 5, 20, 21, 29, 36, 37, 40, 53 or 57.

#20. Large amount of soft ash and hard clinkers in firepot.

CHECK CAUSES: 53.

#21. Furnace smokes out vent running on pilot or full burn.

CHECK CAUSES: 5, 13, 14, 20, 21, 28, 29, 34, 37, 39, 40 or 53.

#22. The Furnace makes too much noise.

CHECK CAUSES: 8, 22, 28, 36, 47, 51 or 55.

## **CAUSES**

1. The pellets in the hopper have tunnelled out or have bridged over.

Remedy: Check the fines content and or length of the pellets against the manufacturer's specifications.

2. An impurity in the pellets has hung up the cup.

Remedy: The cup is not turning and the motor is very hot. Unplug the stove, empty the hopper, dislodge the foreign object, check the cup operation and refuel.

3. An impurity in the pellets has hung up the auger.

Remedy: The cup is turning but the auger is not. Loosen the coupling on the auger and try to turn free. Do not force it. You may have to remove the auger to clear.

4. Fines and dust are accumulating in the burner compartment area.

Remedy: Check the seal between the hopper and the burner flanges as well as the hopper seam seals. Reseal.

5. The heat exchanger is full of ash.

Remedy: Shut the furnace off, let cool, remove all heat exchanger cover plates and vacuum out. Check vent system while you are at it.

6. The main fire door has been left ajar.

Remedy: Close the door completely and make sure it is secure.

7. Cup motor is defective.

Remedy: Unhook motor from drive coupling, give motor power and check for operation. Replace motor if defective.

8. Auger motor is defective.

Remedy: Unhook motor from drive coupling, give motor power and check for operation. Replace motor if defective.

9. Fan limit control is defective.

Remedy: Replace with new control.

10. Safety disc defective.

Remedy: The safety disc is normally open and closes on temperature rise. It must be up to temperature and lock in to allow the burner to run. If you are sure that it is not reacting to temperature, then you can test its defectiveness by bypassing from one terminal to another. If burner activates after bypassing, then replace safety disc.

11. Safety disc is set wrong.

Remedy: Reset the safety disc according to manufacturers recommended settings.

12. Fan limit control settings are off.

Remedy: The first peg is the fan off setting (at which temperature the blower will turn off), the second peg is the fan on setting (at which temperature the blower will turn on), the third peg is the limit setting (high temperature shut down). All reading left to right. Check the settings as per the manufacturers recommended settings.

13. Primary control is defective.

Remedy: Verify that this control is defective by tracing power during switching. Don't guess! If defective replace.

14. Primary control setting wrong.

Remedy: Check setting according to manufacturer's recommended settings. Remember that On time is amount of time burner will run during pilot burn, and Cycle time is the total cycle both on and off. To find the off time, subtract the on time from the cycle time. Reset and adjust draft setting accordingly.

15. Ash build up behind safety disc.

Remedy: Ash has accumulated behind the safety disc, thereby acting as an insulator on the safety disc sensing area. Clean the heat exchanger, particularly behind the safety disc.

16. Improper stove ground.

Remedy: Check the ground. Check the outlet. Just because there is a three-prong outlet receptacle does not mean that there is a ground wire hooked up to it, and then where does that ground wire go to? This appliance must be properly grounded. Also remember that the primary control grounds itself to the junction box, so never work on the unit with the primary control off the junction box with the power on.

17. Loose wiring connection.

Remedy: Check power location with tester. Trace power in to control function. Look for loose wires, wire nuts, terminals, and tighten. Make sure that the power is off when looking for loose wires.

18. Defective thermostat.

Remedy: Remove the thermostat from the wall, cross the two wires, if this activates the burner then replace the thermostat.

19. Break in thermostat wire.

Remedy: Go back to the wiring connection at the furnace where the thermostat wires tie in to the yellow primary control wires, disconnect the thermostat wires, cross the yellow leads off the primary control for the thermostat, if this activates the burner then either find the break in the thermostat wire line or replace the entire line.

20. Draft rheostat on primary control set too low.

Remedy: Switch draft setting to next highest setting.

21. Draft rheostat on primary control set too high.

Remedy: Switch draft setting to next lowest setting.

22. Defective blower motor.

Remedy: Depress white button on fan limit control to check blower activation. If not activated, pullout white button and connect power directly to blower leads, if not activated by direct power then remove and replace blower.

23. Loose coupling on cup drive assembly.

Remedy: Tighten set screw down onto flat part of shafts with allen wrench. Remember that the motor can be turning and everything looks like it is moving, but actually the couplings are just turning, not the shaft or the cup.

24. Loose coupling on auger drive assembly.

Remedy: Tighten set screw down onto flat part of shafts with allen wrench. See second comment above to note.

25. Burner limit 200-degree manual reset popped.

Remedy: Depress red button in between cup and auger motor. Verify correct operation of the cup, auger, and draft inducer motors. Possible motor failure evident.

26. No voltage to stove.

Remedy: Check power backward, j-box, power cord, outlet, circuit breaker, etc. Also check 3 amp fuse in primary control.

27. Too many appliances on the circuit.

Remedy: The unit should be on a separate circuit.



28. Too much chimney draft.

Remedy: Check draw with a draft gauge. Maximum draft .08 inches. If draw exceeds .08 reduce chimney outlet to accomplish.

29. Too little draft.

Remedy: Check draw of chimney with a draft gauge. Minimum draft .04 inches. May have to add more chimney.

30. Improper thermostat location.

Remedy: Relocate thermostat to location that reflects better overall desired temperature scheme.

31. Thermostat set too high.

Remedy: Turn it down to a more comfortable setting.

32. The heat demand of the house is too great for the BTU output of the furnace.

Remedy: Re-examine the area to be heated and the calculated heat loss. The furnace may be too small for the house. The furnace could be working perfectly but the demand is too great. That's the reason why we build different size furnaces. Remedy, get a larger furnace, or lower the heat loss of the home.

33. Unit is oversized for the area to be heated.

Remedy: Replace with a smaller unit, or provide more air distribution to other rooms.

34. Not enough pellets placed in firepot on start-up to bring the furnace up to lock in temperature on the safety disc.

Remedy: Stop operation, let the unit cool (never place pellets by hand into a hot firepot), and re-light with more (2-3 cups) pellets in the firepot.

35. Door or glass seal worn or broken.

Remedy: Replace with new gasket.

36. Draft inducer motor defective.

Remedy: Remove inducer motor from housing and connect to direct power, if non-functioning, replace with new motor.

37. Flue vent outlet blocked.

Remedy: Check piping and outlet to verify clear passage.

38. Summer (white) fan button pushed in on fan limit control.

Remedy: Pull button back out to auto position.

39. Air shutter on draft inducer too far open.

Remedy: Close down air shutter to 50%.

40. Air shutter on draft inducer too far closed.

Remedy: Open air shutter up to 50%.

41. Dust present due to carelessness when loading the stove.

Remedy: Take your time when loading pellets into hopper.

42. Unit has run out of fuel.

Remedy: Load hopper.

43. Undersized or overloaded service wiring.  
Remedy: Call your electrical contractor.
44. Power surge.  
Remedy: Call your electrical contractor.
45. Power short in unit.  
Remedy: Locate short circuit and correct.
46. Pellets in hopper are giving off an odor.  
Remedy: Change the brand of pellets you are using, some species of wood have unpleasant odors.
47. Mounting bolts on the blower are loose.  
Remedy: Tighten the mounting bolts.
48. Remote thermostat is not level.  
Remedy: Level the thermostat using a water bulb.
49. Ash pan door or other heat exchanger cover plate not on tight.  
Remedy: Tighten all nuts and check all gaskets.
50. Thermostat wires are shorting out.  
Remedy: Remove thermostat from the base, if burner continues to run, go back to tie in at primary control yellow leads, disconnect and separate, if burner stops, then you have a short in the remote wires. Trace and correct or replace. Look for tacks or nails through wires.
51. A bearing is failing on the blower motor.  
Remedy: Replace the blower.
52. Fan limit control is stuck.  
Remedy: Make sure that the white button is in the auto position, tap the fan limit control lightly. If this does not shut of the blower then replace the fan limit control.
53. Bad pellets.  
Remedy: Are you using approved pellets that meet the manufacturer's specifications? Use of non approved pellets will impair the functioning of your stove and may void your warranty.
54. That's the nature of the Honeywell T87F thermostat.  
Remedy: Adjust thermostat to your comfort level not a numbered dial.
55. Normal draft inducer hum anytime the unit is plugged in.  
Remedy: Install duro-dyne duct isolator.
56. Blower blades are dirty and full of lint and/or hair.  
Remedy: Clean the blades.
57. Draft inducer blades are dirty and full of lint and/or hair.  
Remedy: Clean the blades.
58. Furnace venting improperly installed.  
Remedy: Check installation manual to verify correct install on unit.

59. Aluminum air filter is dirty.

Remedy: Remove from furnace and wash.

60. Inadequate return air. Too small, restricted, or is pulling unconditioned air.

Remedy: Consult qualified HVAC ducting contractor for proper installation.

# PARTS LIST

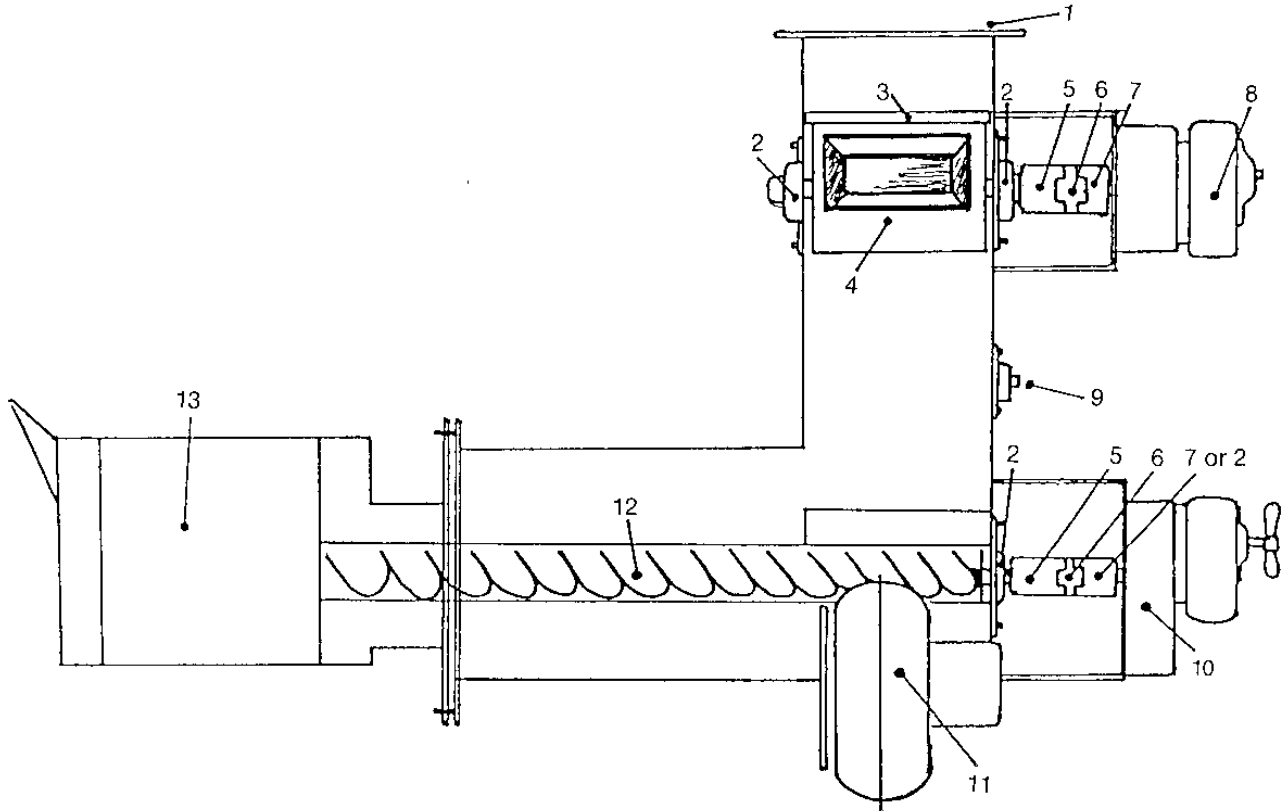

1. Hopper connector flange	F000221P	8. Cup motor	F000101P
2. Pillow block ball bearing	F000505P	9. Manual reset	F000105P
3. Cutting blades (2) ea.	F070513P-2	10. Auger motor	F000102P
4. Fuel metering cup	F070512P	11. Draft inducer	F000103A
5. 1/2" lovejoy coupling	F000507P *	12. Auger/shaft assembly	F070910P
6. Spider	F000515P	13A. Fire pot (complete) **	F070954A (corn)
7. 1/2" lovejoy coupling	F000507P *	13B. Cast pot liner **	F062700P (corn)
		13C. Pellet pot	F070903S (pellet)

\* Durham or Dayton brand auger motors use 3/8" coupler.

Merkle-Korff brand auger motor uses 1/2" coupler.

\*\* Corn pots are 2 piece units consisting of a stainless steel holder with a removable cast iron liner.



WARRANTY  
NON TRANSFERABLE

MODEL: GBU070 SERIAL NUMBER: \_\_\_\_\_

DATE PURCHASED: \_\_\_\_\_ FROM: \_\_\_\_\_

### Complete Unit Warranty

The manufacturer provides a warranty on all steel parts (except burn pot) and electrical components against defects in material or workmanship under normal use and maintenance for a period of one (1) year from the installation date. There is expressly no warranty on the following components: burn pots, fibreglass rope gasket, paint, or gaskets. This warranty covers defects in materials and workmanship in covered components, provided the product has been installed and operated strictly in accordance with Manufacturer's printed instructions. This warranty does not cover damage or breakage caused by improper handling, misuse or unauthorized modification. Without limiting the foregoing, the use of fuels other than pelletized wood or fuel corn will void all warranties and liabilities. **Commercial** applications are warranted for a period of three (3) months on steel parts and electrical components. Pinnacle Stoves Sales Inc. reserves the right to determine commercial applications. All claims under this warranty must be made in writing to the Manufacturer at Pinnacle Stove Sales Inc, 1089 Hwy 97N, Quesnel, BC V2J 2Y3 and should include the following.

- 1.Name, address, and telephone number of servicing dealer.
- 2.Name, address, and telephone number of purchaser
- 3.Date of purchase
- 4.Model & serial number of unit.

5.Nature of the defect, malfunction and/or complaint. Local representatives are to inspect parts and or unit. If the inspection indicates that the failure was due to defective material or workmanship in covered components and that the other terms and conditions of this warranty have been complied with the manufacturer's sole duty and liability under this warranty shall be limited to the manufacturer's replacement or repair, at manufacturer's option, of the defective unit or part. The purchaser shall assume all costs of shipping to and from the manufacturer. Removal, reinstallation and diagnostic costs are not covered under this warranty.

### Extended Parts Warranty

In addition to the above complete unit warranty, the following applies:

- Five (5) year extended warranty, pro-rated, on heat exchanger, residential use.
- One (1) year extended warranty, pro-rated, on heat exchanger, commercial use

NEITHER THE MANUFACTURER, NOR THE SUPPLIER TO THE PURCHASER, ACCEPTS RESPONSIBILITY, LEGAL OR OTHERWISE, FOR INCIDENTAL OR CONSEQUENTIAL DAMAGE TO PROPERTY OR PERSONS RESULTING FROM THE USE OF THIS PRODUCT, ANY WARRANTY IMPLIED BY LAW, INCLUDING BUT NOT LIMITED TO IMPLIED WARRANTIES OF MERCHANTABILITY OR FITNESS, SHALL BE LIMITED TO ONE YEAR FROM THE DATE OF ORIGINAL PURCHASE. WHETHER A CLAIM IS MADE AGAINST THE MANUFACTURER BASED ON A BREACH OF THIS WARRANTY OR ANY OTHER TYPE OF WARRANTY, EXPRESSED OR IMPLIED BY LAW, MANUFACTURER SHALL IN NO EVENT BE LIABLE FOR ANY SPECIAL, INDIRECT, CONSEQUENTIAL OR OTHER DAMAGES OF ANY NATURE WHATSOEVER IN EXCESS OF THE ORIGINAL PURCHASE PRICE OF THIS PRODUCT. ALL WARRANTIES BY MANUFACTURER ARE SET FORTH HEREIN AND NO CLAIM SHALL BE MADE AGAINST MANUFACTURER ON ANY ORAL WARRANTY OR REPRESENTATION.

Some states/provinces may not allow the exclusion or limitation of consequential damages, or limitations of implied warranties, so the limitations or exclusions set forth in this warranty may not apply to you. This warranty gives you specific legal rights and you may also have other rights which vary from state to state, province to province.