



TM

**Gayley/LecMay**

**400 and 600  
WOODSTOVES**

x1 = Coal Hal handles  
 2 = Pots & pans = iron  
 3 = Tea Kettle in stove  
 x4 = Cast iron extension service = optional  
 5 = 34 1/2" legs height  
 6 = A-1 p 16-

**CONTENTS**

INTRODUCTION .....	8 p 19
FEATURES .....	9 p 23
General - Cooking .....	10 p Stove polish
SPECIFICATIONS CHART .....	11 p Hoe for code
PREPARING FOR YOUR STOVE .....	17
Stove Location - Stove Clearances - New Chimneys - Existing Chimneys - Fabricated Chimneys .....	
ASSEMBLY AND INSTALLATION .....	21
Removing the Packaging From the Stove - Assembling and Installing the Stove - Changing the Firebox Size .....	
CARE AND UP-KEEP OF YOUR STOVE .....	25
FIRING YOUR STOVE .....	27
Starting a Fire - Maintaining a Fire Overnight - Removing the Ashes .....	
FIREWOOD .....	29
Some Facts About Wood - Cordwood - Chart .....	
SAFETY .....	30
Creosote - Creosote Prevention - What to Do If a Chimney Fire Occurs - Chimney Fire Cause and Prevention - Combustible Material - Flammable Liquids .....	

Copyright 1977  
 Patents Pending

**The Cawley Stove Company, Inc.**

27 N. Washington St., Boyertown, PA 19512  
 215/367-2643

*Chase please return*

16" legs

## INTRODUCTION

*24 gauge sheet metal*

The first box stoves were invented in Germany toward the end of the 15th century and brought to Pennsylvania by early German settlers. These stoves were constructed of five cast iron sides or plates with the open end facing either the fireplace or outside the house for venting.

The six plate stoves which used a stove pipe for venting, and is the ancestor of the present day box stove, was in use by the middle of the 18th century. Many Pennsylvania German homes were designed to use these efficient sources of heat along with floor vents to insure warmth throughout the house.

In 1836 Isaac Orr, of Washington, D.C., improved the efficiency of woodburning by designing a stove with sealed joints and a controllable draft, patenting the first "airtight" woodstove.

With the accessibility of inexpensive fossil fuels early in this century, the use of wood heat quickly declined. It has now become evident that the fossil fuel supply is finite and that its cost will continue to rise. Many people are searching for alternative sources of energy and a life-style of greater self-sufficiency. For a large number of these people, the answer, at least in part, is wood heat.

After using and experimenting with various woodstoves, from European imports to domestic potbellies and Franklin fireplaces, industrial designers C. Robert Cawley, Jr. and Robert C. LeMay, Jr. developed the Cawley/LeMay #400 and #600 woodstoves incorporating qualities they felt to be important to our present and future life-styles.

These woodstoves feature design improvements which include greater heat efficiency, durability, convenience, and more cooking versatility.

*24 gauge pipe  
24 gauge floor  
sheet metal*

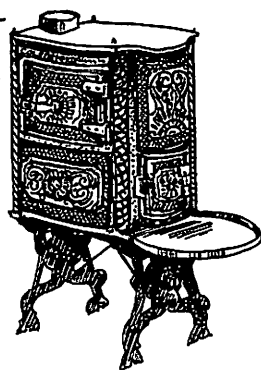

Colebrookdale Furnace (1720)  
Ten-Plate Cookstove

**THE STOVE PARLOR**  
The Quality Stove People  
200 Canal Street  
Dexter, N. Y. 13834 1  
Phone: (315) 639-3214



600 WOODSTOVE



400 WOODSTOVE



## FEATURES

These large, fully-baffled, airtight woodstoves are designed to burn slowly and efficiently from front to back.

The draft control wheel on the front of the loading door and the draft distribution plate on the rear work in combination to divide the incoming air effectively for use in primary and secondary combustion.

The interfacing surfaces of the stove door and the draft adjustment wheel are machined to insure a tight seal and smooth action. Each fully gasketed door is then fitted to the front plate, giving these stoves their important airtight quality.

A grid in front of the top baffle plate acts as a thermal reservoir, stabilizing the temperature of the remaining volatile gases and creating a turbulence to thoroughly mix these gases with oxygen, thus aiding secondary combustion.

The large fireboxes of the Cawley/LeMay woodstoves require less frequent loadings. Occasionally your stove may provide too much heat for a given space or season of the year. The interior side baffles of both stoves may be reversed to create smaller fireboxes — a more efficient alternative than using lower draft settings to achieve less heat output. (See **Assembly and Installation.**)

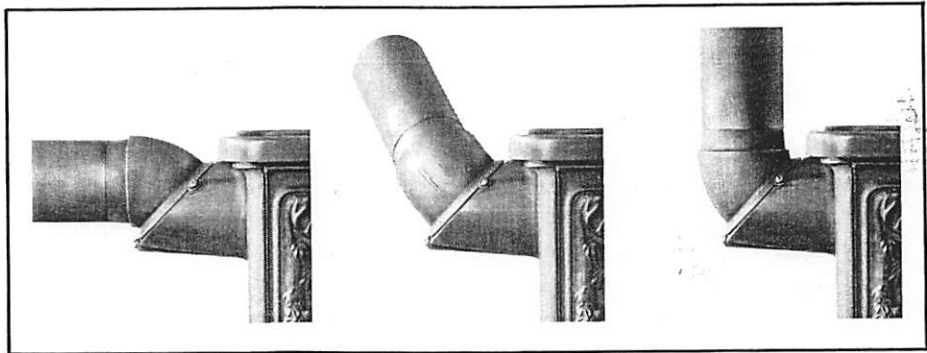
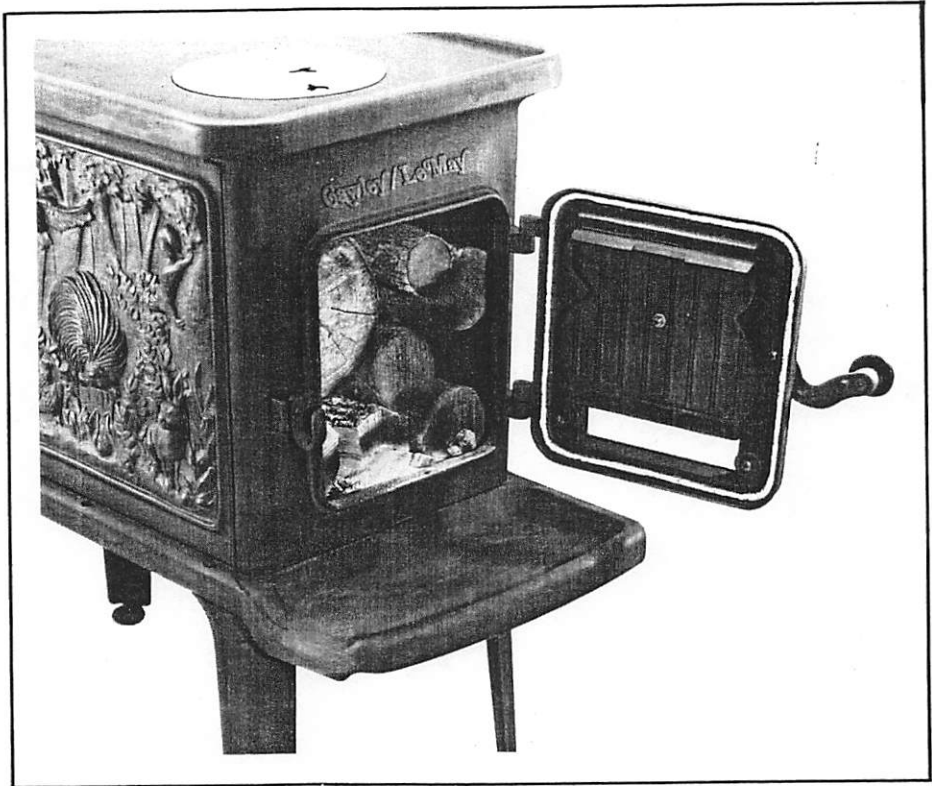



The large 9 1/2" x 10 1/2" stove door is at a convenient height for loading. Between loadings the fire condition may be viewed through the door window. Ashes that may spill from the door opening while the fire is being tended are caught by the ample sweep shelf and easily removed.

The convoluted base plate in the firebox area provides greater strength, less heat expansion, and better ash or sand retention, and is sloped at the same angle as the top baffle plate. This enables the fire chamber to be fully loaded without jamming the wood against the rear of the top baffle or lifting it out of position, a problem encountered with the wedge-shaped fireboxes of many other box stoves.

Two features which aid in installation are the rotating cast iron flue collar at the rear of the stove, which will withstand the punishment of heat better than a sheet metal elbow and can be adjusted to accept the flue pipe at any given point within a circle, and adjustable leveling feet which will stabilize the stove on an uneven hearth surface. ✓

Cast parts are made of an iron specifically formulated for the structural integrity and good thermal qualities required in woodstoves. These parts are carefully engineered utilizing deeply rounded, structural, and visually pleasing forms.

All joints are of tongue-and-groove construction and grouted with furnace cement during assembly. Heavy bolts hold the stove firmly together.

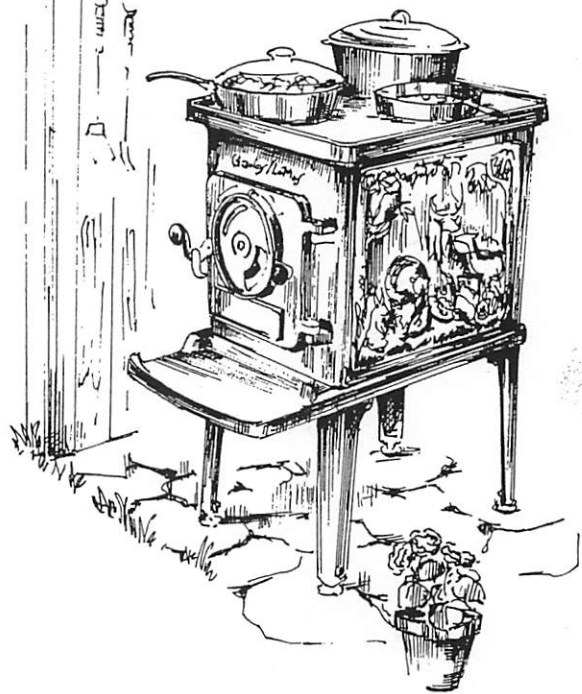
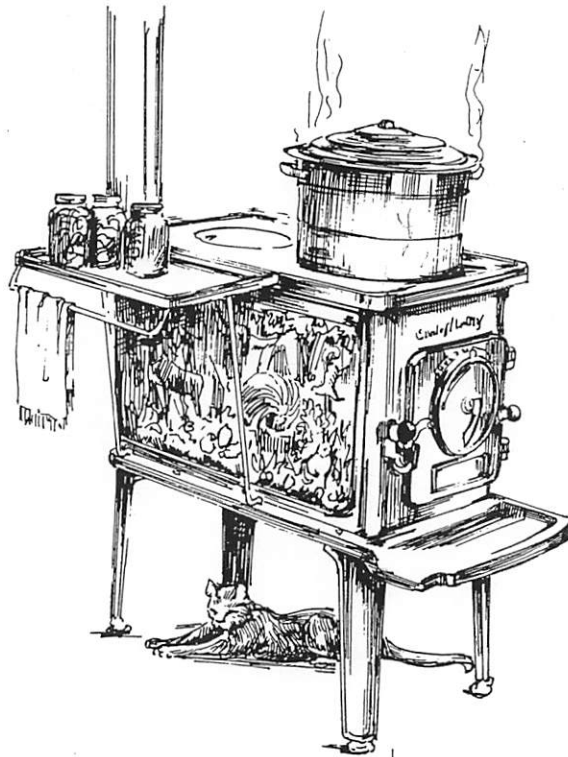

## COOKING

The low heights of many other stoves make cooking uncomfortable and the minimal, irregular top surfaces greatly limit the use of cookware. The tops of such stoves proved to be a hazard, allowing cookware to be inadvertently pushed off the edge. The Cawley/LeMay woodstoves stand at a comfortable kitchen counter height. The raised and rounded edges surrounding the stove top insure the safer use of multiple pieces of cookware, lessen the chance of injury, and impart a pleasing flow to the overall design.

With the rising costs of energy, the financial savings resulting from home food preservation are considerably diminished when using conventional gas or electric ranges. The Cawley/LeMay stoves will easily accomodate a large canning tank. (The #600 stove will even hold two!) L

Cooking temperatures can be controlled by moving your pans to different areas of the cook top or by removing the cooking lids and placing the pans directly over the fire.

The perpetually simmering kettle on the back of the stove provides constant hot water and is an excellent humidifier.

An optional cast iron extension surface upon which hot pots and pans may be set, or from which food may be served, is available as an accessory. L

For more comfortable summertime cooking and preserving of food, a suitable shelter and proper chimney can be constructed out of doors for either stove.

The Cawley/LeMay woodstoves are as elegant in the atmosphere of gourmet cooking as they are practical for everyday cooking and heating.





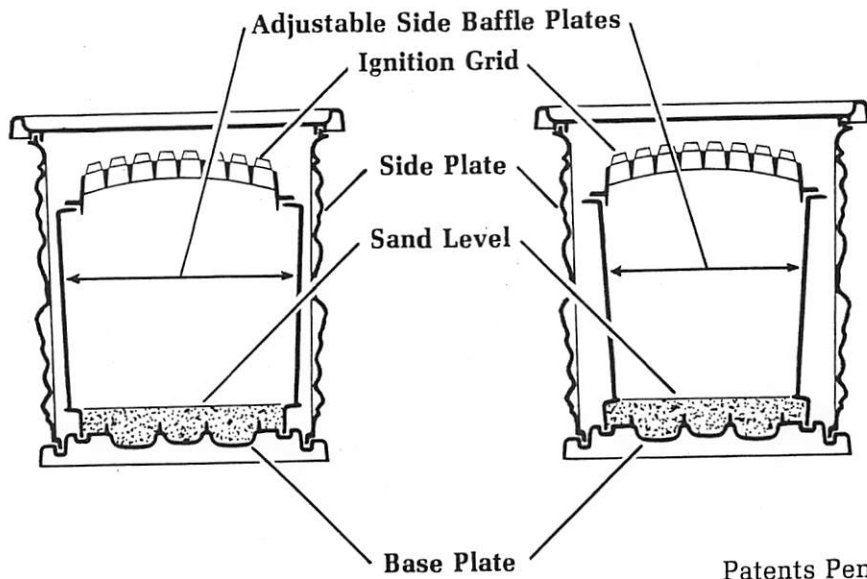
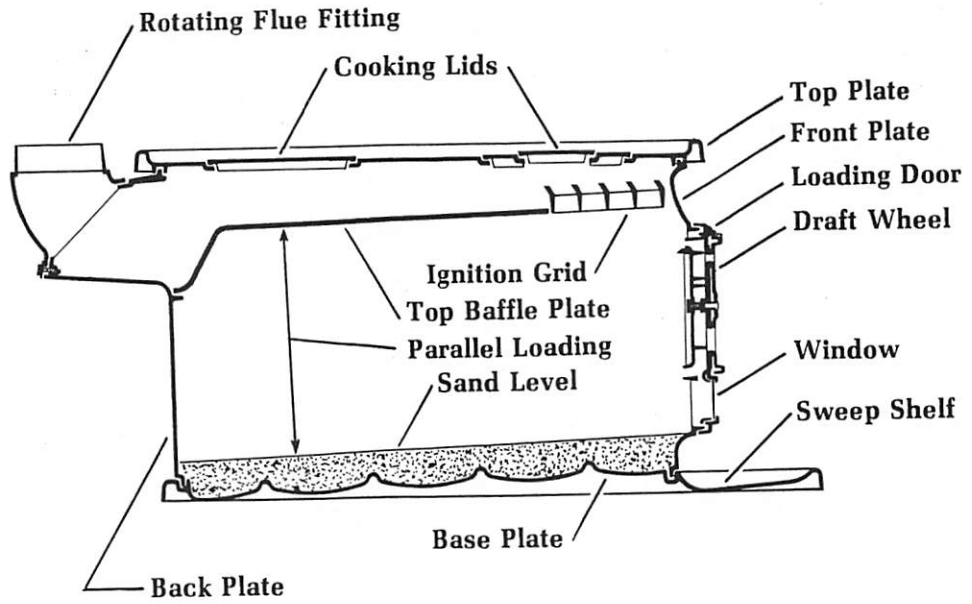

Patents Pending

# SPECIFICATIONS

Cawley/LeMay 400 & 600 Woodstoves

	400	600
Height (Standard Legs, supplied with stove)	34-1/2"	<u>34-1/2"</u> <span style="float: right;">2</span>
(Medium Legs)	30-1/2"	30-1/2"
(Short Legs)	26-1/2"	26-1/2"
Width (overall)	18"	18"
Length (overall)	37"	45"
Weight	300 lb.	385 lb.
Flue Size	6"	6"
Log Length	16"	<u>24"</u>
Log Length, maximum	19"	27"
Height to Center Line of Flue (Standard Height)	32"	<u>32"</u>
(Medium Height)	28"	28"
(Short Height)	24"	24"
Cook Top Size	22" x 16"	<u>30" x 16"</u>
Primary Combustion Chamber <sup>1</sup> (Full Size)	2971 cu.in.	4190 cu.in.
Primary Combustion Chamber <sup>1</sup> (Reduced Size)	2523 cu.in.	3578 cu.in.
Heating Range <sup>2</sup>	3500-7500 cu.ft.	<u>5500-10,000 cu.ft.</u>

- 1) Does not include either the area required by the sand at the bottom of the firebox, or the secondary combustion chamber above the baffle plate. ✓
- 2) The heating range is approximate and is dependent on the following: location of your house, insulation, chimney structure and location, type and condition of the wood; and the method of firing the stove.



The strong, direct lines and sturdy character of the Cawley/LeMay woodstoves offset the intricate scenes of native wildlife created by Martha H. Cawley, widely recognized wildlife artist and sculptor.

Copyright 1977  
Patents Pending





The Cawley/LeMay #400 and #600 woodstoves are uncompromising in quality, American-made, 100% cast iron, and built to last for generations of use. We believe these stoves to be the finest heating and cooking woodstoves available. Although an expensive investment now, one of these stoves could become a most valuable asset in the future.

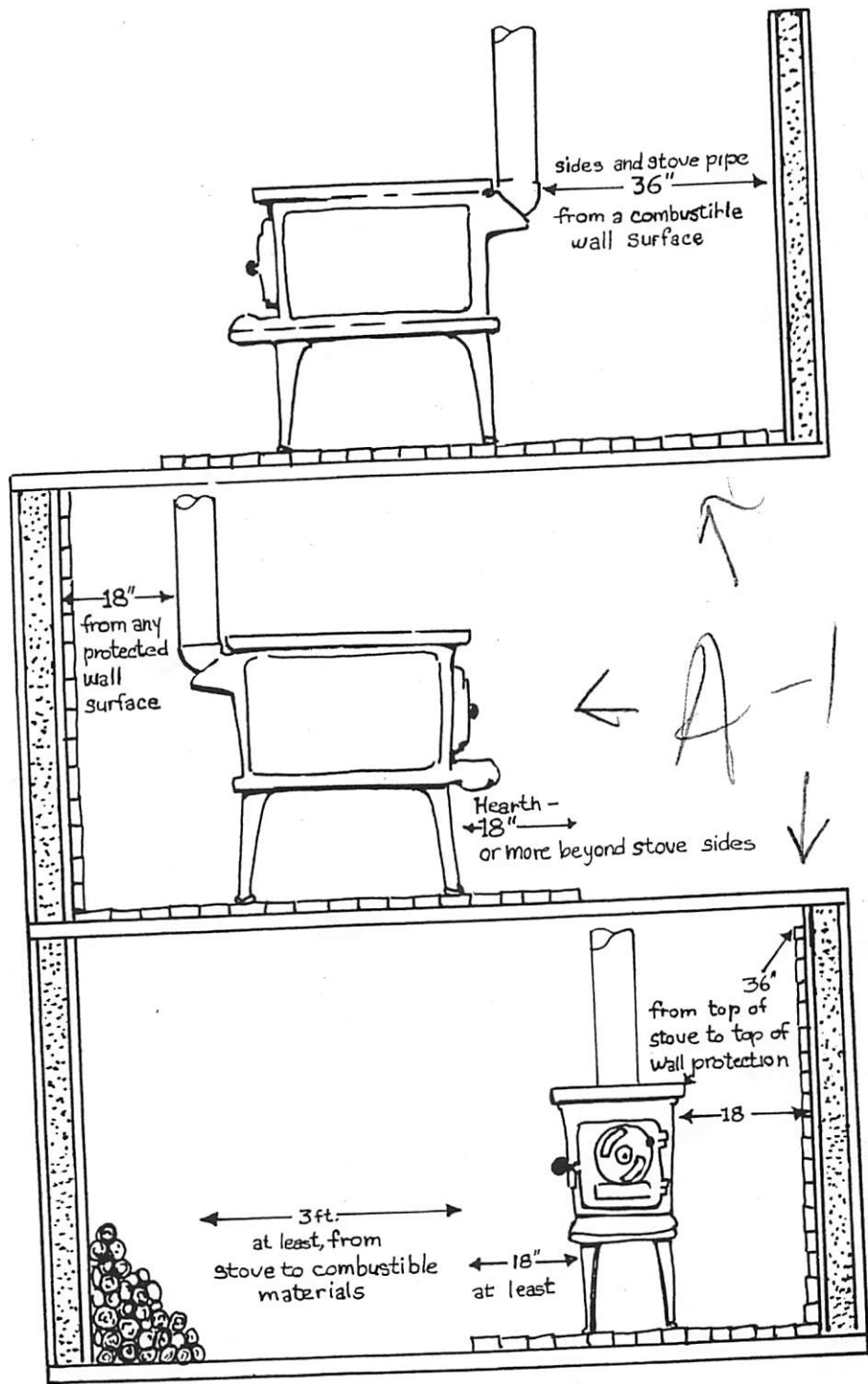

## PREPARING FOR YOUR STOVE

A woodstove, unlike a hot air furnace, does not use forced convection to distribute heat evenly throughout the house. It is a point source of heat which depends on natural convection. Therefore, careful advanced planning and attention to the location of your stove and chimney will be important to the overall efficiency of the installation.

The proper location for your stove should be determined by the layout of your house and the space you wish to heat, whether it is one room, several rooms, or the whole house.

The stove should be placed as centrally as possible in the space to be heated. If heating one room, locate the stove on the coldest or draftiest side of the room. If heating two or more rooms or a greater part of the house, you may help the natural circulation by allowing the heat to rise up the stairwells or by putting vents in floors and above doors.

**Note:** Do not place any stove in a restricted area such as an alcove, where dangerously high heat levels may be trapped due to inadequate circulation.

The hearth or non-combustible surface upon which the stove stands should extend a minimum of 18" beyond all sides of the stove. If you plan to use your stove for cooking, be sure to allow ample additional standing area for comfort when cooking. Some non-combustible materials you may consider for the hearth are brick, flagstone, quarry tile, and stove board (metal covered asbestos board).

The stove sides must be at least 36" away from any combustible material, and 18" from any protected, combustible surface. Some materials which may be used to protect combustible wall surfaces are brick, stone, asbestos board covered with 28-gauge sheet metal, or a minimum of 28-gauge sheet metal spaced out with one-inch, non-combustible spacers.

These materials are available from most stove stores and many hardware stores and lumber yards. These must be installed according to manufacturer's instructions.



## CHIMNEYS

### NEW CHIMNEYS

The warmer the chimney, the better the draft and the less likely the condensation of creosote. Therefore, a new chimney should, if possible, be located inside the house and not on an exterior wall, where its warmth would be lost to the outside.

A new chimney should be constructed according to local building codes. A Class "A" single flue should incorporate no more than one heating appliance, minimum 8 x 8 flue liner.

The cost of adding additional flues for future use is minimal when building a new chimney. L

### EXISTING CHIMNEYS

An existing chimney should be checked out by a chimney expert. It should be fully lined, structurally sound, and free of any blockages. C

**Note:** A chimney that was adequate for a gas or an oil furnace may not be so for a woodstove, which has a much higher burning temperature.

Stoves vented into an existing fireplace should be properly prepared.

### FABRICATED CHIMNEYS

There are a number of excellent fabricated chimneys available which are considerably less expensive than new masonry chimneys. These chimneys should be installed according to the manufacturers' instructions. It is of the utmost importance to maintain the recommended clearances between the chimney and any combustible surfaces.

Chimney construction and structural alterations in your house are beyond the scope of this handbook. We strongly advise obtaining more information.

Two books that we found to be very candid and informative are:

**The New Improved Wood Heat** by John Vivian, (Rodale Press, Inc., Emmaus, Penna. 18049)

**The Complete Book of Heating With Wood** by Larry Gay, (Garden Way Publishing, Charlotte, Vermont 05445)

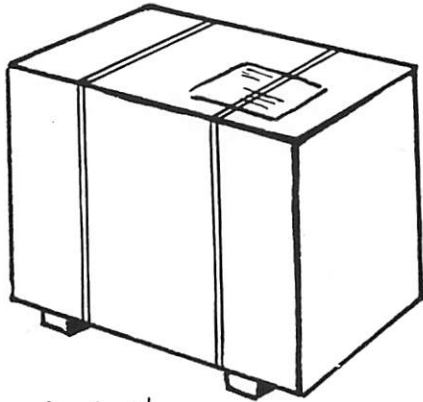

Arrival

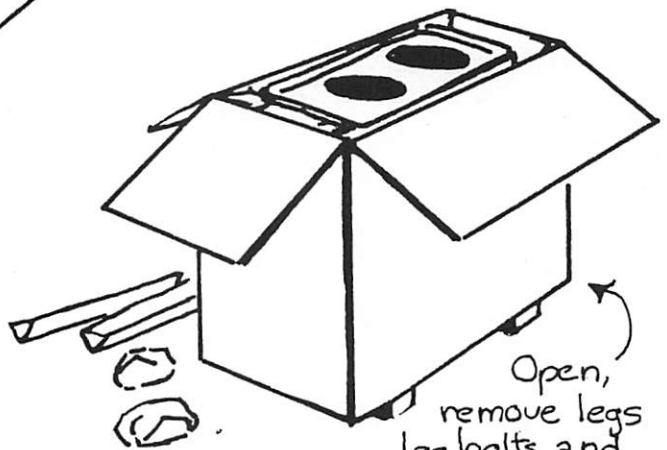

Open,  
remove legs  
leg bolts and  
washers, and  
adjustable feet

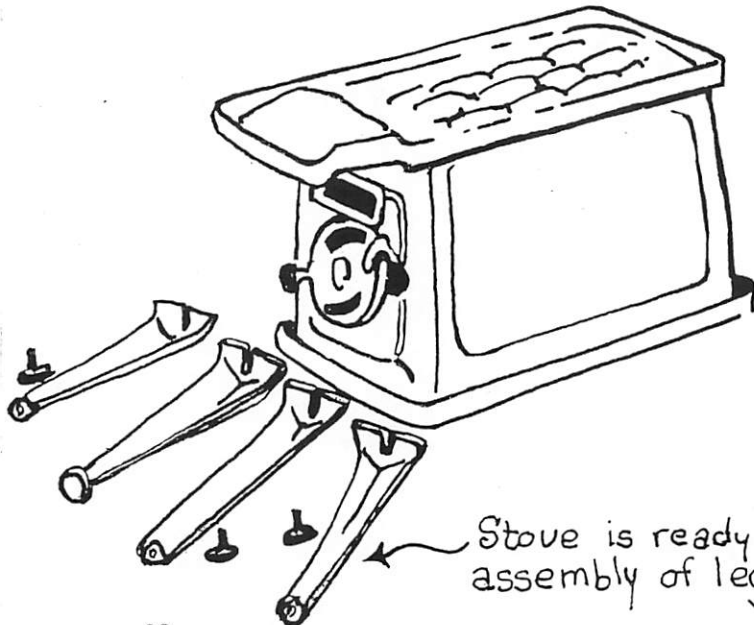

Stove is ready for  
assembly of legs.

## ASSEMBLY AND INSTALLATION

Your stove was thoroughly inspected and carefully packed before leaving the factory. It should arrive in perfect condition. However, check the stove over carefully. If there is any damage, report it immediately to the trucking company and to us.

### REMOVING THE PACKAGING FROM THE STOVE

1. With the help of a minimum of two people, move your stove to its approximate location.
2. Cut the 2 shipping bands.
3. Open the flaps of the carton.
4. Remove the instruction manual, cooklids, lid lifter, furnace cement, legs, leg bolts, and the corrugated cardboard stiffeners.
5. Lift the carton from the stove.
6. Remove the rotation draft collar from behind the stove.
7. Check to see if the internal baffle plates, grid and loading door are still secure. (Do not remove the packing material in the top of your stove at this time.)
8. Carefully turn your stove over on its top.
9. Using an adjustable wrench or a 9/16" open end or box wrench, remove the 4 bolts holding the wooden pallet to the base of the stove.
10. After removing these bolts the wooden pallet can be removed.

**Caution:** Do not open the stove door when it is in the upside-down position. It may come off the hinges.

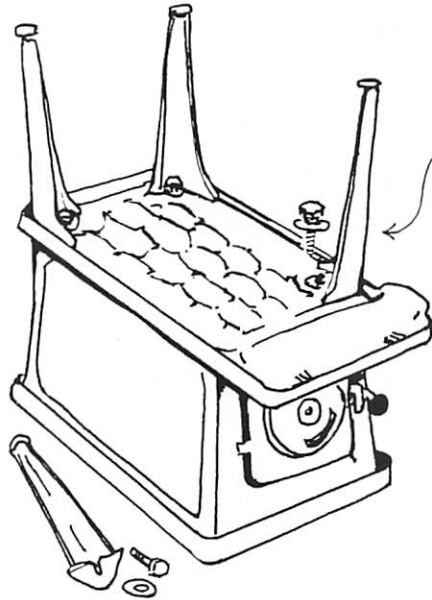

Assemble legs  
with bolts and washers.  
Note Place wide flange of  
leg toward side of stove.

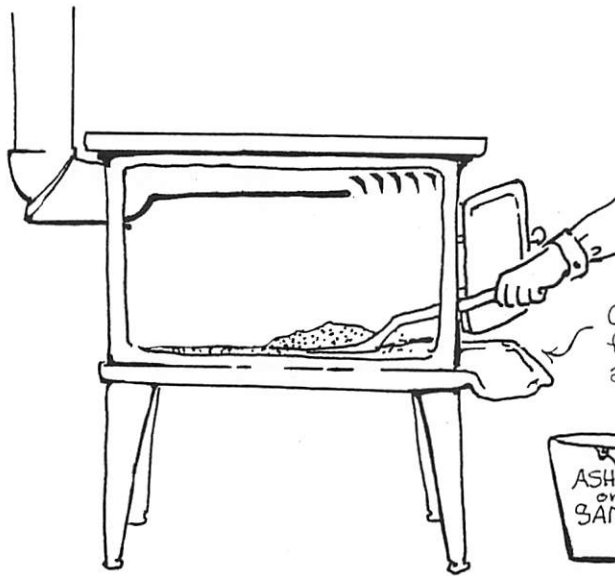

Cover stove  
floor with  
ashes or sand.





## ASSEMBLING AND INSTALLING YOUR STOVE

1. With the stove in its upside-down position, assemble the 2 right hand and 2 left hand legs to the base plate using the bolts and washers supplied.
2. Carefully turn the stove upright, taking care not to put the full weight of the stove on only one or two of the legs.
3. Place the stove in its final position. Adjust the leveling feet for stabilization if required.
4. Remove the packing that is holding the top and side baffles in position.
5. Determine the correct position of the rotating flue collar in relation to your stove pipe and mark it so that it may be easily repositioned.
6. After applying furnace cement to the bottom flange of the rotating flue collar, replace it in its final position. Tighten it down with the 3 round-headed machine screws and washers supplied with the stove.
7. Make the final connection between the flue pipe and the chimney.

**Caution:** All sections of standard stove pipe should be put together with 3 sheet metal screws at each joint. If you are using fabricated stove pipe or chimney, be sure to follow the manufacturer's instructions.

8. Check to make sure the top and side baffle plates are in their proper positions — as far to the rear of the stove as possible.
9. Cover the stove floor with ashes or sand level with the ledge on the side baffle plates. (Either ashes or sand are fine, but ashes have a better insulating value.)
10. Place the 2 cooking lids on the stove top after removing the protective coat of oil with a solvent. (They should be lightly wiped periodically with cooking oil to prevent rusting.)
11. Your stove is now ready to fire.

### CHANGING THE FIREBOX SIZE

You may find that the heat output of your stove is too great for a given space or season of the year. By reversing the two side baffle plates, the fire chamber may be made smaller. (Reducing the size of the firebox is a more efficient means of achieving less heat output than continually using low draft setting.)

1. Stove must be cool.
2. Remove the cooklids and open the door.
3. Raise the ignition grid up against the top plate.
4. Move it to either the extreme right or left. Drop the opposite side down past the side baffle plate.
5. The ignition grid may now be carefully removed through the door at an angle.
6. The top baffle plate can now be removed in the same manner.

**Caution:** Be careful not to hit your fingers or the stove with any of these heavy cast iron parts as you remove them.

7. Pull the ashes or sand away from one of the side baffle plates.
8. Carefully remove that baffle plate from the stove. Rotate it lengthwise 180° , reinsert it through the door, and place back into the recesses, making sure that sand is not lifting it out of place. Hold the baffle plate against the side plate while pushing it all the way to the rear of the stove. A lug on the back plate will hold the side baffle plate in a vertical position.
9. The opposite baffle plate may now be reversed.
10. Double check to be sure that both side baffle plates are to the extreme rear of the stove.
11. The top baffle and the ignition grid may now be reassembled.
12. Smooth the ashes or sand out and you are ready to refire your stove.

## CARE AND UP-KEEP OF YOUR STOVE

The exterior of the Cawley/LeMay stoves may be kept clean with an occasional wiping, when the stove is cool, with a damp cloth or sponge.

Stove polish may be purchased from your stove or hardware store for occasional touch-ups.

The knobs on the door latch and the draft control wheel have a vitreous enamel finish. Avoid hitting them with hard objects. Small chips can be repaired by using high temperature gloss black enamel.

Door windows can be cleaned with water, detergent, and a scouring pad.

**Caution:** Do not use the stove door to assist in pushing over-sized wood into the firebox. The boro-silicate glass in the door window is designed to withstand the shock of high temperature fluctuations but is not made to withstand physical blows or pressures.

If for any reason the glass should get cracked, the stove may be fired and used until a new piece is obtained. However, if a piece is broken out thus letting additional air into the fire chamber, do not fire the stove until you have installed a new window and sealed it with furnace cement.

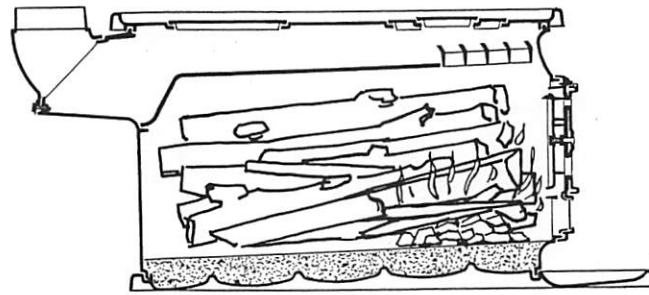
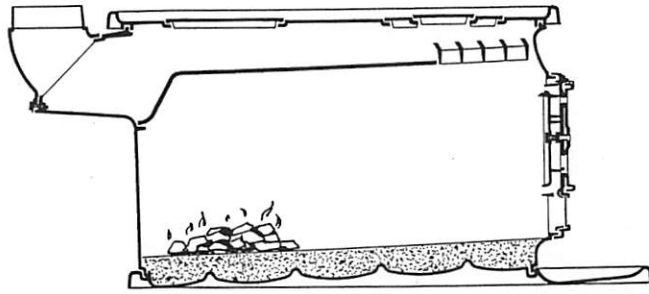
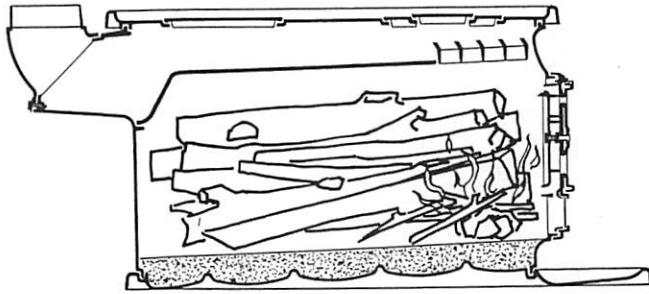
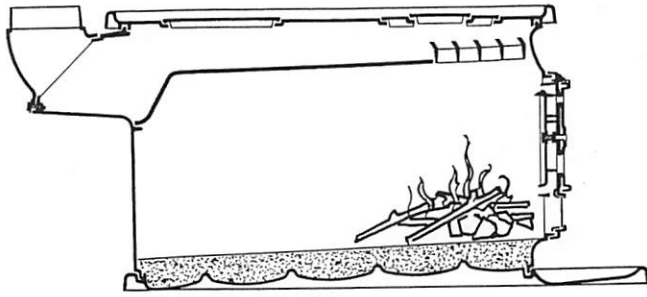

## FIRING YOUR STOVE

**Note:** Things to remember **before** firing your stove the first time:

Be sure there is a protective layer of ashes or sand covering the stove floor up to the ledge on the side baffle plates.

For the first few weeks the draft settings should be kept in the mid range (Nos. 5-7), except when starting the fire (No. 10), to gradually remove the internal stresses in the iron castings.

Never build a roaring fire in a cold stove or use it as a trash incinerator — the thermal shock may crack a casting.

### STARTING A FIRE

Build a small fire in the front of your stove, as you would in a fireplace, using a ball of newspaper, kindling, and small sticks. Close the door and open the draft all the way.

Begin adding full-length sticks, gradually increasing the diameters. Fill the firebox with a mixture of large and small split logs.

Close the door, keeping the draft open until the fire is well under way.

The draft wheel may then be shut down to the desired burning rate, generally Nos. 5-7.

It is most efficient to maintain your fire in the mid to upper draft ranges most of the time.

**Note:** Creosote will tend to form at low settings.

### RELOADING THE FIREBOX

The best method of tending the fire is to wait until the present load of wood has been reduced to coals in the back of the stove before reloading.

These coals should be pulled to the front of the stove with the hoe.

Full length whole and split logs may now be loaded.

### MAINTAINING A FIRE OVERNIGHT

Use hardwood (It causes less creosote build-up than softwoods.) and keep the draft setting in the mid range. In the morning, fire the stove in the high range for a short period of time to aid in drying out and flaking off any creosote that has built up overnight.

### REMOVING THE ASHES

Ashes may be removed as often as required during the regular firing of the stove by separating the spent ashes from the live coals.

Pull the ashes to the front of the stove where they may be removed with a shovel, or catch them in a metal pan held under the door.

See "Disposal of Ashes" in SAFETY Section.

WOOD TYPE	WEIGHT PER CORD <sup>1</sup>			AVAILABLE HEAT PER CORD <sup>1</sup>		Btu/Lb <sup>3</sup> Air Dry <sup>2</sup>	HEATING VALUES	STARTING EASE	COALING	FRAGRANCE	SPARKS	SPLITTING EASE
	Weight Green Pounds	Water Evaporated Gallons	Weight Air Dry <sup>2</sup> Pounds	Green Million B.t.u. <sup>3</sup>	Air Dry <sup>2</sup> Million B.t.u. <sup>3</sup>							
Ash	3,840	50	3,440	16.5	20.0	5,814	Medium	Fair	Good	Slight	Few	Easy
Aspen	3,440	160	2,160	10.3	12.5	5,787	Low	Easy	Poor	Slight	Moderate	Easy
Beech, American	4,320	70	3,760	17.3	21.8	5,798	High	Hard	Good	Slight	Few	Hard
Birch, Yellow	5,460	223	3,680	17.3	21.3	5,787	Medium	Easy	Good	Slight	Moderate	Fair
Elm, American	4,320	170	2,960	14.3	17.2	5,811	Medium	Fair	Good	Fair	Very Few	Doesn't
Hickory, Shagbark	5,040	100	4,240	20.7	24.6	5,801	High	Fair	Excellent	Slight	Moderate	Easy
Maple, Red	4,000	100	3,200	15.0	18.6	5,813	Medium	Fair	Good	Good	Few	Fair
Maple, Sugar	4,480	100	5,280	18.4	21.3	5,788	High	Hard	Excellent	Good	Few	Fair
Oak, Red	5,120	180	3,680	17.9	21.3	5,788	High	Hard	Excellent	Fair	Few	Fair
Oak, White	5,040	140	3,920	19.2	22.7	5,791	High	Hard	Excellent	Fair	Few	Fair
Pine, Eastern White	2,880	100	2,080	12.1	13.3	6,394	Low	Excellent	Poor	Good	Many	Very Easy

Data supplied by the Forest Products Laboratory, Madison, Wisc. and the U. S. Forest Service.

1) Containing 80 cubic feet of solid wood.

2) Air-dry means with 20 percent moisture in terms of oven-dry weight, or 16.7 percent in terms of total air-dry weight.

3) 1 B.t.u. (British thermal unit) is the amount of heat required to raise the temperature of 1 pound of water 1° F. Available heat equals calorific value, minus loss due to moisture, minus loss due to water vapor formed, minus loss in heat carried away in dry chimney gas. Flue temperature 450° F.; no excess air.

16" Face Cord

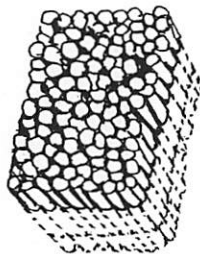

24" Face Cord

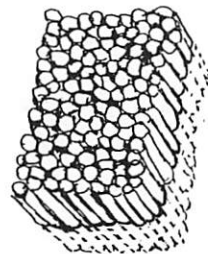

Full Cord

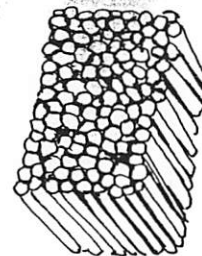

## FIREWOOD

Wood is one of our most perfect fuels. It is renewable, easier to obtain than coal, gas, or oil, and environmentally clean. When wood is burned efficiently, the products of combustion closely match those of the natural process of decay.

With careful, considerate management, our nation's woodlands will be able to fulfill a substantial part of the heating needs of those who wish to burn wood.

### SOME FACTS ABOUT WOOD

Green wood may contain up to 40% water (approximately one-half ton or 125 gallons of water per cord). When green wood is burned, the heat required to change this water into steam is lost energy. This heat loss lowers the firebox temperature to a point where it can no longer support secondary combustion, thus further decreasing your stove's efficiency. The total effect is low heat efficiency and high creosote build-up.

Splitting firewood promotes faster drying and a hotter, more active fire, due to the increased surface area of the wood.

Split hardwood should dry at least eight months — a year is preferable.

— When stacking wood, arrange it by type and size.

If you have a wood lot, check with your state or county forestry agent for advice on how to harvest the trees for firewood.

### CORDWOOD

A standard cord of wood measures 8 ft. long by 4 ft. high by 4 ft. deep (approximately 128 cubic feet). Most of us, however, cannot burn a log that is four feet long. We must either cut it ourselves into shorter lengths (the least expensive method) or order what are called face or stove cords. These cords are still 8 ft. long and 4 ft. high, but are made up of logs of only 16" or 24" in length. Hence three 16" face cord (approximately 43 cu. ft. each) or two 24" face cords (approximately 64 cu. ft. each) would equal one standard cord.

## SAFETY

### FLAMMABLE LIQUIDS

Flammable liquids should never be used to start your fire nor should they be stored in the vicinity of your stove.

### DISPOSAL OF ASHES

Ashes should be placed in a metal container with a tight fitting lid. The closed container of ashes should be placed on a noncombustible floor or on the ground, well away from all combustible materials, pending final disposal. If the ashes are disposed of by burial in soil or otherwise locally dispersed, they should be retained in the closed container until all cinders have thoroughly cooled.

### COMBUSTIBLE MATERIAL

Combustible material should **never** be heated to a point where you cannot rest your hand on it indefinitely. Draperies, furniture, wood, papers, etc., should be a minimum of thirty-six inches from your stove.

### CREOSOTE

Creosote is a natural by-product of the incomplete combustion of wood. It is a combination of acetic and pyroligneous acids and water. These are driven off by heat as a vapor and condense on cold surfaces such as the interior of stove pipes and chimneys.

Creosote is generally first noticed as a dark brown or black molasses-like material seeping from the seams of the stove pipe accompanied by an odor much like that of smoked ham.

If this condition persists, the creosote may build up gradually from a thin, shellac-like coating to one of considerable thickness. This is a highly flammable substance, the presence of which should be checked for regularly.

Incomplete combustion, the major cause of creosote, is primarily a result of:

1. Lack of adequate oxygen due to low draft wheel settings or poor chimney draft.
2. Low fire temperatures produced by inadequate draft, unseasoned, cold or wet wood.
3. Improper fuel that is soft and resinous and contains an overabundance of the creosote-forming chemicals.



Cold, exterior masonry chimneys and uninsulated stove pipe give the creosote vapor an excellent place on which to condense.

NOTE: Under no circumstances should an uninsulated stove pipe run up the outside wall of a building.

### CREOSOTE PREVENTION

All airtight woodstoves produce creosote at one time or another, especially in the low fire ranges. The best method of prevention is to fire the stove in its medium to upper ranges using hard, well-seasoned wood.

A properly tended stove in which hard, dry wood is burned with a brisk fire will have little or no creosote problem. C

### CHIMNEY FIRES

WHAT TO DO IF ONE OCCURS:

1. Shut the draft off with a SLOW AND EVEN MOTION.
2. Get everyone out of the house.
3. Call the fire department.
4. If closing the draft has not greatly reduced or extinguished the fire, large quantities of coarse salt may be thrown into the fire chamber and the door closed. W U

Caution: Never throw water on or into a hot stove.

### CAUSE

If a chimney fire does occur, it is usually after a considerable amount of creosote has built up and the stove is being fired within its uppermost range. When creosote reaches its ignition temperature (approximately 1000° F) with an adequate supply of oxygen, it will ignite with a roar, sounding very much like a jet plane. The stove pipe, and even the whole house, may vibrate.

### PREVENTION

Fire the stove in the mid to upper range of the draft control using dry, hardwood that has been allowed to warm up to room temperature.

If you fire your stove at the medium to low draft settings — for example, holding a fire overnight — fire the stove in the mid to upper ranges during the daytime to aid in harmlessly drying out and flaking off any creosote that may have built up during the period of low firing.

Creosote build-up may be checked in standard stove pipes by tapping the pipe with your fingernail at the time of installation. Remember — it will have a clear, metallic sound. This test should be made on a weekly basis after the stove is first installed and at a minimum of once a month thereafter. If the sound changes to a dull thud, it indicates that creosote formation may be taking place. The sections of stove pipe should be unscrewed and taken apart, visually inspected, and cleaned.

All chimney installations should be checked at least once or twice a year by an expert — more often if required. Additional information about this service may be obtained from either your local fire company or stove store.

You should have at least one, preferably two universal ABC fire extinguishers of five pounds or more. Your local fire department will be glad to give you additional information about the type and number of fire extinguishers to get, and where to place them in your particular situation.

**Additional information about stove safety and installation may be obtained from:**

National Fire Protection Association  
470 Atlantic Avenue, Boston, Mass. 02210

Three NFPA booklets that we found to be informative are:

**Using Coal and Wood Stoves Safely**  
NFPA No. HS-8 1974

**Heat Producing Appliance Clearances**  
NFPA No. 89M 1976

**Chimneys, Fireplaces and Vents**  
NFPA No. 211-1972

Before beginning any construction, check local fire codes, and building and zoning ordinances, and consult your insurance company.

## **LIMITED WARRANTY**

The Cawley/LeMay 400 and 600 woodstoves are manufactured with the utmost care, using the finest materials available. With reasonable care on your part, these stoves will provide warmth and pleasure for generations of use.

However, should any defects be found in the materials or workmanship of your stove within a period of 10 years from the date of original purchase, please notify The Cawley Stove Company, Inc., 27 N. Washington St., Boyertown, PA 19512, for instructions concerning repair or replacement of such parts (excluding finish and furnace cement.)<sup>1</sup>

Damage caused by deliberate abuse, misuse, or improper installation of your stove is not covered by this warranty.

This warranty does not cover damage occurring in transit. Be sure to file a claim with the carrier at once and to notify The Cawley Stove Company, Inc.<sup>2</sup>

This warranty gives you specific legal rights, and you may also have other rights which vary from state to state.

- 1) Some states do not allow limitations on how long an implied warranty lasts, so the above limitation may not apply to you.
- 2) Some states do not allow the exclusion or limitation of incidental or consequential damages, so the above limitation or exclusion may not apply to you.

*in spring put cement + furnace  
in seams*

