

FOR INSTALLERS AND SERVICE TECHNICIANS ONLY.



**PELLET
STOVE
SERVICE
MANUAL**

Sherwood Industries Ltd. Duplication of this document is prohibited. All rights reserved.

POP-093

TABLE OF CONTENTS

Introduction.....	4
Stove Specifications.....	5
Stove Controls.....	8
Timer Control Panel:.....	8
Circuit Board Control Panel - DHC 2000.....	9
Control Board Functions - DHC 4000 & 4100.....	10
Control Board Functions - DHC 4110.....	11
Control Board Functions - Omega.....	12
Control Board Functions - Daughter Generation I.....	14
Control Board Functions - Daughter Generation II.....	15
Control Board Lights - DHC 2000.....	15
Circuit Board Set-Up - DHC 2000.....	16
Circuit Board Set-Up - DHC 3000.....	17
Circuit Board Set-Up - DHC 4000.....	18
Circuit Board Pin Set-Up - Daughter Board.....	18
Stove Operation - Timer Control.....	19
Start-Up Sequence.....	19
Shut Down.....	19
Stove Operation - Circuit Board.....	20
DHC 2000 Start-Up Sequence (15 Minutes) - Manual Mode, Factory Setting.....	20
DHC 2000 Normal Operation - Manual Mode, Factory Setting.....	20
DHC 2000 Shut Down - Manual Mode, Factory Setting.....	20
DHC 2000 Start-Up Sequence (15 Minutes) - HIGH/LOW Mode, With Thermostat or Wall Switch.....	21
DHC 2000 Normal Operation - HIGH/LOW Mode, With Thermostat or Wall Switch.....	21
DHC 2000 Shut Down - HIGH/LOW Mode, With Thermostat or Wall Switch.....	22
DHC 2000 Start-Up Sequence (15 Minutes) - ON/OFF Mode, With Thermostat or Wall Switch.....	22
DHC 2000 Normal Operation - ON/OFF Mode, With Thermostat or Wall Switch.....	23
DHC 2000 Shut Down - ON/OFF Mode, With Thermostat or Wall Switch.....	23
DHC 4100 Start-Up Sequence (15 Minutes) - Manual Mode, Factory Setting.....	24
DHC 4100 Normal Operation - Manual Mode, Factory Setting:.....	24
DHC 4100 Shut Down - Manual Mode, Factory Setting:.....	24
DHC 4100 Start-Up Sequence (15 Minutes) - HIGH/LOW Mode, With Thermostat or Wall Switch.....	25
DHC 4100 Normal Operation - HIGH/LOW Mode, With Thermostat or Wall Switch.....	25
DHC 4100 Shut Down - HIGH/LOW Mode, With Thermostat or Wall Switch.....	26
DHC 4100 Start-Up Sequence (15 Minutes) - AUTO/OFF Mode, With Thermostat or Wall Switch.....	26
DHC 4100 Normal Operation - AUTO/OFF Mode, With Thermostat or Wall Switch.....	27
DHC 4100 Shut Down - AUTO/OFF Mode, With Thermostat or Wall Switch.....	27
DHC 4110 Start-Up Sequence (15 Minutes) - Manual Mode, Factory Setting.....	28
DHC 4110 Normal Operation - Manual Mode, Factory Setting.....	28
DHC 4110 Shut Down - Manual Mode, Factory Setting.....	28
DHC 4110 Start-Up Sequence (15 Minutes) - HIGH/LOW Mode, With Thermostat or Wall Switch.....	28
DHC 4110 Normal Operation - HIGH/LOW Mode, With Thermostat or Wall Switch.....	29
DHC 4110 Shut Down - HIGH/LOW Mode, With Thermostat or Wall Switch.....	29
DHC 4110 Start-Up Sequence (15 Minutes) - AUTO/OFF Mode, With Thermostat or Wall Switch.....	29
DHC 4110 Normal Operation - AUTO/OFF Mode, With Thermostat or Wall Switc.h.....	30
DHC 4110 Shut Down - AUTO/OFF Mode, With Thermostat or Wall Switch.....	30
DHC 4100 Program Operation Descriptions.....	30
DHC 4110 Program Operation Descriptions.....	31
The How To's For Troubleshooting.....	32
Suggested Tools List.....	32
Troubleshooting Warnings.....	32
How To By-Pass The Dial-A-Fire.....	33
How To By-Pass The Start-up Switch.....	33
How To By-Pass The Fan Controller.....	34

TABLE OF CONTENTS

How To By-Pass The 200°F Manual Reset.....	34
How To Lubricate The Convection Blower.....	35
How To Remove The Convection Blower.....	35
How To By-Pass The 160°F Fan Sensor.....	36
How To By-Pass The Vacuum Switch.....	36
How To Remove The Exhaust Blower Motor.....	37
How To By-Pass Exhaust Temperature Sensor/Switch.....	37
How To By-Pass The 120°F Ignitor Temperature Sensor/Switch.....	38
How To Measure Resistance Across The Dial-A-Fire.....	38
How To Apply Direct Power To The Auger Motor.....	39
How To Measure The Exhaust Blower Voltage.....	39
How To Measure The Vacuum Level Produced By The Exhaust Blower.....	40
How To Change Program on DHC 4100.....	40
How To Start Up Cycle Bypass on DHC 4100.....	40
Troubleshooting.....	41
The Stove Will Not Start.....	41
The Stove Will Not Operate When Hot.....	42
The 200°F (93°C) High Limit Temperature Sensor Has Tripped.....	44
The Convection Blower Will Not Function Normally.....	44
The Combustion (Exhaust) Motor Will Not Function Normally.....	45
The Auger Motor Will Not Function Normally.....	46
The Dial-a-fire Has No Effect On The Fire - Timer Control Only.....	47
The Auger Timer Will Not Function Normally - Timer Control Only.....	48
The Ignitor Will Not Work.....	48
The Stove Will Not Shut Off.....	49
Control Settings (Heat Level) Have No Effect On The Fire - Circuit Board Only.....	49
Circuit Board Fuses.....	50
The Auger Light Flashes But The Auger Does Not Turn At All.....	51
The Stove Keeps Going Out.....	51
The Auger Light Flashes But The Auger Does Not Turn At All.....	52
Light #2 On Heat Output Bar Flashing - Circuit Board Only.....	52
Light #3 On Heat Output Bar Flashing - Circuit Board Only.....	53
Flash Codes on DHC 4100.....	54
Flame Characteristics.....	55
Wiring Diagram.....	56
EF2 Timer Control.....	56
EF3 Timer Control.....	57
EF2, EF3, & EF4 Timer Control With Thermostat Interface.....	58
EF4.....	59
EF5 (Evolution) - Timer Control.....	60
EF5 (Evolution) & Mini - DHC 2000.....	61
Meridian Circuit Board - DHC 2000.....	62
Empress FS - DHC 2000.....	63
EF5 (Evolution), Mini, & Empress FS - DHC 3000, 4000, & 4100.....	64
Meridian - DHC 3000, 4000, & 4100.....	65
Empress FPI & Milan.....	66
Windsor.....	67
Maxx.....	68
M55-FS - DHC 4110.....	69
Omega.....	70
Components Of A Pellet Stove.....	71
Glossary.....	73
Warranty.....	74

INTRODUCTION

This is a service guide designed by SHERWOOD INDUSTRIES LTD.

We hope this manual will assist you to identify and correct operational concerns you might experience in all ENVIRO pellet stoves.

This service guide is designed for SERVICE TECHNICIANS AND INSTALLERS ONLY, as a certain level of technical understanding is required.

This guide is not designed for use by the homeowner.

If after using this service manual and following our recommendations, the problem still exists, dealers should contact their distributor for technical assistance.

Technical Division
Sherwood Industries Ltd.

STOVE SPECIFICATIONS

Table 1: Stove Specifications For Amperage, Wattages, And Magnehelic Readings.

MODEL	AMPERAGE	WATTAGE	RECOMMENDED Min. Continuous Pure Sine Wave Wattage	Magnehelic reading on High Fire	Magnehelic reading on Low Fire
EF2	3.9 Amp	450W	600W	.12 - .13	.09 - .10
EF2i	3.9 Amp	450W	600W	.12 - .13	.09 - .10
EF3Bi	4.5 Amp	520W	600W	.12 - .13	.09 - .10
EF4i	4.5 Amp	520W	600W	.11 - .12	.08 - .09
EF5-DIAL-A-FIRE	4.7 Amp	540W	600W	.11 - .12	.08 - .09
EF5-CIRCUIT BOARD	4.7 Amp	540W	600W	.10 - .11	.08 - .09
EMPRESS FS	4.1 Amp	500W	600W	.10 - .11	.08 - .09
MERIDIAN	4.6 Amp	520W	600W	.11 - .12	.08 - .09
MINI	4.1 Amp	500W	600W	.11 - .12	.08 - .09
WINDSOR (50-511 kit)	5.0 Amp	575W	600W	.11 - .12	.08 - .09
EMPRESS FPI	4.7 Amp	540W	600W	.12 - .13	.09 - .10
MILAN FPI	4.7 Amp	540W	600W	.12 - .13	.09 - .10
WINDSOR (50-994 kit)	5.0 Amp	575W	600W	.18 - .20	.14 - .16
MAXX	6.0 Amp	720W	850W	.14 - .16	.11 - .13
OMEGA	6.0 Amp	720W	850W	.14 - .16	.11 - .13

STOVE SPECIFICATIONS

Table 2: Stove Specifications For Voltages, And C.F.M.

MODEL	VOLTAGE TOLERANCE +/- 3 VOLTS										CONVECTION BLOWER C.F.M.
	C.B. COMBUSTION BLOWER VOLTAGE 1 - 5					C.B CONVECTION BLWR VOLTAGE 1 - 5					
	1	2	3	4	5	1	2	3	4	5	
EF2	Line V	Line V	Line V	Line V	Line V	69V		VARIABLE	Line V	Line V	160 C.F.M.
EF2i	Line V	Line V	Line V	Line V	Line V	69V		VARIABLE	Line V	Line V	160 C.F.M.
EF3Bi	Line V	Line V	Line V	Line V	Line V	69V		VARIABLE	Line V	Line V	160 C.F.M.
EF4i	69V		VARIABLE	Line V	Line V	69V		VARIABLE	Line V	Line V	150 C.F.M.
EF5-DIAL-A-FIRE	69V		VARIABLE	Line V	Line V	69V		VARIABLE	Line V	Line V	180 C.F.M.
EF5-CIRCUIT BOARD	76V	83V	90V	97V	Line V	80V	87V	97V	103V	Line V	180 C.F.M.
EMPRESS FS	76V	83V	90V	97V	Line V	75V	82V	89V	94V	Line V	110 C.F.M.
MERIDIAN	76V	83V	90V	97V	Line V	78V	84V	90V	96V	Line V	160 C.F.M.
MINI	76V	83V	90V	97V	Line V	82V	88V	95V	101V	Line V	105 C.F.M.
EMPRESS FPI	76V	83V	90V	97V	Line V	64V	70V	77V	84V	Line V	150 C.F.M.
WINDSOR	76V	83V	90V	97V	Line V	79V	85V	90V	97V	Line V	180 C.F.M.
MAXX	78V	93V	99V	104V	Line V	0	84V	91V	97V	Line V	455 C.F.M.
OMEGA	87V	95V	103V	108V	Line V	87V	96V	103V	110V	Line V	200 C.F.M.

STOVE SPECIFICATIONS

Table 3: Auger Feed Rates and ON/OFF Times.

MODEL	HEAT LEVEL	FEED RATE /sec. (Green lite to Green lite)	GREEN LITE /sec.		
			Off time	On time	
EF2/3	Low Blue	15.3 - 16.4	12.3 - 13.4	3.0	
	High Red	4.2 - 4.4	1.2 - 1.4	3.0	
ALL CIRCUIT BOARD MODELS (excluding Maxx, Omega)	1	11.5	8.5	3.0	
	2	9.06	6.06	3.0	
	3	7.07	4.07	3.0	
	4	5.09	2.09	3.0	
	5	4.07	1.07	3.0	
MAXX	A - MODE 70,000 BTU	1	21.0	18.0	3.0
		2	12.0	9.0	3.0
		3	8.0	5.0	3.0
		4	5.5	2.5	3.0
		5	4.5	1.5	3.0
	B - MODE 60,000 BTU	1	22.0	19.0	3.0
		2	12.0	9.0	3.0
		3	8.0	5.0	3.0
		4	6.0	3.0	3.0
		5	5.0	2.0	3.0
	C - MODE 50,000 BTU	1	24.0	21.0	3.0
		2	12.0	9.0	3.0
		3	8.5	5.5	3.0
		4	6.5	3.5	3.0
		5	5.5	2.5	3.0
OMEGA	PELLET	1	28.0	25.0	3.0
		2	15.0	12.0	3.0
		3	10.0	7.0	3.0
		4	7.0	4.0	3.0
		5	5.0	2.0	3.0
	MULTI FUEL	1	28.0	25.0	3.0
		2	19.0	16.0	3.0
		3	13.0	10.0	3.0
		4	10.0	7.0	3.0
		5	8.0	5.0	3.0

STOVE CONTROLS

TIMER CONTROL PANEL:

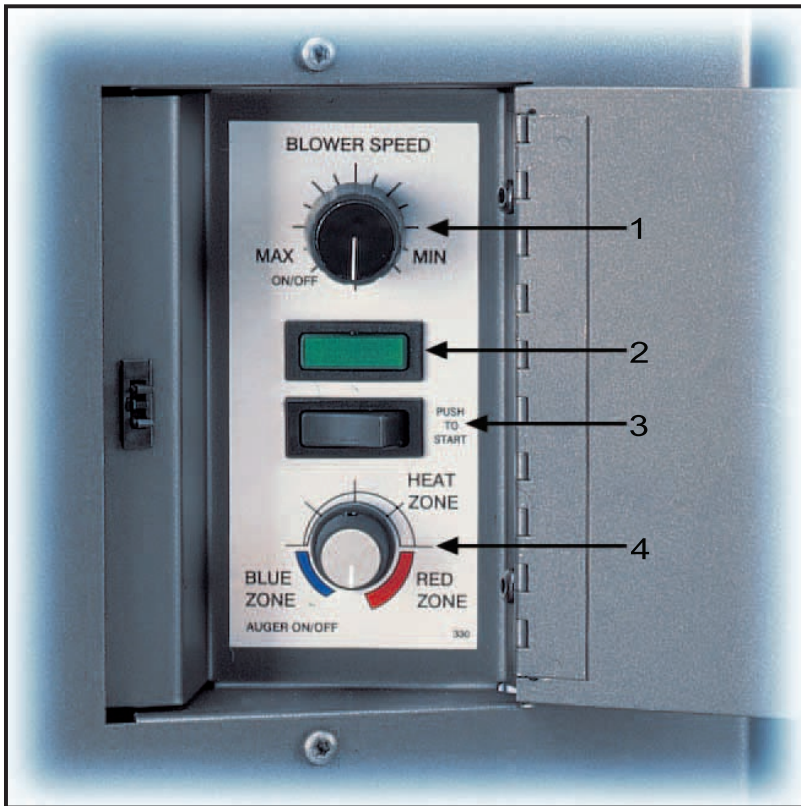

Figure 1: Dial-A-Fire control panel EF3, EF4, & EF5.

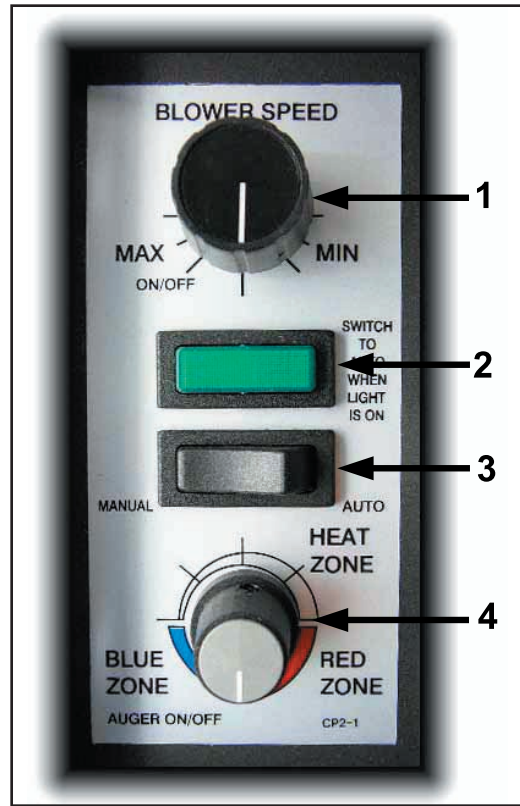

Figure 2: Dial-A-Fire control panel EF2.

- 1. CONVECTION BLOWER SPEED CONTROL (KNOB A):** By adjusting the knob you will vary the rate of airflow into the room by varying the speed of the convection blower. When you first start the stove, it should be placed in the "OFF" position in order to heat the unit as quickly as possible. Once the room has come up to temperature, the control may be set to a comfortable level.
- 2. AUGER LIGHT:** For the EF3/4/5 the flashing green light corresponds to the auger feed rate. For the EF2 it indicates unit is hot – switch unit to auto
- 3. START-UP SWITCH:** For the EF3/4/5 it switches the power "ON" by pushing the start-up switch once only. For the EF2 manually start the unit – then switch to auto when green light comes on. This allows the unit to shut off when the fire goes out.
- 4. Dial-a-fire HEAT OUTPUT (KNOB B):** This knob controls the amount of heat output. The dial has a scale with the **blue zone** representing the coolest setting of the stove, and the **red zone** representing the hottest setting. The scale on knob "B" represents a range, not exact at times or fuel quantities. Wood pellets of differing quality may affect the performance of the stove. If the stove has trouble operating at either end of its range, turn the heat output knob turn heat output knob up or down slightly. **SPECIAL NOTES:** The scale on the Dial-a-fire knob represents a range, not exact times.

STOVE CONTROLS

CIRCUIT BOARD CONTROL PANEL - DHC 2000:

- AUGER TRIM:** Used to change feed rates on LOW ONLY for poorer quality fuels. Push the Auger Trim button until the number 1 and 5 lights appear on the Heat Level Indicator. This will increase the feed rate to 4 seconds ON time Auger pulse. This is done only on LOW to allow the burning of poor quality fuels. Push the button until the number 1 and 4 lights appear, this will reduce the Auger On time to 2 second. This setting is for high-grade fuel only. Push the button until just the number 1 light is on, this is for a three (3) second on time (standard setting).

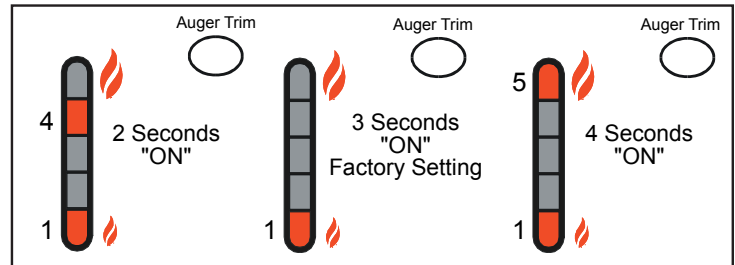

Figure 3: DHC 2000 Auger Trim And Heat Level Indicator.

- CONVECTION BLOWER CONTROL:** Used to turn the convection blower ON/OFF. Press this switch to turn the convection blower OFF. Leave the convection blower ON for peak efficiency. DHC 2000 - If the blower is left off, and the sensor located on the air jacket reaches 160°F (71°C), the convection blower will automatically come on HI speed to cool the unit. Press again to turn the blower on to the preset speed that corresponds to the heat level.
- AUGER PULSE LIGHT:** This light will flash in conjunction with the auger.
- MANUAL AUGER FEED:** If the unit runs out of fuel, this button can be used to “prime the auger system”. This button will turn off after 60 seconds and then must be released and pressed again. The auger returns to automatic when the switch is released.
- SYSTEM LIGHT:** Responsible for signaling the state of the control board. When the light is flashing during start-up, the stove is in an automatic start mode. When the light is solid, the Heat Level Setting can be altered.

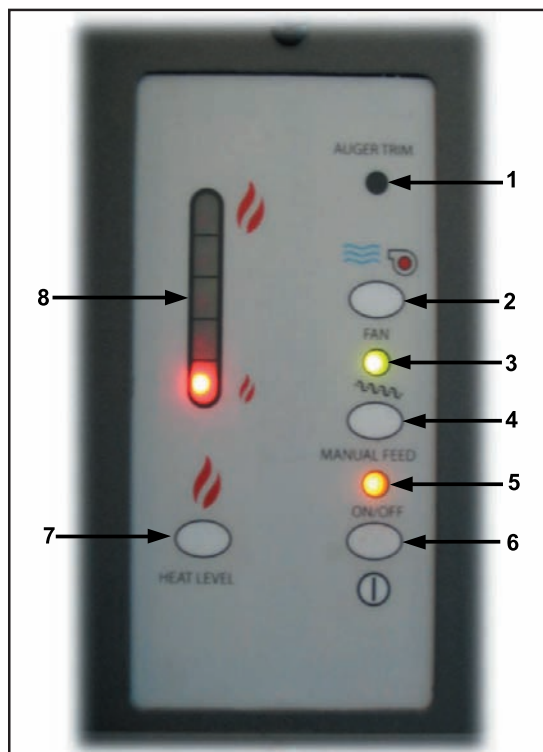

Figure 4: DHC 2000 Circuit Board Control Panel.

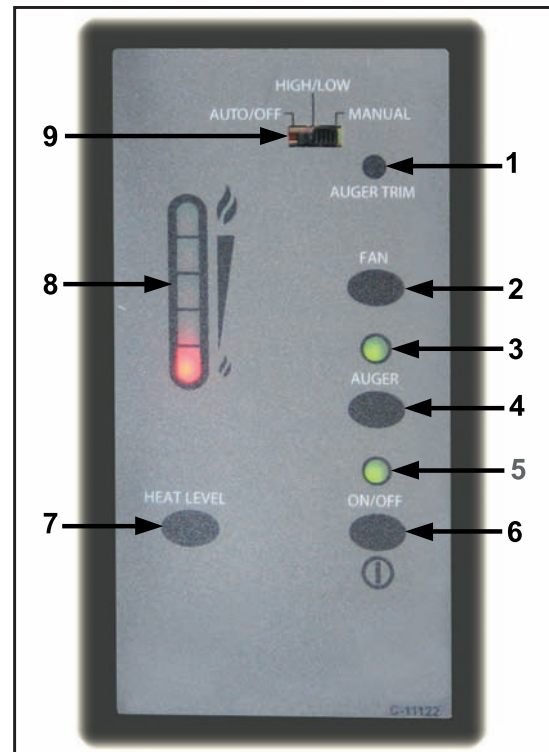

Figure 5: DHC 3000 Circuit Board Control Panel.

STOVE CONTROLS

- 6. ON/OFF BUTTON:** Used to turn the unit ON and OFF. Push this switch to start or stop the unit when the unit is operating in manual or HIGH/LOW thermostat mode (ON/OFF is automatic once the stove has been started once).
- 7. HEAT LEVEL ADJUSTMENT:** When pressed, will change the heat setting of the unit from low to high.
- 8. HEAT OUTPUT INDICATOR:** Shows the present heat output setting.
- 9. THERMOSTAT SWITCH (DHC 3000):** Used to set the unit's controls to one of three mode settings; manual, high/low, or auto/off.

CONTROL BOARD FUNCTIONS - DHC 4000 & 4100:

- 1. AUGER LIGHT:** This green light will flash in conjunction with the auger pulse.
- 2. MODE LIGHT:** Responsible for signaling the state of the control board. When the light is flashing the stove is in an automatic start mode or the thermostat has control of the unit. When the light is solid, the Heat Level Setting can be altered.
- 3. THERMOSTAT SWITCH:** Used to set the unit's controls to one of three mode settings; manual, high/low, or auto/off.
- 4. FEED RATE TRIM BUTTON:** Used to change the feed rate trims in ¼ second increments for all feed settings. When this button is pressed, all the lights will light up on the Heat Output Indicator except for the one that shows the current setting; the default setting is the number 4 light. To adjust the setting hold the Feed Rate Trim button down and press the Heat Level up or down buttons to adjust the setting.
- 5. COMBUSTION BLOWER TRIM BUTTON:** Used to change the Combustion Blower trims in 5 volt increments for all feed settings until it reaches line voltage. When this button is pressed, all the lights will light up on the Heat Output Indicator except for the one that shows the current setting; the default setting is the number 2 light. To adjust the setting hold the Combustion Blower Trim button down and press the Heat Level up or down buttons to adjust the setting.
- 6. ON/OFF BUTTON:** Used to turn the unit ON and OFF.
- 7. ROOM AIR FAN ON/OFF BUTTON:** Used to turn convection fan on or off. This button is inactive in some programs.
- 8. HEAT LEVEL ADJUSTMENT BUTTONS:** When pressed, will change the heat level setting of the unit up or down.
- 9. HEAT OUTPUT INDICATOR:** Shows the present heat output setting. The bottom is position #1 and the top is #5

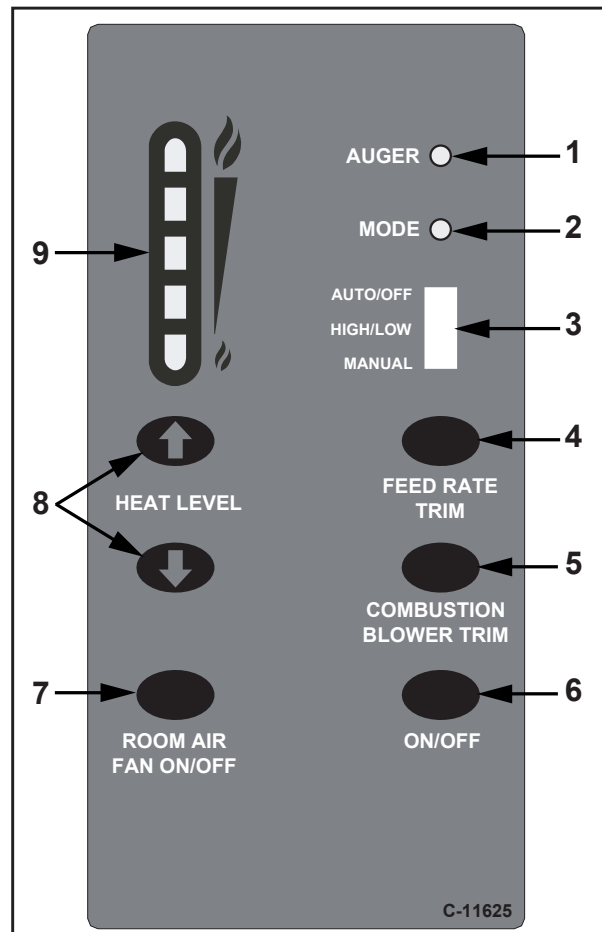

Figure 6: DHC 4000 & 4100 Circuit Board Control Panels.

STOVE CONTROLS

CONTROL BOARD FUNCTIONS - DHC 4110:

- 1. ON/OFF BUTTON:** Used to turn the unit ON and OFF manually.
- 2. COMBUSTION AIR TRIM BUTTON:** Increases or Decreases the Fan voltage by 2.5volts on all feed settings. When pressed all lights on Heat Level Indicator will come on except the one that is the set point. Hold Trim Button down and press the UP or DOWN Heat Level Arrow to adjust setting. #3 Light is the default setting.

Depending on Fuel quality Ignition problems may occur at higher altitudes, this can be resolved by trimming the Combustion Fan to a higher setting.

- 3. FUEL TYPE BUTTON:** Used to switch between fuel type modes; Pellet (for all qualities of wood pellets) and Multifuel (for all fuels including wood pellets). When set on Multifuel it will run at a reduced High Feed Rate with wood pellets.

NOTE: Fuel Type can only be changed when the unit is cold.

- 4. THERMOSTAT SWITCH:** Sets the unit's control mode; AUTO/OFF or HIGH/LOW (when using a Thermostat or Timer) or MANUAL.

- 5. FUEL TYPE LIGHTS:** Shows the present Fuel Type selected; Premium Pellets are Red, Regular Pellets are Green, and Multi-fuel is Yellow. The Light flashes during start-up, and when the Thermostat is in control of the Unit. The Light stops flashing when the Exhaust Sensor closes.

- 6. HEAT OUTPUT INDICATOR:** Shows the present Heat Level output setting and the Feed Trim while it is being adjusted. The bottom is position #1 and the top is #5

- 7. HEAT LEVEL ADJUSTMENT BUTTONS:** Changes the Heat Setting of the Unit from LO to HIGH. Press the Arrow Up button to increase Heat, and Arrow Down to decrease Heat.

- 8. FEED TRIM BUTTON:** Used in conjunction with the Heat Level Adjustment Buttons to adjust the Feed Trim. It can be increased by two (2) feed settings or it can be decreased by two (2) feed settings. The Feed Trim can only be adjusted one setting at a time.

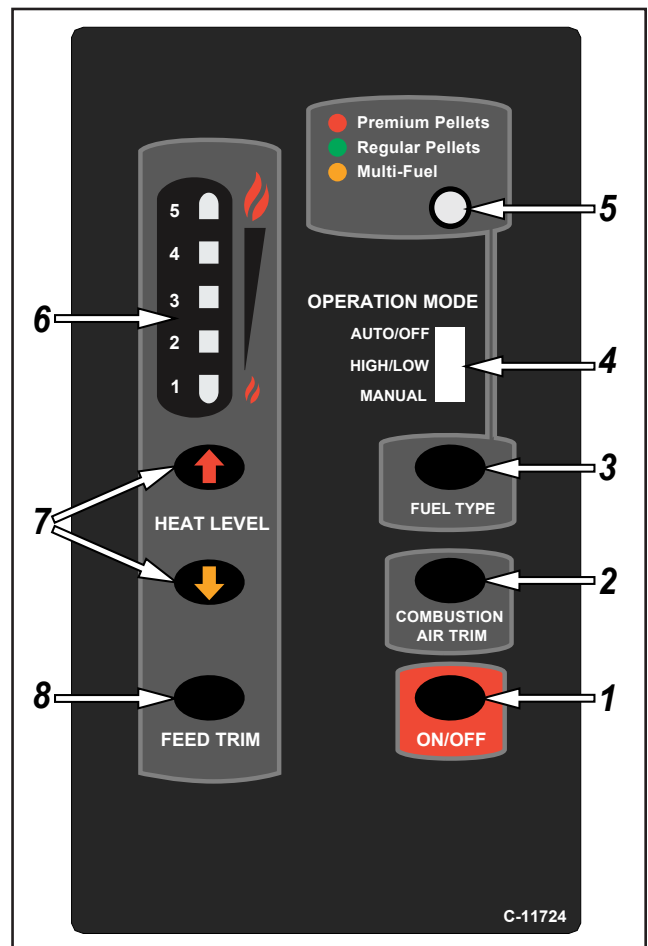

Figure 7: DHC 4110 Circuit Board Control Panel.

STOVE CONTROLS

CONTROL BOARD FUNCTIONS - OMEGA:

1. ON/OFF BUTTON: To turn on the stove, press the On/Off button. A start up sequence will begin where one of the fuel type indicator lights will turn on. This light will remain on until a proper fire is established.

Changing the heat level settings will move the heat level indicator light but will have no effect on the feed rate until the proper fire is established.

When the stove has established a proper fire the fuel type indicator light will flash in sequence with the fuel feed. The stove will operate on the last feed setting selected.

To turn off the stove, press the On/Off button and the stove will start its shut down sequence. You will not be able to alter any of the stoves operations during this shut down sequence. When the stove is cold it will turn off. This may take 10 to 15 minutes.

2. FUEL TYPE BUTTON: Used to switch between fuel type modes; Pellet (for all qualities of wood pellets) and Multifuel (for all fuels including wood pellets). When set on Multifuel it will run at a reduced High Feed Rate with wood pellets.

Switching to the Multi-fuel setting.

The Omega must be completely off to switch between the pellet feed and the multi-fuel feed. If you have been running the Omega and want to change from one fuel type to another you must turn the stove off and allow it to go through a full shut down cycle. Then you can change the fuel type by pressing the fuel type button. The Omega will switch between the pellet setting and the multi-fuel setting. An indicator light will show which setting is chosen, green for pellet and yellow for multi-fuel.

Trimming the multi-fuel settings.

You can increase or reduce the feed rates in the multi-fuel setting. Follow the procedures in STOVE CONTROLS; CONTROL BOARD FUNCTIONS - OMEGA item number 7.

Why change feed rates?

There are a wide variety of fuels available today. We give the operator the ability to trim the feed rates to allow the Omega to burn a wide variety of fuel types and sizes. In general the volume of fuel being fed through the auger is determined by the average size of the fuel. The smaller the average size the more fuel will be fed. Good wood pellets tend to be larger in size, averaging from 1/2" to 1 3/4" long. Lower quality pellets or alternate fuels like corn have smaller particle sizes ranging from 1/4" to 1/2".

Burning pellets in the alternate feed setting.

You can reduce the feed rate for pellets, lower than the lowest trimmed rate setting if desired. To do this, you can burn wood pellets on the multi-fuel feed setting. This will reduce the pellet feed by approximately 12%. You can then use the feed trim button to further alter the feed rate. This process allows the feed rate to be

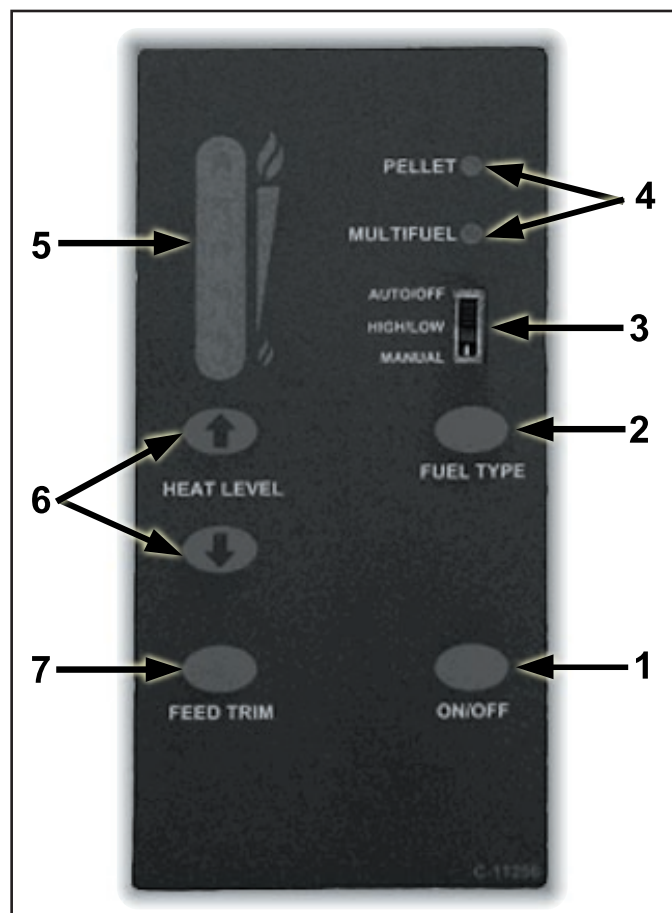

Figure 8: Omega Circuit Board Control Panel.

STOVE CONTROLS

altered by approximately 30% from its highest to its lowest setting giving the consumer tremendous control over their Omega.

Burning alternate fuels in the pellet setting.

It is not recommended to burn alternate fuels, or pellets with small particle sizes, on the pellet setting. Doing this may cause the Omega to run dirty. If you notice your glass getting black more quickly or the exhaust coming from the end of the flue pipe being dirty, then we recommend trimming the feed rate down or switching to the alternate fuel setting. This will reduce the feed rate and increase the air to fuel ratio. This will allow the Omega to run more efficiently and the stove will stay cleaner longer.

- 3. THERMOSTAT SWITCH:** The thermostat switch allows the consumer to operate the stove in 3 different control modes known as the "Tri-Mode Operating System"; AUTO/OFF or HIGH/LOW (when using a Thermostat or Timer) or MANUAL.

You can switch between the 3 settings while the stove is running.

The operations are as follows: -

Manual Mode - To increase or decrease the feed rate, simply press the heat level button up or down. There are 5 settings. A green indicator light will move to highlight the desired heat output.

Hi/Lo Mode - This mode is used when the stove is connected to a thermostat (not supplied). Turn the stove on as per the instructions above. When the stove has established a proper fire it will transfer some of the control of the stove to the thermostat.

When the thermostat is calling for heat the stove will cycle to the last heat output setting selected i.e. if the stove is set at #3 heat output setting the stove will operate on the 3# setting.

When the thermostat does not call for heat, the stove will cycle down to the #1 heat output setting. It will remain at the #1 setting until the thermostat calls for heat again.

To turn off the stove, press the On/Off button and the stove will start its shut down sequence. You will not be able to alter any of the stoves operations during this shut down sequence.

Auto / Off Mode - This mode is used when the stove is connected to a thermostat (not supplied). The stove will operate similarly to the Hi/Lo mode with one exception. If the stove cycles to the low setting and stays there for more than 30 minutes, the stove will automatically go into a shut down sequence. Any alteration to the heat settings during the shut down sequence will have no effect on the stoves operation.

When the shut down sequence is complete the stove hands control back to the thermostat. The stove will restart automatically if the thermostat calls for heat. Any alteration to the heat settings during the 30 minute start up sequence will have no effect on the stoves operation.

- 4. FUEL TYPE LIGHTS:** Shows the present Fuel Type selected; Pellet is green and Multifuel is yellow. The light flashes during start-up and stops flashing when the 49°C (120°F) exhaust temperature sensor switch closes.
- 5. HEAT OUTPUT INDICATOR:** Shows the present Heat Level output setting and the Feed Trim while it is being adjusted.
- 6. HEAT LEVEL ADJUSTMENT BUTTONS:** When pressed, they will change the heat setting of the unit from low to high. Press the up arrow button to increase heat or the down arrow to decrease the heat.
- 7. FEED TRIM BUTTON:** Used in conjunction with the Heat Level adjustment buttons to adjust the Feed Trim.
- The Feed Trim can only be adjusted one setting at a time. This button can also be used to "prime the auger system".
 - If you use the auger trim button it will affect all feed rate on all settings, 1 through 5 equally.

STOVE CONTROLS

- The auger trim button only affects the feed rate and not the combustion airflow. Therefore this will increase or decrease the air to fuel ratio.
- You can increase or decrease all feed rates by two increments or steps. Each feed rate change will increase or decrease the feed rate by approximately 5% for all settings 1 through 5.

Increasing the feed rate

- a) To increase the feed rate, push the auger trim button and the up button at the same time.
- b) The heat indicator light will flash at the current setting (e.g. if you are set on #3, that light will flash).
- c) Then push the auger trim up button again, the #4 light will flash. Then the light will return to #3.
- d) If you push the auger trim again, together with the up button, the #5 light will flash, then return to #3.
- e) If you have your heat indicator light set on #5 and you increase the feed rate, then only the #5 light will flash. The feed rates will increase.

Decreasing the feed rate

To decrease the feed rates, follow the above procedure a to c but use the down button.

If you have your heat indicator light set on #1 and decrease the feed rate, then only the #1 light will flash. The feed rates will decrease.

CONTROL BOARD FUNCTIONS - DAUGHTER GENERATION I:

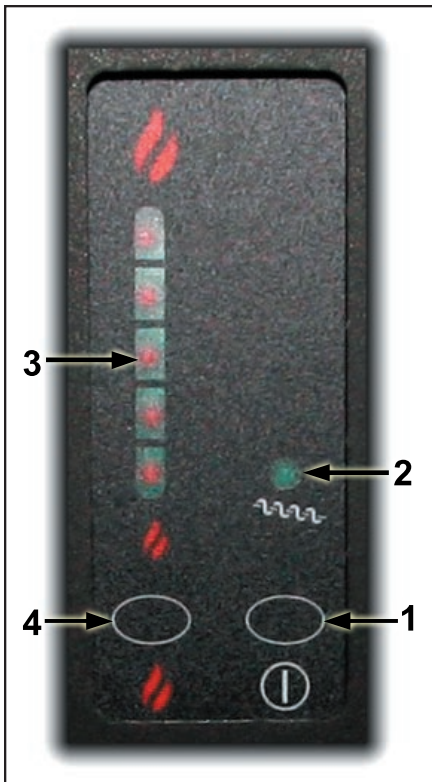

Figure 9: Daughter Circuit Board Control Panel - Generation I.

- 1. ON/OFF BUTTON:** Used to turn the unit ON and OFF.
- 2. AUGER PULSE LIGHT:** This light will flash in conjunction with the auger.
- 3. HEAT OUTPUT INDICATOR:** Shows the present heat output setting.
- 4. HEAT LEVEL ADJUSTMENT:** When pressed, will change the heat setting of the unit from low to high. The fan runs up and down with the heat setting.

Notes:

- The convection blower speed will vary automatically with the feed rate.
- Due to varying fuel qualities this pellet stove may not operate on lower Heat Level settings. If your unit goes out when on a low setting move the heat level up to a higher setting.
- The lowest and highest heat levels on this pellet stove are used for adjusting and accommodating for different pellet sizes and the varying energy produced by the fuels. The size of the pellets will change the volume of fuel being fed.
- The unit should be run at a setting where the least amount of cleaning of the burn pot is needed.

STOVE CONTROLS

CONTROL BOARD FUNCTIONS - DAUGHTER GENERATION II:

- 1. THERMOSTAT SWITCH:** Used to set the unit's controls to one of three mode settings; manual, high/low, or auto/off.
- 2. FEED RATE TRIM BUTTON:** Used to change the feed rate trims in ¼ second increments for all feed settings. When this button is pressed, all the light will light up on the Heat Output Indicator except for the one that shows the current setting; the default setting is the number 4 light. To adjust the setting hold the Feed Rate Trim button down and press the Heat Level up or down buttons to adjust the setting.
- 3. COMBUSTION BLOWER TRIM BUTTON:** Used to change the Combustion Blower trims in 5 volt increments for all feed settings until it reaches line voltage. When this button is pressed, all the light will light up on the Heat Output Indicator except for the one that shows the current setting; the default setting is the number 2 light. To adjust the setting hold the Combustion Blower Trim button down and press the Heat Level up or down buttons to adjust the setting.
- 4. ON/OFF BUTTON:** Used to turn the unit ON and OFF.
- 5. HEAT LEVEL ADJUSTMENT BUTTONS:** When pressed, will change the heat level setting of the unit up or down.
- 6. HEAT OUTPUT INDICATOR:** Shows the present heat output setting.

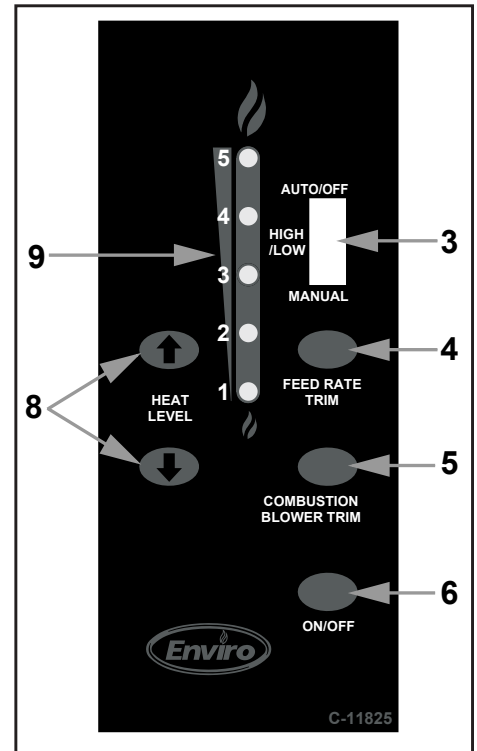

Figure 10: Daughter Circuit Board Control Panel - Generation II.

CONTROL BOARD LIGHTS - DHC 2000:

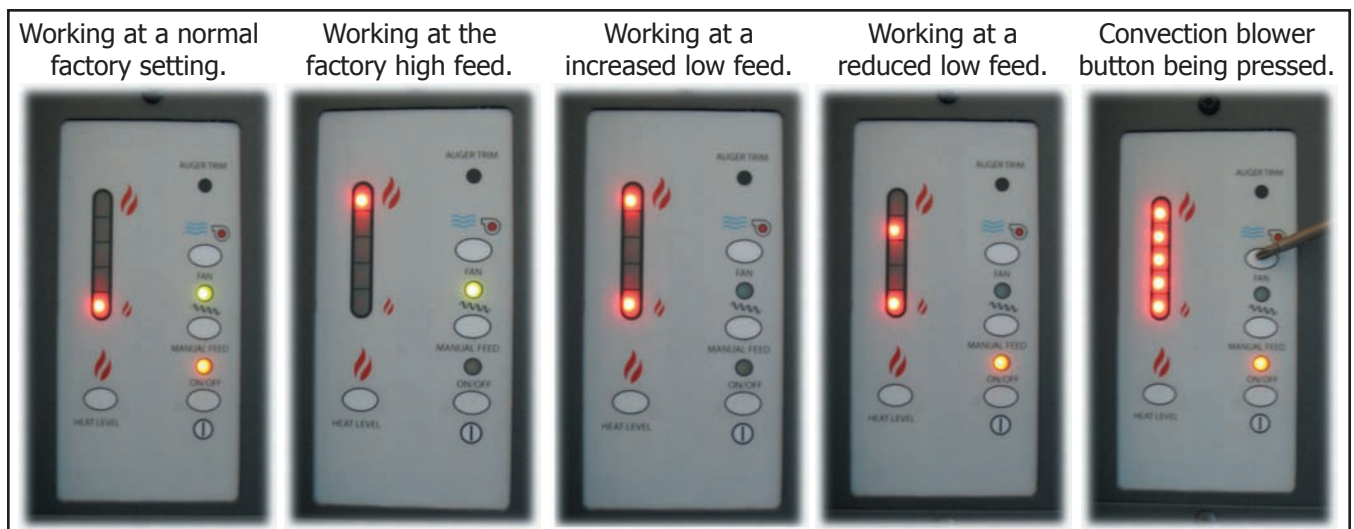

Figure 11: DHC 2000 Circuit Board Control Panel Light Examples.

STOVE CONTROLS

CIRCUIT BOARD SET-UP - DHC 2000:

The 2000 series boards are most recognizable by the 2 fuses and no slide switch.

HI / LOW OPERATION (Factory Setting): One pin is covered, as shown as 'A' in Figure 10. When the jumper J9 is not jumped then the control board is in a HI / LOW mode operation. If the unit has been placed in the HI / LOW mode, the unit will be taken to a low or idle setting when the thermostat is not calling for heat. When the thermostat calls for heat, the unit will go to the setting that is displayed on the control board Heat Indicator. If the heating load is not great enough when the stove is on low, the exhaust temperature switch will turn the stove off.

ON / OFF OPERATION: Both pins are covered, as shown as 'B' in Figure 10. If the control board is placed with J9 jumped then the control board is in a ON / OFF mode of operation. In the ON /OFF thermostat mode, when the thermostat calls for heat, the unit will go through an ignition sequence and light the stove. Once lit the unit will operate at the selected setting displayed on the control board Heat Output Indicator. Once the thermostat stops calling for heat, the unit will stop feeding pellets and begin its shut down sequence until cold then turn off.

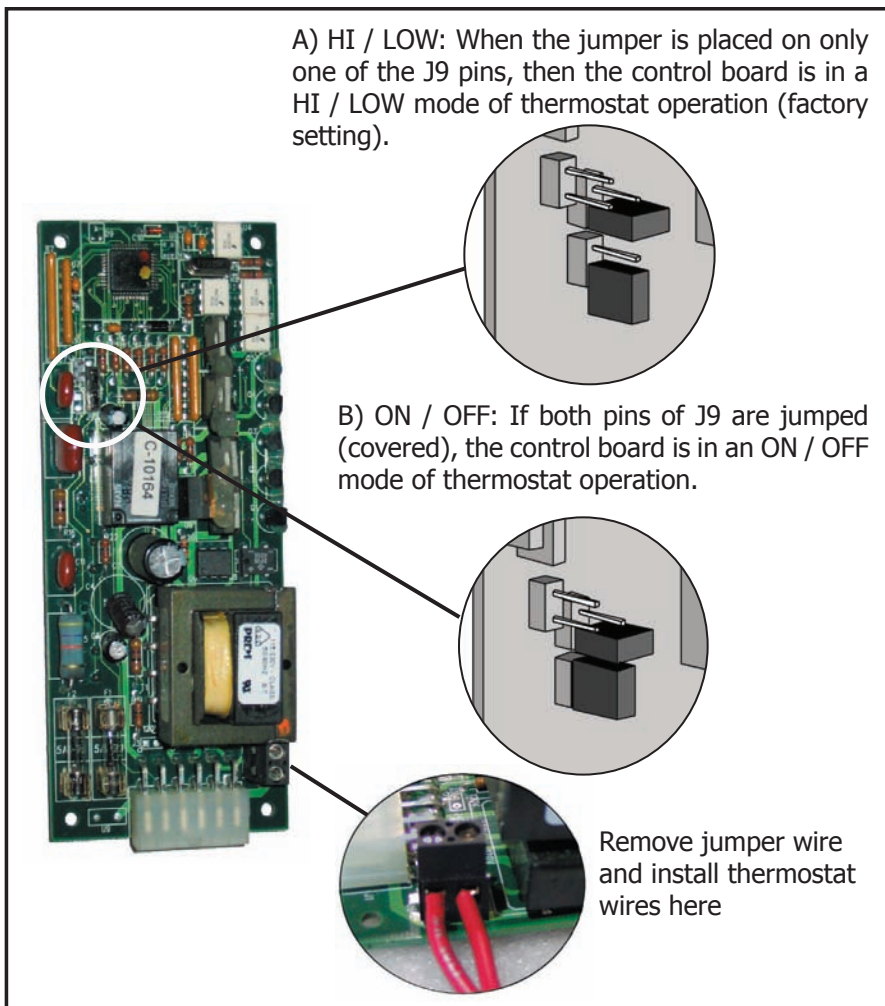

Figure 12: Setting the Thermostat mode Pins on DHC 2000 Board.

1. Install the Low Voltage Thermostat (maximum 24V) in a location that is not too close to the unit but will effectively monitor the desired area to be heated.
2. Open the right cab side to expose thermostat wires and disconnect. Install 18 gauge (see WIRING DIAGRAM section) or heavier wire through the grommet in the back, from the stove to the thermostat. Connect thermostat wires to red wires provided or remove if desired.
3. To set the thermostat jumper to the desired mode, remove the two (2) screws holding the circuit board control panel in place. Lower the board and pull out to change jumper.

STOVE CONTROLS

CIRCUIT BOARD SET-UP - DHC 3000:

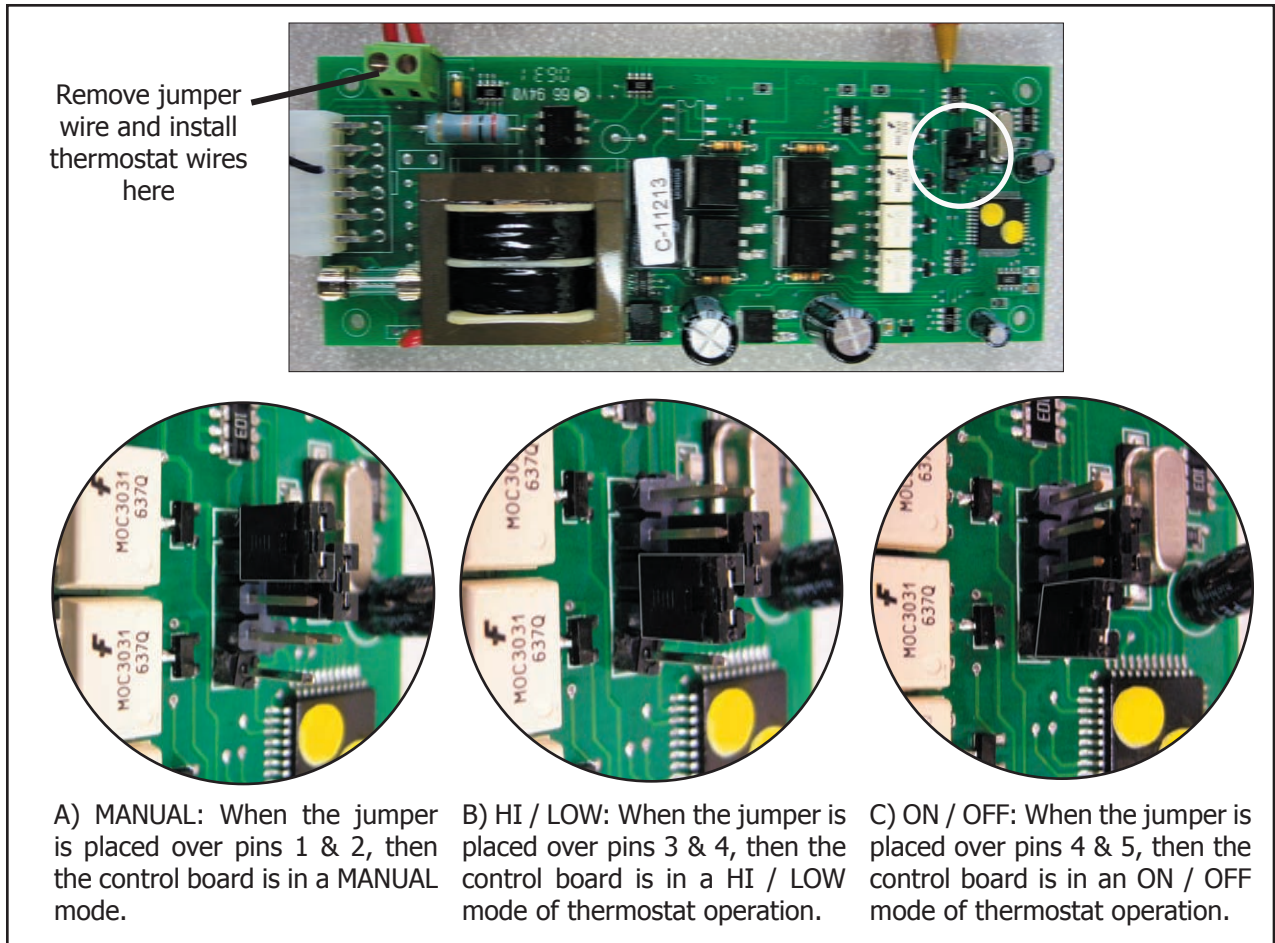

Figure 13: Setting the Thermostat mode Pins on DHC 3000 Board Generation I.

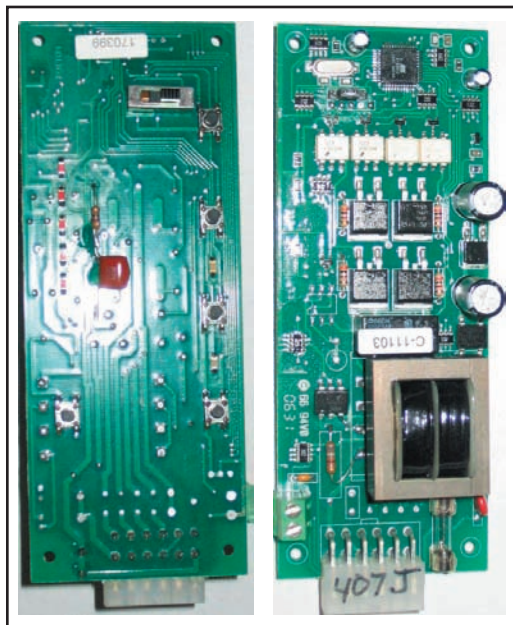

Figure 14: Front & Back of the DHC 3000 Board Generation II.

DHC 3000 Generation I - This board looks like the standard 3000 series board (Generation II) but it does not have the slide switch on the front; it has a second set of jumper pins on the back for the thermostat setting (see Figure 11). This board can be used to replace the DHC 2000 board.

DHC 3000 Generation II - This board has a horizontal slide switch on the front and only one (1) fuse (see Figure 12). Do not adjust the pins on the back of the Generation II board.

STOVE CONTROLS

CIRCUIT BOARD SET-UP - DHC 4000:

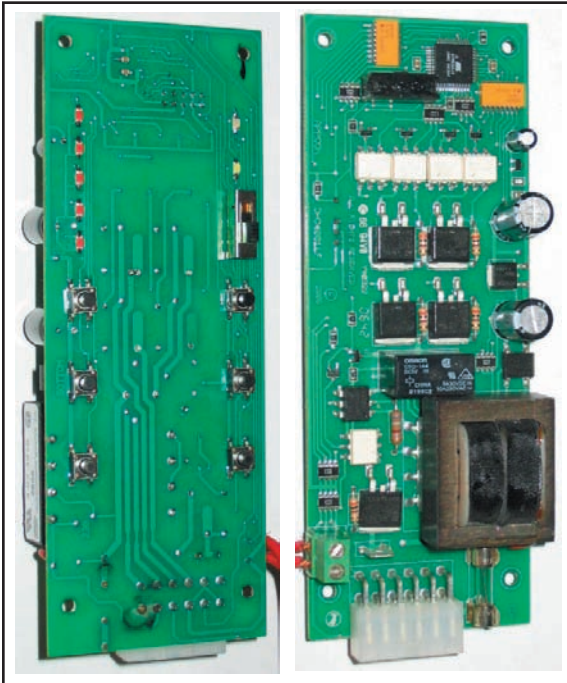

Figure 15: Front & Back of the DHC 4000 Board.

The DHC 4000 board has a vertical slide switch, one fuse and second multi pin connector for setting feed rates.

Circuit Board Pin Set-Up for Maxx BTU Inputs: This is the jumper pin location for the different BTU inputs for the Maxx pellet stove. The location of the jumper pin box is located at the upper left hand corner of the back of the circuit board (see Figure 14 below 60,000 BTU location)

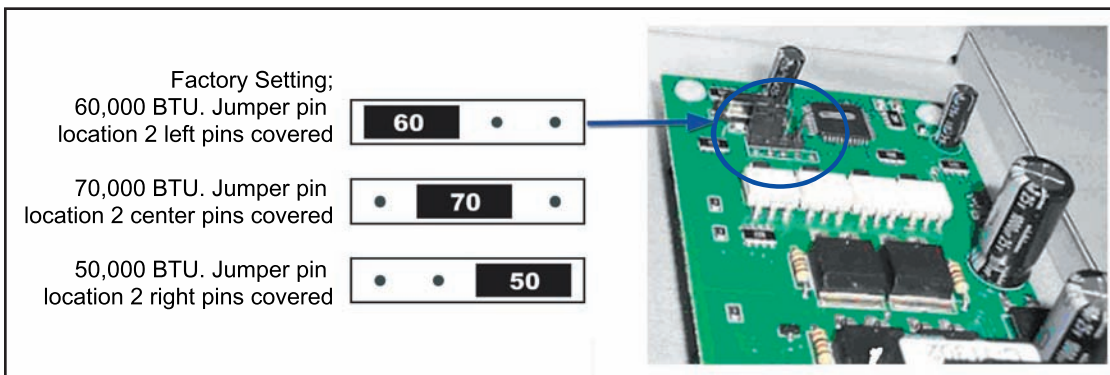

Figure 16: Setting the BTU Input Pins on DHC 4000 Board For the Maxx.

CIRCUIT BOARD PIN SET-UP - DAUGHTER BOARD:

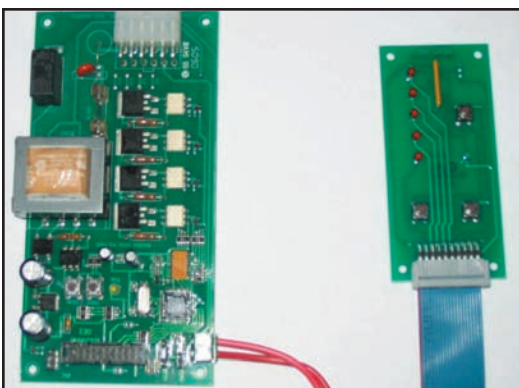

Figure 17: Mother & Daughter Boards.

The mother board is wider than the DHC boards and has no LEDs on the front. It uses pin outs instead of a slide switch for the thermostat selection

STOVE OPERATION - TIMER CONTROL

START-UP SEQUENCE:

1. Switch the power "ON" by pushing the start-up switch once only.
2. Turn the dial-a-fire knob to the 12 o'clock position. **(Lower grade pellets may need a higher setting on the feed rate). NOTE:** Unit will take longer to light if the hopper has been completely emptied or is the first fire up.
3. Wait until the fire is established, then turn dial-a-fire knob to the desired heat output. The stove may not be able to stay burning in the BLUE ZONE if poor quality wood pellets are being used. Adjust the slider-damper to the appropriate setting.
4. If the stove should shut off after fifteen (15) minutes and there is still a fire in the firebox – press the start-up switch once more. If the fire went out, return to step 2 and re-light the stove.

SPECIAL NOTES:

The convection blower may cycle to high automatically depending on the setting of knobs "A" and "B". This is a normal safety feature of the unit.

Wood pellets of differing quality may affect the performance of the stove. If the stove has trouble operating at either end of its range, turn the heat output knob forward or back slightly.

SHUT DOWN:

To turn your stove off, simply turn the HEAT OUTPUT knob ("Knob B") counter-clockwise until the knob clicks to the "OFF" position. This will stop the feed of pellets.

The blowers will continue to run and cool the stove. When cool enough, the stove will shut down.

DO NOT unplug unit while combustion fan is operating; this may lead to smoke escaping from the stove.

STOVE OPERATION - CIRCUIT BOARD

DHC 2000 START-UP SEQUENCE (15 MINUTES) - MANUAL MODE, FACTORY SETTING:

NOTE: No Thermostat or Wall Switch

1. Push the ON/OFF button to start. The stove may take up to 30 seconds to establish firebox vacuum.
2. The ON/OFF light turns on solid.
3. The ON/OFF light starts to flash after the vacuum sensor has closed (approximately 15 seconds).
 - The Auger Light will flash with each pulse of the auger (the auger feed rate is pre-programmed during start-up). The auger light flashes:
 - 3 seconds ON
 - 8 seconds OFF
5. The combustion blower comes on at full speed.
- 6
 - a. The ignitor comes on.
 - b. The convection blower stays off.
 - c. The heat level indicator will show the heat level that the stove will run at after start-up.
 - d. The operator has no control over the start-up sequence. The operator can press and hold the manual feed button to run the auger continuously for 60 seconds and then will have to press again for another 60 seconds. The operator can also pre-set the heat output setting for operation. When the unit reaches operating temperature the heat output will go to that setting.
- 7
 - a. The unit should light after 5 to 12 minutes.
 - b. Once the 120°F (49°C) exhaust temperature sensor closes, the convection blower will come on.
8. Fifteen minutes after pushing the start button, the ON/OFF light will change to solid. This signals that the unit is at operating temperature.

DHC 2000 NORMAL OPERATION - MANUAL MODE, FACTORY SETTING:

The operator can now set the heat output, low feed trim, and whether the convection blower is ON or OFF (depending on model).

The convection blower can be turned OFF by depressing the convection blower control button.(MERIDIAN ONLY: When the air jacket reaches 160°F (71°C) the convection blower will come on high, cooling the unit). For the best efficiency, the convection blower should be left on at all times.

When operating on LOW HEAT LEVEL, the feed rate can be adjusted, using the auger trim, for different quality fuels.

Please note: When the heat output is changed, the combustion blower and convection blower speed change as well.

DHC 2000 SHUT DOWN - MANUAL MODE, FACTORY SETTING:

1. Push ON/OFF button to turn stove off.
2. All the lights will turn off
3. The auger will stop feeding
4. The combustion blower goes to full speed until the exhaust temperature sensor opens, stopping all motors.

STOVE OPERATION - CIRCUIT BOARD

DHC 2000 START-UP SEQUENCE (15 MINUTES) - HIGH/LOW MODE, WITH THERMOSTAT OR WALL SWITCH:

Thermostat contacts open (it is satisfied) or closed (it is calling for heat) at time of start-up.

1. Push the ON/OFF button to start. The stove may take up to 30 seconds to establish firebox vacuum.
2. The ON/OFF light turns on solid.
3. The ON/OFF light starts to flash after the vacuum sensor has closed (approximately 15 seconds).
 - The Auger Light will flash with each pulse of the auger (the auger feed rate is pre-programmed during start-up). The auger light flashes:
 - 3 seconds ON
 - 8 seconds OFF
5. The combustion blower comes on at full speed.
- 6
 - a. The ignitor comes on.
 - b. The convection blower stays off.
 - c. The heat level indicator will show the heat level that the stove will run at after start-up.
 - d. The operator has no control over the start-up sequence. The operator can press and hold the manual feed button to run the auger continuously for 60 seconds then must be pressed again for another 60 seconds. The operator can also pre-set the heat output setting for operation. When the unit reaches operating temperature the heat output will go to that setting.
- 7
 - a. The unit should light after 5 to 12 minutes.
 - b. Once the 120°F (49°C) exhaust temperature sensor closes, the convection blower will come on.
8. Fifteen minutes after pushing the start button, the ON/OFF light will change to solid. This signals that the unit is at operating temperature.

Note: The circuit board can only be turned off during start-up if vacuum has been established and the thermostat contacts are closed. The ON/OFF light will continue flashing

DHC 2000 NORMAL OPERATION - HIGH/LOW MODE, WITH THERMOSTAT OR WALL SWITCH:

Thermostat contacts are closed (it is calling for heat).

The ON/OFF light is solid. The operator can now set the heat output, low feed trim, and whether the convection blower is ON or OFF.

(Depending on the model) The convection blower can be turned OFF by depressing the convection blower control button. When the air jacket reaches 160°F (71°C) the convection blower will come on high, cooling the unit. For the best efficiency and to prevent cycling, the convection blower should be left on at all times.

When operating on LOW HEAT LEVEL, the feed rate can be adjusted, using the auger trim, for different quality fuels.

Please note: When the heat output is changed, the combustion blower and convection blower speed change as well.

Thermostat contacts are open (it is satisfied).

The ON/OFF light starts flashing.

All functions drop to LOW speed. Combustion blower speed, convection blower speed and heat output all change to LOW together.

Operator has no control over the Heat output, but can control the Low Feed Trim and Convection Blower ON/OFF.

STOVE OPERATION - CIRCUIT BOARD

DHC 2000 SHUT DOWN - HIGH/LOW MODE, WITH THERMOSTAT OR WALL SWITCH:

Thermostat contacts are closed (it is calling for heat).

1. Push ON/OFF button to turn stove off.
2. All the lights will turn off
3. The auger will stop feeding
4. The combustion blower goes to full speed until the exhaust temperature sensor opens, stopping all motors.

Thermostat contacts are open (it is satisfied).

1. Push ON/OFF button to turn stove off.
2. The ON/OFF light continues to flash.
3. Auger stops feeding.
4. Combustion blower goes to full speed until exhaust sensor opens and blower stops.
5. The ON/OFF light will continue to flash (unless power is disconnected).

DHC 2000 START-UP SEQUENCE (15 MINUTES) - ON/OFF MODE, WITH THERMOSTAT OR WALL SWITCH:

Thermostat contacts closed (it is calling for heat) at time of start-up.

1. Push the ON/OFF button to start. The stove may take up to 30 seconds to establish firebox vacuum.
2. The ON/OFF light turns on solid.
3. The ON/OFF light starts to flash after the vacuum sensor has closed (approximately 15 seconds).
 - The Auger Light will flash with each pulse of the auger (the auger feed rate is pre-programmed during start-up). The auger light flashes:
 - 3 seconds ON
 - 8 seconds OFF
5. The combustion blower comes on at full speed.
- 6
 - a. The ignitor comes on.
 - b. The convection blower stays off.
 - c. The heat level indicator will show the heat level that the stove will run at after start-up.
 - d. The operator has no control over the start-up sequence. The operator can press and hold the manual feed button to run the auger continuously for 60 seconds then must be pressed again for another 60 seconds. The operator can also pre-set the heat output setting for operation. When the unit reaches operating temperature the heat output will go to that setting.
- 7
 - a. The unit should light after 5 to 12 minutes.
 - b. Once the 120°F (49°C) exhaust temperature sensor closes, the convection blower will come on.
8. Fifteen minutes after pushing the start button, the ON/OFF light will change to solid. This signals that the unit is at operating temperature.

Note: If the thermostat contacts are opened (it is satisfied) during start-up the circuit board and all motors turn OFF and ON/OFF light remains flashing.

Thermostat contacts are open (it is satisfied) when the ON/OFF button is pressed.

The circuit board will not turn on.

STOVE OPERATION - CIRCUIT BOARD

DHC 2000 NORMAL OPERATION - ON/OFF MODE, WITH THERMOSTAT OR WALL SWITCH:

Thermostat contacts are closed (it is calling for heat).

If the stove is OFF then the unit will start the start-up sequence.

After the 15 minutes, the operator can now change the heat output, low feed trim, and whether the convection blower is ON or OFF (depending on the model).

The convection blower can be turned OFF by depressing the convection blower control button. When the air jacket reaches 160°F (71°C) the convection blower will come on high, cooling the unit. For the best efficiency and to prevent cycling, the convection blower should be left on at all times.

When operating on LOW HEAT LEVEL, the feed rate can be adjusted, using the auger trim, for different quality fuels.

If the unit was in the LOW mode when the thermostat closes then the controls will change to the Manual mode.

Please note: When the heat output is changed, the combustion blower and convection blower speed change as well.

Thermostat contacts are open (it is satisfied).

1. The stove will shut down after 30 minutes on LOW.
2. All lights turn off.
3. Auger stops feeding.
4. Combustion blower goes to full speed until exhaust sensor opens and blower stops.

DHC 2000 SHUT DOWN - ON/OFF MODE, WITH THERMOSTAT OR WALL SWITCH:

Thermostat contacts are closed (it is calling for heat).

The stove will not shut off.

If you push ON/OFF button the circuit board will go through a start-up sequence (see START-UP SEQUENCE (15 MINUTES) - ON/OFF MODE, WITH THERMOSTAT OR WALL SWITCH).

Thermostat contacts are open (it is satisfied).

1. Push ON/OFF button to turn stove off, turn the thermostat down, or off
2. All lights turn off.
3. Auger stops feeding.
4. Combustion blower goes to full speed until exhaust sensor opens and blower stops.

STOVE OPERATION - CIRCUIT BOARD

DHC 4100 START-UP SEQUENCE (15 MINUTES) - MANUAL MODE, FACTORY SETTING:

NOTE: No Thermostat or Wall Switch - Manual Control Only

1. Push the ON/OFF button to start. The stove may take up to 30 seconds to establish firebox vacuum.
2. The Auger Light will flash with each pulse of the auger (the auger feed rate is pre-programmed during start-up).
3. The combustion blower comes on at full speed.
4.
 - a. The ignitor comes on.
 - b. The convection blower stays off.
 - c. The heat level indicator will show the heat level that the stove will run at after start-up.
 - d. The operator has no control over the start-up sequence. The operator can press and hold the manual feed button to run the auger continuously for 60 seconds and then will have to press again for another 60 seconds. The operator can also pre-set the heat output setting for operation. When the unit reaches operating temperature the heat output will go to that setting.
5.
 - a. The unit should light after 5 to 12 minutes.
 - b. Once the 120°F (49°C) exhaust temperature sensor closes, the convection blower will come on.
6. Fifteen minutes after pushing the start button, the Mode light will change to solid. This signals that the unit is at operating temperature and control is returned to the user.
7. The Auger Light will continue to flash to the corresponding Heat Level setting. The Heat Level Indicator will show the Heat Level that the stove will run at after start-up and can be adjusted but the change will not take affect until the start -up has finished.
8. The convection blower (room air blower) will turn on.

DHC 4100 NORMAL OPERATION - MANUAL MODE, FACTORY SETTING:

The operator can now set the heat output, low feed trim, and whether the convection blower is ON or OFF (depending on model).

The combustion fan trim changes exhaust voltage incrementally on all heat levels. When this button is pressed, all the lights come on except the one that is the set point. This will indicate what setting it is on before adjustment. Hold the button down and press the up or down arrow to adjust the setting. Depending on the model, the convection blower can be turned OFF by depressing the convection blower control button. For the best efficiency, the convection blower should be left on at all times.

Feed trim changes 'ON' time in 0.25 sec. increments for each feed settings. Position #4 is the factory default setting, there is one (1) setting up and three (3) settings down. When this button is pressed all the lights come on except the one that is the set point. This will indicate what setting it is on before adjustment. Hold 'Feed Rate Trim' button down and press the up or down arrow to adjust setting. Trim settings are still maintained after loss of power.

DHC 4100 SHUT DOWN - MANUAL MODE, FACTORY SETTING:

1. Push ON/OFF button to turn stove off.
2. All the lights will turn off
3. The auger will stop feeding
4. The combustion blower goes to full speed until the exhaust temperature sensor opens, stopping all motors.

STOVE OPERATION - CIRCUIT BOARD

DHC 4100 START-UP SEQUENCE (15 MINUTES) - HIGH/LOW MODE, WITH THERMOSTAT OR WALL SWITCH:

Thermostat contacts open (it is satisfied) or closed (it is calling for heat) at time of start-up.

1. Push the ON/OFF button to start. The stove may take up to 30 seconds to establish firebox vacuum.
2. The Auger Light will flash with each pulse of the auger (the auger feed rate is pre-programmed during start-up).
3. The combustion blower comes on at full speed.
4.
 - a. The ignitor comes on.
 - b. The convection blower stays off.
 - c. The heat level indicator will show the heat level that the stove will run at after start-up.
 - d. The operator has no control over the start-up sequence. The operator can press and hold the manual feed button to run the auger continuously for 60 seconds and then will have to press again for another 60 seconds. The operator can also pre-set the heat output setting for operation. When the unit reaches operating temperature the heat output will go to that setting.
5.
 - a. The unit should light after 5 to 12 minutes.
 - b. Once the 120°F (49°C) exhaust temperature sensor closes, the convection blower will come on.
6. Fifteen minutes after pushing the start button, the Mode light will change to solid. This signals that the unit is at operating temperature and control is returned to the user.
7. The Auger Light will continue to flash to the corresponding Heat Level setting. The Heat Level Indicator will show the Heat Level that the stove will run at after start-up and can be adjusted but the change will not take affect until the start -up has finished.
8. The convection blower (room air blower) will turn on.

Note: The circuit board can only be turned off during start-up if vacuum has been established and the thermostat contacts are closed. The MODE light will continue flashing

DHC 4100 NORMAL OPERATION - HIGH/LOW MODE, WITH THERMOSTAT OR WALL SWITCH:

The unit will cycle between set heat level and low as the thermostat calls for heat.

Thermostat contacts are closed (it is calling for heat).

The operator can now set the heat output, low feed trim, and whether the convection blower is ON or OFF (depending on model).

The combustion fan trim changes exhaust voltage incrementally on all heat levels. When this button is pressed, all the lights come on except the one that is the set point. This will indicate what setting it is on before adjustment. Hold the button down and press the up or down arrow to adjust the setting. Depending on the model, the convection blower can be turned OFF by depressing the convection blower control button. For the best efficiency, the convection blower should be left on at all times.

Feed trim changes 'ON' time in 0.25 sec. increments for each feed settings. Position #4 is the factory default setting, there is one (1) setting up and three (3) settings down. When this button is pressed all the lights come on except the one that is the set point. This will indicate what setting it is on before adjustment. Hold 'Feed Rate Trim' button down and press the up or down arrow to adjust setting. Trim settings are still maintained after loss of power.

STOVE OPERATION - CIRCUIT BOARD

Thermostat contacts are open (it is satisfied).

The MODE light starts flashing.

The HEAT LEVEL and Fans will drop down to the LOW setting until the thermostat contacts close again.

*The LOW heat setting can be adjusted for different fuel qualities The stove will come back to the previous HEAT LEVEL setting when the thermostat contacts close again.

Operator has no control over the Heat output, but can control the Low Feed Trim and Convection Blower ON/OFF.

DHC 4100 SHUT DOWN - HIGH/LOW MODE, WITH THERMOSTAT OR WALL SWITCH:

1. Push ON/OFF button to turn stove off.
2. All the lights will turn off
3. The auger will stop feeding
4. The combustion blower goes to full speed until the exhaust temperature sensor opens, stopping all motors.

DHC 4100 START-UP SEQUENCE (15 MINUTES) - AUTO/OFF MODE, WITH THERMOSTAT OR WALL SWITCH:

Thermostat contacts closed (it is calling for heat) at time of start-up.

1. Push the ON/OFF button to start. The stove may take up to 30 seconds to establish firebox vacuum.
2. The Auger Light will flash with each pulse of the auger (the auger feed rate is pre-programmed during start-up).
3. The combustion blower comes on at full speed.
4.
 - a. The ignitor comes on.
 - b. The convection blower stays off.
 - c. The heat level indicator will show the heat level that the stove will run at after start-up.
 - d. The operator has no control over the start-up sequence. The operator can press and hold the manual feed button to run the auger continuously for 60 seconds and then will have to press again for another 60 seconds. The operator can also pre-set the heat output setting for operation. When the unit reaches operating temperature the heat output will go to that setting.
5.
 - a. The unit should light after 5 to 12 minutes.
 - b. Once the 120°F (49°C) exhaust temperature sensor closes, the convection blower will come on.
6. Fifteen minutes after pushing the start button, the Mode light will change to solid. This signals that the unit is at operating temperature and control is returned to the user.
7. The Auger Light will continue to flash to the corresponding Heat Level setting. The Heat Level Indicator will show the Heat Level that the stove will run at after start-up and can be adjusted but the change will not take affect until the start -up has finished.
8. The convection blower (room air blower) will turn on.

Note: If the thermostat contacts are opened (it is satisfied) during start-up the circuit board and all motors turn OFF and MODE light remains flashing.

Thermostat contacts are open (it is satisfied) when the ON/OFF button is pressed.

The circuit board will not turn on.

STOVE OPERATION - CIRCUIT BOARD

DHC 4100 NORMAL OPERATION - AUTO/OFF MODE, WITH THERMOSTAT OR WALL SWITCH:

Thermostat contacts are closed (it is calling for heat).

If the stove is OFF then the unit will start the start-up sequence (see DHC 4100 START-UP SEQUENCE (15 MINUTES) - ON/OFF MODE, WITH THERMOSTAT OR WALL SWITCH).

The operator can now set the heat output, low feed trim, and whether the convection blower is ON or OFF (depending on model).

The combustion fan trim changes exhaust voltage incrementally on all heat levels. When this button is pressed, all the lights come on except the one that is the set point. This will indicate what setting it is on before adjustment. Hold the button down and press the up or down arrow to adjust the setting. Depending on the model, the convection blower can be turned OFF by depressing the convection blower control button. For the best efficiency, the convection blower should be left on at all times.

Feed trim changes 'ON' time in 0.25 sec. increments for each feed settings. Position #4 is the factory default setting, there is one (1) setting up and three (3) settings down. When this button is pressed all the lights come on except the one that is the set point. This will indicate what setting it is on before adjustment. Hold 'Feed Rate Trim' button down and press the up or down arrow to adjust setting. Trim settings are still maintained after loss of power.

Please note: When the heat output is changed, the combustion blower and convection blower speed change as well.

Thermostat contacts are open (it is satisfied).

1. The stove's HEAT LEVEL and Fans will drop down to the LOW setting for 30 minutes.
2. If the thermostat contacts close within the 30 minutes, the HEAT LEVEL will return to the previous MANUAL setting.

OR

If the thermostat contacts remain open the stove automatically begins its shutdown routine.

- a. All lights turn off.
- b. Auger stops feeding.
- c. Combustion blower goes to full speed until exhaust sensor opens and blower stops.

The ON / OFF button can be presses at any time the the stove will immediately shut down. The stove will re-light when the thermostat contacts close again.

DHC 4100 SHUT DOWN - AUTO/OFF MODE, WITH THERMOSTAT OR WALL SWITCH:

Thermostat contacts are closed (it is calling for heat).

The stove will not shut off.

If you push ON/OFF button the circuit board will go through a start-up sequence (see DHC 4100 START-UP SEQUENCE (15 MINUTES) - ON/OFF MODE, WITH THERMOSTAT OR WALL SWITCH).

Thermostat contacts are open (it is satisfied).

1. Push ON/OFF button to turn stove off, turn the thermostat down, or off
2. The unit will run on low for three (3) minutes before it turns off.
3. All lights turn off.
3. Auger stops feeding.
4. Combustion blower goes to full speed until exhaust sensor opens and blower stops.

STOVE OPERATION - CIRCUIT BOARD

DHC 4110 START-UP SEQUENCE (15 MINUTES) - MANUAL MODE, FACTORY SETTING:

NOTE: No Thermostat or Wall Switch - All control of circuit board function is adjusted at the circuit board.

Note: Fuel Type can only be changed when the unit is cold. The thermostat mode can be changed during normal operation.

1. Push the ON/OFF button to start. The stove may take up to 30 seconds to establish firebox vacuum.
2. The Fuel Type Light will flash (the Auger Feed Rate is pre-programmed during start-up).
3. The Heat Level Indicator will show the Heat Level that the stove will run at after start-up.
4. The ignitor comes on.
5. The agitator will not operate for the first ten (10) minute after the ON button has been pressed. After the ten (10) minutes it will pulse at the same interval as the feed auger.
6. When the start-up sequence is complete the unit will ramp up to its heat level setting, this may take up to fifteen (15) minutes.
7. Once a fire has been established, the convection blower will turn on after ten (10) minutes.

DHC 4110 NORMAL OPERATION - MANUAL MODE, FACTORY SETTING:

Press the Heat Level buttons to change the desired Heat Level Output setting.

The speed of the convection blower is controlled by the setting of the heat level.

The Feed Trim button pressed in conjunction with the Heat Level adjustment buttons to adjust the Feed Trim. It can be increased by two (2) feed settings or it can be decreased by two (2) feed settings.

The M-55-FS has an automatic cleaning cycle; every thirty (30) minutes the agitator will turn continuously for one (1) minute to help clean out the burn pot liner.

DHC 4110 SHUT DOWN - MANUAL MODE, FACTORY SETTING:

1. Push ON/OFF button to turn stove off.
2. All the lights will turn off
3. The auger will stop feeding
4. The combustion blower goes to full speed until the exhaust temperature sensor opens, stopping all motors.

NOTE: On shut down the burn pot agitator will run continuously for five (5) minutes on premium mode, one (1) minute on regular mode, and five (5) minutes on multi-fuel mode.

DHC 4110 START-UP SEQUENCE (15 MINUTES) - HIGH/LOW MODE, WITH THERMOSTAT OR WALL SWITCH:

Thermostat contacts open (it is satisfied) or closed (it is calling for heat) at time of start-up.

Note: Fuel Type can only be changed when the unit is cold. The thermostat mode can be changed during normal operation.

1. Push the ON/OFF button to start. The stove may take up to 30 seconds to establish firebox vacuum.
2. The Fuel Type Light will flash (the Auger Feed Rate is pre-programmed during start-up).
3. The Heat Level Indicator will show the Heat Level that the stove will run at after start-up.
4. The ignitor comes on.
5. The agitator will not operate for the first ten (10) minute after the ON button has been pressed. After the ten (10) minutes it will pulse at the same interval as the feed auger.

STOVE OPERATION - CIRCUIT BOARD

6. When the start-up sequence is complete the unit will ramp up to its heat level setting, this may take up to fifteen (15) minutes.
7. Once a fire has been established, the convection blower will turn on after ten (10) minutes.

DHC 4110 NORMAL OPERATION - HIGH/LOW MODE, WITH THERMOSTAT OR WALL SWITCH:

The unit will cycle between set heat level and low as the thermostat calls for heat.

Thermostat contacts are closed (it is calling for heat).

When the thermostat calls for heat (contacts are closed) the stove settings are adjustable.

Press the Heat Level buttons to change the desired Heat Level Output setting.

The speed of the convection blower is controlled by the setting of the heat level.

The Feed Trim button pressed in conjunction with the Heat Level adjustment buttons to adjust the Feed Trim. It can be increased by two (2) feed settings or it can be decreased by two (2) feed settings.

The M-55-FS has an automatic cleaning cycle; every thirty (30) minutes the agitator will turn continuously for one (1) minute to help clean out the burn pot liner.

Thermostat contacts are open (it is satisfied).

The HEAT LEVEL and Fans will drop down to the LOW setting until the thermostat contacts close again. The stove will come back to the previous HEAT LEVEL setting once the thermostat contacts close.

DHC 4110 SHUT DOWN - HIGH/LOW MODE, WITH THERMOSTAT OR WALL SWITCH:

1. Push ON/OFF button to turn stove off.
2. All the lights will turn off
3. The auger will stop feeding
4. The combustion blower goes to full speed until the exhaust temperature sensor opens, stopping all motors.

NOTE: On shut down the burn pot agitator will run continuously for five (5) minutes on premium mode, one (1) minute on regular mode, and five (5) minutes on multi-fuel mode.

DHC 4110 START-UP SEQUENCE (15 MINUTES) - AUTO/OFF MODE, WITH THERMOSTAT OR WALL SWITCH:

Thermostat contacts closed (it is calling for heat) at time of start-up.

Note: Fuel Type can only be changed when the unit is cold. The thermostat mode can be changed during normal operation.

1. Push the ON/OFF button to start. The stove may take up to 30 seconds to establish firebox vacuum.
2. The Fuel Type Light will flash (the Auger Feed Rate is pre-programmed during start-up).
3. The Heat Level Indicator will show the Heat Level that the stove will run at after start-up.
4. The ignitor comes on.
5. The agitator will not operate for the first ten (10) minute after the ON button has been pressed. After the ten (10) minutes it will pulse at the same interval as the feed auger.
6. When the start-up sequence is complete the unit will ramp up to its heat level setting, this may take up to fifteen (15) minutes.
7. Once a fire has been established, the convection blower will turn on after ten (10) minutes.

Thermostat contacts are open (it is satisfied) when the ON/OFF button is pressed.

The circuit board will not turn on.

STOVE OPERATION - CIRCUIT BOARD

DHC 4110 NORMAL OPERATION - AUTO/OFF MODE, WITH THERMOSTAT OR WALL SWITCH:

Thermostat contacts are closed (it is calling for heat).

When the thermostat contacts close, the unit will light automatically. Once up to temperature, the stove settings are adjustable.

Press the Heat Level buttons to change the desired Heat Level Output setting.

The speed of the convection blower is controlled by the setting of the heat level.

The Feed Trim button pressed in conjunction with the Heat Level adjustment buttons to adjust the Feed Trim. It can be increased by two (2) feed settings or it can be decreased by two (2) feed settings.

The M-55-FS has an automatic cleaning cycle; every thirty (30) minutes the agitator will turn continuously for one (1) minute to help clean out the burn pot liner.

Please note: When the heat output is changed, the combustion blower and convection blower speed change as well.

Thermostat contacts are open (it is satisfied).

1. The stove's HEAT LEVEL and Fans will drop down to the LOW setting for 30 minutes.
2. If the thermostat contacts close within the 30 minutes, the HEAT LEVEL will return to the previous MANUAL setting.
OR
If the thermostat contacts remain open, the stove automatically begins its shutdown routine.

The stove will re-light when the thermostat contacts close again.

DHC 4110 SHUT DOWN - AUTO/OFF MODE, WITH THERMOSTAT OR WALL SWITCH:

Thermostat contacts are closed (it is calling for heat).

The stove will not shut off.

If you push ON/OFF button the circuit board will go through a start-up sequence (see DHC 4100 START-UP SEQUENCE (15 MINUTES) - ON/OFF MODE, WITH THERMOSTAT OR WALL SWITCH).

Thermostat contacts are open (it is satisfied).

1. Push ON/OFF button to turn stove off, turn the thermostat down or Timer off
2. The unit will run on low for three (3) minutes before it turns off.
3. All lights turn off.
3. Auger stops feeding.
4. Combustion blower goes to full speed until exhaust sensor opens and blower stops.

NOTE: On shut down the burn pot agitator will run continuously for five (5) minutes on premium mode, one (1) minute on regular mode, and five (5) minutes on multi-fuel mode.

DHC 4100 PROGRAM OPERATION DESCRIPTIONS:

(Not for Omega, Empress/Milan FPI, or M55)

Program 1: Same as 3000 circuit board parameter – for all pellet stoves with the exception of units listed with programs #2, 3, 4. – One flash

Program 2: Convection fan button disabled – Empress FS – two flashes.

Program 3: 60,000 Btu feed rate – Maxx – three flashes (Note: To achieve 70,000 Btu, for Maxx only, you need to trim up the feed rate on program 3.)

Program 4: 50,000 Btu feed rate – Maxx – four flashes

STOVE OPERATION - CIRCUIT BOARD

DHC 4110 PROGRAM OPERATION DESCRIPTIONS:

- Safety switches
- Open proof of fire #3 flash code
 - Open vacuum stops auger, igniter and stirrer.
 - Open high limit #4 flash code

Program #1 (Premium Pellets)

Start-Up

- Pre-feed for 2 minutes
- Hold stirrer off for 10 minutes
- At 10 minutes check for proof of fire
- Run startup till 15 minutes
- If proof of fire not at 15 minutes run shut down combustion fan for 7 minutes.

Run Mode

- Stirrer on for 1 minute off for 30 minutes

Shut Down

- Stir for 5 minutes
- Run combustion fan till proof of fire opens

Program #2 (Regular Pellets)

Start up

- Pre-feed for 2 minutes
- Hold stirrer off for 10 minutes
- At 10 minutes check for proof of fire
- Run startup till 15 minutes
- If proof of fire not at 15 minutes run shut down combustion fan for 7 minutes.

Run Mode

- Stirrer pulses same as the auger.

Shut Down

- Stir for 1 minute
- Run combustion fan till proof of fire opens

Program #3 (Multi-Fuel)

Start up

- Pre-feed for 2 minutes
- Hold stirrer off for 5 minutes
- Run startup till 15 minutes
- If proof of fire not at 15 minutes run shut down combustion fan for 7 minutes.

Run Mode

- Stirrer pulses same as the auger.
- Ramp feed up 1 minute each setting till at set feed rate.
- Every 30 minutes drop feed to low and run stirrer continues for 1min
- After 30 minutes cleaning cycle ramp feed rate back to set feed rate.

Shut Down

- Stir for 5 minutes
- Run combustion fan till proof of fire opens

THE HOW TO'S FOR TROUBLESHOOTING

SUGGESTED TOOLS LIST:

- Ratchet and Sockets: 1/4" to 5/8"
- Screwdrivers: T-20 Torx, Robertson, Straight Blade
- Penetrating Lubricant (WD-40)
- High Temperature Silicone (RTV) 500°F
- Magnehelic Pressure Gauge
- Needle Nose Pliers, Wire Cutters, Strippers, and Crimpers

- Open ended Wrenches: 1/4" to 1/2"
- Cordless Drill / Screwdriver
- 1/4" Insulated connectors
- Electrical Tape
- Multimeter
- Jumper wires



Figure 18: Assorted Suggested Tools.



Figure 19: Digital Multimeter.

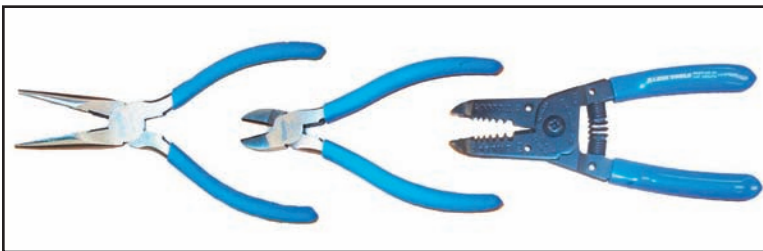

Figure 21: Needle Nose Pliers, Wire Cutters, Strippers, and Crimpers.

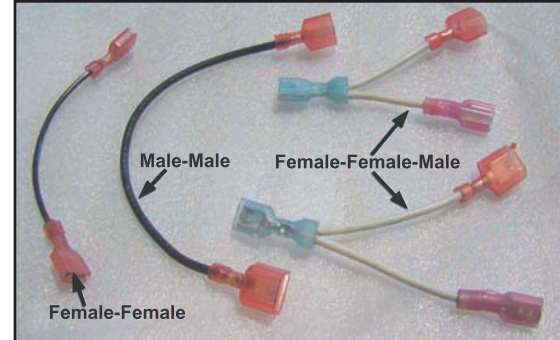

Figure 20: Recommended Jumper Wires.

TROUBLESHOOTING WARNINGS:

DO NOT:

- Hold the ON / OFF BUTTON down for circuit board model or hold the start-up switch down for timer control. This is a momentary contact switch and can be damaged if held down too long.
- Service the stove with wet hands. The stove is an electrical appliance, which may pose a shock hazard if handled improperly. Only qualified technicians should deal with possible internal electrical failures.
- Remove any screws in the firebox without first lubricating them with penetrating oil.

NOTE: To reset Circuit Board after a trouble code - push the ON/OFF button once.

Caution: The use of power tools to remove screws may strip the holes.



THE HOW TO'S FOR TROUBLESHOOTING

HOW TO BY-PASS THE DIAL-A-FIRE:

This is for Timer Control models.

The dial-a-fire is found behind the right cabinet side.

Use a female-female connector to by-pass the dial-a-fire as shown in Figure 22.

Used in TROUBLESHOOTING section "THE AUGER TIMER WILL NOT FUNCTION NORMALLY - TIMER CONTROL ONLY".

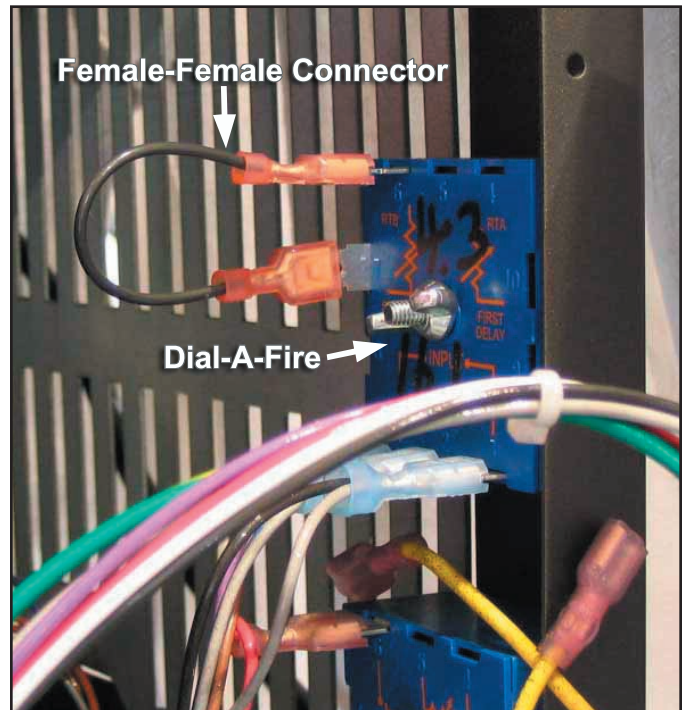

Figure 22: By-Passing The Dial-A-Fire.

HOW TO BY-PASS THE START-UP SWITCH:

This is for Timer Control models.

The start-up switch is found on the inside of the right cabinet side.

Bypass the start-up switch by inserting a male-male connector between the red and white wires that attach to the switch as shown in Figure 23.

Used in TROUBLESHOOTING section "THE STOVE WILL NOT START".

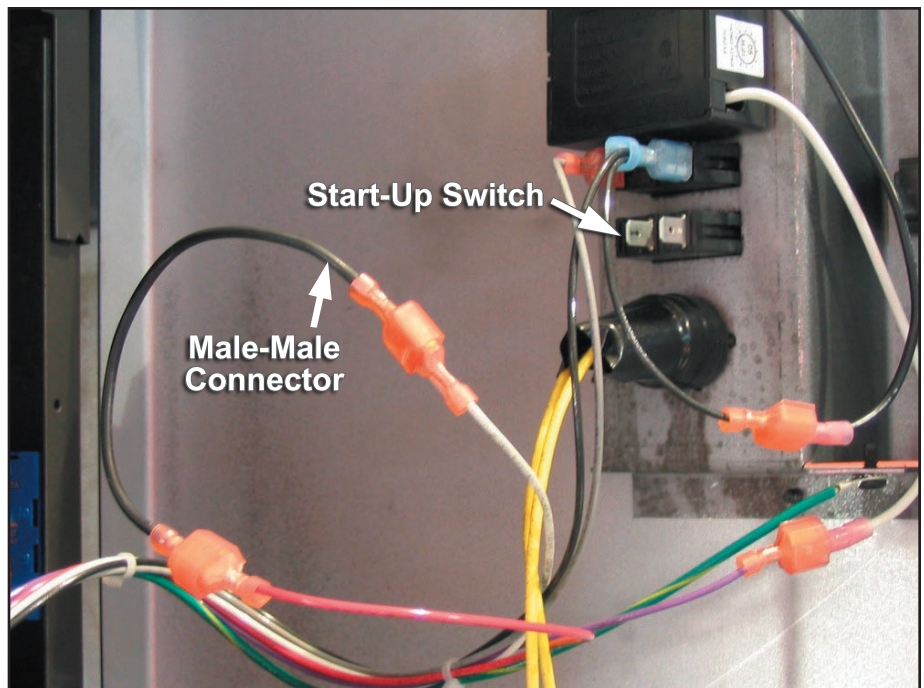

Figure 23: By-Passing The Start-Up Switch.

THE HOW TO'S FOR TROUBLESHOOTING

How To BY-PASS THE FAN CONTROLLER:

This is for Timer Control models.

The fan controller is found on the inside of the right cabinet side.

Use a female-female connector to by-pass the fan controller as shown in Figure 24.

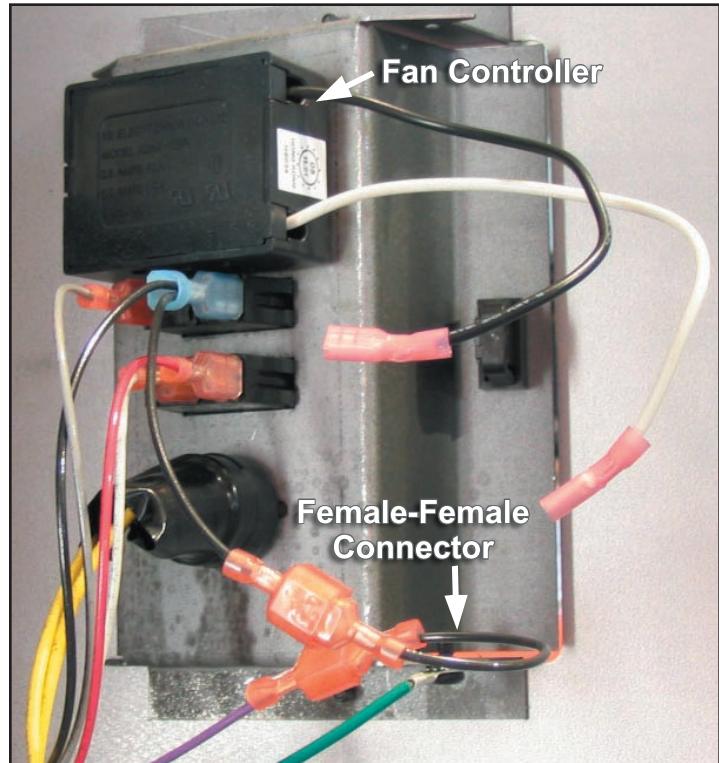

Figure 24: By-Passing The Fan Controller.

How To BY-PASS THE 200°F MANUAL RESET:

The 200°F manual reset is found behind the right cabinet side.

Use a female-female connector to by-pass the 200°F manual reset as shown in Figure 25.

Used in TROUBLESHOOTING sections "THE AUGER MOTOR WILL NOT FUNCTION NORMALLY" & "THE AUGER LIGHT FLASHES BUT THE AUGER DOES NOT TURN AT ALL".

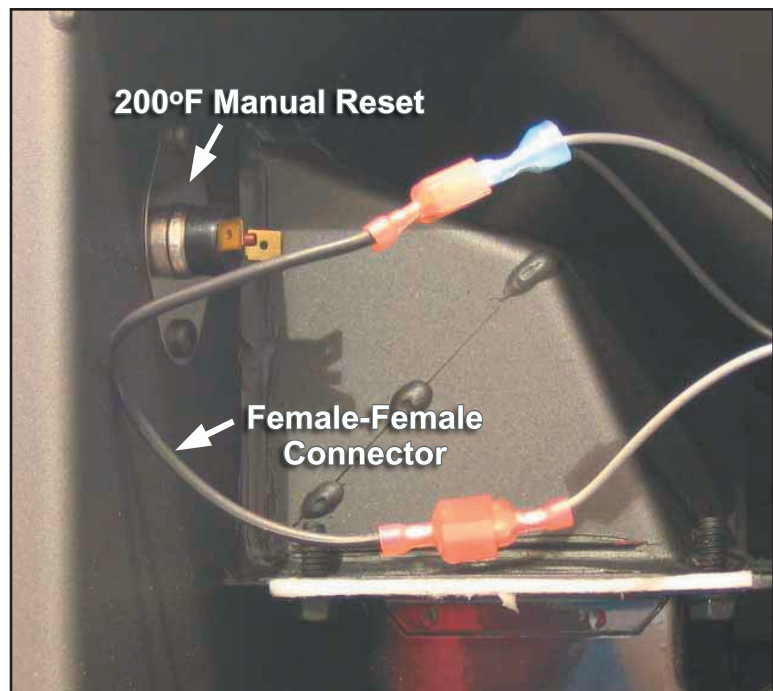

Figure 25: By-Passing The 200°F Manual Reset.

THE HOW TO'S FOR TROUBLESHOOTING

HOW TO LUBRICATE THE CONVECTION BLOWER:

The convection blower is found behind the right cabinet side.

The lubrication holes are shown in Figure 26.

ONLY use 1 or 2 drops of light oil SAE 20 or 3 in 1, an excess of oil does more harm than good.

IMPORTANT: This is only for the EF2, EF3, EF4, Empress FPI, Milan FPI, Meridian FPI, and Meridian FS.

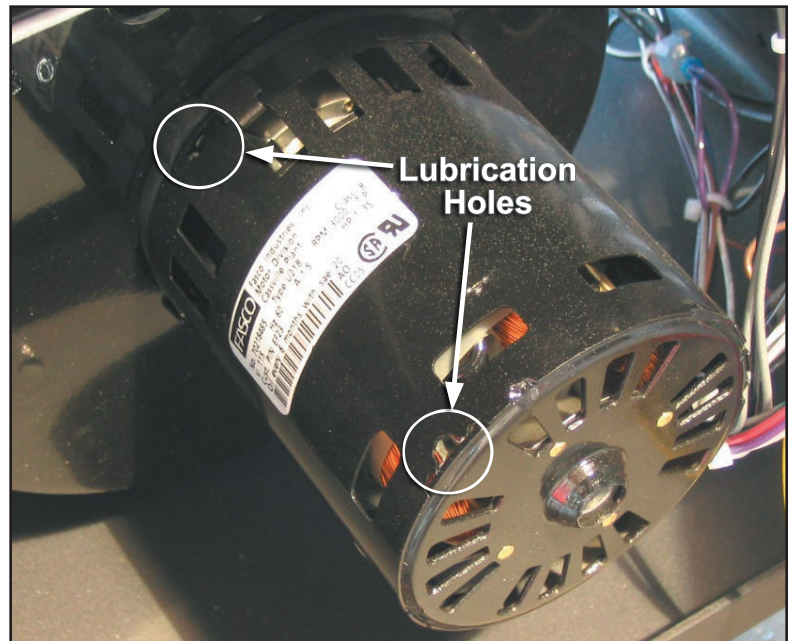

Figure 26: Lubrication Holes On The Convection Blower.

HOW TO REMOVE THE CONVECTION BLOWER:

The convection blower is found behind the right cabinet side.

Remove the two (2) bolts shown in Figure 27 using an 8mm socket or wrench.

Used in TROUBLESHOOTING sections " THE 200°F (93°C) HIGH LIMIT TEMPERATURE SENSOR HAS TRIPPED", "THE CONVECTION BLOWER WILL NOT FUNCTION NORMALLY" & "THE AUGER LIGHT FLASHES BUT THE AUGER DOES NOT TURN AT ALL".



Figure 27: Removing The Convection Blower.

THE HOW TO'S FOR TROUBLESHOOTING

HOW TO BY-PASS THE 160°F FAN SENSOR:

The 160°F fan sensor is found behind the left cabinet side.

Use a male-male connector to by-pass the 160°F fan sensor as shown in Figure 28.

Used in TROUBLESHOOTING sections "THE 200°F (93°C) HIGH LIMIT TEMPERATURE SENSOR HAS TRIPPED" & "THE AUGER LIGHT FLASHES BUT THE AUGER DOES NOT TURN AT ALL".

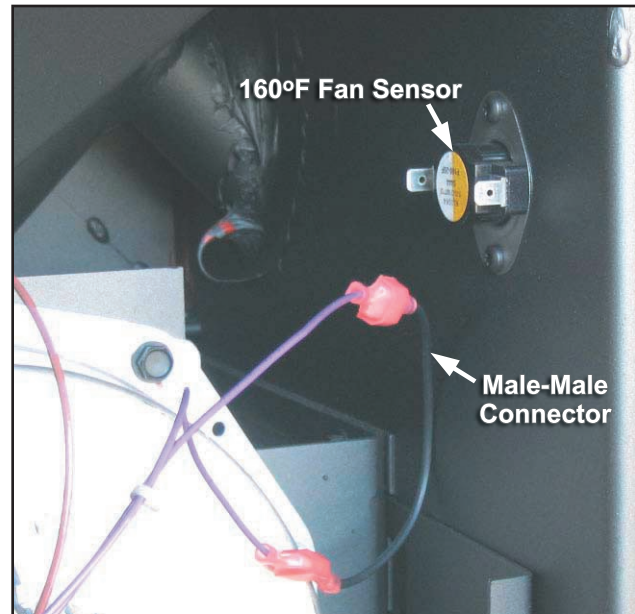

Figure 28: By-Passing The 160°F Fan Sensor.

HOW TO BY-PASS THE VACUUM SWITCH:

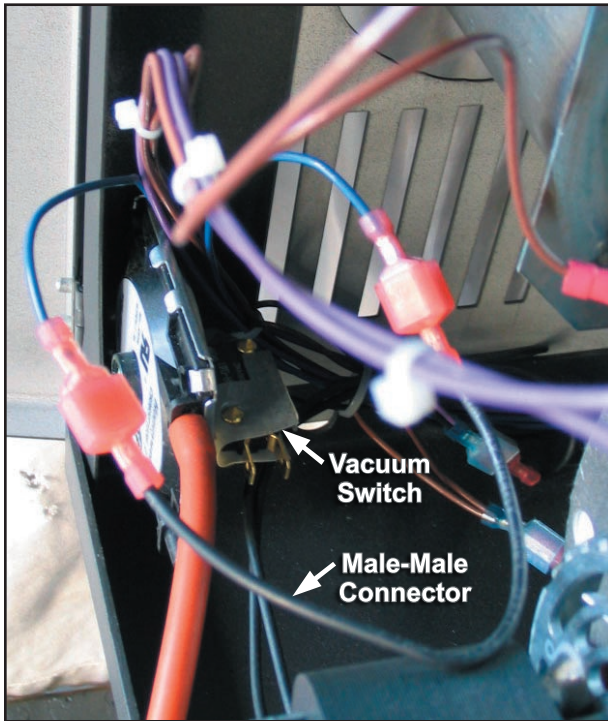

Figure 29: By-Passing The Vacuum Switch (Pre September 2008).

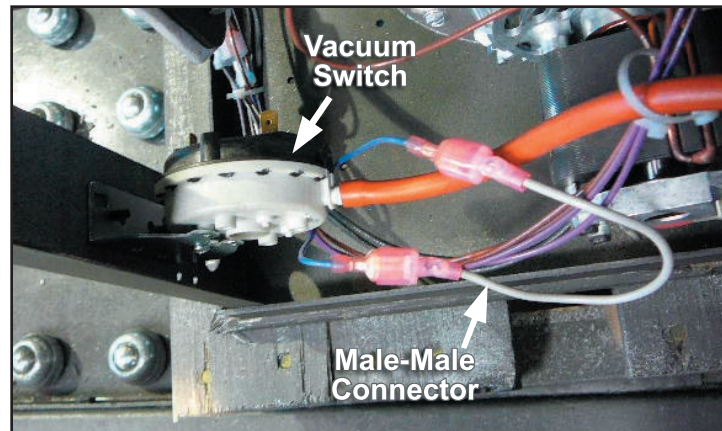

Figure 30: By-Passing The Vacuum Switch (Post September 2008).

The vacuum switch is found behind the left cabinet side.

Use a male-male connector to by-pass the vacuum switch as shown in Figure 29 & 30.

Used in TROUBLESHOOTING sections "THE STOVE WILL NOT OPERATE WHEN HOT".

Used in TROUBLESHOOTING sections "THE STOVE WILL NOT OPERATE WHEN HOT", "THE AUGER MOTOR WILL NOT FUNCTION NORMALLY", "LIGHT #2 ON HEAT OUTPUT BAR FLASHING - CIRCUIT BOARD ONLY", & "LIGHT #3 ON HEAT OUTPUT BAR FLASHING - CIRCUIT BOARD ONLY".

THE HOW TO'S FOR TROUBLESHOOTING

HOW TO BY-PASS EXHAUST TEMPERATURE SENSOR/SWITCH:

The exhaust temperature sensor/switch is found behind the left cabinet side.

Place both connectors on same side of the exhaust temperature sensor/switch or jumper the wires together as shown in Figure 31.

Used in TROUBLESHOOTING section "THE STOVE WILL NOT OPERATE WHEN HOT".

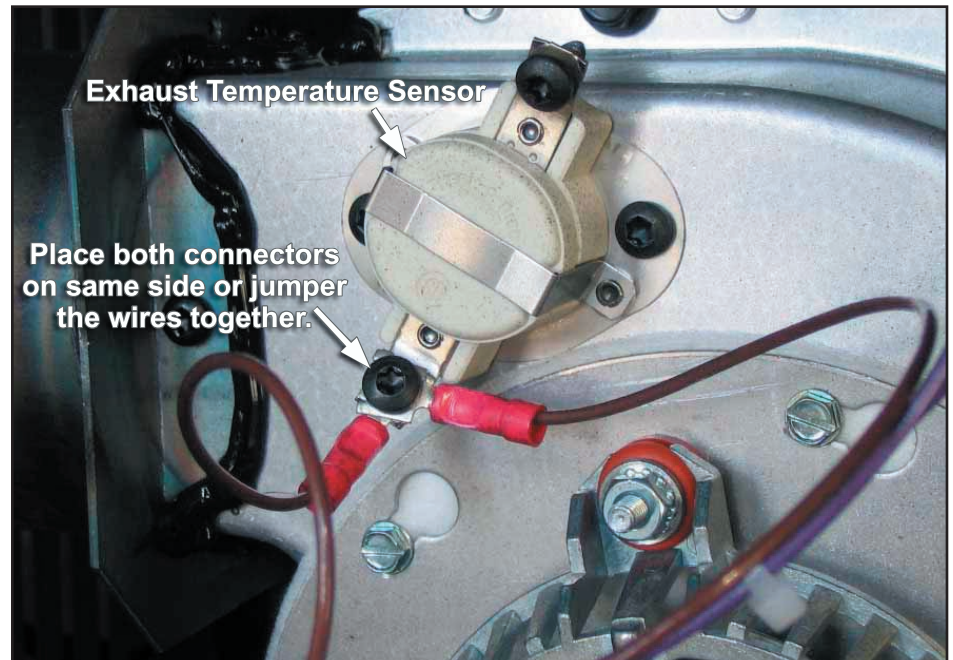

Figure 31: By-Passing The Exhaust Temperature Sensor/ Switch (EF 3 Shown).

HOW TO REMOVE THE EXHAUST BLOWER MOTOR:

The exhaust blower motor is found behind the left cabinet side.

1. Loosen, but do not remove, the six (6) screws using a 1/4" socket (refer to Figure 32).
2. Turn the motor counter-clockwise (refer to Figure 33).
3. Remove the exhaust blower motor.

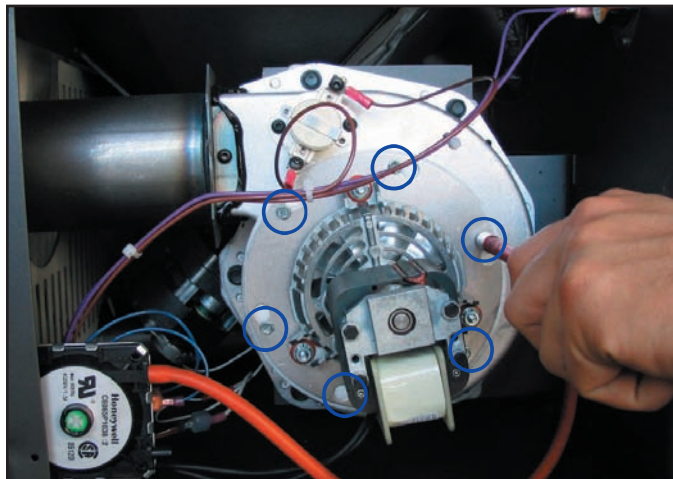

Figure 32: Loosening The Screws On The Exhaust Blower Motor.

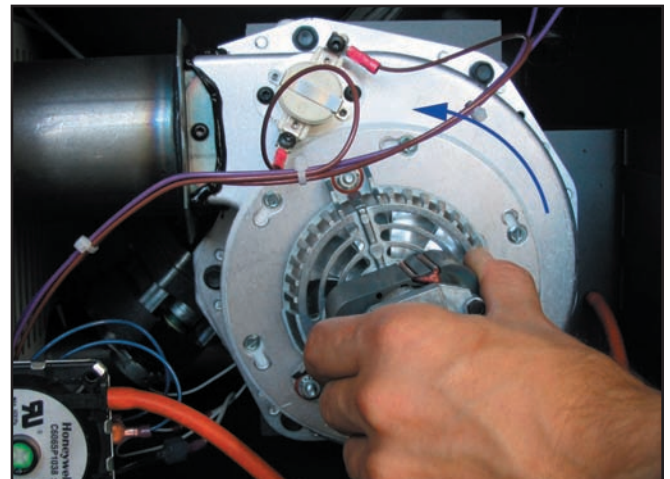

Figure 33: Removing The Exhaust Blower Motor.

Used in TROUBLESHOOTING section "THE COMBUSTION (EXHAUST) MOTOR WILL NOT FUNCTION NORMALLY".

THE HOW TO'S FOR TROUBLESHOOTING

HOW TO BY-PASS THE 120°F IGNITOR TEMPERATURE SENSOR/SWITCH:

The 120°F ignitor temperature sensor/switch is found on the air channel behind the back panel.

Use a male-male connector to bypass the 120°F ignitor temperature sensor/switch as shown in Figure 34.

Caution: Use care when removing the wires, as the sensor can be damaged.

Used in TROUBLESHOOTING section "THE IGNITOR WILL NOT WORK".

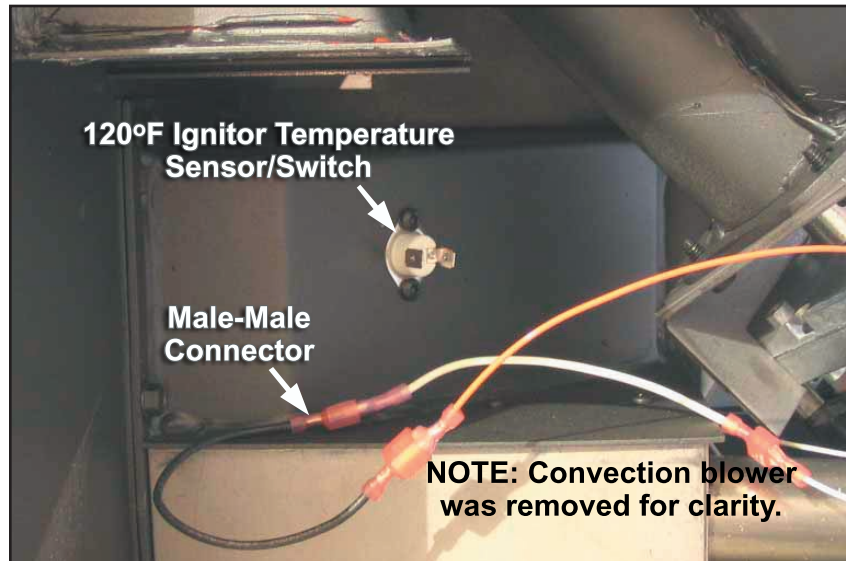

Figure 34: By-Passing The 120°F Ignitor Temperature Sensor/Switch.

HOW TO MEASURE RESISTANCE ACROSS THE DIAL-A-FIRE:

This is for Timer Control models.

The dial-a-fire is found behind the right cabinet side.

Potentiometer Readings:

The potentiometer should have a range of approximately 68K Ω to 850 K Ω (\pm 10%).

Full counter-clockwise (switched off) = open circuit, overload or infinite resistance

Low fire 800 K Ω to 900 K Ω

High fire 68 K Ω to 82 K Ω (EF4 Timer Control 36.5 K Ω)

You should see a smooth increase/decrease, values shown in Figure 35 & 36 are: 68.5 – 806 K Ω .

Used in TROUBLESHOOTING section "THE AUGER TIMER WILL NOT FUNCTION NORMALLY - TIMER CONTROL ONLY" & "THE AUGER TIMER WILL NOT FUNCTION NORMALLY - TIMER CONTROL ONLY".

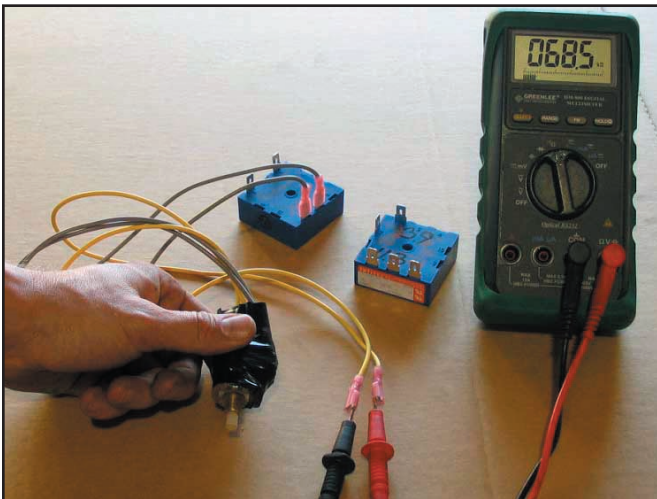

Figure 35: Measuring The Resistance Across The Dial-A-Fire - Low.

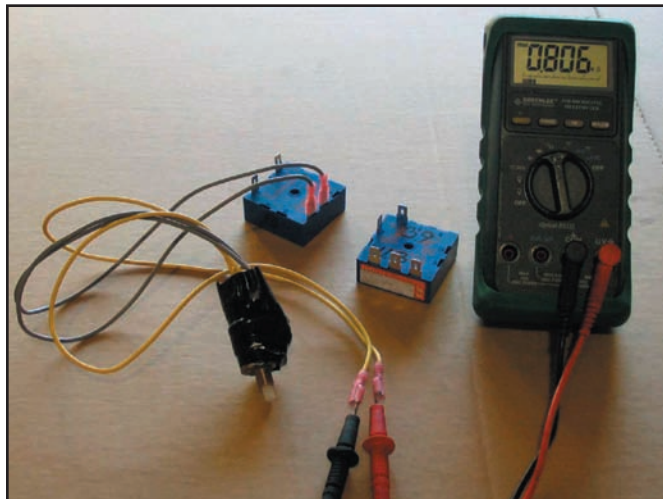

Figure 36: Measuring The Resistance Across The Dial-A-Fire - High.

THE HOW TO'S FOR TROUBLESHOOTING

HOW TO MEASURE THE EXHAUST BLOWER VOLTAGE:

The exhaust blower is found behind the left cabinet side.

Check the exhaust blower voltage across the blower wires. Set the meter to AC volts and place one probe to each wire of the fan. Normally it is equal to or greater than 114V on #5 setting and equal to or greater than 82V on #1 setting (refer to Figure 37).

Used in TROUBLESHOOTING sections "THE STOVE WILL NOT OPERATE WHEN HOT", "THE AUGER MOTOR WILL NOT FUNCTION NORMALLY", "LIGHT #2 ON HEAT OUTPUT BAR FLASHING - CIRCUIT BOARD ONLY", & "LIGHT #3 ON HEAT OUTPUT BAR FLASHING - CIRCUIT BOARD ONLY".

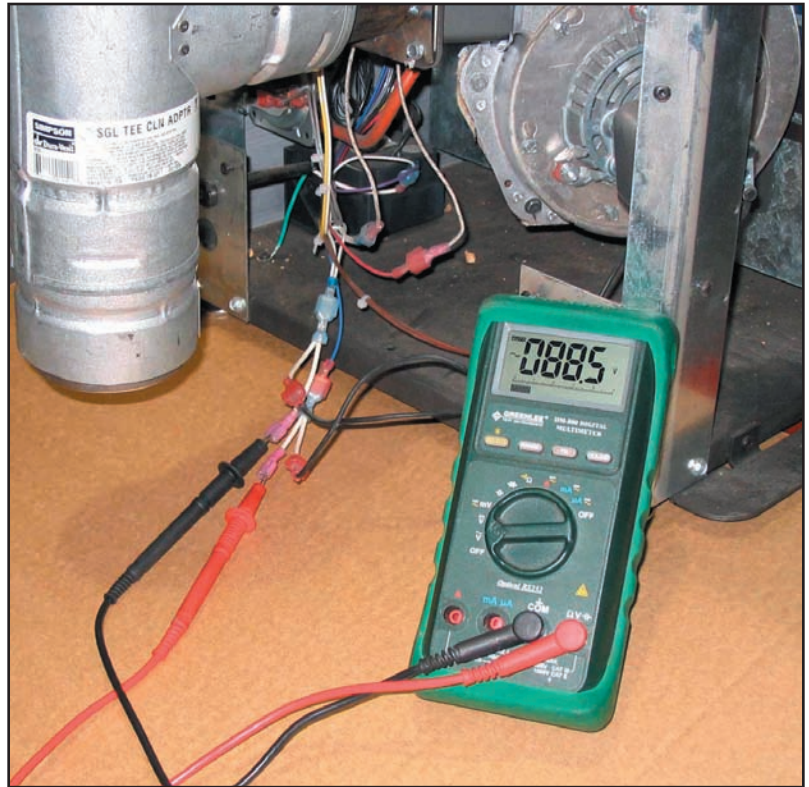

Figure 37: Measuring The Exhaust Blower Voltage.

HOW TO APPLY DIRECT POWER TO THE AUGER MOTOR:

Apply 115V AC directly to the auger blower with a test cord, by removing the two leads and plugging the motor in directly to a wall outlet, as shown in Figure 38.

Used in TROUBLESHOOTING sections "THE STOVE WILL NOT OPERATE WHEN HOT", "THE AUGER MOTOR WILL NOT FUNCTION NORMALLY".

Note: Use this method when applying direct power to the Convection and Exhaust blowers.

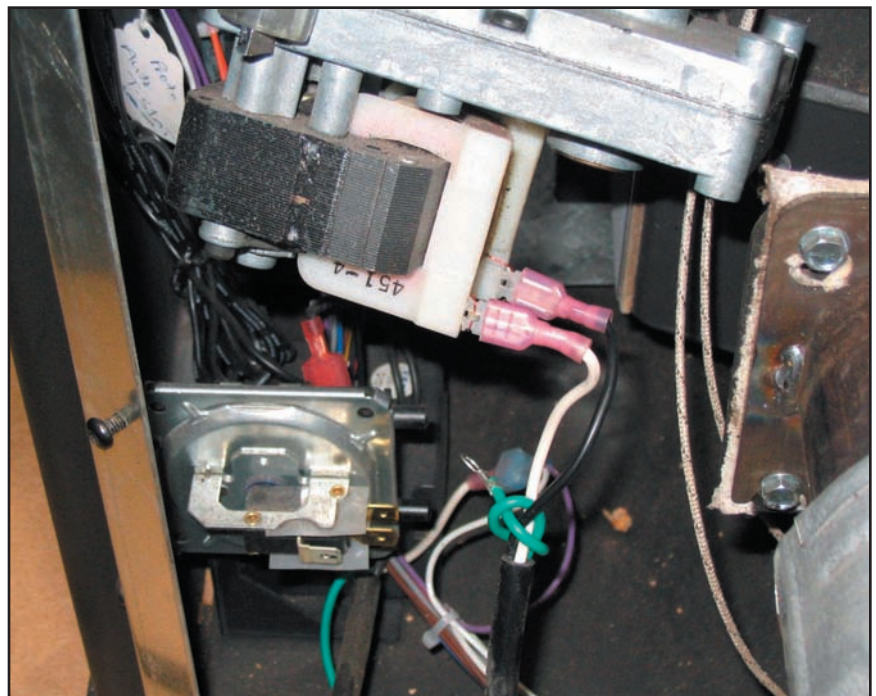

Figure 38: Applying Direct Power To The Auger Motor.

THE HOW TO'S FOR TROUBLESHOOTING

HOW TO MEASURE THE VACUUM LEVEL PRODUCED BY THE EXHAUST BLOWER:

The exhaust blower motor and vacuum switch is found behind the left cabinet side.

To measure the exhaust vacuum level, connect the sensor end of the vacuum tube to a magnehelic gauge as shown in Figure 39.

Refer to 'TABLE 1: STOVE SPECIFICATIONS FOR AMPERAGE, WATTAGES, AND MAGNEHELIC READINGS' IN STOVE SPECIFICATIONS for the proper readings needed for each model.

Note: Checking the vacuum reading on the exhaust manifold will give a higher reading than when taken from the firebox where we normally use the magnehelic to set damper airflow.

Used in TROUBLESHOOTING sections "THE STOVE WILL NOT OPERATE WHEN HOT", "THE AUGER MOTOR WILL NOT FUNCTION NORMALLY", "LIGHT #2 ON HEAT OUTPUT BAR FLASHING - CIRCUIT BOARD ONLY", & "LIGHT #3 ON HEAT OUTPUT BAR FLASHING - CIRCUIT BOARD ONLY".

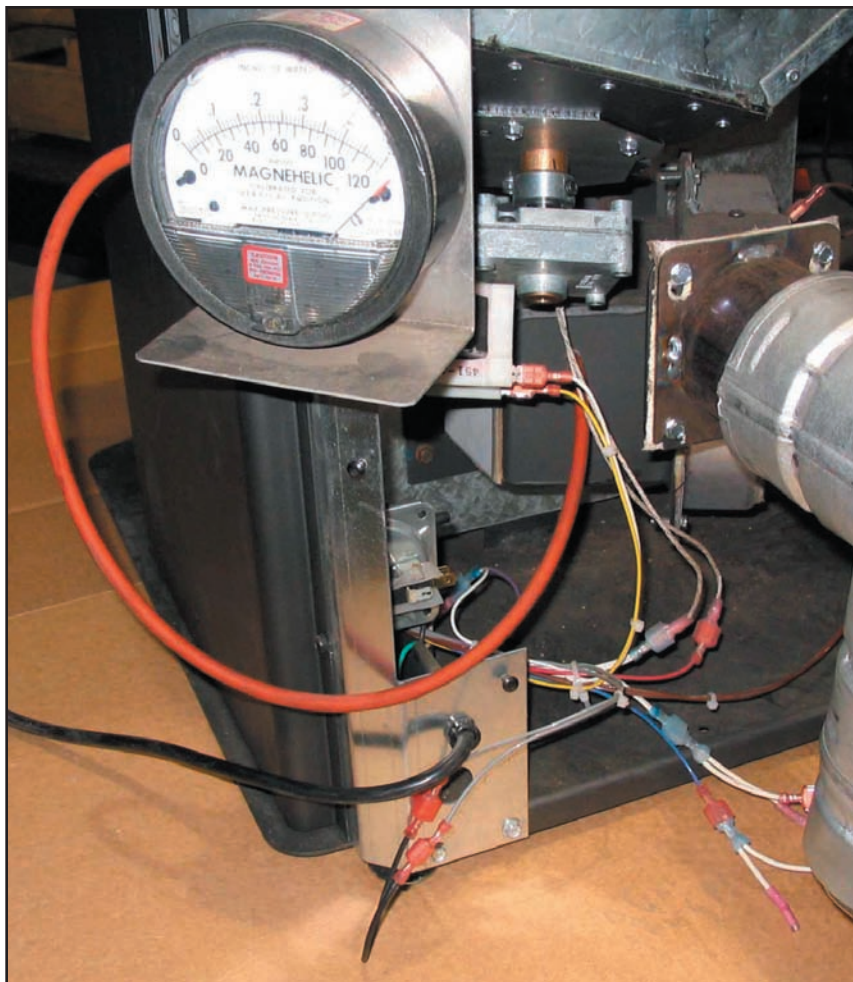

Figure 39: Measuring The Vacuum Level Produced By The Exhaust Blower.

HOW TO CHANGE PROGRAM ON DHC 4100:

Unplug unit and disconnect the high limit wire. Ensure unit is cold or disconnect exhaust temp wire and the circuit board switch is in the manual position. Plug the unit back in. Press the room air, feed trim, and combustion trim buttons all at the same time. All five (5) heat level lights will flash one to four (1-4) times depending on what program it is set to. Repeat until you have the desired program (see below – the board will hold this program as the default program. Unplug unit and reconnect sensors, plug the unit back in, and it is ready to use. Refer to "DHC 4100 PROGRAM OPERATION DESCRIPTIONS"

HOW TO START UP CYCLE BYPASS ON DHC 4100:

To bypass the fifteen (15) minute start up in all modes the exhaust temperature sensor must be closed/ bypassed. Press both the heat level up and down buttons and the room air button at the same time. You will now have control of the circuit board.

TROUBLESHOOTING

THE STOVE WILL NOT START:

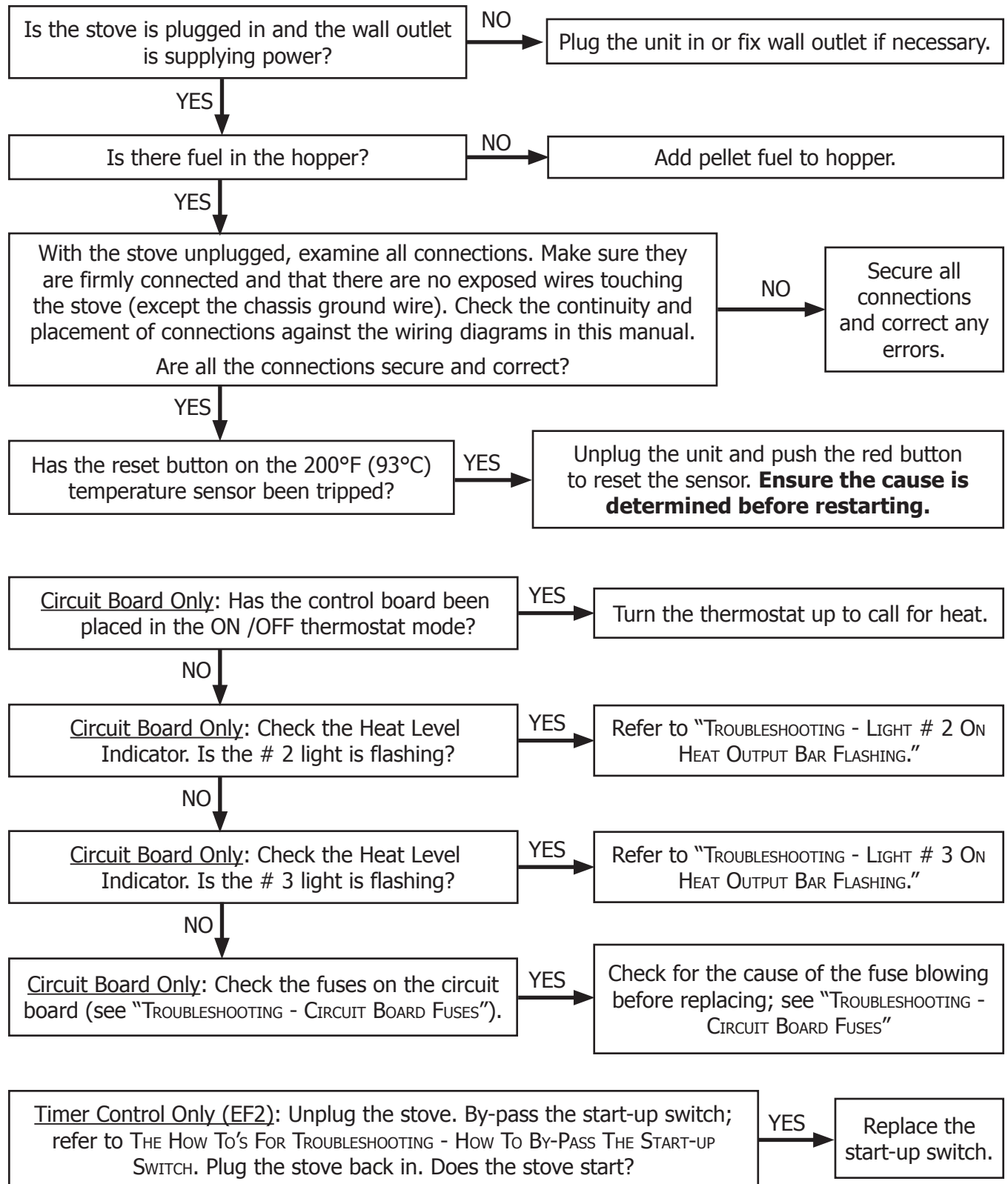

TROUBLESHOOTING

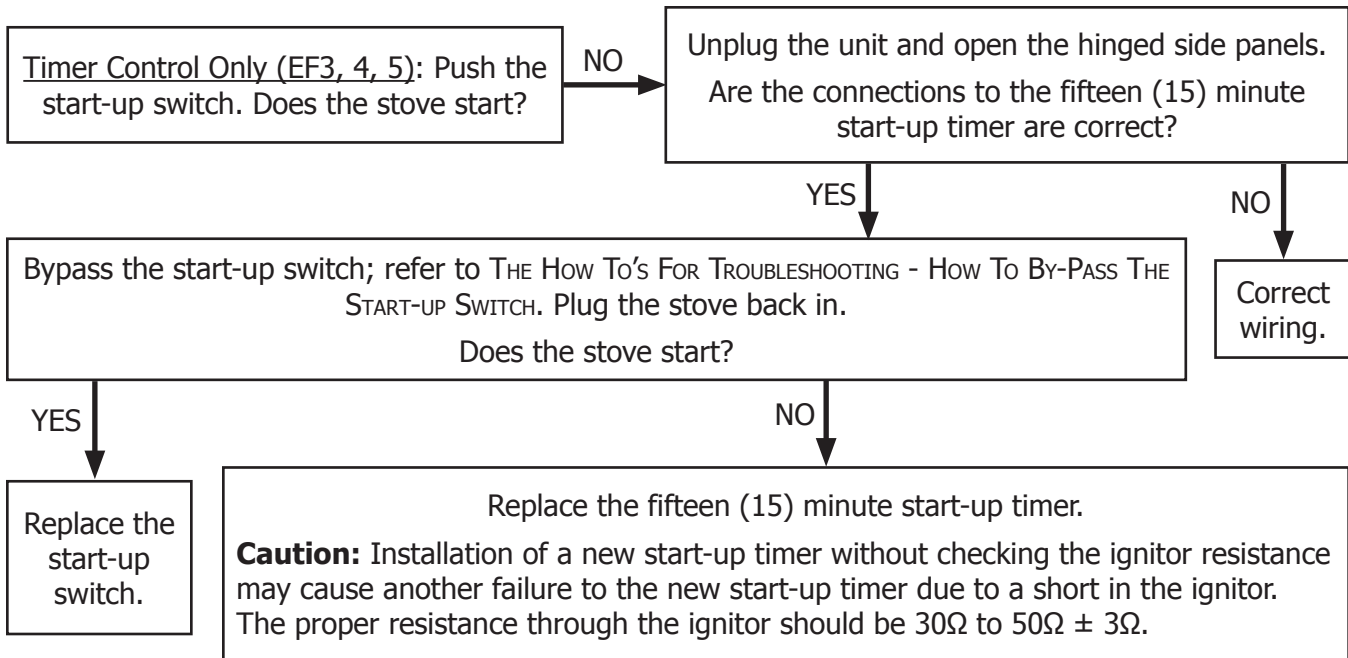

THE STOVE WILL NOT OPERATE WHEN HOT:

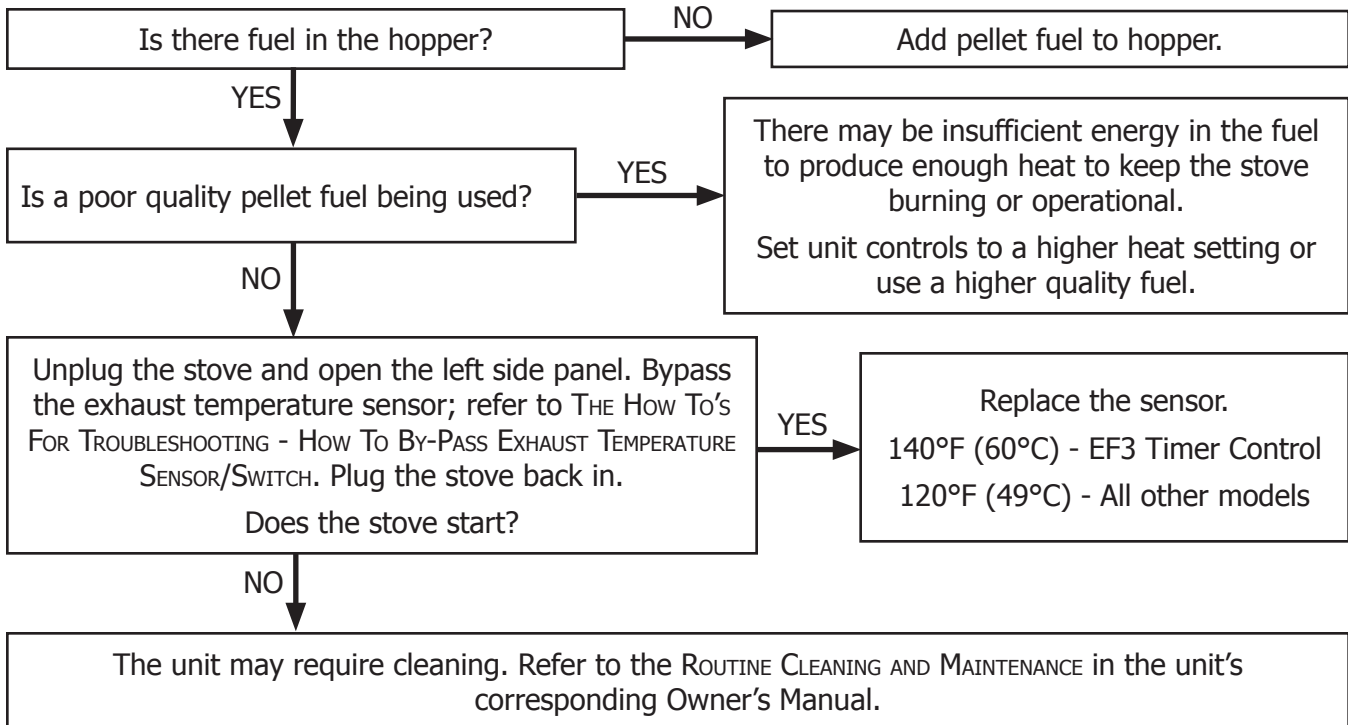

TROUBLESHOOTING

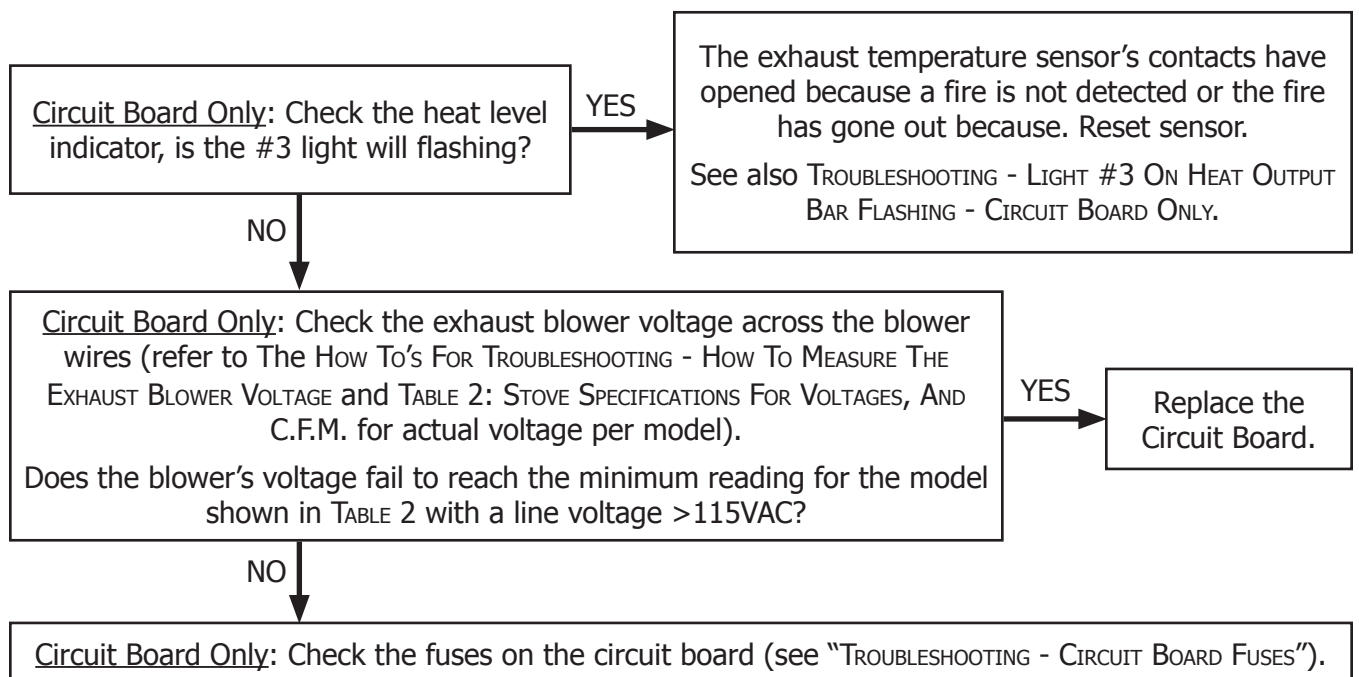
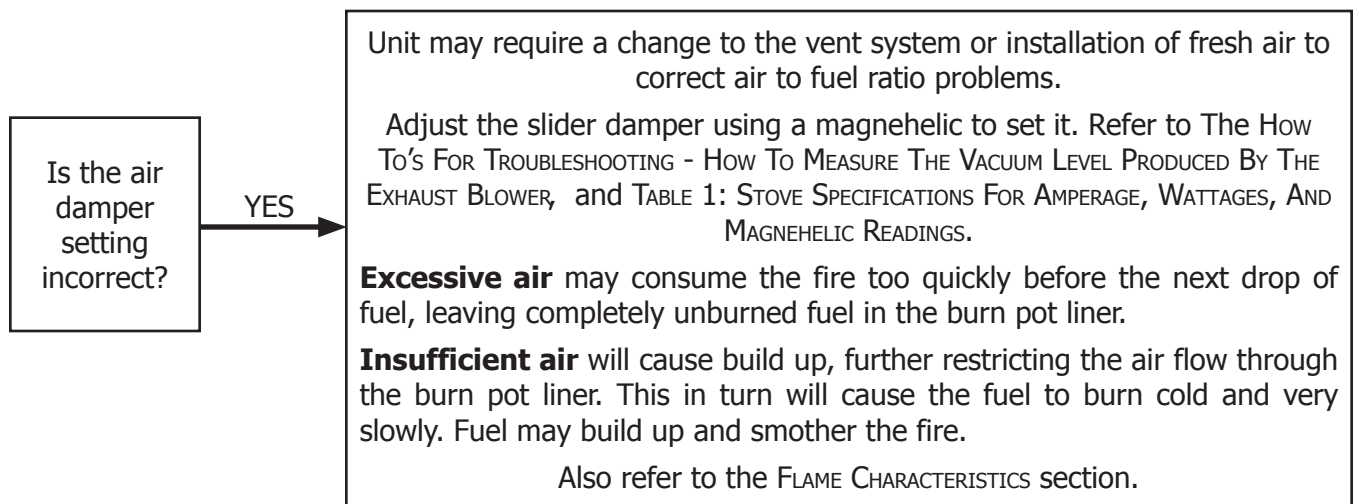
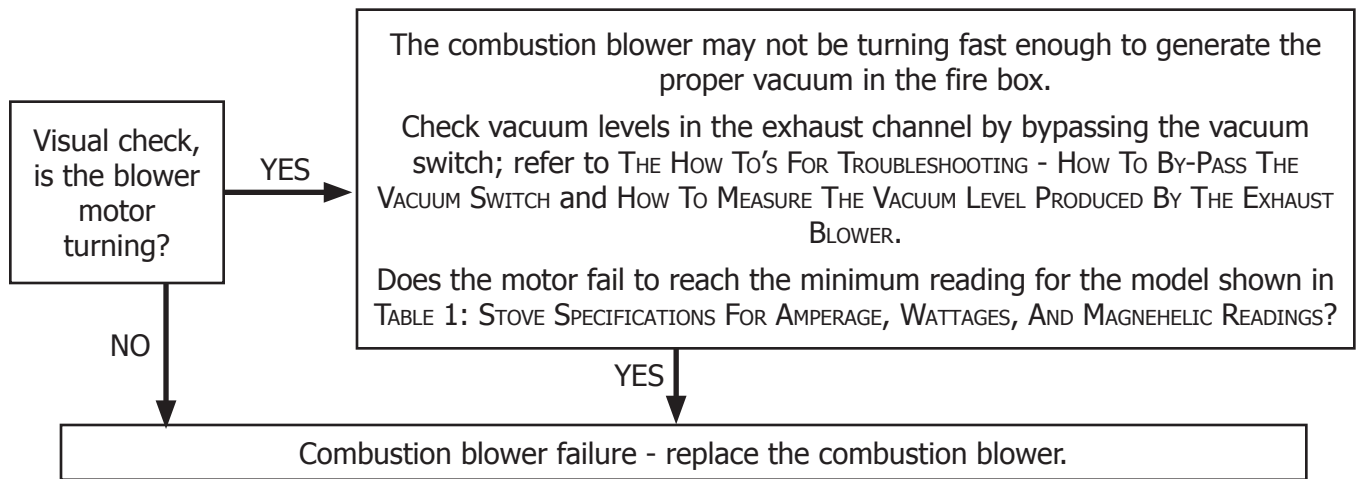

TROUBLESHOOTING

Timer Control Only (EF2): While HOT, unplug the stove. By pass the auto side of the switch with a jumper wire. Plug the stove back in.
Does the stove start automatically?

YES

Replace the start-up switch.

THE 200°F (93°C) HIGH LIMIT TEMPERATURE SENSOR HAS TRIPPED:

If this sensor has been tripped find try to determine the reasons for the over heating **before pushing red button in.**

Reset the sensor and determine the cause. Bypass the 160°F (71°C) sensor. Refer to The How To's FOR TROUBLESHOOTING - HOW TO BY-PASS THE 200°F MANUAL RESET.
Does the convection blower come on high?

YES

NO

Replace the 160°F (71°C) temperature sensor (refer to The How To's FOR TROUBLESHOOTING - HOW TO BY-PASS THE 160°F FAN SENSOR).

Replace the convection blower (refer to The How To's FOR TROUBLESHOOTING - HOW TO REMOVE THE CONVECTION BLOWER).

THE CONVECTION BLOWER WILL NOT FUNCTION NORMALLY:

Open the left side access panel; check all connections (especially the controller, switch, and convection blower) against the wiring diagram.
Are all the connections correct?

NO

Correct the errors.

Clean all grill openings at the back and below unit.

If the convection blower will not run, apply 115V AC directly to the convection motor with a test cord by removing the two leads and plugging the motor in directly.
Does the convection blower run?

NO

YES

The convection blower has failed. Replace the blower (refer to The How To's FOR TROUBLESHOOTING - HOW TO REMOVE THE CONVECTION BLOWER).

Replace the convection fan controller / circuit board.

TROUBLESHOOTING

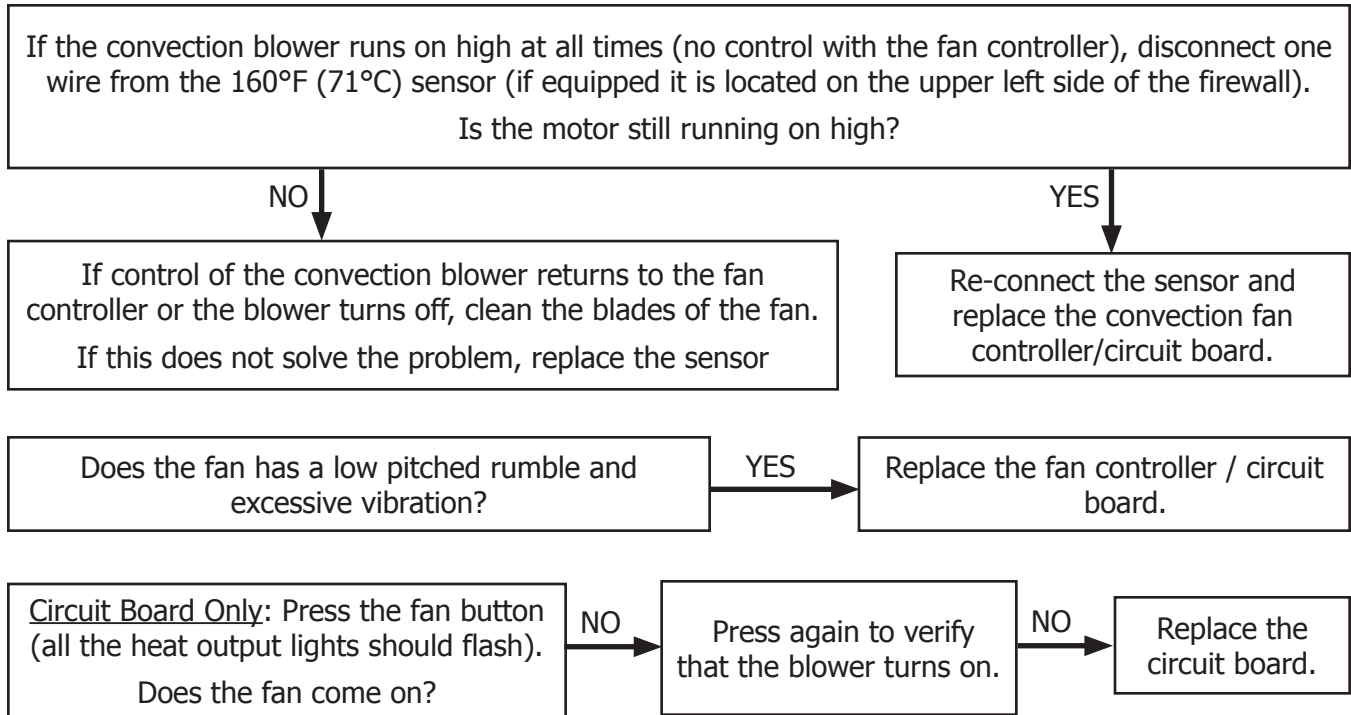

THE COMBUSTION (EXHAUST) MOTOR WILL NOT FUNCTION NORMALLY:

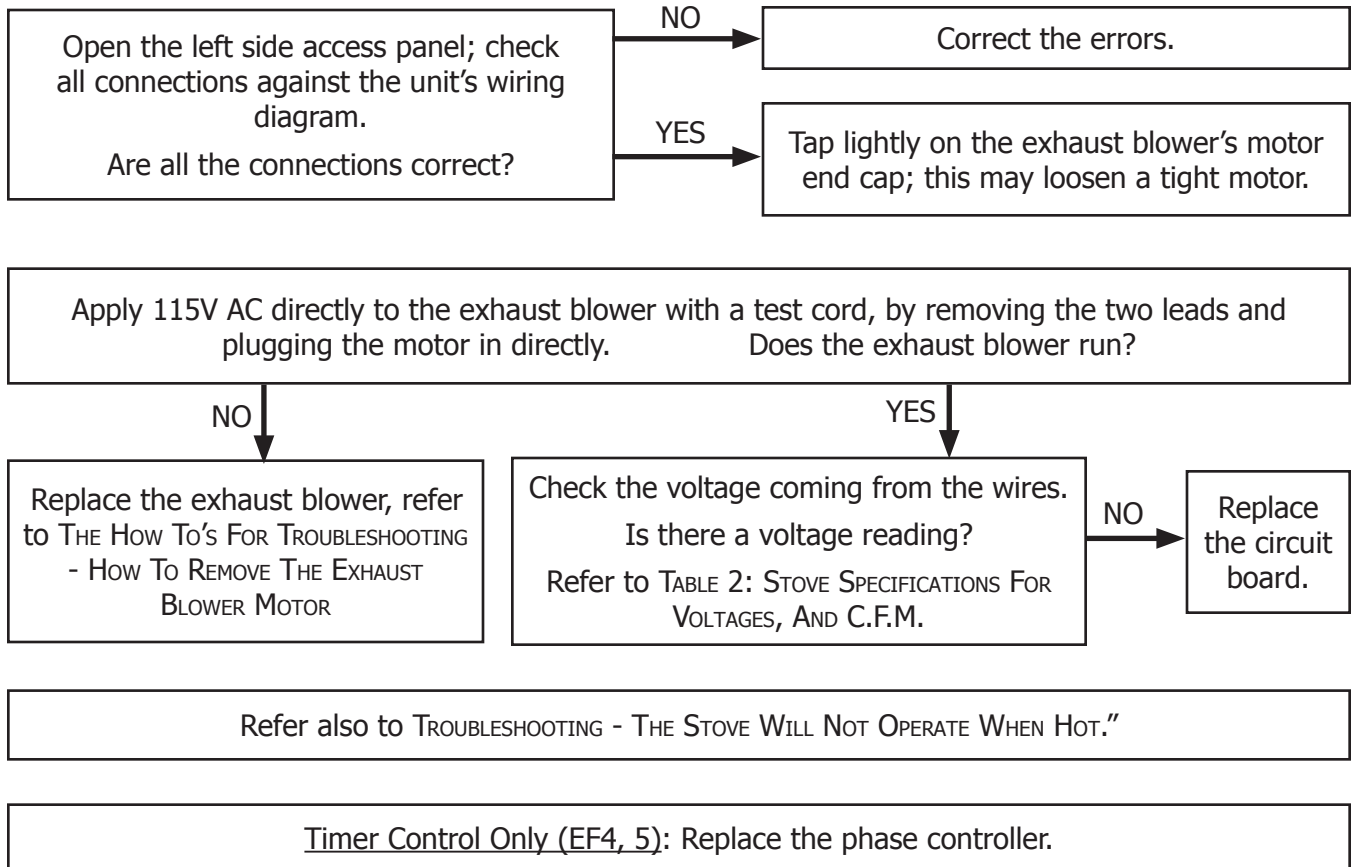

TROUBLESHOOTING

THE AUGER MOTOR WILL NOT FUNCTION NORMALLY:

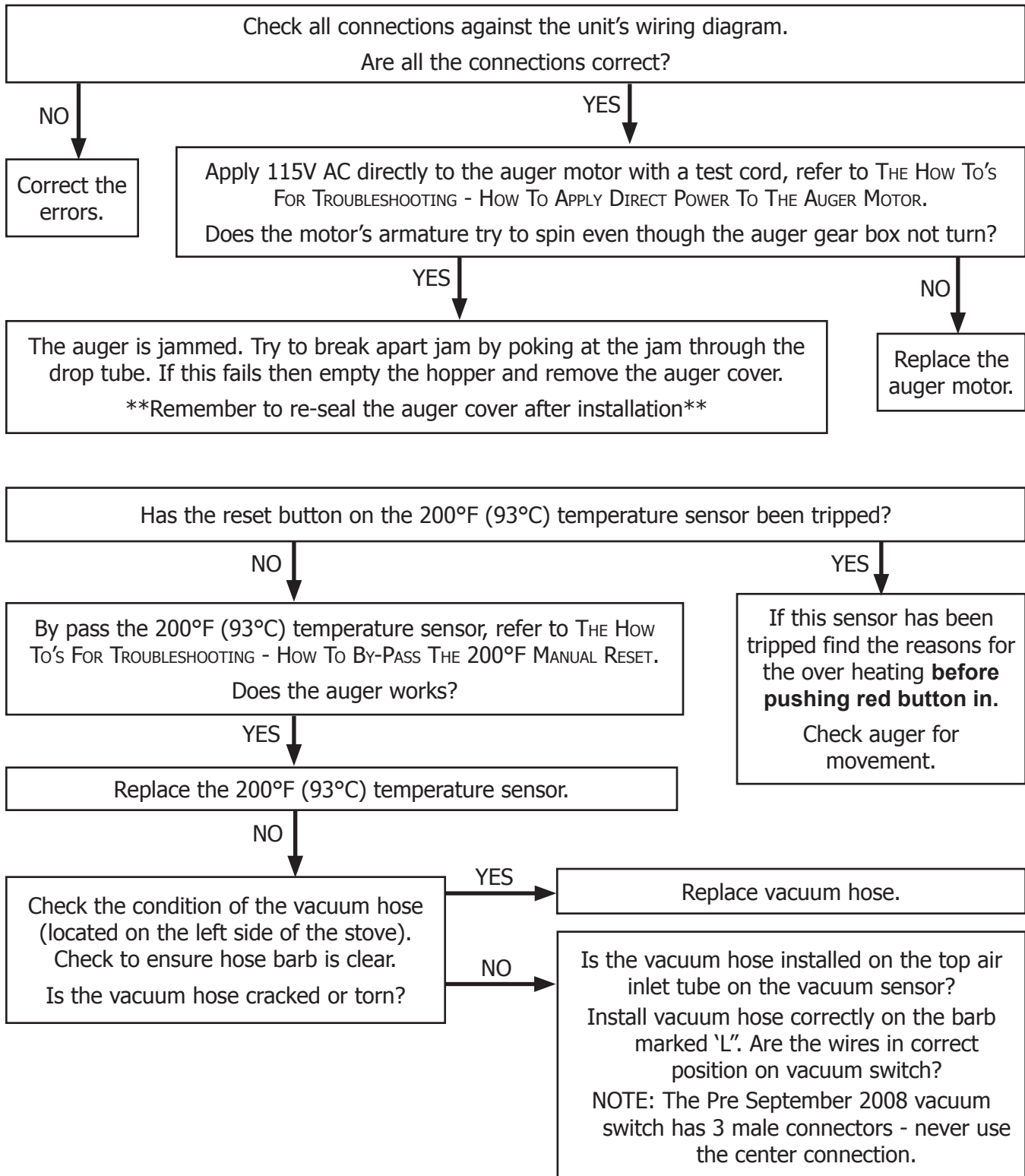

TROUBLESHOOTING

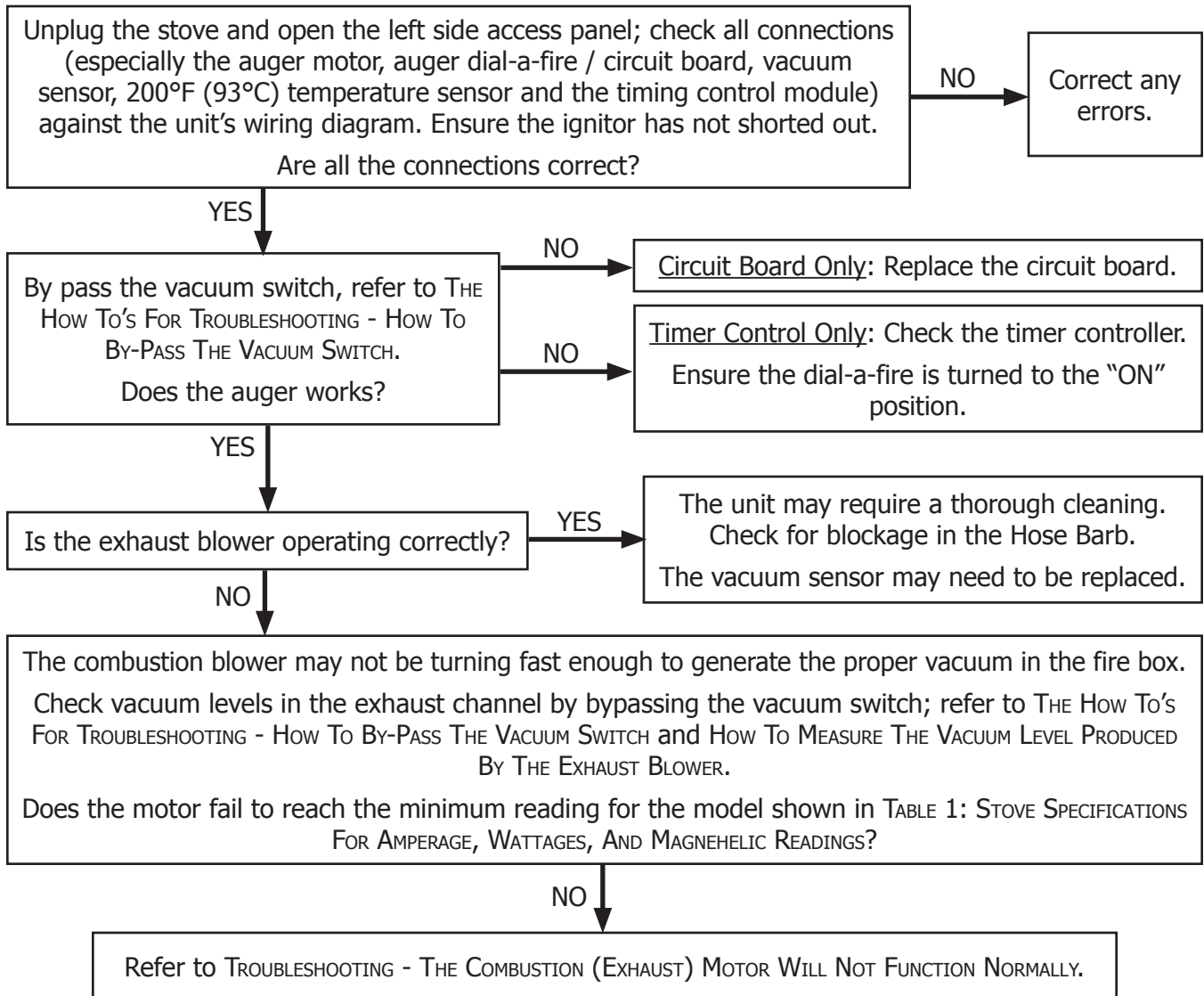

Circuit Board Only: Check the fuses on the circuit board (see "TROUBLESHOOTING - CIRCUIT BOARD FUSES").

THE DIAL-A-FIRE HAS NO EFFECT ON THE FIRE - TIMER CONTROL ONLY:

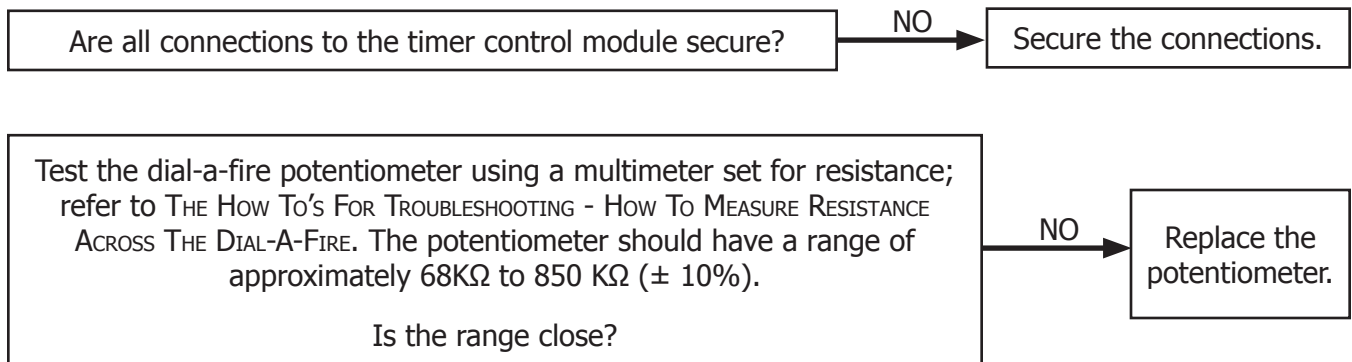

TROUBLESHOOTING

THE AUGER TIMER WILL NOT FUNCTION NORMALLY - TIMER CONTROL ONLY:

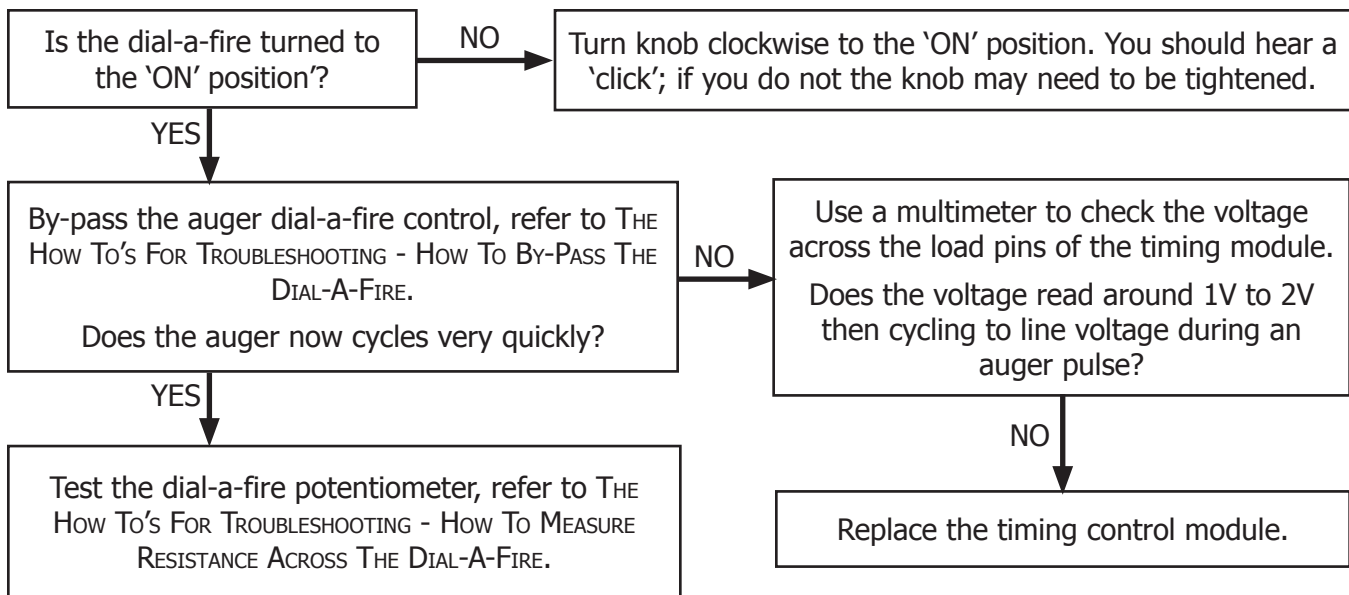

Refer to TROUBLESHOOTING - THE DIAL-A-FIRE HAS NO EFFECT ON THE FIRE .

THE IGNITOR WILL NOT WORK:

Everything else in the stove operates but the ignitor will not light the pellets.

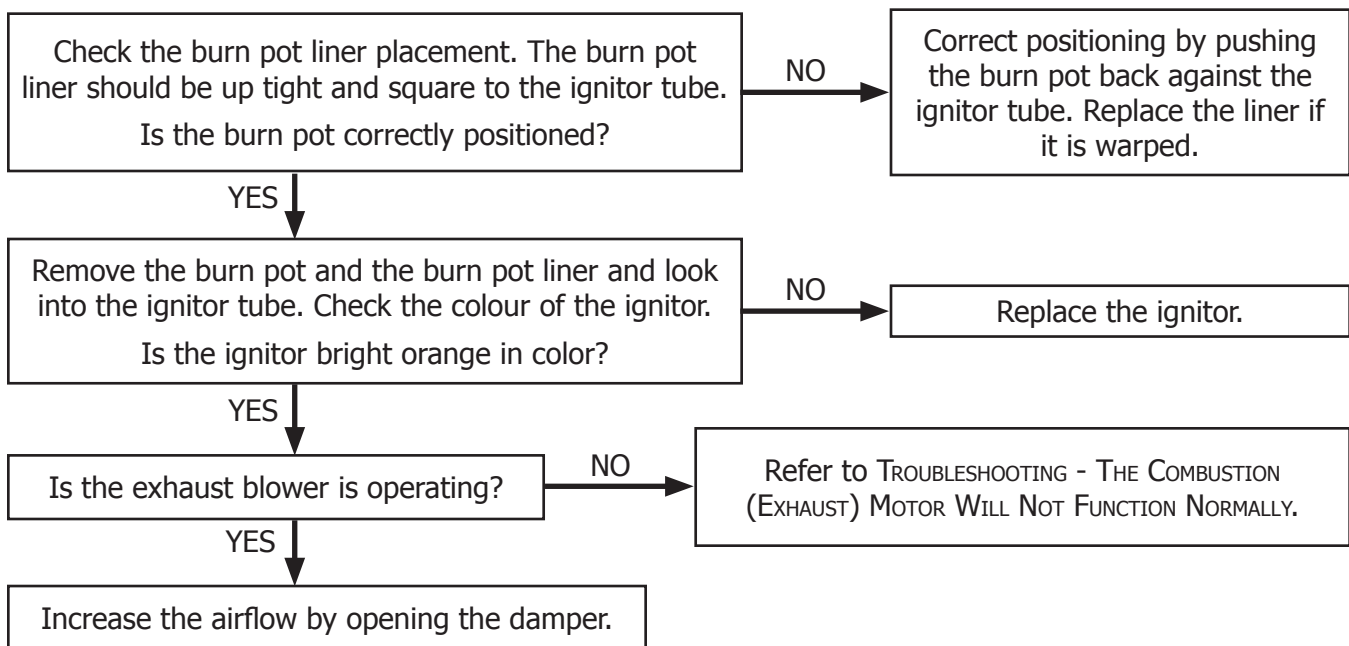

Circuit Board Only: Check the fuses on the circuit board (see "TROUBLESHOOTING - CIRCUIT BOARD FUSES").

TROUBLESHOOTING

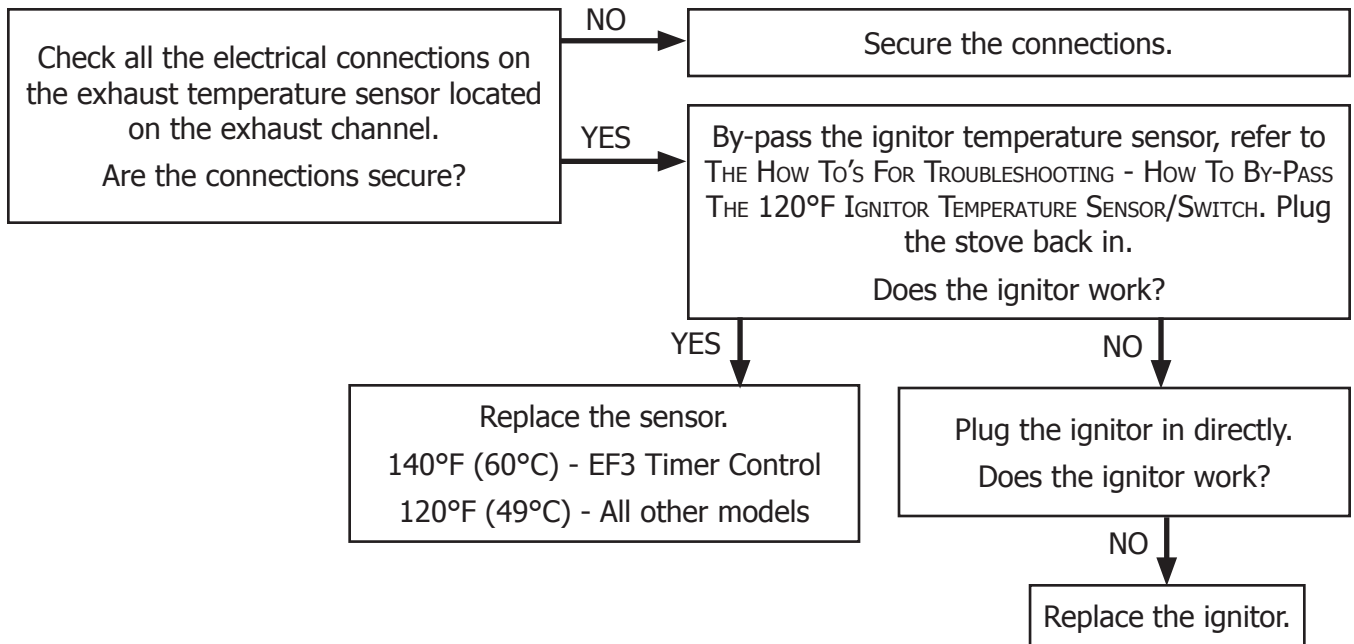

CONTROL SETTINGS (HEAT LEVEL) HAVE NO EFFECT ON THE FIRE - CIRCUIT BOARD ONLY:

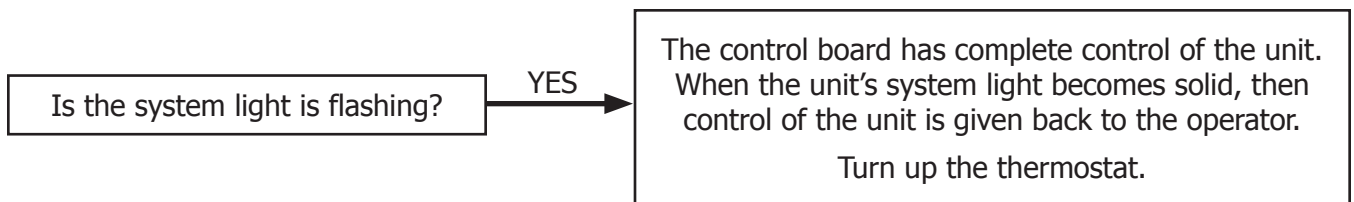

THE STOVE WILL NOT SHUT OFF:

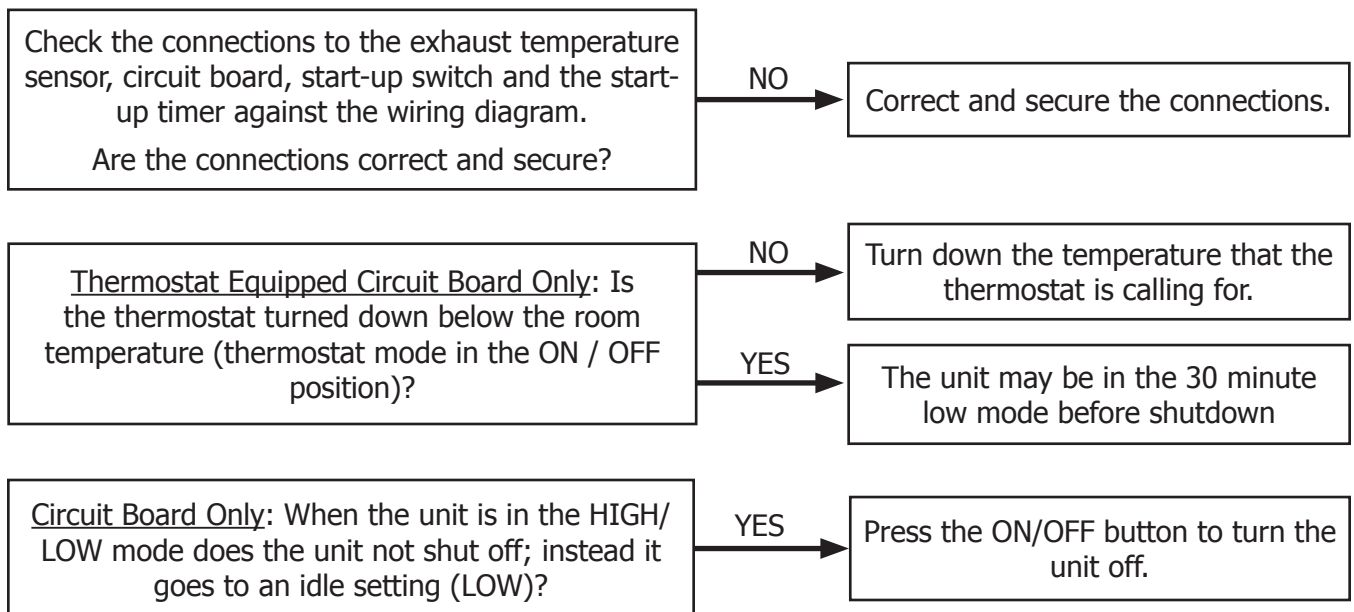

TROUBLESHOOTING

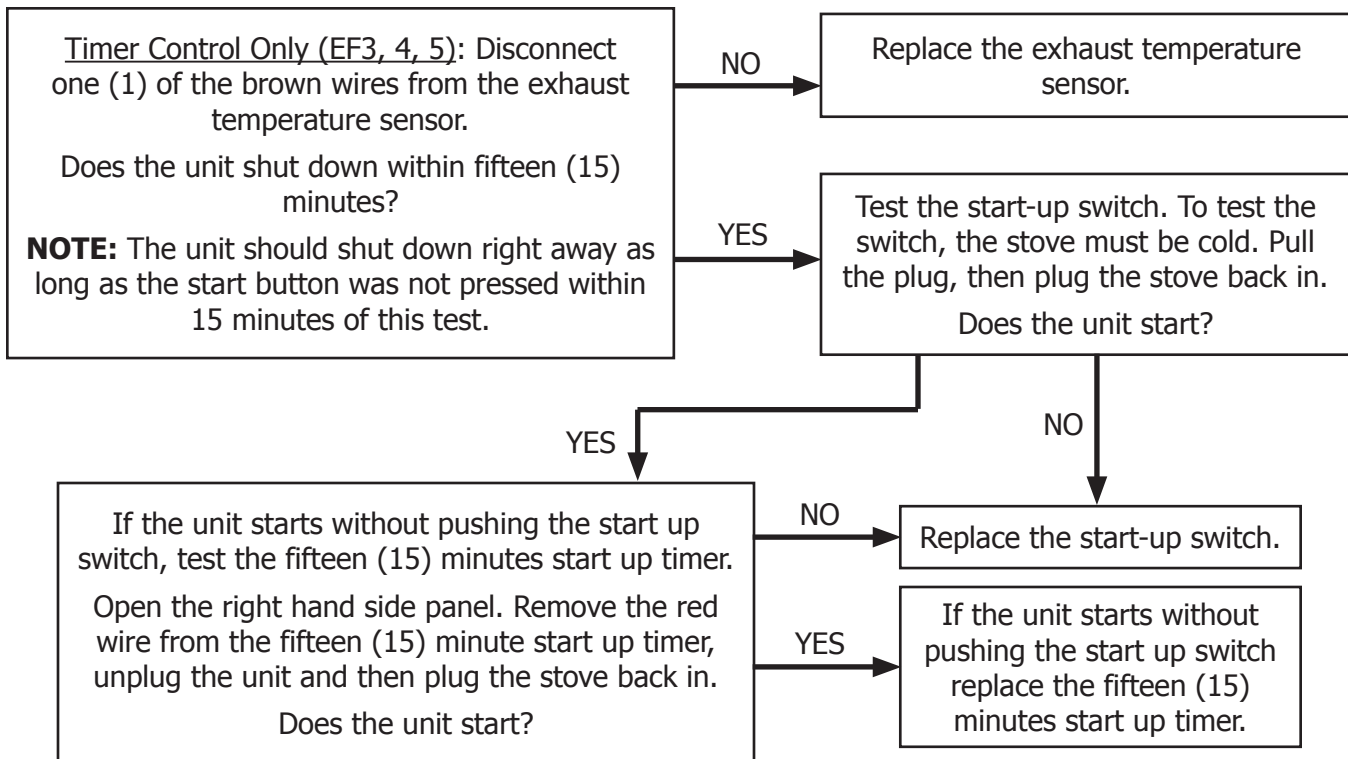
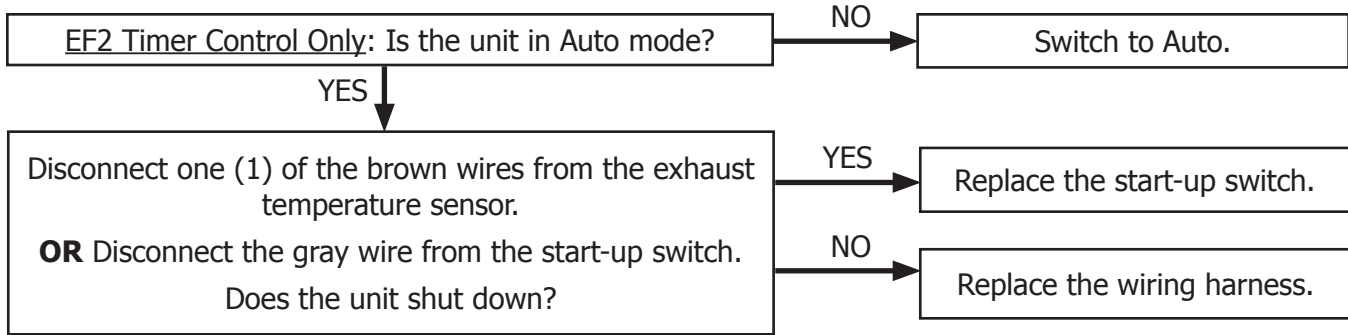

CIRCUIT BOARD FUSES:

This is for the DHC2000 Boards only as the later models have only one fuse that control all functions. F1 is the fuse to the inside of the circuit board controls. F2 fuse closest fuse to the outside edge of the circuit board controls.

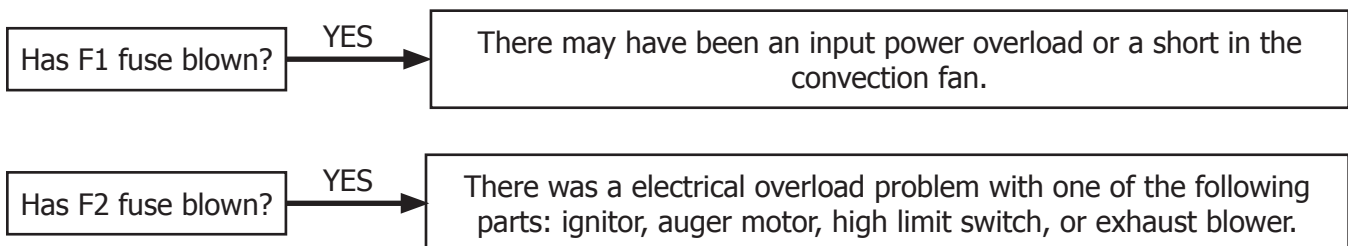

TROUBLESHOOTING

THE STOVE KEEPS GOING OUT:

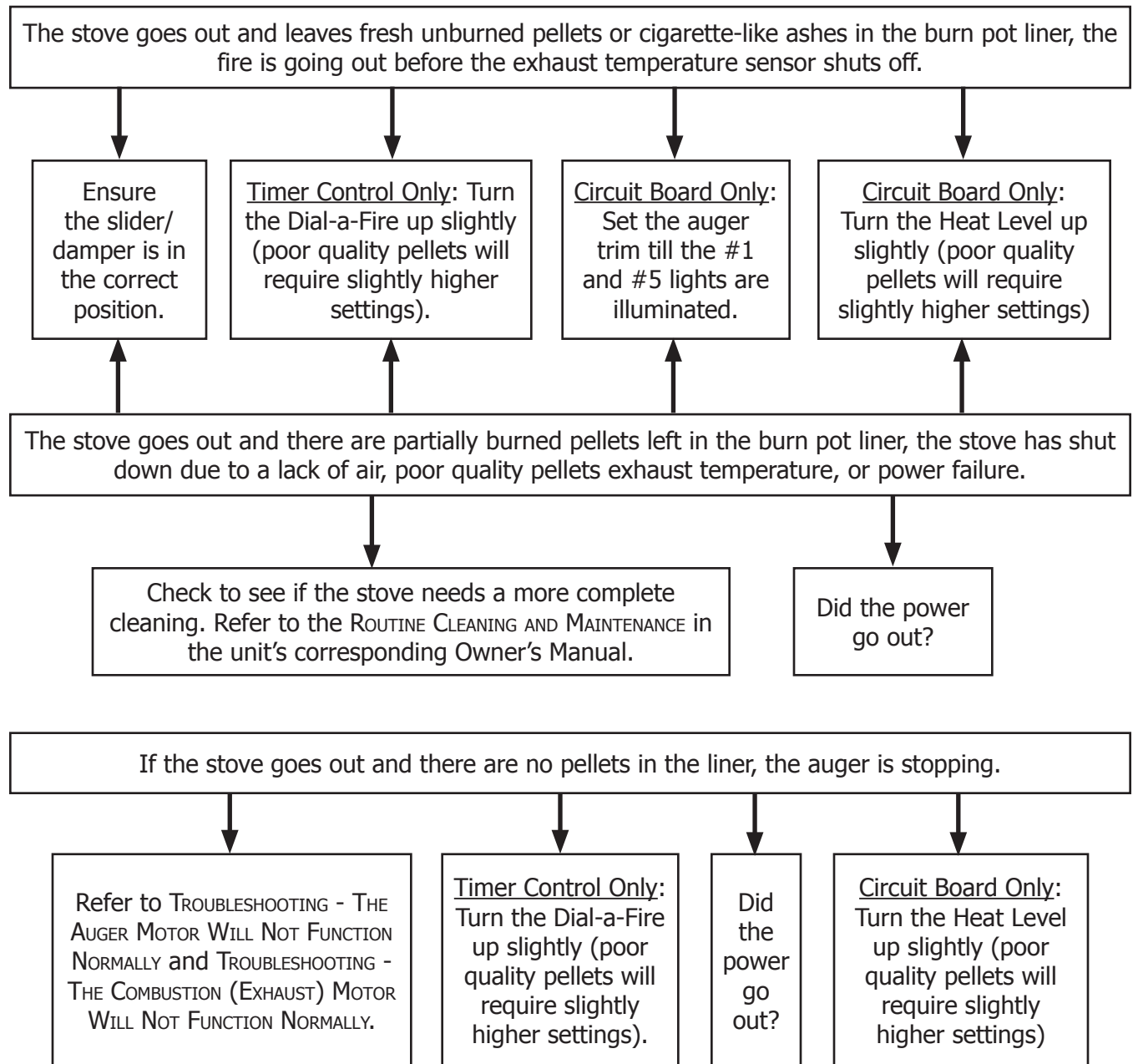

THE AUGER LIGHT FLASHES BUT THE AUGER DOES NOT TURN AT ALL:

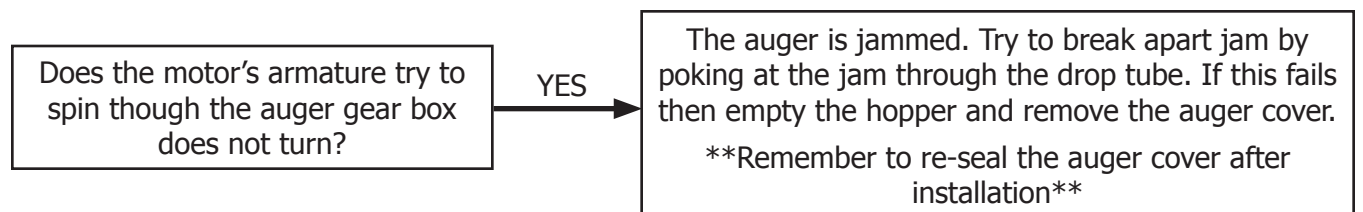

TROUBLESHOOTING

THE AUGER LIGHT FLASHES BUT THE AUGER DOES NOT TURN AT ALL:

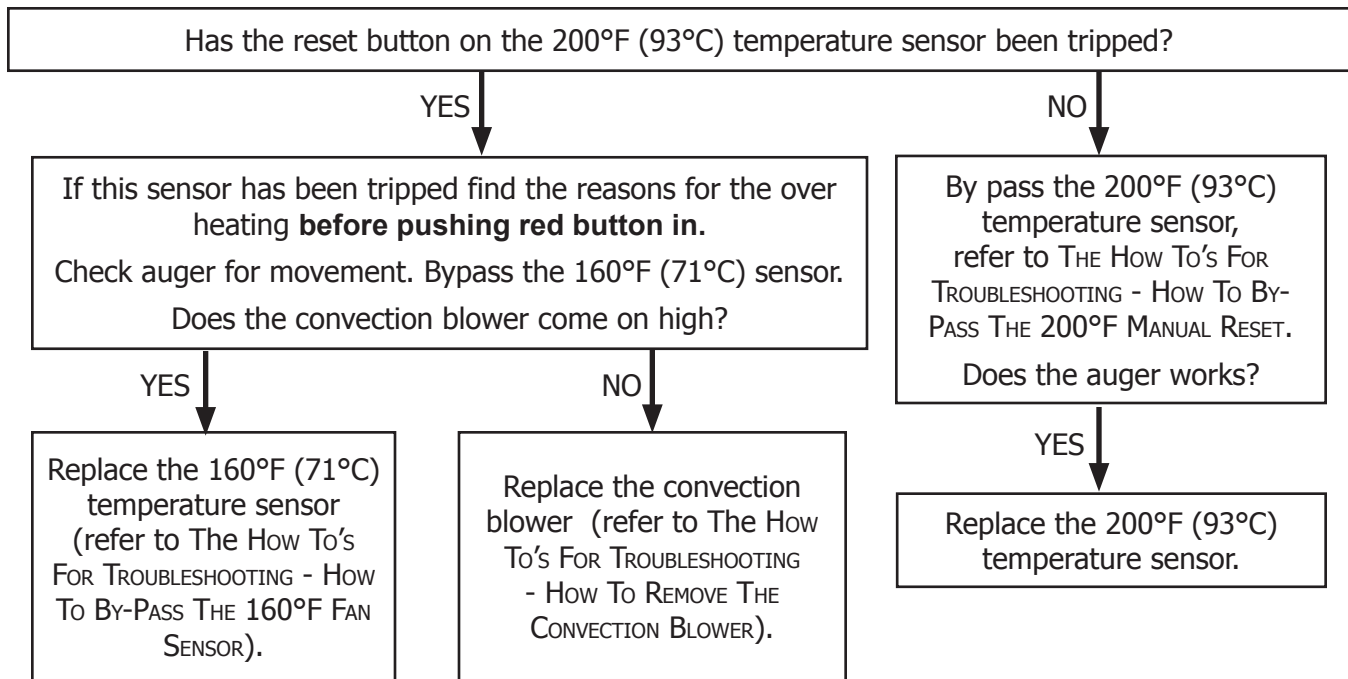

LIGHT #2 ON HEAT OUTPUT BAR FLASHING - CIRCUIT BOARD ONLY:

If light #2 on the heat output bar is flashing, the vacuum switch contacts have been open for more than fifteen (15) seconds.

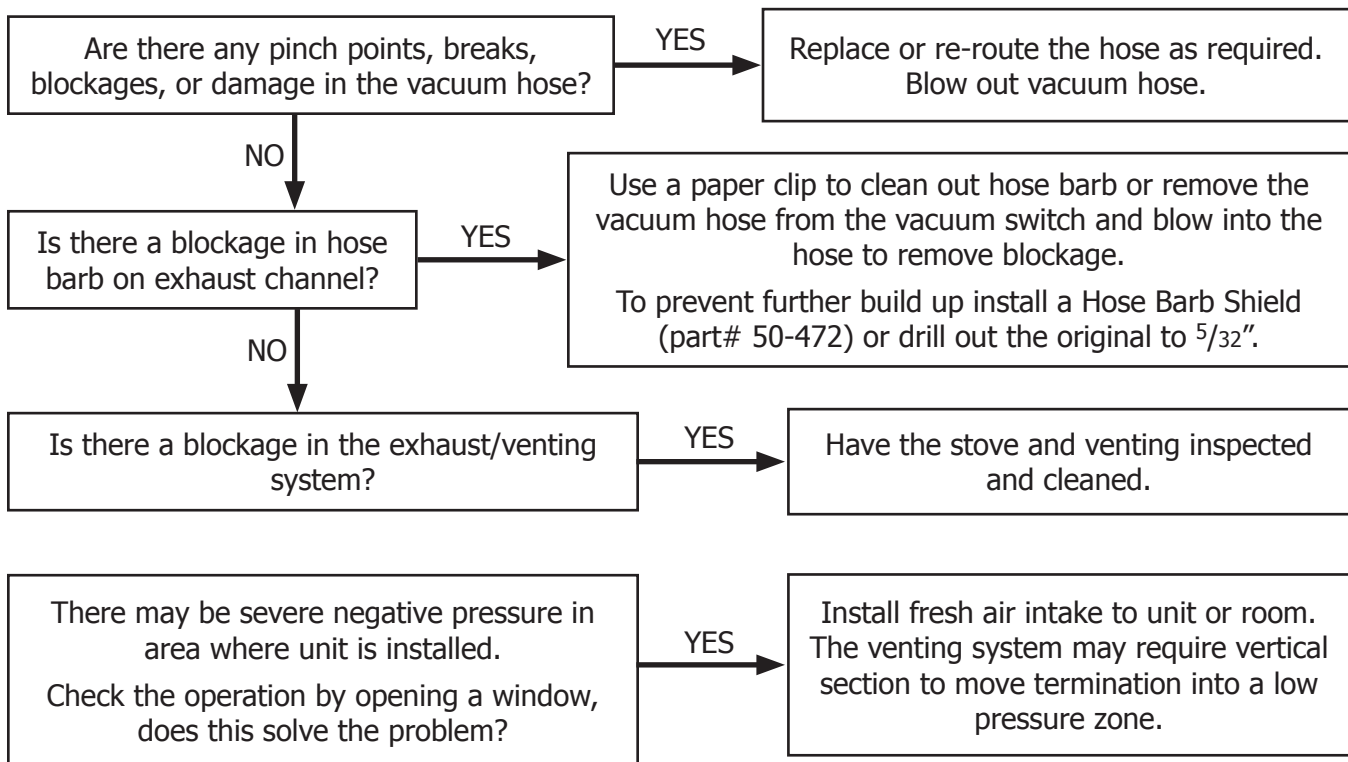

TROUBLESHOOTING

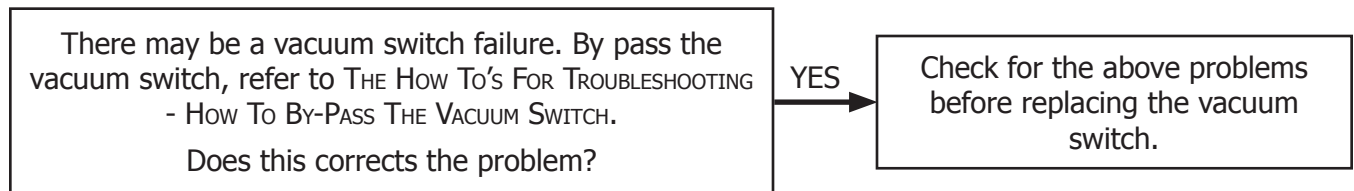
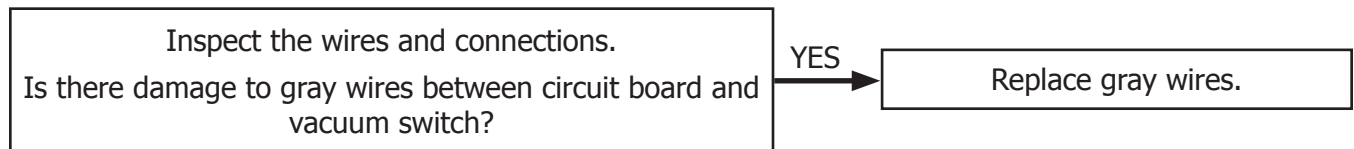
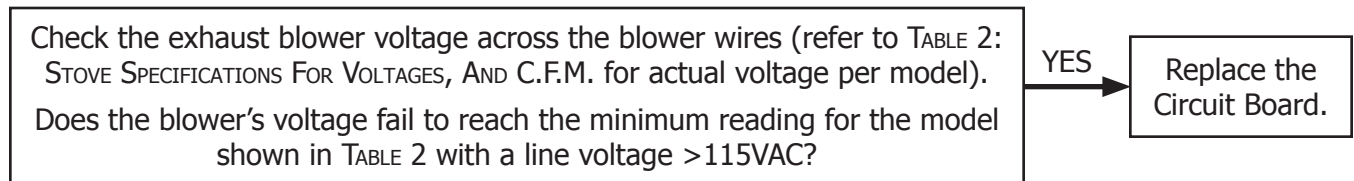
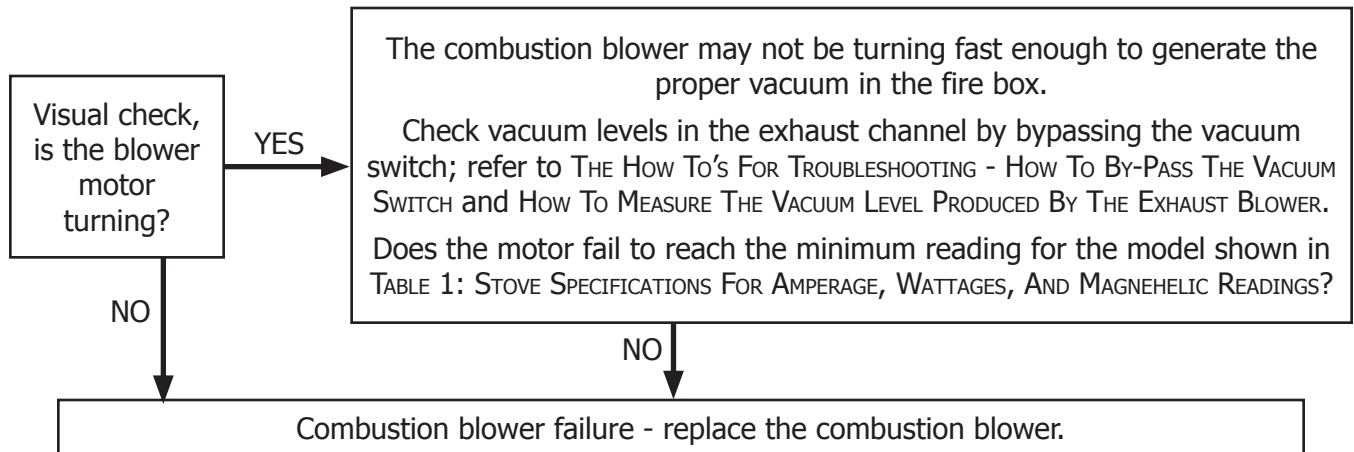

Refer to TROUBLESHOOTING - THE COMBUSTION (EXHAUST) MOTOR WILL NOT FUNCTION NORMALLY & TROUBLESHOOTING - THE AUGER MOTOR WILL NOT FUNCTION NORMALLY .

LIGHT #3 ON HEAT OUTPUT BAR FLASHING - CIRCUIT BOARD ONLY:

If light #3 on the heat output bar is flashing, the exhaust temperature sensor contacts have been opened.

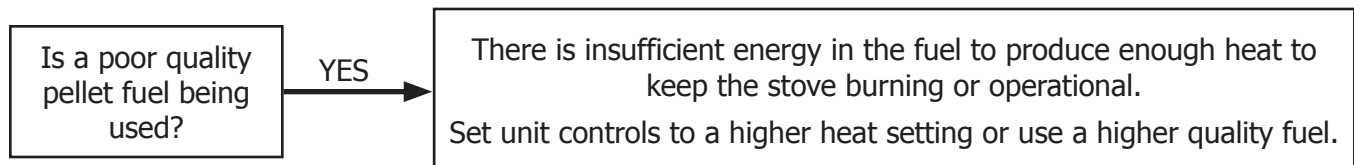
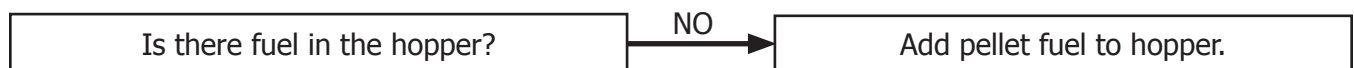

TROUBLESHOOTING

Has the exhaust temperature sensor failed? YES → Replace the exhaust temperature sensor.

Visual check, is the blower motor turning? YES →

The combustion blower may not be turning fast enough to generate the proper vacuum in the fire box.

Check vacuum levels in the exhaust channel by bypassing the vacuum switch; refer to THE HOW TO'S FOR TROUBLESHOOTING - HOW TO BY-PASS THE VACUUM SWITCH and HOW TO MEASURE THE VACUUM LEVEL PRODUCED BY THE EXHAUST BLOWER.

Does the motor fail to reach the minimum reading for the model shown in TABLE 1: STOVE SPECIFICATIONS FOR AMPERAGE, WATTAGES, AND MAGNEHELIC READINGS?

NO ↓

NO ↓

Combustion blower failure - replace the combustion blower.

Is the air damper setting incorrect? YES →

Unit may require a change to the vent system or installation of fresh air to correct air to fuel ratio problems.

Adjust the slider damper using a magnehelic to set it.

Excessive air may consume the fire too quickly before the next drop of fuel, leaving completely unburned fuel in the burn pot liner.

Insufficient air will cause build up, further restricting the air flow through the burn pot liner. This in turn will cause the fuel to burn cold and very slowly. Fuel may build up and smother the fire.

Check the exhaust blower voltage across the blower wires (refer to TABLE 2: STOVE SPECIFICATIONS FOR VOLTAGES, AND C.F.M. for actual voltage per model). Does the blower's voltage fail to reach the minimum reading for the model shown in TABLE 2 with a line voltage >115VAC? YES → Replace the Circuit Board.

FLASH CODES ON DHC 4100:

Is the flashing light in the #2 position? YES → There is a vacuum failure (excluding Maxx).

NO ↓

Is the flashing light in the #3 position? YES → There is an exhaust temperature sensor failure.

NO ↓

Is the flashing light in the #4 position? YES → The high limit sensor has been tripped.

FLAME CHARACTERISTICS

A manahelic pressure gauge should used when setting the slider/damper the stove.



Figure 38: Example of a good fire.

With the slider damper set in the **correct** location the flame will be brisk, but not too blowing. The flame will also have a yellow to bright orange appearance. There should also be some small embers or sparks exiting the flame and burn pot liner. This is an efficient flame and is the best for proper operation.

A small blow torch like flame is a result of **too much oxygen** being supplied to the fire. This causes the flame to become very short and brisk with a bright yellow, almost white, flame appearance. There will also be a lot of embers or sparks exiting the flame and burn pot liner.

To fix this condition, close the slider damper until an efficient flame is achieved.

If a tall lazy orange flame with black tips is present, generally this could be a result of **not enough oxygen** to the fireplace or the pellet fuel being used has very high moisture content. Also a trial of smoke will leave the flame and will end up sooting the appliance.

To fix this condition, open the slider damper to let more air to the fire, also make sure the pellet fuel being used is dry.



Figure 39: Example of a fire with too much air.



Figure 40: Example of a fire with not enough air.

WIRING DIAGRAM

EF2 TIMER CONTROL:

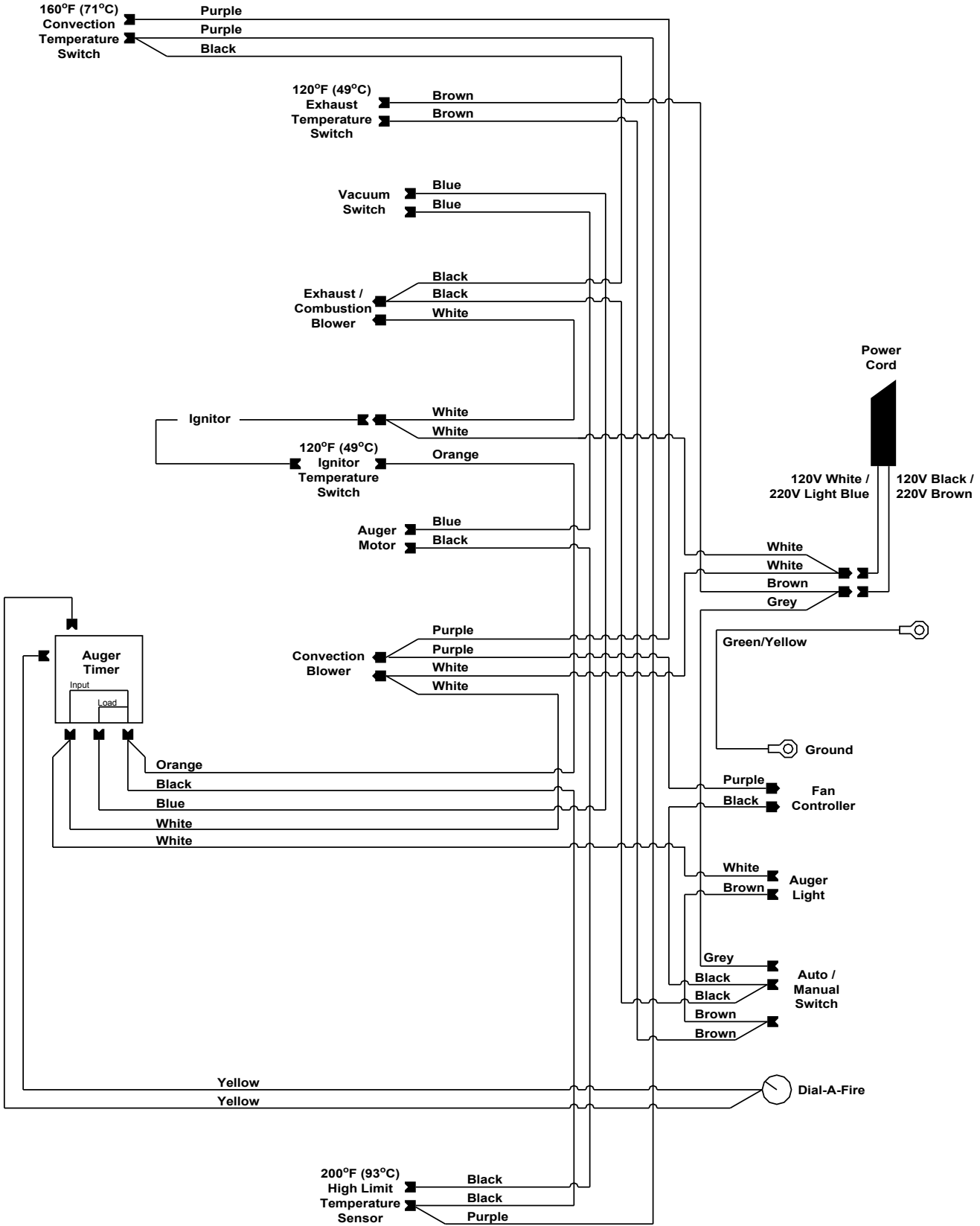

WIRING DIAGRAM

EF3 TIMER CONTROL:

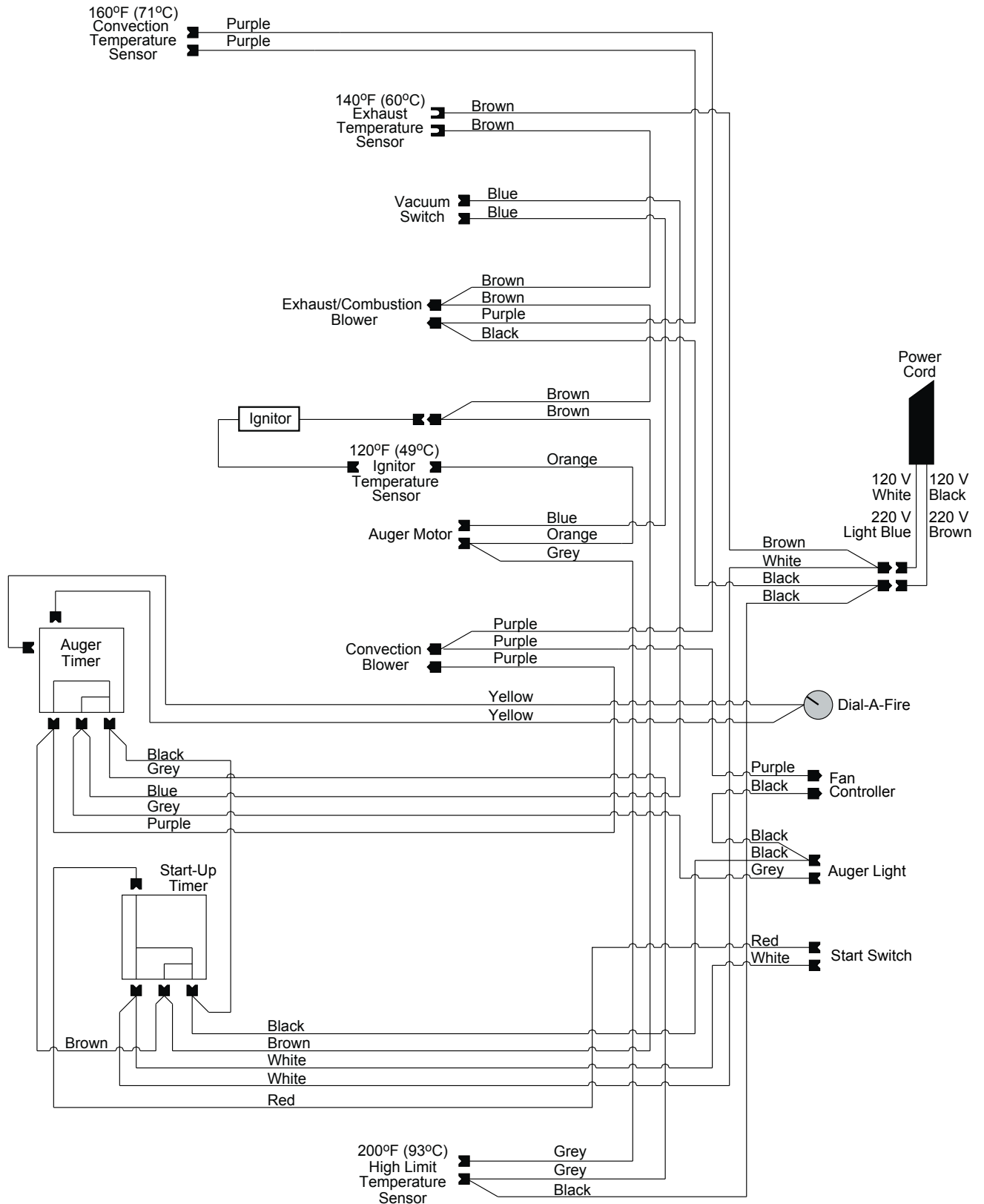

WIRING DIAGRAM

EF2, EF3, & EF4 TIMER CONTROL WITH THERMOSTAT INTERFACE:

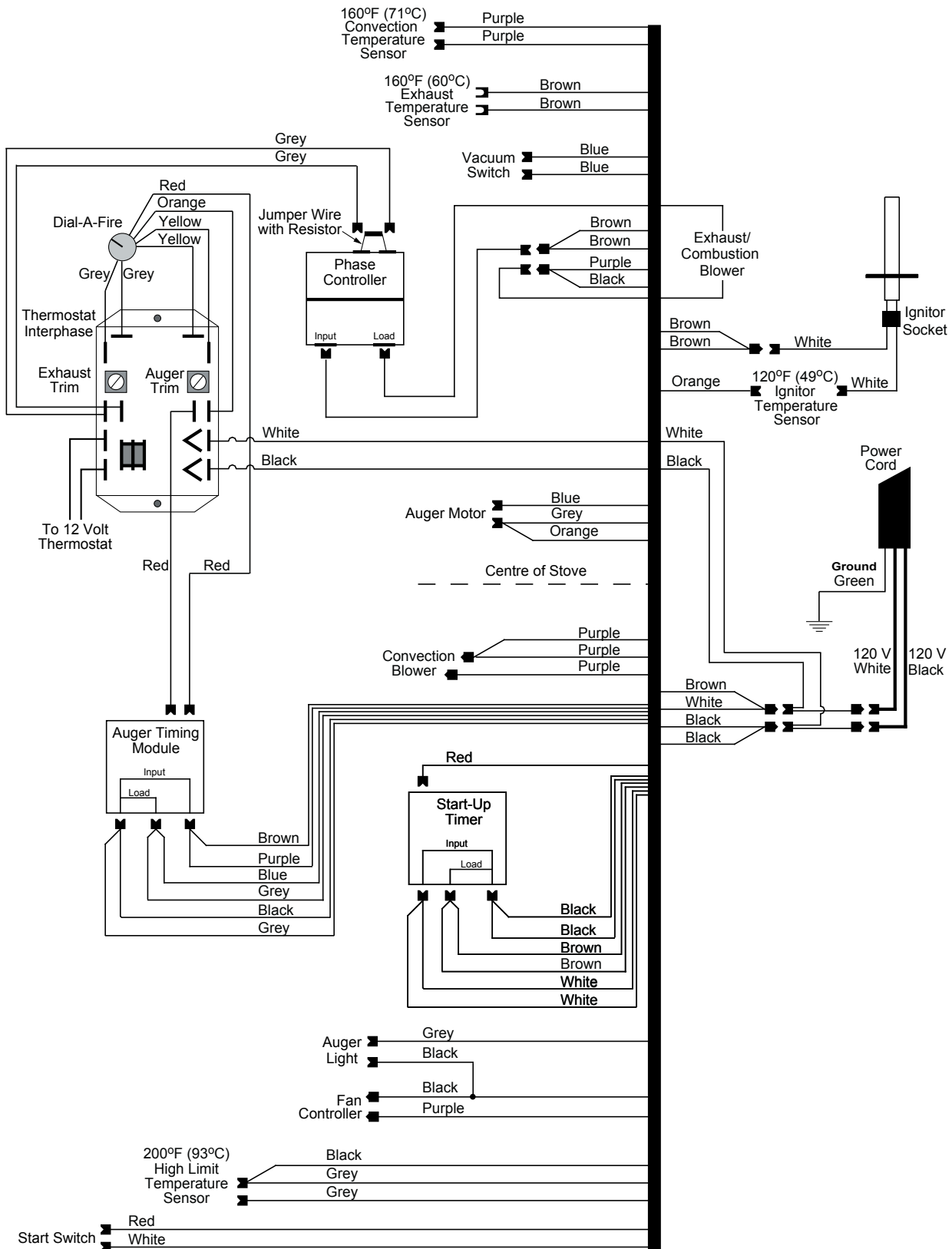

WIRING DIAGRAM

EF4:

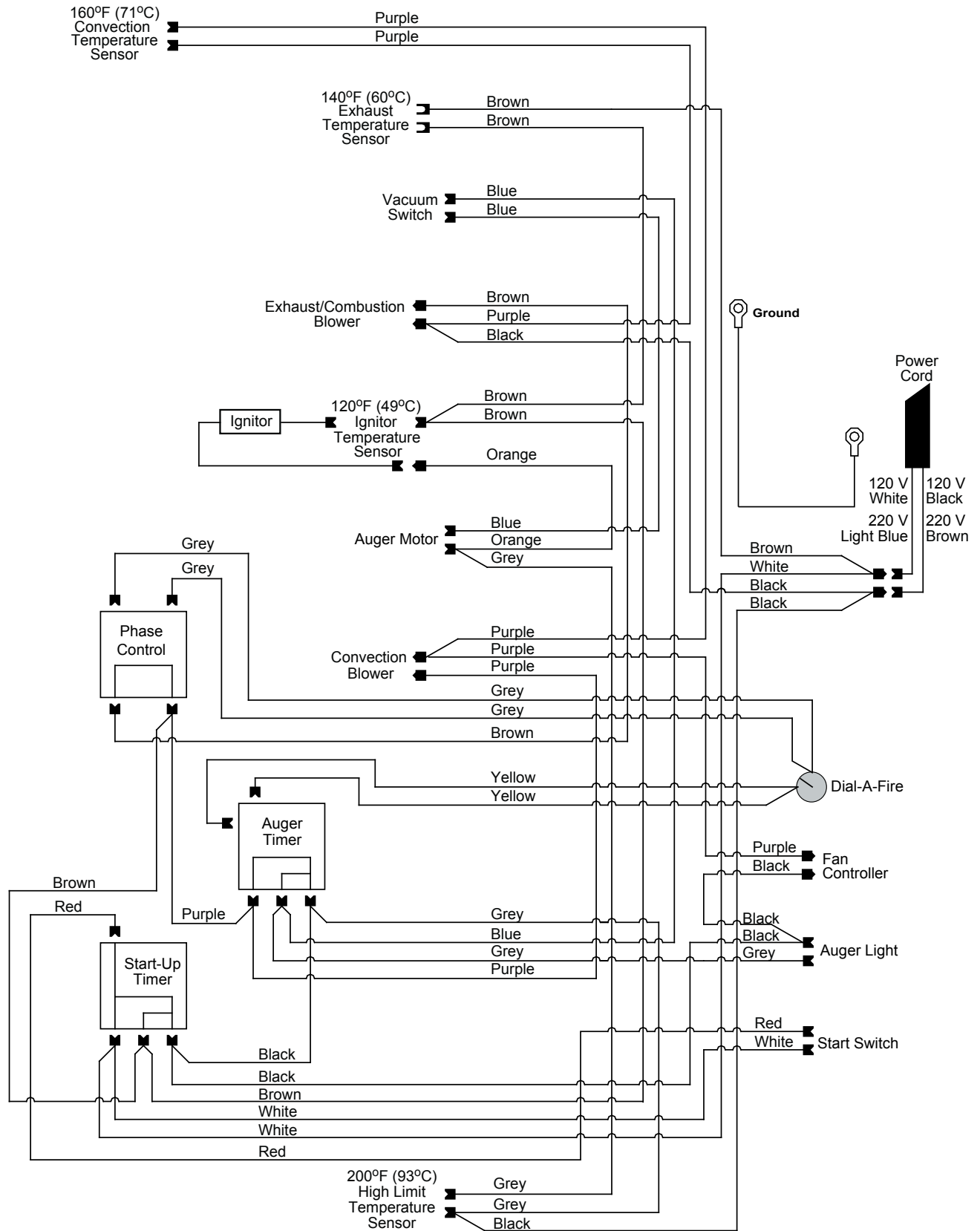

WIRING DIAGRAM

EF5 (EVOLUTION) - TIMER CONTROL:

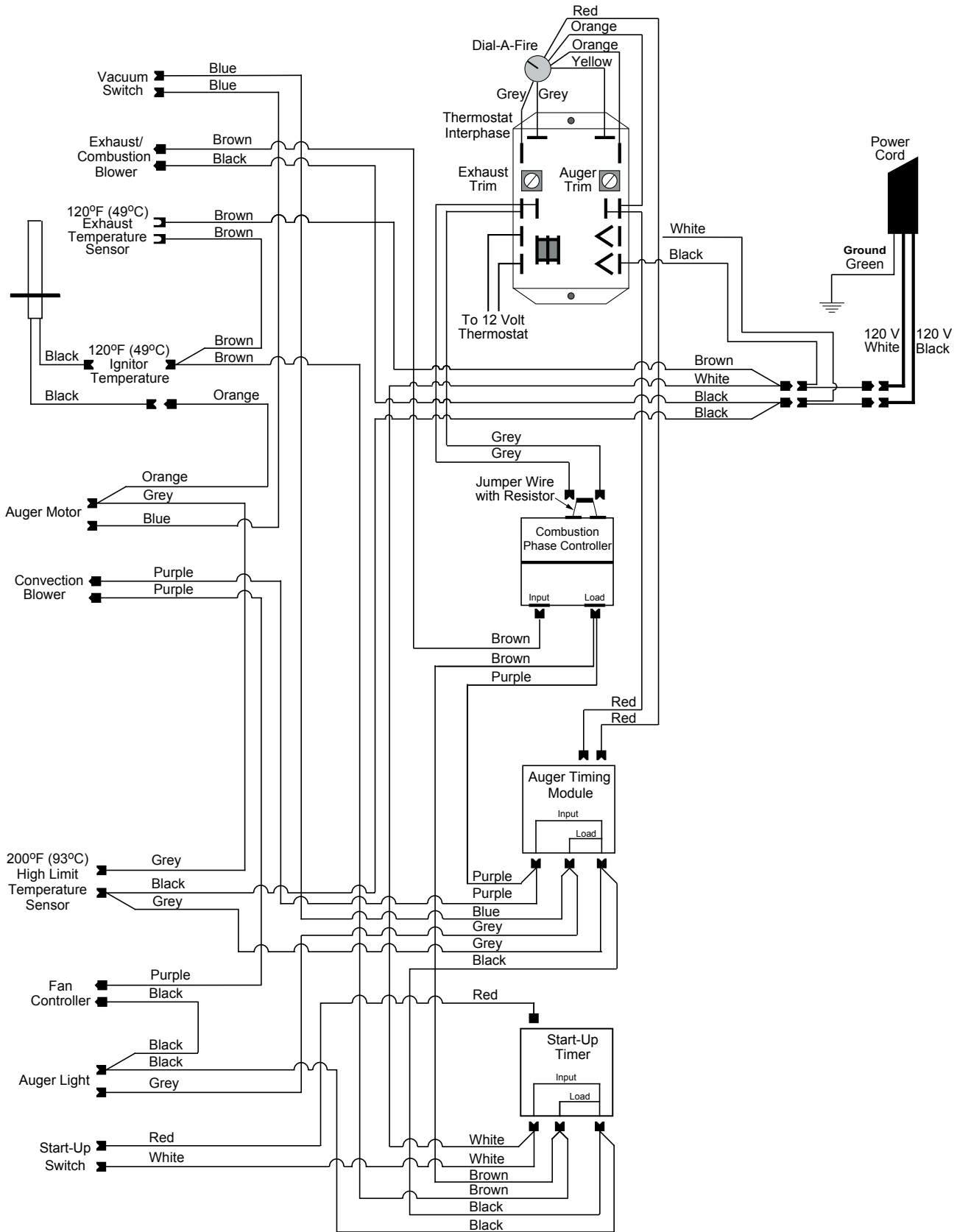

WIRING DIAGRAM

EF5 (EVOLUTION) & MINI - DHC 2000:

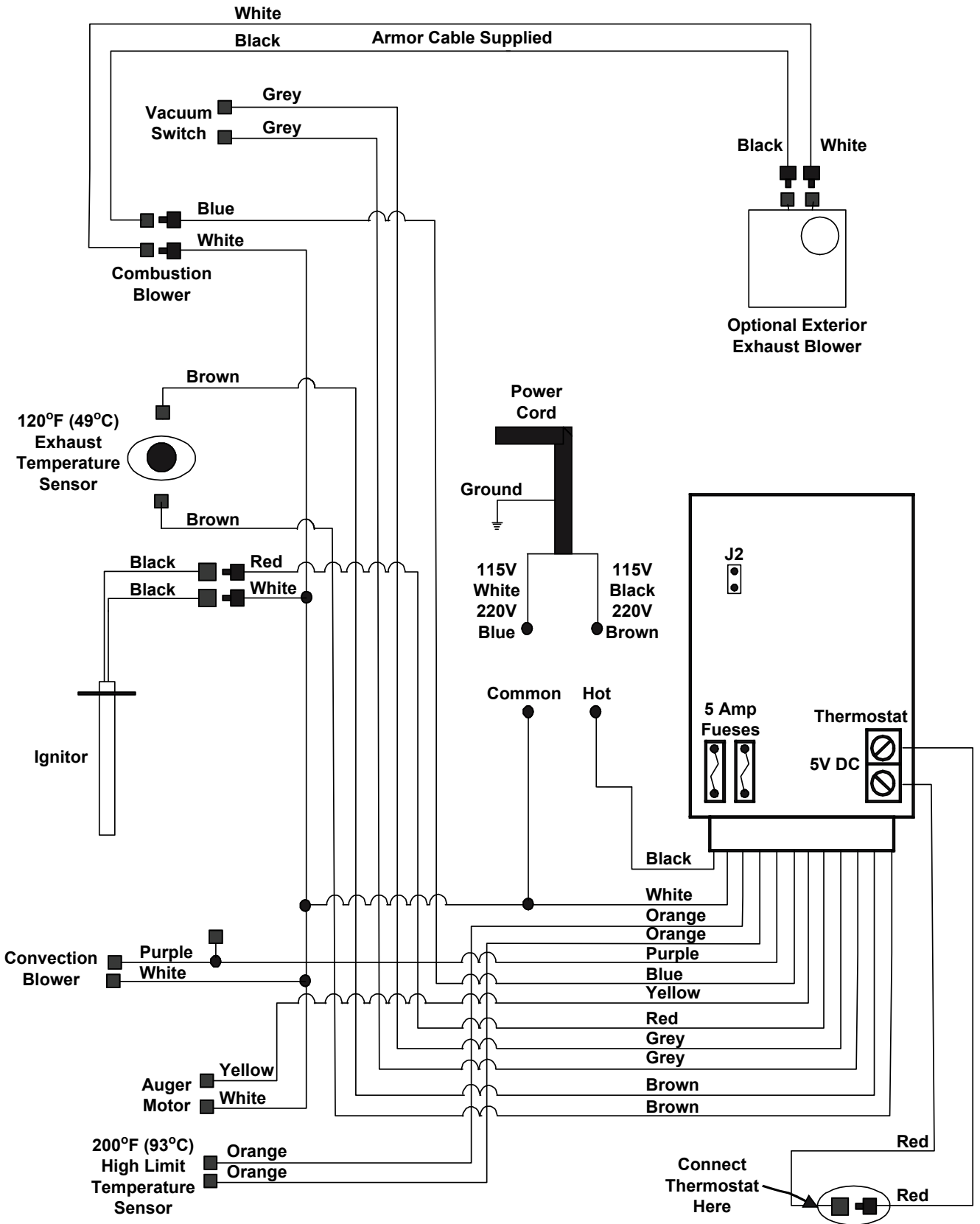

WIRING DIAGRAM

MERIDIAN CIRCUIT BOARD - DHC 2000:

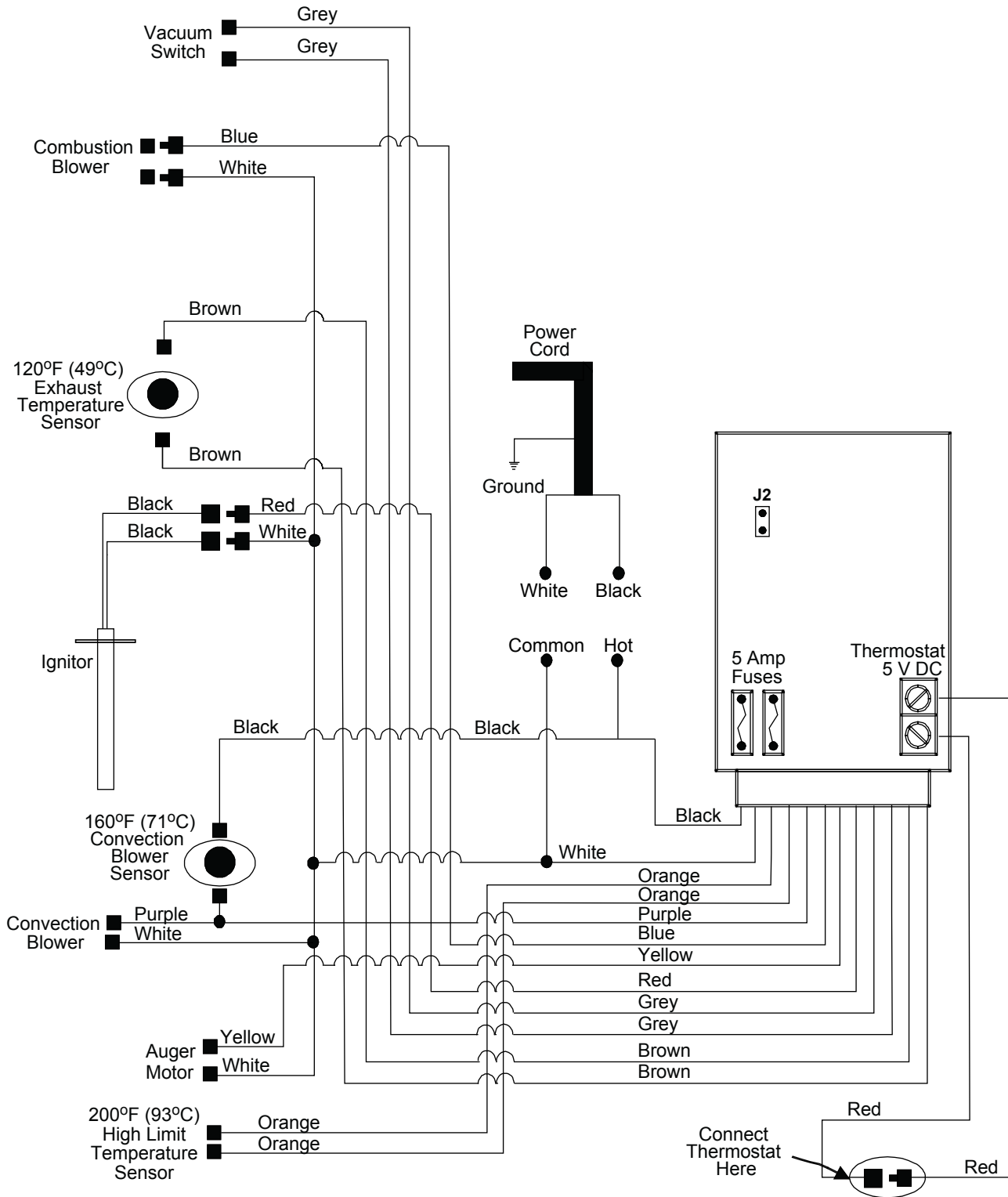

WIRING DIAGRAM

EMPRESS FS - DHC 2000:

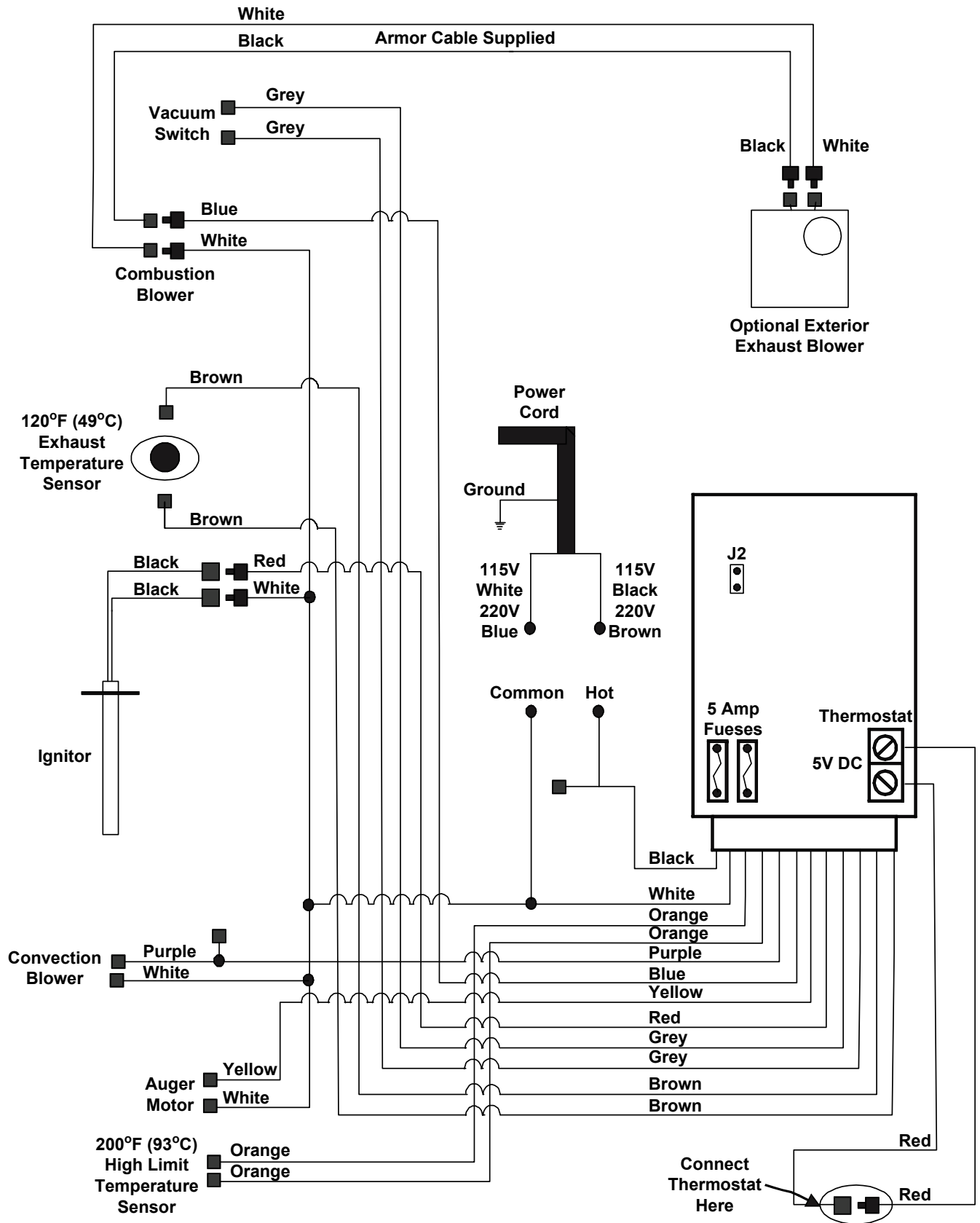

WIRING DIAGRAM

MERIDIAN - DHC 3000, 4000, & 4100:

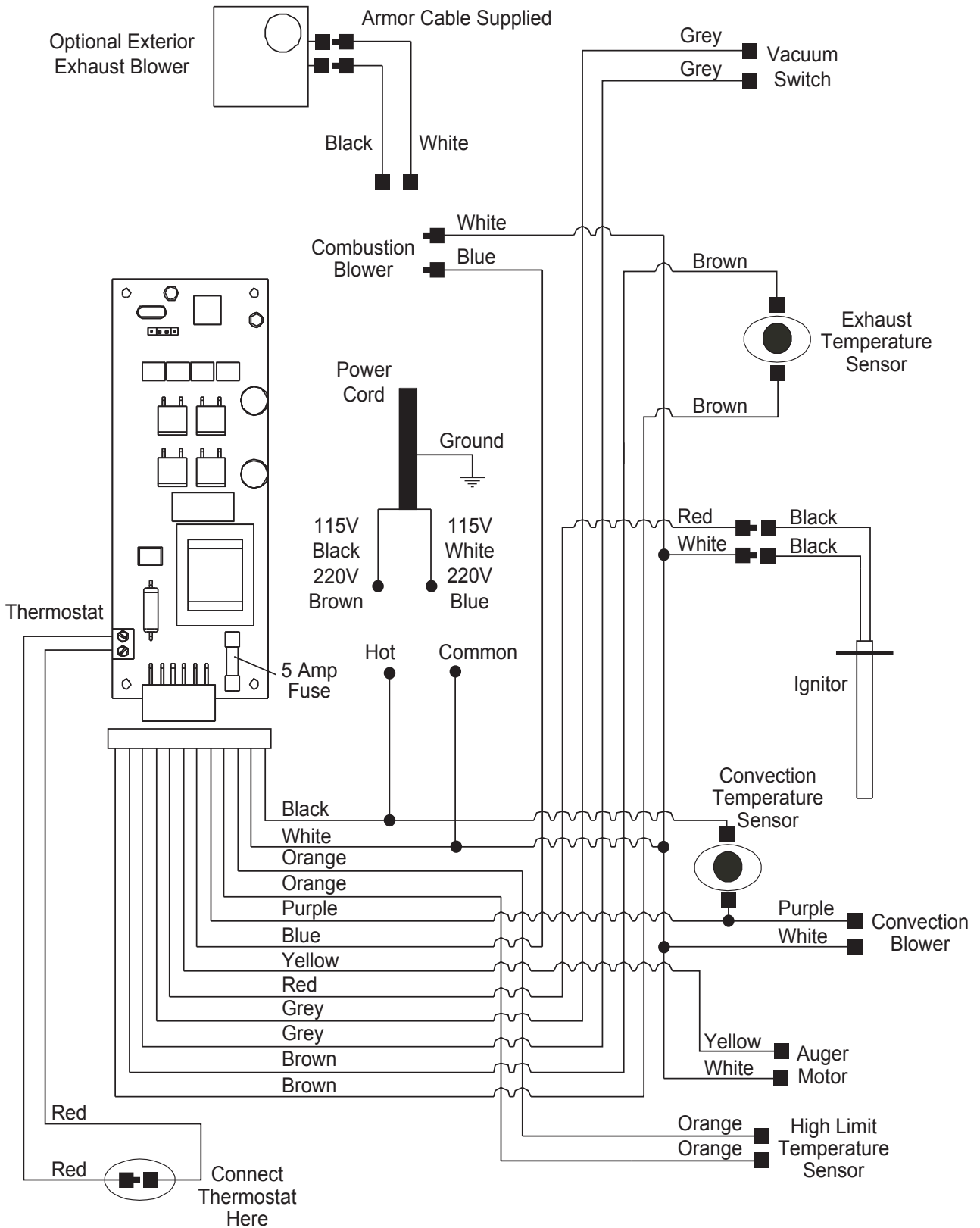

WIRING DIAGRAM

EMPRESS FPI & MILAN:

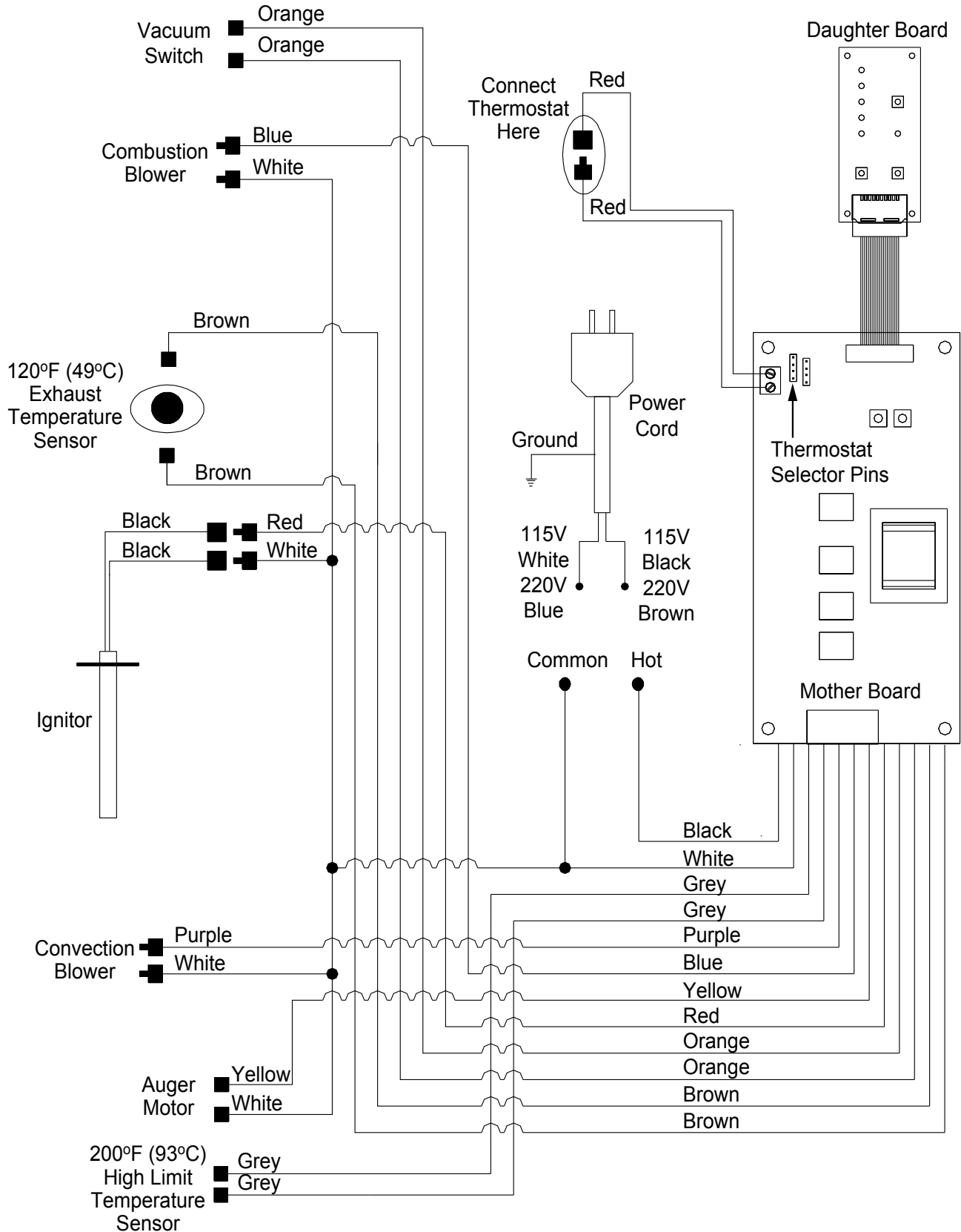

WIRING DIAGRAM

WINDSOR:

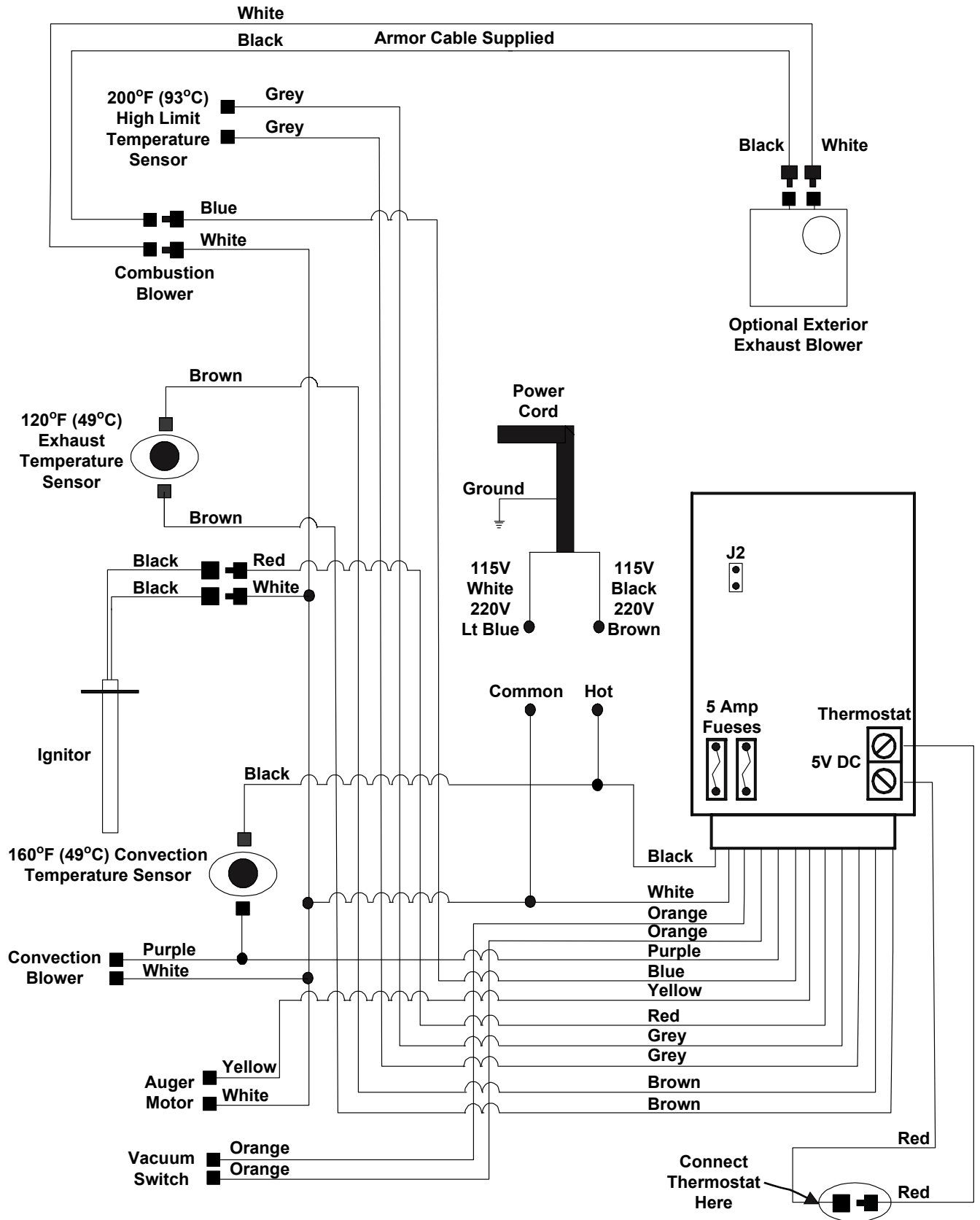

WIRING DIAGRAM

MAXX:

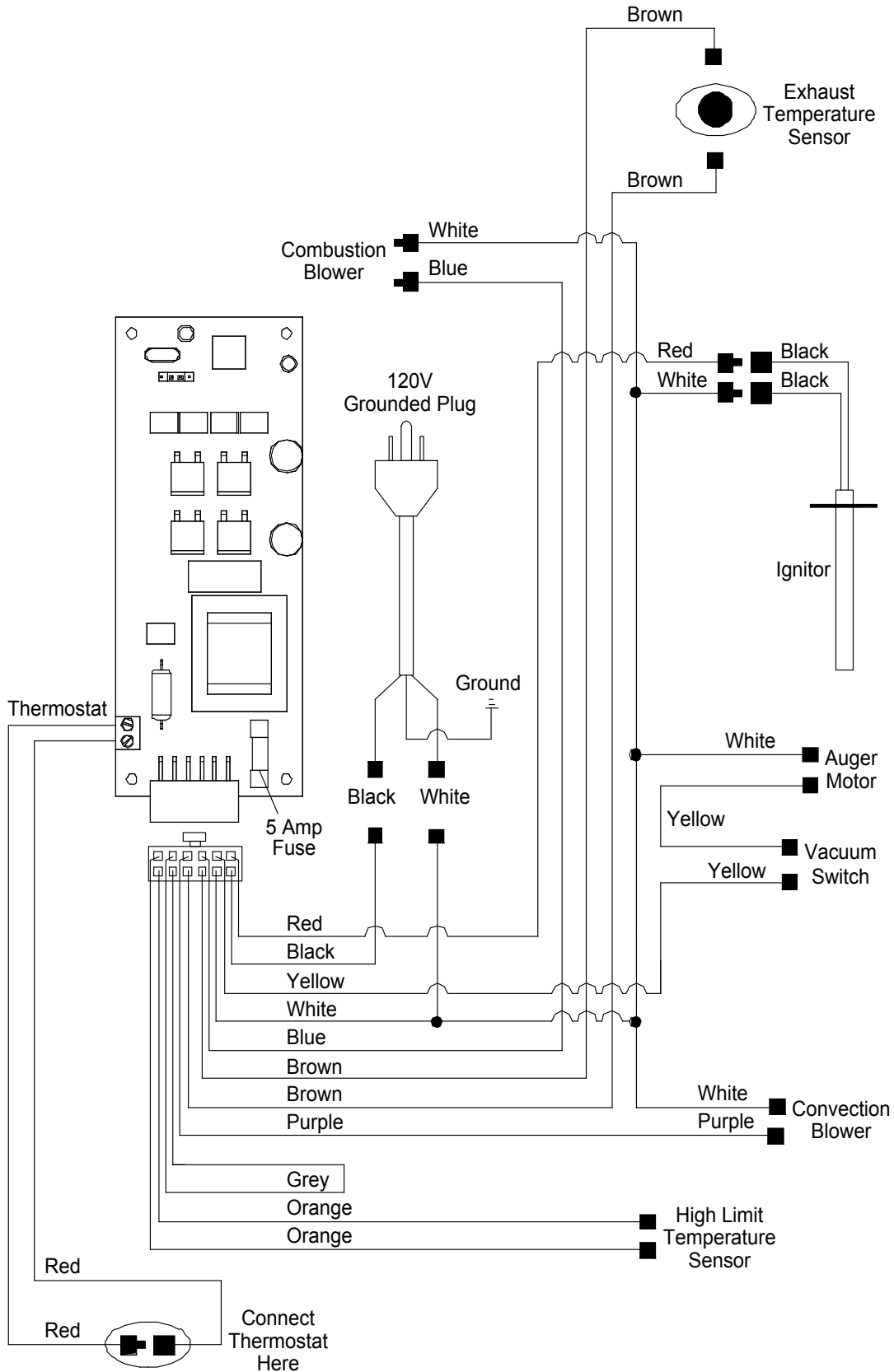

WIRING DIAGRAM

M55-FS - DHC 4110:

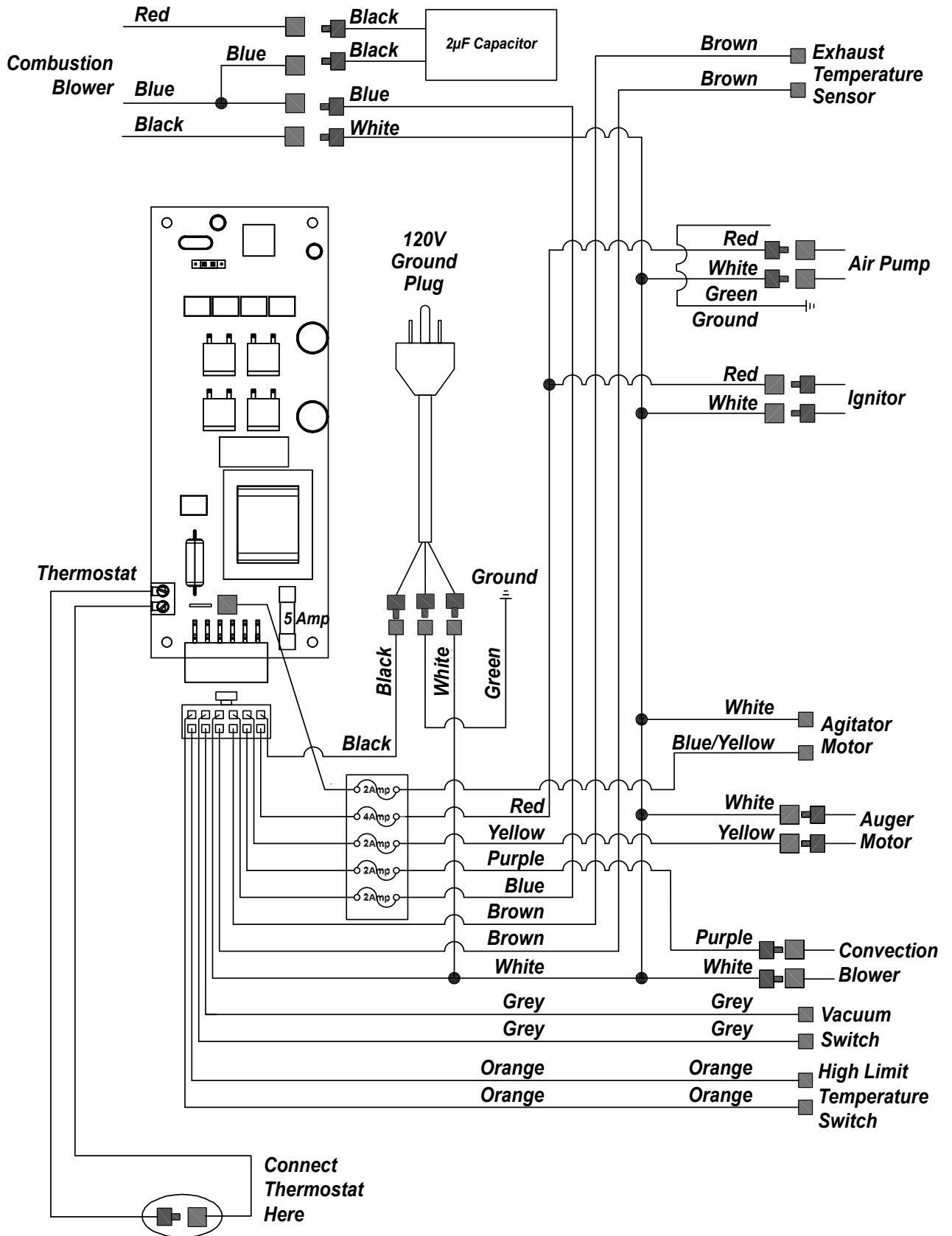

WIRING DIAGRAM

OMEGA:

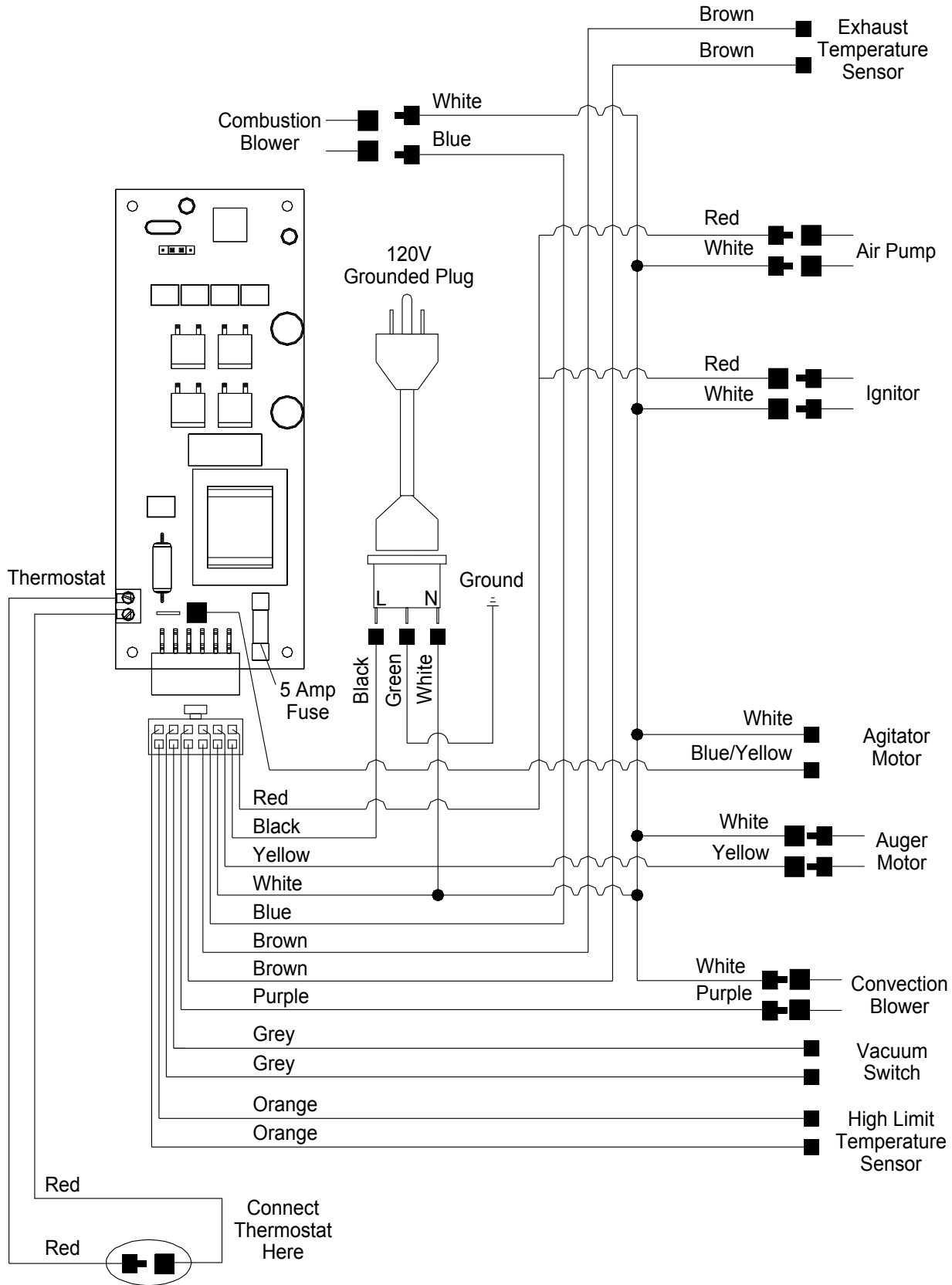

COMPONENTS OF A PELLET STOVE

120°F (49°C) N/C Ignitor Temperature Sensor: This sensor (mounted on the exhaust channel) will turn the ignitor OFF when the exhaust temperature reaches 120°F (49°C). This is a normally closed sensor that opens when it is heated to 120°F (49°C).

160°F (71°C) Convection Fan Sensor: When this sensor mounted on the left side firewall reaches 160°F (71°C) the convection blower will go to high cooling the unit before it overheats.

200°F (93°C) Manual Reset High Limit Temperature Sensor: This sensor (located on the right hand side of the firewall) has a red push button in the center of the sensor. This is a safety device. In the event that the convection blower fails, this sensor will detect the stove might overheat and will shut the power OFF to the auger motor.

Auger And Auger Motor: The 1 rpm auger motor is responsible for turning the auger shaft, which in turn transports pellets to be dropped into the burn pot. The timing control module and the dial-a-fire control the auger motor. This can be checked using 110V AC direct power.

Auto/Manual Switch (EF2 only): This starts the stove in the manual position, when the green light comes on push the switch to the auto position.

Control Board: This device controls the operation of the unit. This device has been designed to fully operate the unit; the control board can change the amount of fuel that delivered to the burn pot as well as room air blower (convection blower) functions. This device is also responsible for turning the unit ON and OFF. This control board can be operated manually or a wall thermostat can be installed on this unit as well.

Convection Blower: This blower mounted on the right hand side of the stove draws room air from the back of the stove and passes the air through the heat exchanger tubes and back into the room. The sealed system keeps the room air separate from the combustion air. The fan controller controls this fan. This can be checked using 110V AC direct power.

Convection Fan Controller: This controller is responsible for varying the speed of the convection blower. The stove does have a fan control override. Should the convection blower be set on low and the dial-a-fire set on high, the convection blower will by-pass the fan controller and go to high speed. This will cool the stove until control is given back to the fan controller. To eliminate the possibility of the fan cycling the fan controller and the dial-a-fire should be set proportionately to one and other. The controller can cause the fan to have low speed rumble if the output voltage is too low.

Combustion/Exhaust Blower: This fan mounted on the left hand side of the stove is responsible for drawing outside fresh air into the combustion chamber for burning. The hot air then continues to be drawn over the heat exchanger tubes and then into the exhaust channel. It is then pushed out through the exhaust system. This can be checked using 110V AC direct power.

Dial-a-fire (Heat Output Control): This unit is responsible for controlling the timing of the auger motor. When turned clockwise it will cause the OFF time between auger pulses to shorten, resulting in more heat output and pellet consumption. Turn the counter-clockwise and the reverse will happen. When it is turned fully counter-clockwise until it clicks the auger will stop. This can be checked using an ohm meter.

COMPONENTS OF A PELLET STOVE

Exhaust Temperature Sensor: This sensor is normally open, is mounted on the exhaust blower housing, and has two functions:

1. Should the fire go out, this sensor will shut the stove off when the exhaust temperature drops below its set point.
2. When the auger is turned OFF via the dial-a-fire, the exhaust temperature will drop, when the exhaust temperature drops below set point the sensor will shut the stove OFF.

Green Light: For EF 3 & 4 this light will flash in conjunction with the pulses of the auger. For the EF2 the light signals you to put the stove into the auto position.

Ignitor: A heating element used to ignite the pelletized fuel when the start-up switch is activated; the ignitor is activated by the start-up timer. Air passes through the ignitor tube, which the air becomes super heated drying the fuel and then igniting the fuel through convection.

Phase Controller (EF4): The EF 4 has a phase controller which is responsible for reducing the speed of the combustion/exhaust blower as the dial-a-fire is turned down to a lower flame setting, this will decrease the air flow through the appliance helping the stove run more efficiently.

Start-Up Switch (EF 3 & 4): When this switch is pressed it will initiate a start-up timer including the ignitor if installed in the unit.

Start-Up Timer (EF 3 & 4): This start-up timer bypasses the exhaust temperature sensor allowing the stove to operate when the unit is cold. The timing cycle is initiated by pressing the start-up switch. The start-up timer is located right under the timing control module on the right hand side rear pillar. This is also responsible for turning the ignitor ON.

Timing Control Module: The timing control module is mounted above the start-up timer located on the right rear support pillar. This module controls the switching of power to the auger. The timing control modules switching duty is controlled by the dial-a-fire.

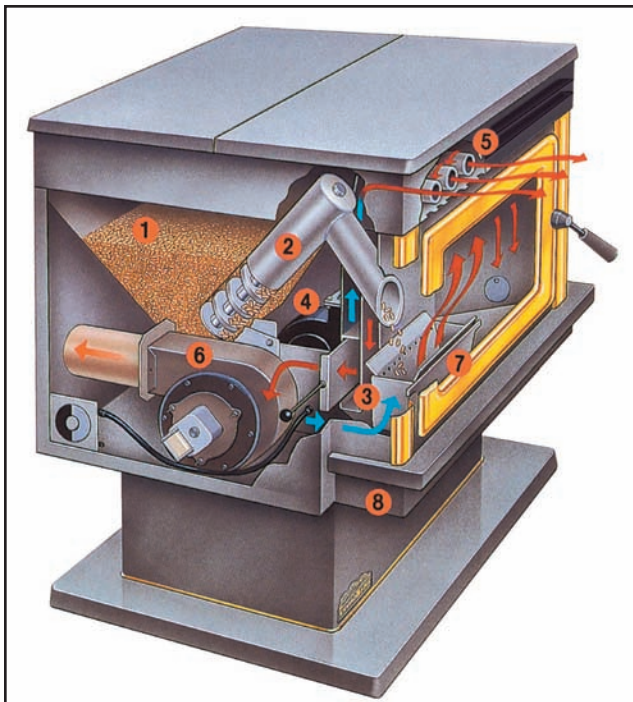

Figure 40: Major Components of our Pellet Stoves.

Vacuum Switch: This safety device (located on the left rear support pillar) detects vacuum in the exhaust system. If the blower fails or the vent pipe becomes plugged, this switch will sense that there is no air flow through the exhaust vent and will stop the auger from feeding pellets and then finally shutting the stove OFF.

Major Components of our Pellet Stoves:

1. Hopper
2. Auger
3. Combustion Air
4. Combustion Blower
5. Exchanger Tubes
6. Exhaust Blower
7. Burn Pot
8. Ash Pan

GLOSSARY

Burn Pot And Burn Pot Liner: This is where the pellets are dropped from the hopper and then burned.

Blower Mechanism: Device used either to remove exhaust gases from the stove or move air over the heat exchanger and into the room

Clearance To Combustibles: The distance required to maintain a safe operating distance to a combustible material.

Clinkers: Creosote builds up from a higher water content pellet or insufficient fresh air supply.

Combustion Chamber: An area in the stove where the fire is or where combustion of the fuel takes place.

Continuity Test: By using a multimeter set the instrument on Ohms, this is determine if the circuit is complete, or continuous.

Creosote: Black tar like build up produced by high water content pellets or incomplete combustion.

Efficient Flame: Is it a short or brisk forced flame with no black tips or lazy appearance.

Exhaust System: Designed to remove products of combustion from the house in a safe and proper fashion.

Fresh Air Intake: This is a supply of fresh air pulled into the appliance to help combustion of the fire. (Fresh air can also be pulled in from a vented crawl space)

Magnehelic Pressure Gauge: This is an extremely sensitive measuring device that measures vacuum in the stove. (this measurement is in inches of water column. (Example: .01" W.C.)

Multimeter: An instrument used to measure Voltage (VAC VDC), Resistance (OHMS)

Pellet Vent: Is a listed component vent made of stainless steel inside and either a stainless steel or galvanized outer pipe. Can also be a stainless flexible vent for fireplace insert applications.

Pelletized Wood Fuel: Recycled sawdust from sawmills or furniture manufactures. The fuel is compressed and squeezed through an extrusion, all aspects of the fuel are considered. (Example ash content, water content, fines etc.)

Pyroceramic: Is a type of glass used on the stove, this glass is rated for a very high temperature. Temperature rating on this glass is 1400°F.

Rating Plate: A plate in or on the appliance, which shows all certifications as well as the Serial number and Model number of the stove.

Rich Burn: Lazy orange black tipping flames resulting in soot build up as well as the production of carbon monoxide.

Slider Damper: Is a device used to adjust the amount of air to the fire to achieve an efficient flame in the stove.

WARRANTY

Sherwood Industries Ltd. is the manufacturer of the Enviro line of heating products. At Sherwood Industries, our commitment to the highest level of quality and customer service is the most important thing we do. Each Enviro stove is built on a tradition of using only the finest materials and is backed by our Exclusive Lifetime Limited Warranty to the original purchaser. With Enviro, you're not just buying a stove, you're buying a company with years of unequalled performance and quality.

Limited Lifetime Warranty:

Under this warranty, Sherwood Industries Ltd. covers the fireplace or stove body and accessories against defects in materials and workmanship, for part repair or replacement for the first seven (7) years and limited labour for the first two (2) years to the original purchaser. This Warranty covers: Firebox, Heat Exchanger, Burn Pot, Ceramic Glass, Pedestals, Panels, Legs, Log Sets and Door Assembly. Please see the exclusions and limitation section below as certain restrictions and exclusions apply to this warranty.

Limited Three (3) Year Warranty

Under this warranty, Sherwood Industries Ltd. covers the Burn Pot Liner against defects in materials and workmanship, for part repair or replacement for the first three (3) years and limited labour for the first two (2) years to the original purchaser. Please see the exclusions and limitation section below as certain restrictions and exclusions apply to this warranty.

Limited Two (2) Year Warranty:

Under this warranty, Sherwood Industries Ltd. covers: Ignitor, Auger Motor, Circuit Board, Timers, Temp Sensors, Blowers, Vacuum Switch, Firebox Panels, and Wire Harness, against defects in materials and workmanship, for part repair or replacement for the first two (2) years and limited labour for the first two (2) years to the original purchaser. Please see the exclusions and limitation section below as certain restrictions and exclusions apply to this warranty.

Limited One (1) Year Warranty:

Under this warranty, Sherwood Industries Ltd. covers all exterior surface finishes against defects in materials and workmanship, for part repair or replacement and limited labour for the first (1) year to the original purchaser. Please see the exclusions and limitation section below as certain restrictions and exclusions apply to this warranty.

Here is how our Warranty works

If you have any concerns with your Enviro product please contact the dealer where you purchased the fireplace or stove. Your dealer shall make all claims under this warranty in writing.

To the Dealer

When filling out a warranty claim please complete the following information on an official warranty claim form:

Customer information: Name, address and telephone number of purchaser and date of purchase.

Dealer information: Date of installation, name of installer and dealer, serial number of the appliance, nature of complaint, defects or malfunction, description and part numbers of any parts replaced.

To the Distributor

Sign and verify that work and information are correct.

WARRANTY

Exclusions and Limitations:

1. This Warranty does not cover tarnish, discoloration or wear on the plating or paint.
2. This Warranty excludes wear and tear or breakage caused by cleaning, moving or service on log set.
3. A qualified installer must install this stove or fireplace. This Limited Warranty covers defects in materials and workmanship only if the product has been installed in accordance with local building and fire codes; in their absence, refer to the owner's manual. If the product is damaged or broken as a result of any alteration, willful abuse, mishandling, accident, neglect, or misuse of the product, the Limited Warranty does not apply.
4. The stove must be operated and maintained at all times in accordance with the instructions in the Owner's Manual. If the unit shows signs of neglect or misuse, it is not covered under the terms of this Warranty policy. Performance problems due to operator error will not be covered by the Limited Warranty policy.
5. As this is a heating appliance some changes in colour of surface finishes may occur. This is not a flaw and as such is not covered under this warranty.
6. Some minor expansion, contraction, or movement of certain parts and resulting noise, is normal and not a defect and, therefore, is not covered under this Limited Warranty.
7. Misuse includes over-firing. Over-firing this appliance can cause serious damage and will nullify the Limited Warranty.
8. The Limited Warranty will cover glass thermal breakage only and will not cover misuse of the stove glass, including but not limited to glass that is struck, has surface contaminates or has had harsh or abrasive cleaners used on it.
9. This warranty does not cover products made or provided by other manufacturers and used in conjunction with the operation of this stove without prior authorization from Sherwood Industries Ltd. The use of such products may nullify the Limited Warranty on this stove. If unsure as to the extent of this Limited Warranty, contact your authorized Enviro dealer before installation.
10. Sherwood Industries Ltd. will not be responsible for inadequate performance caused by environmental conditions.
11. The Limited Warranty does not cover installation and operational related problems such as spillage caused by environmental conditions. Environmental conditions include but are not limited to nearby trees, buildings, roof tops, wind, hills, mountains, inadequate venting or ventilation, excessive offsets, negative air pressures or other influences caused by mechanical systems such as furnaces, fans, clothes dryers etc.
12. The Limited Warranty is void if:
 - a) The stove has been operated in atmospheres contaminated by chlorine, fluorine or other damaging chemicals.
 - b) The stove is subject to submersion in water or prolonged periods of dampness or condensation.
 - c) Any damage to the unit, combustion chamber or other components due to water, or weather damage which is the result of, but not limited to, improper chimney/venting installation.
 - c) Salt air in coastal areas or high humidity can be corrosive to the finish; these environments can cause rusting. Damage caused by salt air or high humidity is not covered by the Limited Warranty.
13. Exclusions to the Limited Warranty include: injury, loss of use, damage, failure to function due to accident, negligence, misuse, improper installation, alteration or adjustment of the manufacturer's settings of components, lack of proper and regular maintenance, alteration, or act of God.
14. The Limited Warranty does not cover damage caused to the fireplace or stove while in transit. If this occurs, do not operate the stove and contact your courier and/or dealer.
15. The Limited Warranty does not extend to or include firebox paint, door or glass gaskets with damage caused by normal wear and tear, or exterior paint discoloration or chipping, worn gaskets, etc.
16. The Limited Warranty does not include damage to the unit caused by abuse, improper installation, or modification of the unit.

WARRANTY

17. Damage to plated surfaces caused by fingerprints, scratches, melted items, or other external scores and residues left on the plated surfaces from the use of abrasive cleaners or polishes is not covered in this warranty.
18. The Limited Warranty does not cover tarnish, discoloration or wear on the plated surfaces.
19. The paint on the Metal Brick Liner may peel. This is due to the extreme conditions applied to the paint during normal usage. It is not a flaw and is not covered under warranty.
20. Sherwood Industries Ltd. is free of liability for any damages caused by the fireplace or stove, as well as inconvenience expenses and materials. The Limited Warranty does not cover incidental or consequential damages.
21. The Limited Warranty does not cover any loss or damage incurred by the use or removal of any component or apparatus to or from the Enviro fireplace or stove without the express written permission of Sherwood Industries Ltd. and bearing a Sherwood Industries Ltd. label of approval.
22. Any statement or representation of Enviro products and their performance contained in Enviro advertising, packaging literature, or printed material is not part of the Limited Warranty.
23. The Limited Warranty is automatically voided if the fireplace or stove's serial number has been removed or altered in any way. If the stove is used for commercial purposes, it is excluded from the Limited Warranty.
24. No dealer, distributor, or similar person has the authority to represent or warrant Enviro products beyond the terms contained within the Limited Warranty. Sherwood Industries Ltd. assumes no liability for such warranties or representations.
25. Sherwood Industries Ltd. will not cover the cost of the removal or re-installation of the stove, hearth, facing, mantels, venting or other components.
26. Labour to replace or repair items under this Limited Warranty will be covered per our warranty service fee reimbursement schedule. Labour rates are set per component and as such total labour costs may not be covered.
27. Sherwood Industries Ltd. is not liable for freight or labour on any stove replaced in-field and is not liable for travel costs for service work. In the event of in-home repair work, the customer will pay any in-home travel fees or service charges required by the Authorized Dealer.
28. At no time will Sherwood Industries Ltd. be liable for any consequential damages which exceed the purchase price of the unit. Sherwood Industries Ltd. has no obligation to enhance or modify any stove once manufactured (example: as a stove evolves, field modifications or upgrades will not be performed).
29. This Limited Warranty is applicable only to the original purchaser and it is non-transferable.
30. This warranty only covers Enviro products that are purchased through an authorized Enviro dealer.
31. If for any reason any section of the Limited Warranty is declared invalid, the balance of the warranty remains in effect and all other clauses shall remain in effect.
32. The Limited Warranty is the only warranty supplied by Sherwood Industries Ltd., the manufacturer of the stove. All other warranties, whether express or implied, are hereby expressly disclaimed and purchaser's recourse is expressly limited to the Limited Warranty.
33. Sherwood Industries Ltd. and its employees or representatives will not assume any damages, either directly or indirectly, caused by improper usage, operation, installation, servicing or maintenance of this stove.
34. Sherwood Industries Ltd. reserves the right to make changes without notice. Please complete and mail the warranty registration card and have the installer fill in the installation data sheet in the back of the manual for warranty and future reference.
35. Sherwood Industries Ltd. is responsible for stocking parts for a maximum of seven (7) years after discontinuing the manufacture or incorporation of the item into its products. An exception to this would be if an OEM supplier is not able to supply a part.

SHERWOOD INDUSTRIES LTD.
6782 OLDFIELD RD. SAANICHTON, BC, CANADA V8M 2A3
September 8, 2009
C-12027