

Installation & Operations Manual

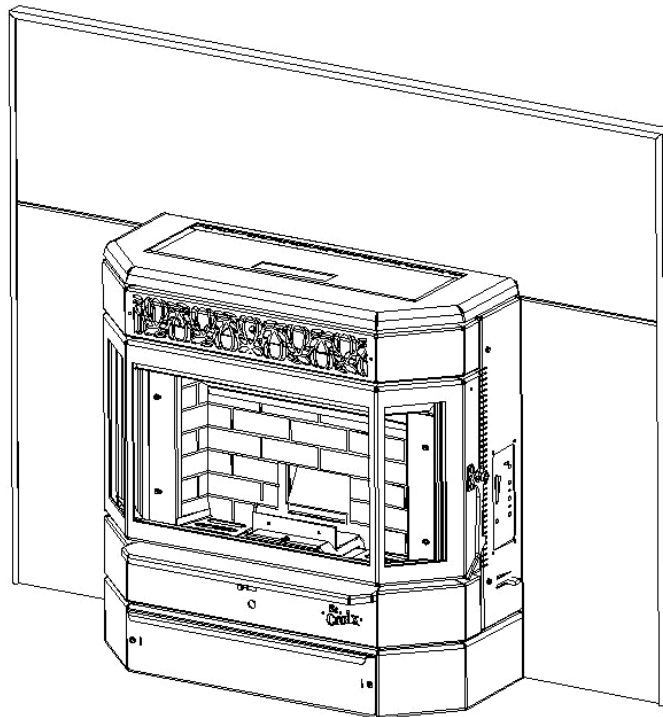

Ashby-P Insert



"Please read this entire manual before installation and use of this pellet fuel-burning room heater. Failure to follow these instructions could result in property damage, bodily injury or even death."

"Contact local building or fire officials about restrictions and installation inspection requirements in your area."

Save these Instructions
1113

Ashby-P Insert

TABLE OF CONTENTS

General Information	4
Installation Check List	5
Ashby-P Layout Diagram	6-7
Ashby-P Dimensions, Location & Clearances	8-9
Approved Installations	10
Installing as a Zero-Clearance Unit	11
Surround Instructions.....	12
Exhaust Venting.....	14
Venting - Approved Materials	14
Venting-Typical PL Vent Components.....	15
Venting - Determining Materials	16
Venting - Termination Requirements.....	17-18
Venting: Termination Clearance Requirements	19
Venting – Into an existing Chimney.....	20-22
Combustion Air	23
Mobile Home Installation	24
Thermostat Hook-Up	25
Ashby Operation	26
Installation Check	26
Preventing Chimney Fires.....	26
Ashby-P Approved Fuels	27
Ashby-P Ashpan Locations.....	28
Control Board Features	30-31

Pre-Lighting & Lighting instructions.....	32-33
Shutting Off the Insert	34
Diagnostic & Safety Features	35-36
Combustion Air Damper – Location and Adjustments.....	37-38
Thermostat Control & Pilot Settings.....	38
Ashby-P Maintenance.....	39
Versa Grate System.....	39-40
Daily Maintenance (Versa Grate System)	40-42
Periodic Maintenance.....	42-45
Yearly Maintenance	45-46
Safe Operation	46
Wiring Schematic.....	47
Troubleshooting & Frequently Asked Questions	48-51
Ashby-P Parts Breakdown	52-54
Warranty	55
Ashby-P Info & Notes	56

Even Temp, Inc.
P.O. Box 127
Waco, NE 68460

EMAIL: support@stcroixstoves.com

WEB ADDRESS: www.stcroixstoves.com

Save This Installation & Operations Manual

GENERAL INFORMATION SAFETY PRECAUTIONS

SAFETY NOTICE: The Ashby-P must be properly installed in order to prevent the possibility of a house fire! These installation instructions must be strictly observed! The Maintenance schedule must be followed as described in this manual. Failure to follow instructions may result in property damage, bodily injury or even death.

The Ashby-P's exhaust system works with negative combustion chamber pressure and a slightly positive chimney pressure. Therefore, it is imperative that the air intake and exhaust system be airtight and installed correctly. Do not install a flue damper in the exhaust vent of this unit.

Do not connect this unit to a chimney flue serving another appliance.

BUILDING PERMIT

CONTACT THE LOCAL BUILDING OFFICIALS TO OBTAIN A PERMIT AND INFORMATION ON ANY LOCAL INSTALLATION RESTRICTIONS AND INSPECTION REQUIREMENTS.

DEFINITION OF "MULTI-FUEL INSERT"

The word "Multi-Fuel Insert" as used in this manual to describe the Ashby-P is interpreted to mean an Insert that is approved to burn wood pellets, Cherry Pits or a 50/50 percent Mixture of Wood pellets and Corn. This model is not intended as the sole source of heat. ***The Ashby-P is approved for the above mentioned fuels only.***

SAFETY TESTING

The Ashby-P has been independently tested and listed by Warnock Hersey Laboratories in accordance with the proposed ASTM E 1509-2004 Standards and the applicable portions of UL 1482 and ULC S627/B366.2, and Oregon Administrative Rules 814-23-901 through 814-23-909, stating requirements for installation the Ashby and for mobile home installations. The safety-listing label is located on the top of the hopper. Please refer to label for pertinent information.

DISCLAIMER OF WARRANTY

Since Even Temp Company has no control over the installation of the Ashby-P, Even Temp Company grants no warranty, implied or stated, for the installation of the Ashby and assumes no responsibility for any special, incidental or consequential damages.

MANUFACTURED BY:

Even Temp Inc
Hwy 34
Waco, NE, 68467

Ashby-P Insert

BEFORE INSTALLATION THOROUGHLY READ AND UNDERSTAND THIS MANUAL

SAFETY NOTICE

PLEASE READ THE ENTIRE MANUAL BEFORE INSTALLING AND USING YOUR NEW MULTI-FUEL INSERT. FAILURE TO FOLLOW INSTRUCTIONS MAY RESULT IN PROPERTY DAMAGE, BODILY INJURY, OR EVEN DEATH.

INSTALLATION CHECK LIST

FOR USE IN THE U.S. AND CANADA

MOBILE HOME APPROVED

CHECK WITH LOCAL AUTHORITIES AND OBTAIN NEEDED PERMITS

WE RECOMMEND INSTALLATION BY A QUALIFIED PROFESSIONAL.

BEFORE STARTING THE MULTI-FUEL INSERT FOR THE FIRST TIME

1. Under certain conditions outside combustion air is recommended. Use only approved parts. When using outside air for combustion, check that the outside air inlet is connected to draw fresh air from outside the building.
2. All joints of PL vent and single wall stainless steel pipe should be fastened by at least 3 screws and correctly installed. (Follow vent manufacturer's instructions). Seal all joints with high temperature silicone to create an airtight seal.
3. **WARNING:** The high temperature paint on this Multi-Fuel Insert may take several hours of burning at a high fuel setting to cure fully. During this time, an odor that is not harmful may be evident. When odors are present, the area around the Multi-Fuel Insert should be well ventilated.
4. **Caution:** The high temperature paint can be easily scratched prior to burning the Multi-Fuel Insert.

CAUTION

FAILURE TO FOLLOW THE INSTRUCTIONS IN THE INSTALLATIONS MANUAL MAY RESULT IN A HOUSE FIRE. PLEASE FOLLOW INSTALLATION AND MAINTENANCE INSTRUCTIONS.

Ashby-P

Stove Layout

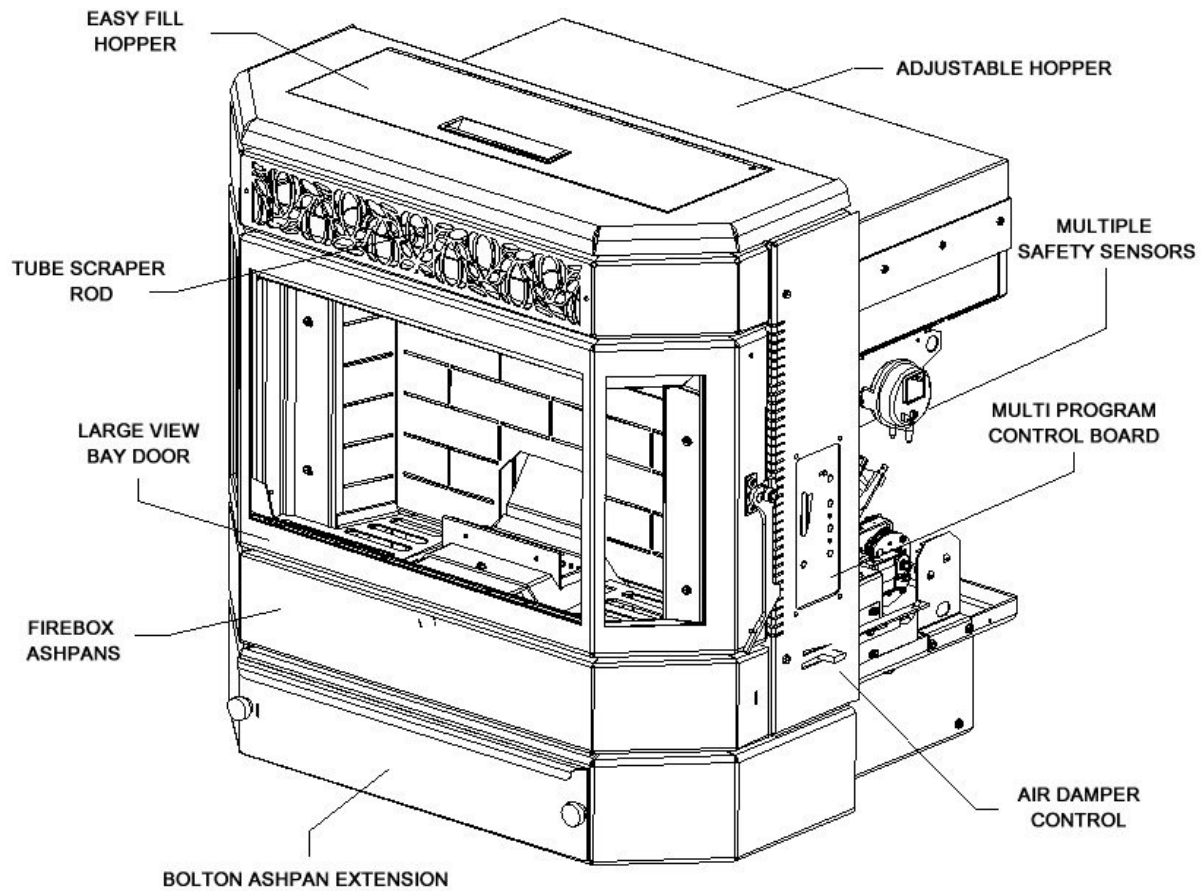

Figure 1

There are two burn systems used in the Ashby. These systems are interchangeable in the stove body. This side of the Manual covers the **ASHBY-P**, which uses the **Versa Grate System**

The “**Versa Grate System**”. Is a Fully Automatic System that offers Self-Ignition. This system is approved for Pellets & Cherry Pits and a mixture of 50%-50% Pellets and Corn. *See Figure 2 on the next page.*

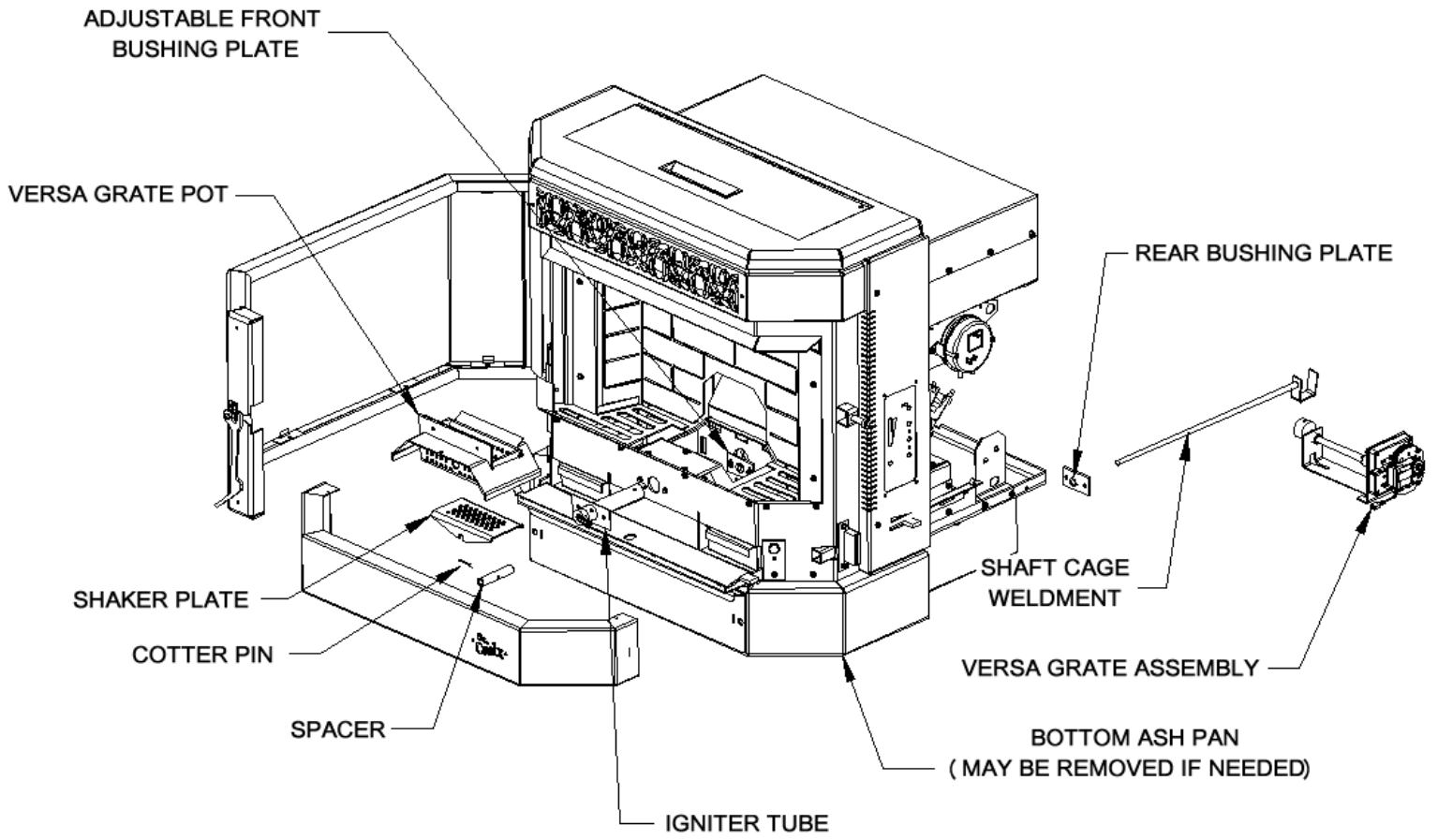

Figure 2

Versa Grate System Approved with the Following Fuels:

Pellets, Cherry Pits and a 50/50 percent Mixture of Pellets and Corn

ASHBY-P DIMENSIONS

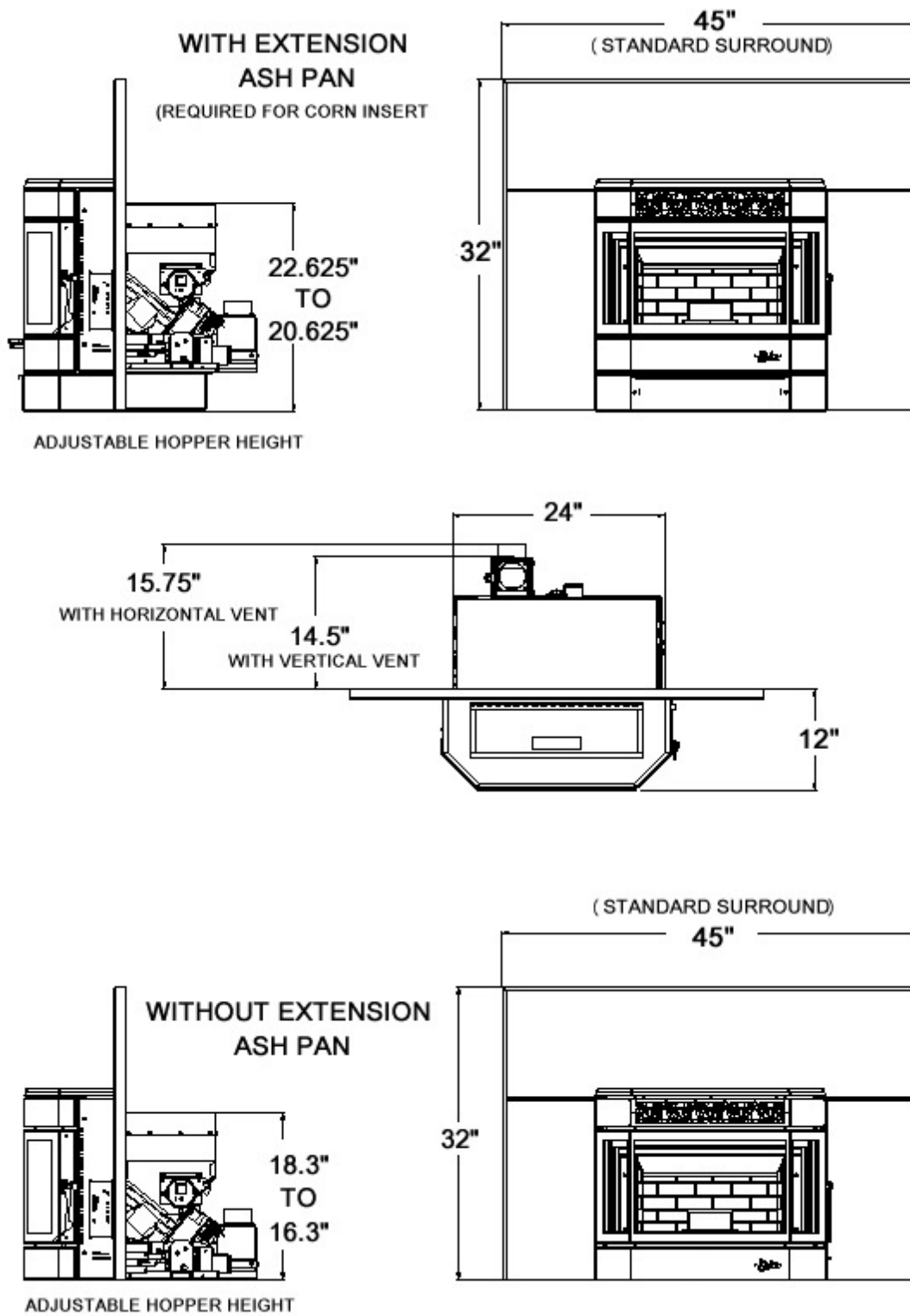

Figure 3

Clearance to Combustibles

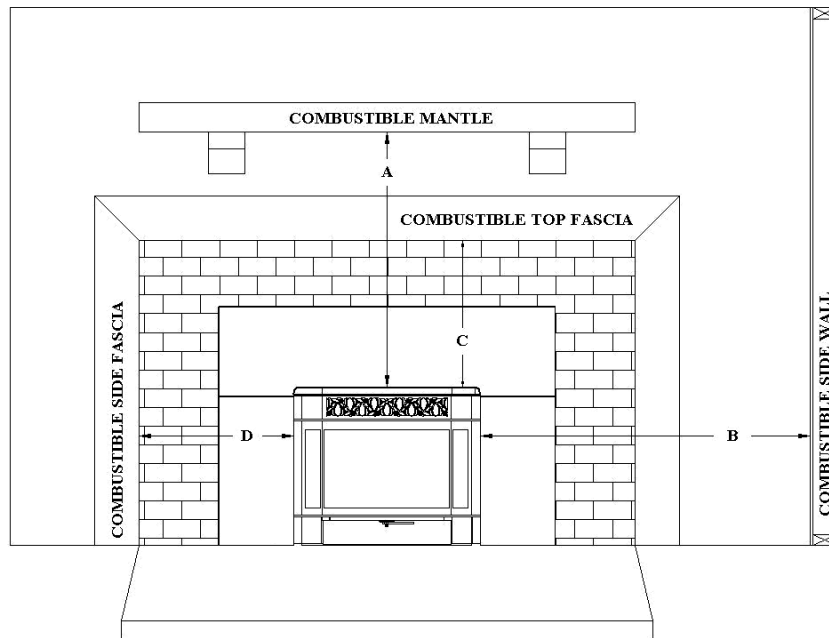

Figure 4

- A - Top of Insert to Combustible Mantle 12"
- B - Side of Insert to Combustible Wall 10"
- C - Top of Unit to Combustible Top Fascia.....Does not apply
- D - Side of Unit to Combustible Top Fascia.....Does not apply

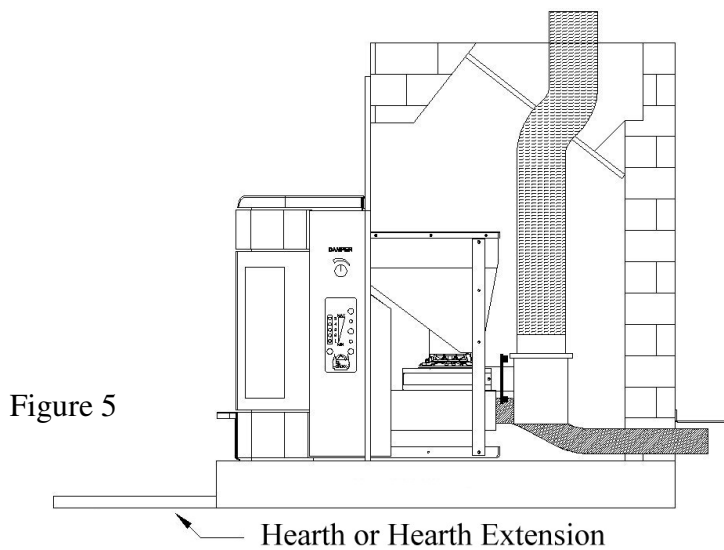

Figure 5

The Hearth must extend a minimum of 6" (152 mm) in Front of Unit and beyond each side of the Fuel Loading and Ash Removal Opening(s). If the hearth is too short a non-combustible Hearth Extension must be installed.

Approved installations

1. In a Masonry Fireplace – The Masonry Fireplace must be built according to the requirements of the **Standards of Chimneys, Fireplaces, Vents and Solid Fuel Burning appliances, N.F.P.A. 211** and any National, State or Local codes that apply.
2. In a Zero Clearance Fireplace – The Factory built Zero-Clearance Fireplace and its Chimney must be listed per UL 127 or ULC S610 standards.
3. As a Zero Clearance Fireplace. **When building the unit in as a Zero-Clearance Fireplace, St. Croix factory Built Cabinet, part # 80P53963, must be used.** Follow instructions on page 11.

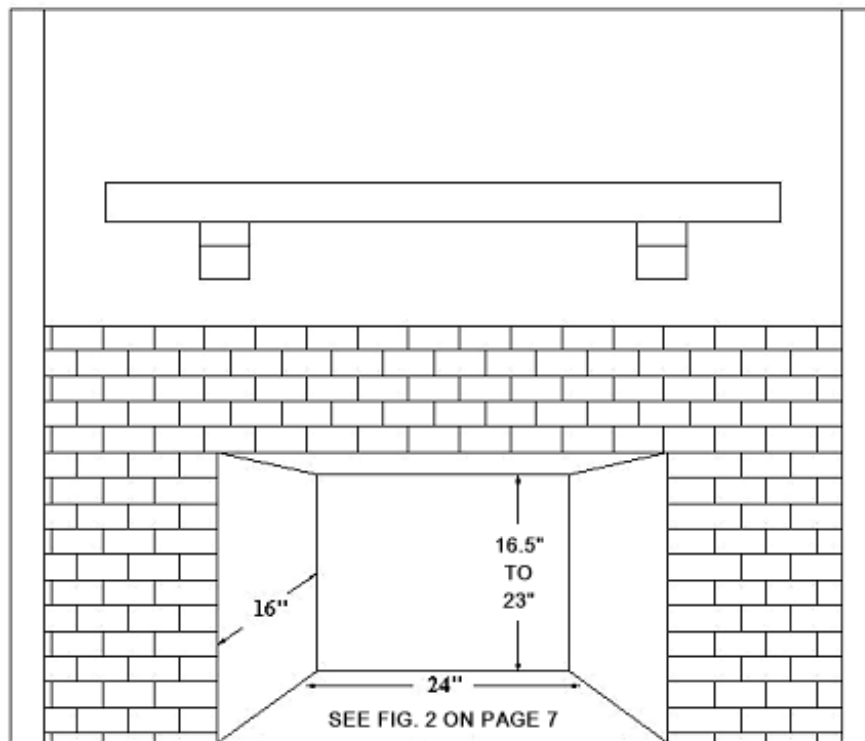

Figure 6

Minimum Fireplace Opening

Installing as a Zero-Clearance unit

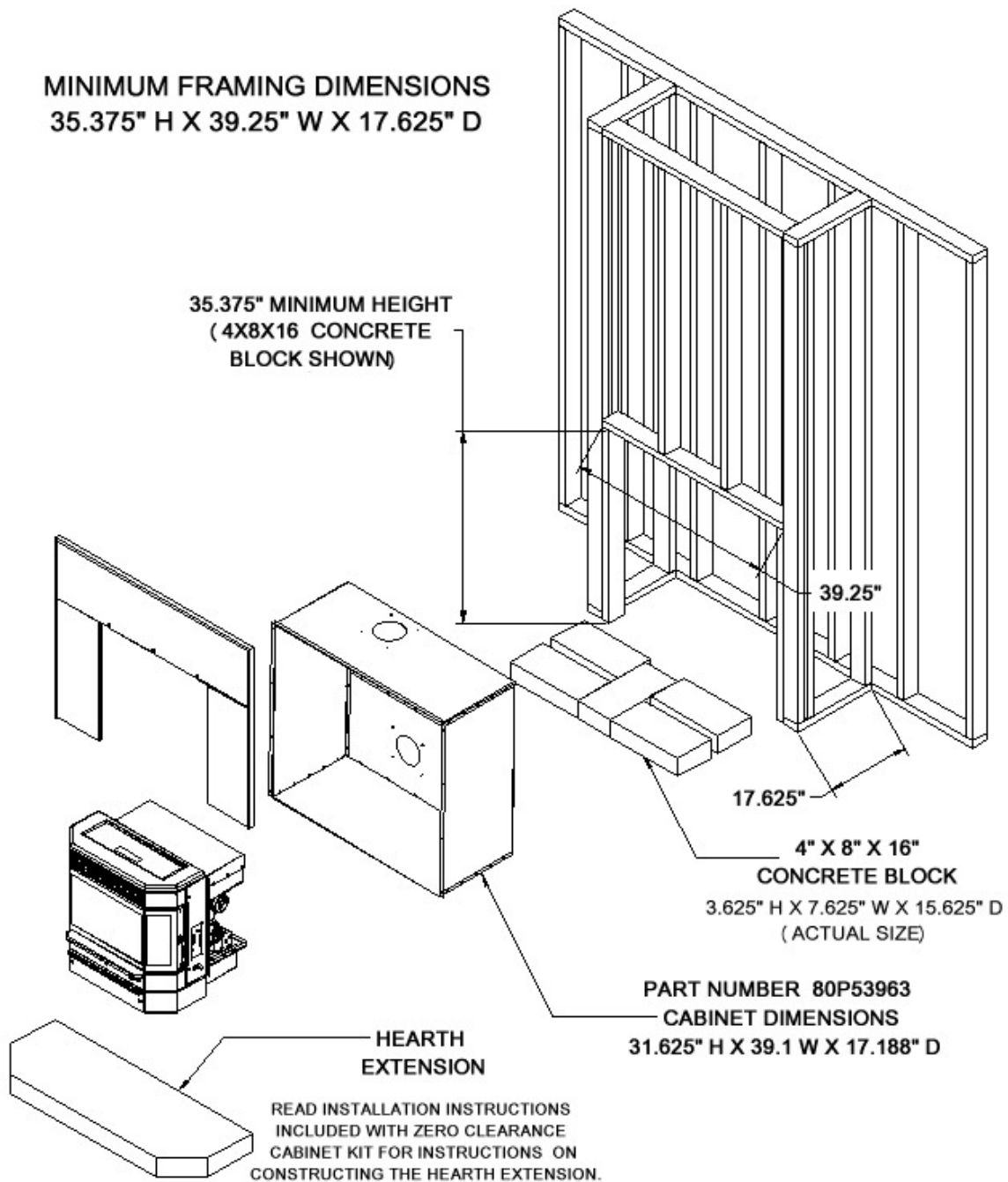

Figure 7

When installing the insert as a Zero-Clearance unit, it must be installed into the St. Croix metal cabinet part number 80P53963. The cabinet must be installed on five 4x8x16 concrete blocks as shown in figure 7 above. The framing dimensions listed above are based on using 4x8x16 block. If raising the unit up higher, factor the difference in height into the dimensions.

The cabinet allows for top and rear venting

Surround Instructions

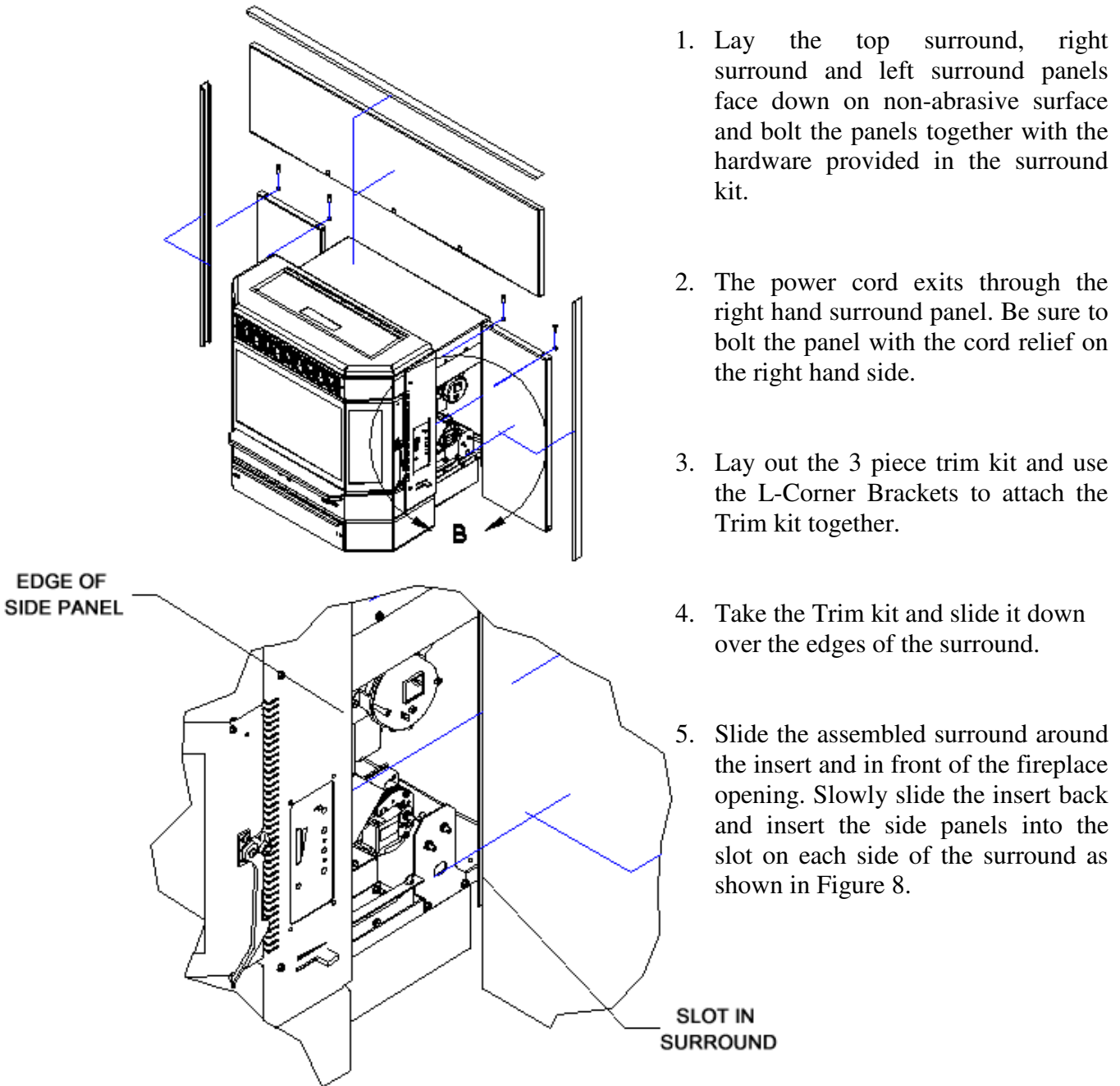

Figure 8

Caution

INSTALLATION IS TO BE PERFORMED BY A QUALIFIED INSTALLER OR DEALER.

ADHERE TO ALL CLEARANCES SPECIFIED BY THE MANUFACTURER OF THE VENTING SYSTEM USED.

ADHERE TO ALL CLEARANCES SPECIFIED IN THE INSTALLATION INSTRUCTIONS OF THE ASHBY-P INSERT.

THE ASHBY-P INSERT USES A POSITIVE PRESSURE VENT SYSTEM. DO NOT INSTALL A FLUE DAMPER IN THE EXHAUST SYSTEM OF UNIT

DO NOT CONNECT THE ASHBY-P INSERT TO A CHIMNEY SYSTEM THAT IS CONNECTED TO ANOTHER APPLIANCE.

DO NOT INSTALL THIS UNIT IN A SLEEPING ROOM

ATTENTION

CONDENSATION: When planning the installation of your Ashby-P Insert, keep in mind that condensation is detrimental to exhaust systems. Corn has a higher moisture content than pellets and can be more susceptible to condensation forming in certain types of installations. Install the Ashby with a minimum of the Vent system exposed to the cold temperatures outside the envelope of the house. Insulate the vent system if in doubt. Check with the manufacturer of your venting system that they honor the warranty of their PL Vent with the use of corn.

ATTENTION

BATTERY BACKUP: We strongly recommend using a battery backup system if the Ashby is installed using horizontal venting only. This prevents any smoke from entering your home in the event of a power failure. The battery back-up system must provide “pure sine wave” power to operate the unit.

VENTING: APPROVED MATERIALS

The Ashby requires a venting system approved for pellet or corn venting by a certified testing lab. Approved pellet or corn venting materials are: 1) PL vent, a double wall vent with a stainless steel liner; and 2) Single wall rigid or flexible stainless steel pipe. PL Vent and Single wall vent is available through manufacturers such as: Energy Vent LTD, James A. Ryder, Simpson DuraVent and Selkirk Metalbestos and is carried by many local dealers. In this manual approved venting will be referred to a “PL vent” or “Single wall vent”. All single wall vent adaptors must be stainless steel.

NOTE: TYPE “B” GAS VENT MUST NOT BE USED IN THE INSTALLATION OF THE ASHBY-P INSERT

Examples of venting system components follow:



High temperature ceramic roping reduces potential fly ash escaping through joints.

Stainless steel inner liners resist corrosive flue gas damage to the system.



Flex pipe should be stainless steel, 4 ply construction with a total thickness of approximately .07 inches.

TYPICAL PL VENT COMPONENTS



*RAIN CAP
VERTICAL OR
HORIZONTAL*



WALL THIMBLE



*CHIMNEY
ADAPTER*



SUPPORT BRACKET



*ADJUSTABLE LENGTH
PIPE
w/TEE CAP*



*SINGLE TEE
w/TEE CAP*



*SINGLE REDUCTION
TEE w/TEE CAP*



*DOUBLE TEE
w/TEE CAP*



PIPE ADAPTER



INCREASER



45° ELBOW



90° ELBOW

VENTING: DETERMINING MATERIALS

TYPE OF MATERIALS:

1. *PL Vent / Corn Vent must be used.*

2. All Joints in the venting installation must be fastened together using three screws. All joints of the venting system must be sealed with High Temp Silicone to make a gas tight fit.

3. **Exception: Single wall stainless steel may be used inside an existing chimney.** (No clearances to combustibles are needed on single wall stainless steel adaptors, rigid or flex pipe installed within a chimney.)

4. A clean out “tee” has been built into the Ashby. This cleanout system is to assist in periodically cleaning the vent pipe. **The exhaust system can periodically be cleaned from the inside of the unit without having to pull the unit from the fireplace.**

NOTE: ADHERE TO THE PL VENT CLEARANCES TO COMBUSTIBLES AS REQUIRED. STRICTLY OBSERVE THE PL VENT MANUFACTURER’S SAFETY SPECIFICATIONS.

QUANTITY OF MATERIALS:

1. It is recommended that the vent system be installed with a **minimum of three feet (3’) of vertical rise** above the exhaust port on the back of the Ashby.

FAILURE TO PROVIDE THE NATURAL DRAFT THAT RESULTS FROM A VERTICAL RISE MAY RESULT IN SMOKE BEING RELEASED INTO THE HOUSE WHEN ELECTRICITY TO THE UNIT IS INTERRUPTED WHILE BURNING OR SMOLDERING FUEL REMAINS IN THE BURN GRATE. (*See “Battery Backup” on page 9*)

2. It is not recommended to run vertical venting outside the heated environment where the Ashby is installed. Running a venting system in a cold environment may cause the flue temperatures to cool down too much for adequate drafting.

Additional vertical exhaust venting should be provided when using:

a. More than one (1) elbow or tee; and/or

b. Horizontal runs of over three (3) feet. (*Horizontal runs over 10 feet not recommended*)

3. For a venting system ending in a horizontal run, the exhaust pipe must be terminated by a listed end cap or a PL vent elbow (45 or 90 degrees). Note: End caps or elbows must vent exhaust gases away from the building.

4. For termination above the building roofline a rain cap is required.

5. The exhaust pipe on all Ashby’s is 3” O.D. to accommodate a pipe adaptor.

VENTING: TERMINATION REQUIREMENTS

In determining optimum vent termination, carefully evaluate external conditions especially when venting directly through a wall. Since you must deal with odors, gases, and fly ash, consider aesthetics, prevailing winds, distances from air inlets and combustibles, location of adjacent structures and any code requirements.

1. Exhaust must terminate above combustion air inlet elevation.
2. Do not terminate vent in any enclosed or semi-enclosed area, (i.e. Carports, garage, attic crawl space, etc.) or any location that can build up a concentration of fumes.
3. Vent surfaces can get hot enough to cause burns if touched by children. Non-combustible shielding or guards may be required

The type of installation must first be considered before determining the exact location of the venting termination in relation ship to doors, window, cavities or air vents.

- a. **Without** Outside Air connected to the unit. For These types of installations please refer to the dimensions listed below in figure 9.

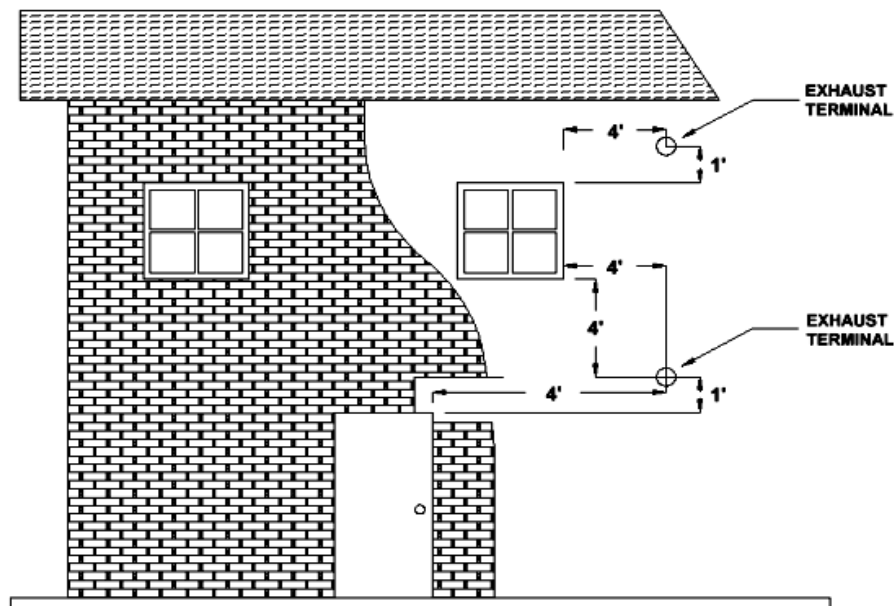

Figure 9

4' (1.2 m) BELOW	a door, window, cavity, or air vent
Or	
4' (1.2 m) HORIZONTALLY FROM	a door, window, cavity, or air vent
Or	
1' (305 mm) ABOVE	a door, window, cavity, or air vent

- b. **With** Outside Air Connected to the unit. In this manner the appliance is a Direct Vent Appliance (sealed Combustion System) as listed in NFPA 211-6.

3.3.3.2 Direct Vent Appliance (Sealed Combustion System Appliance) A system consisting of an appliance, combustion air and flue gas connections between the appliance and the outside atmosphere, and a vent cap supplied by the manufacturer, and constructed so that all the air for combustion is obtained from the outside atmosphere and all flue gases are discharged to the outside atmosphere.

Special Venting Arrangements are listed in NFPA 211-31

10.7.1.2 The Vent Terminal of a Direct Vent Appliance with an input of 10000 BTU/Hr or less shall be located at least 6" from any opening into a building, and such an appliance with an input of over 10000 BTU/Hr, but not over 50000 BTU/Hr shall not be located less than 9" from any opening through which vent gases could enter a building, and the vent terminal of such appliance with an input over 50000 BTU/Hr shall be located not less than 12" from the opening.

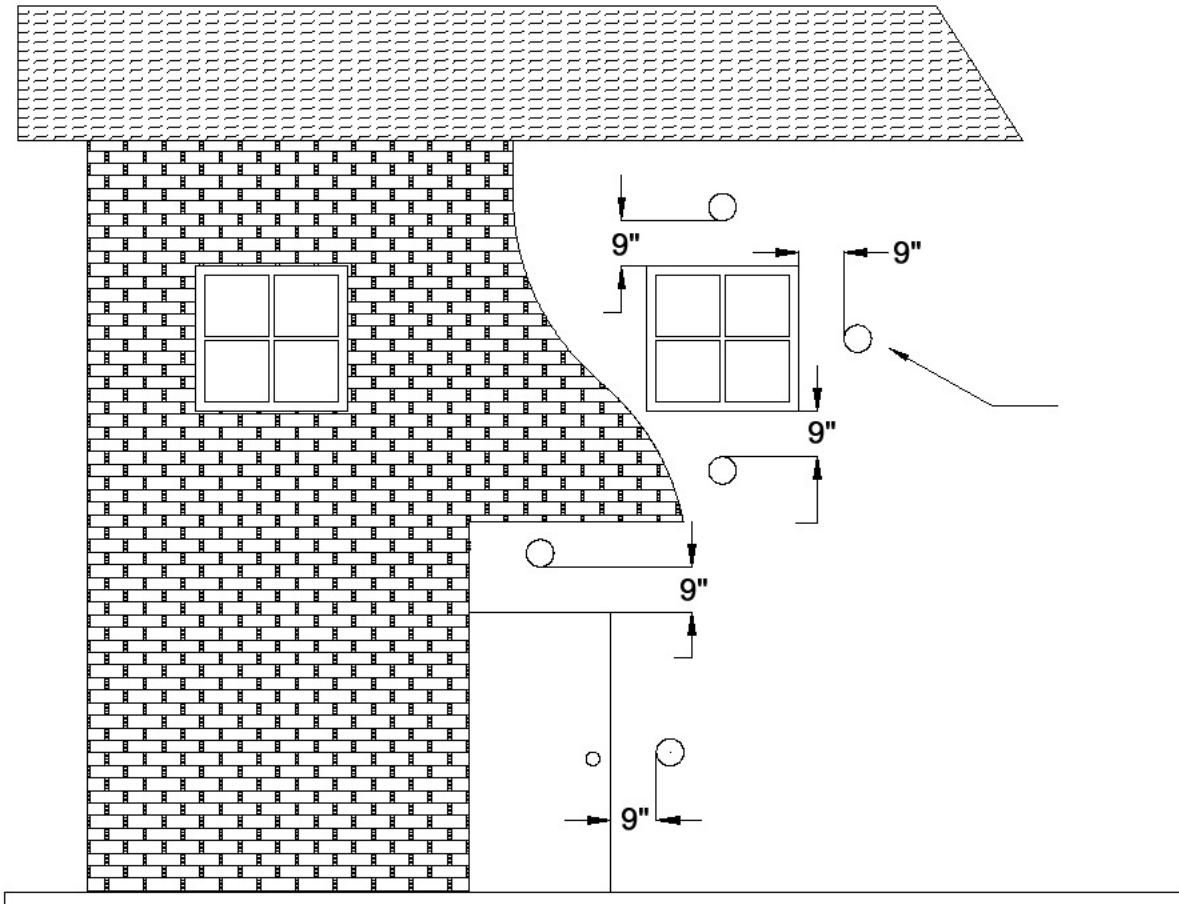

Figure 10

9" (229 mm) ABOVE, BELOW OR HORIZONTALLY FROM a door, window, cavity, or air vent.

VENTING: TERMINATION CLEARANCE REQUIREMENTS

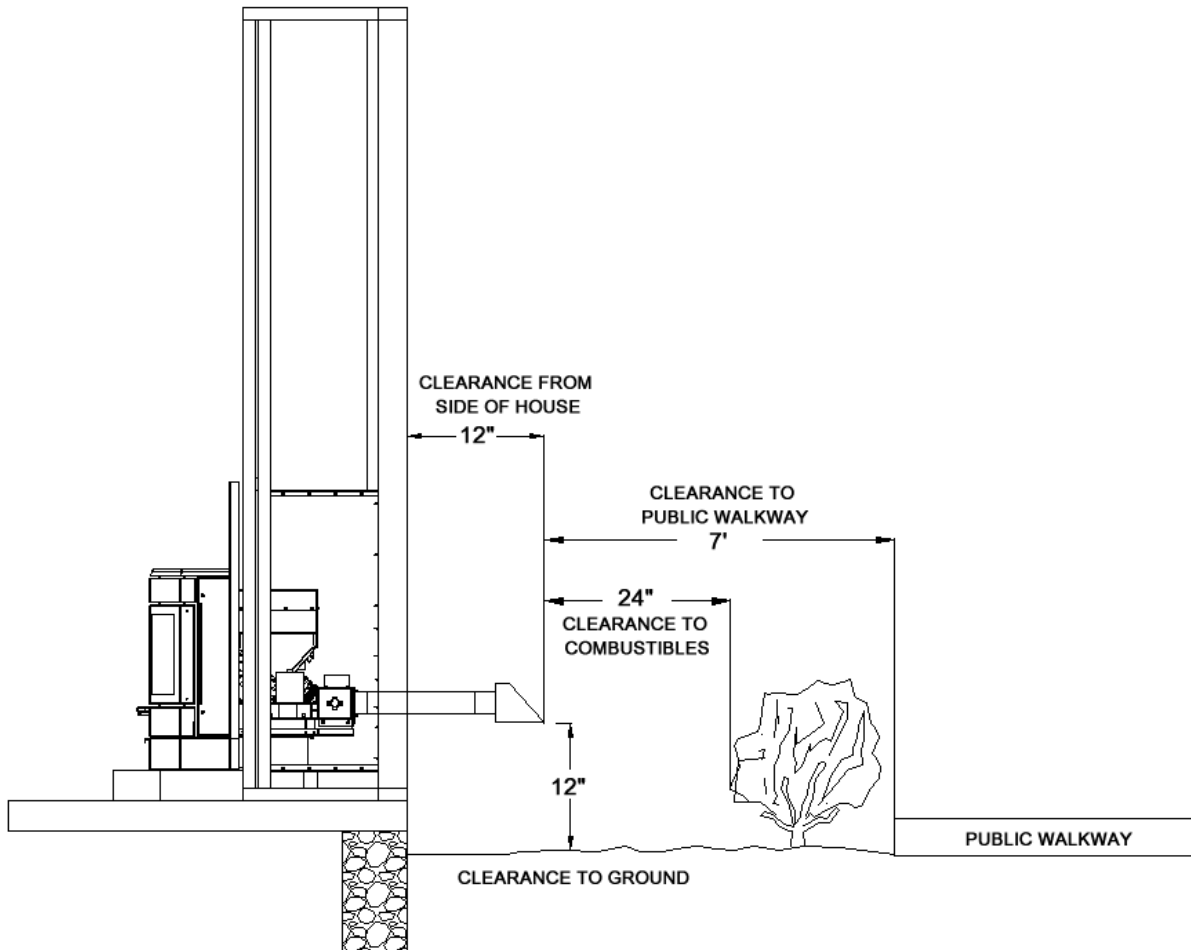

Figure 11

THE EXHAUST TERMINATION LOCATION MUST BE AT LEAST

1' (305 mm)	ABOVE the ground level
7' (2.1 m)	FROM a public walkway
1' (305 mm)	FROM The wall penetration point
3' (915mm)	FROM a gas meter/regulator assembly
2' (610 mm)	FROM any adjacent combustibles such as: Adjacent buildings, fences, protruding parts of the structure, roof eaves or overhangs, plants, shrubs, etc.

Installation

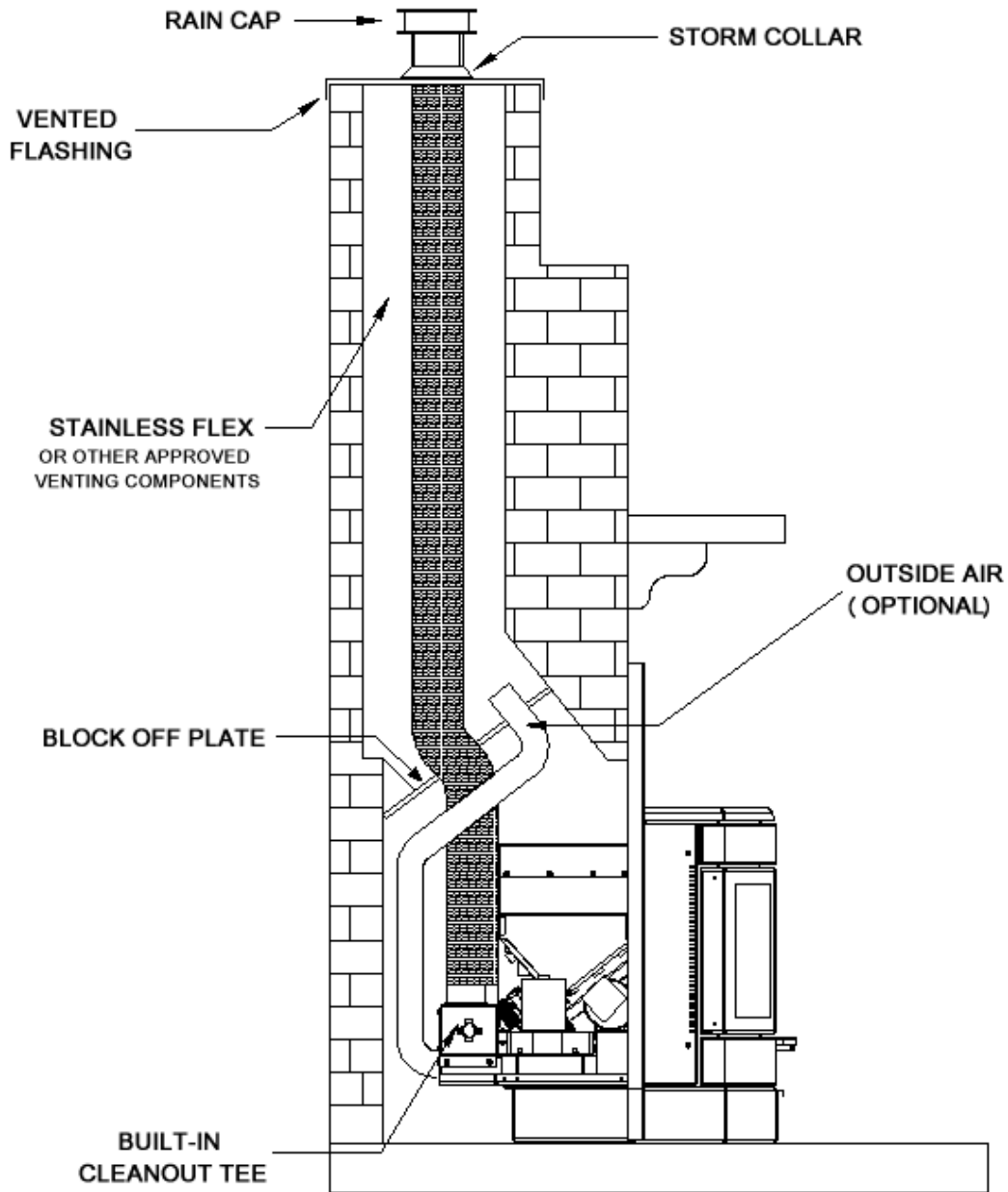

Figure 12

Full reline using existing Chimney as the source for Outside Air (Outside Air is Optional). Outside combustion air may be recommended when certain conditions exist (i.e. negative pressure). A chimney system with known drafting problems may require a liner, which may also need to be insulated to keep vent system warm in cold chimney environment.

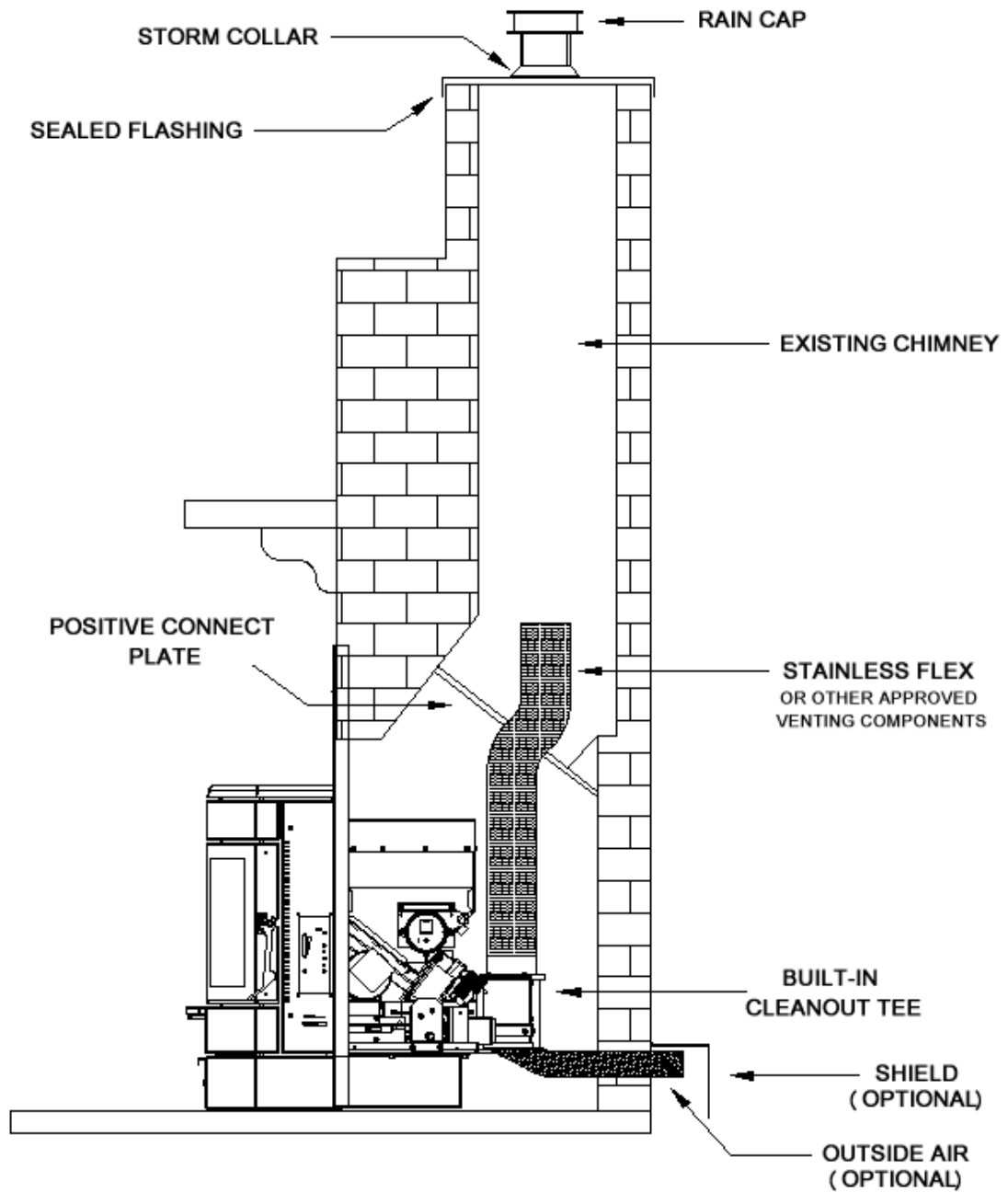

Figure 13

Positive Connection to an existing Chimney with outside air (optional). The stove may be connected to an existing Class A chimney or a masonry chimney which meets the minimum requirements of NFPA 211.

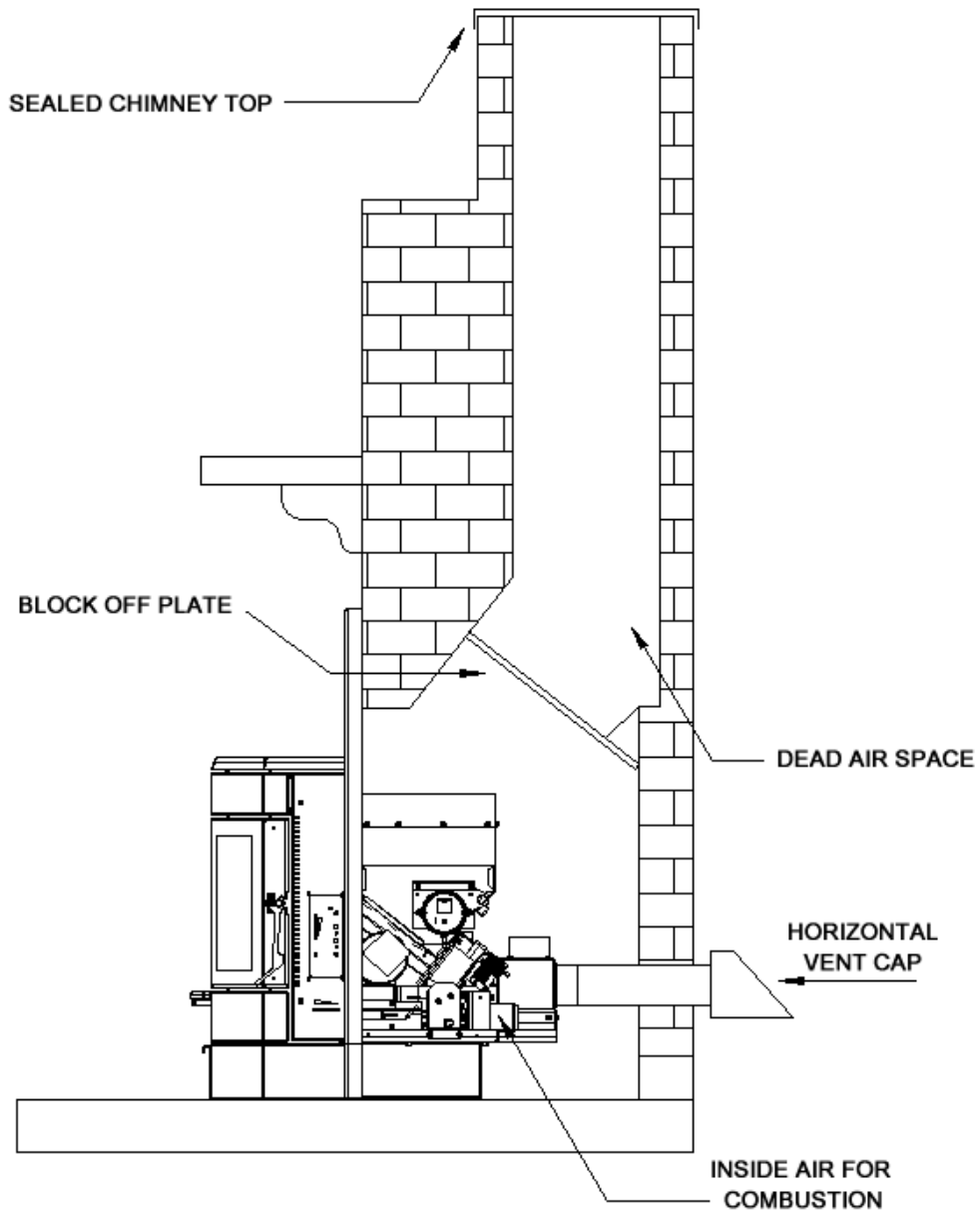

Figure 14

Direct Connect using 3" PL Vent using Inside Air for Combustion
 (Masonry Fireplaces or as a built-in Zero-Clearance unit only)

ATTENTION: We strongly recommend using a battery backup system if the stove is installed using horizontal venting only. This prevents any smoke from entering your home in the event of a power failure.

COMBUSTION AIR

1. Under certain conditions it is recommended that the Ashby be connected to an outside source of combustion air to improve performance. Flexible metal hose, or rigid metal pipe, (conduit), must be connected around (NOT INSIDE) the combustion air inlet tube. Be careful not to pinch or bend the outside air pipe with too small a radius which may be terminated flush with the outside wall but should be protected from wind and weather by a hood. Note: The outside air pipe must terminate above the maximum snow line.

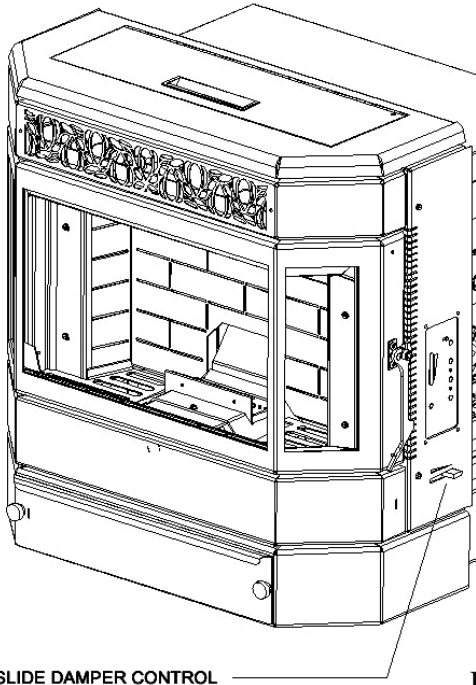

Figure 15

WARNING

USE THE AIR INTAKE DAMPER FOR ADJUSTING COMBUSTION INLET AIR ONLY! OTHER METHODS OF RESTRICTING OR BLOCKING COMBUSTION INLET AIR ARE STRICTLY PROHIBITED!

2. Outside air may be drawn from a semi-enclosed attic or crawl space or any semi-enclosed space. Take care not to draw cold air past water pipes that may freeze.
 3. Increase the outside air pipe diameter to 3" for runs over ten (10) feet and elevation over 4,000 feet. Note: Long runs should be avoided.
1. Terminate the outside air pipe below the exhaust vent outlet.
 2. 5. An open mesh screen should be placed over the outside air pipe opening to prevent birds or rodents from nesting in the opening. Use an elbow or shield to prevent prevailing winds from blowing directly into the outside air intake pipe. NOTE: Mesh screen should be no smaller than one-fourth inch (1/4") by one-fourth inch (1/4").

WARNING: OUTSIDE COMBUSTION AIR IS REQUIRED FOR ALL MOBILE HOME INSTALLATIONS!

Mobile Home Installation

Unit must be installed in accordance with the:
Manufactured Home and Safety Standard (HUD), CFR 3280, Part 24

Unit may be installed in a Mobile Home, after the initial sale of the Mobile Home, not for Recreational Vehicles. The following installations are approved:

1. In a Masonry Fireplace – The Masonry Fireplace must be built according to the requirements of the **Standards of Chimneys, Fireplaces, Vents and Solid Fuel Burning appliances, N.F.P.A. 211** and any National, State or Local codes that apply.
2. In a Zero Clearance Fireplace – The Factory built Zero-Clearance Fireplace and its Chimney must be listed per UL 127 or ULC S610 standards.
3. As a Zero Clearance Fireplace. **When building the unit in as a Zero-Clearance Fireplace, St. Croix factory Built Cabinet, part # 80P53963, must be used.** Follow instructions on page 11.

Mobile home installations must observe the following:

1. WARNING: DO NOT INSTALL IN A SLEEPING ROOM.

2. WARNING: COMBUSTION AIR MUST COME FROM THE OUTSIDE OF THE MOBILE HOME! FAILURE TO DO SO MAY CREATE NEGATIVE PRESSURE WITHIN THE MOBILE HOME AND COULD DISRUPT PROPER VENTING AND OPERATION OF THE PELLET STOVE.

3. CAUTION: THE STRUCTURAL INTEGRITY OF THE FLOORS, WALLS, CEILING AND ROOF MUST BE MAINTAINED.

4. Electrically ground the insert to the metal chassis of the home. Use a number eight, (8), gauge or larger copper wire, (Y).
5. Maintain an effective vapor barrier at location where PL vent exits the structure.
6. Check any other local building codes or other codes that may apply.
7. Do not use components other than those specified for use with this unit.
8. Floor protection requirement must be followed precisely.
9. Approved Venting materials are Single Wall Stainless, Stainless Flex, PL Vent and Corn Vent.

USE OF A THERMOSTAT

The Ashby-P offers our customers the optional feature of thermostatically controlling your new stove. By using a thermostat to control the operation of your Pellet stove, you can benefit two ways. First of all, after setting the thermostat to your desired heating needs the stove will operate accordingly to uniformly maintain your desired temperature setting. Secondly, the fuel consumption is being optimized, which ultimately results in lowering your seasonal heating costs.

While the room temperature remains cooler than your desired thermostat setting, the stove will operate at any of the 5 HEAT ADJUST selector positions. Read the Operations manual to determine which Thermostat Mode you want to use. You can choose between the T-Stat Mode and the Smart-Stat mode

1. Once you have successfully lit your stove, set the thermostat to your desired heating needs.
2. Set the HEAT ADJUST selector to a position that will effectively create a rise in room temperature above your thermostat setting. The recommended heat settings while using a thermostat are any Heat Level between 2 through 5.

Thermostat Hook-up

To hook up a thermostat connect the wires from the thermostat to the two white wires with red stripes in the harness. These wires are located on the right side of the stove and are labeled T-Stat.

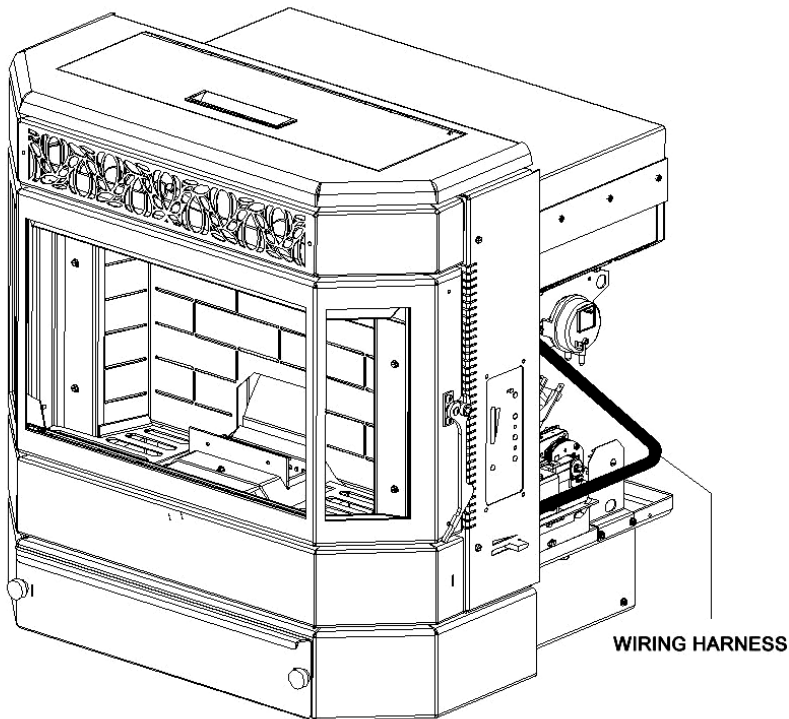

NOTE: Installers must determine a neutral location of where to mount the thermostat panel in order for accurate room temperature measurements.

Read the Frequently Asked Questions section in the Operations Manual to Troubleshoot the Thermostat.

CONNECT THE THERMOSTAT TO THE 2 WHITE WIRES WITH RED STRIPES IN THE HARNESS

Figure 16

Ashby-P Operation

CAUTION: Operate this unit only with the fuel hopper lid closed. Failure to do so may result in emission of products of combustion from the hopper under certain conditions. Maintain hopper seal in good condition. The auger will be prevented from operating by a hopper lid switch. Close lid immediately after filling hopper with fuel.

INSTALLATION CHECK

Proper installation is essential for safety, effective Operation, Warranty Coverage, Insurance requirements and to meet Local Building Codes. Installation Requirements are described in the first section of this manual. Verify the installation is correct before firing up the Ashby for the first time.

When burning a mixture of Pellets and Corn, care should be taken in how the venting system is installed. To mix Corn with Pellets, the moisture content of the Corn should be 15% or less. This is much higher than the moisture content of wood pellets and can result in condensation forming in the venting system in certain installations. The chimney system should stay within the warm envelope of the house as much as possible. Only penetrate the exterior of the home where the exhaust system will terminate.

REMEMBER: Condensation from burning corn is detrimental to the venting system. If burning a mixture of Pellets and Corn only buy venting systems that are warranted with burning corn.

PREVENTING CHIMNEY FIRES

Chimney fires can be prevented by properly operating the Ashby-P and by periodic inspection and cleaning of the chimney. When wood is burned it produces tar and other organic vapors, which combine with expelled moisture to form creosote. The creosote vapors condense in the relatively cool chimney flue associated with a slow burning fire. As a result, creosote residue accumulates on the flue lining. When ignited, this creosote can result in an extremely hot chimney fire.

The chimney and chimney connector should be inspected at least once every two months during the heating season to determine if a **creosote build-up** has occurred. If a significant layer of creosote has accumulated (3 mm or more) it should be removed to reduce the risk of a chimney fire. Use of an appropriately sized chimney brush or the services of a professional chimney sweep are recommended.

The chimney and chimney connector should be inspected at least once every two months during the heating season to prevent the system from getting **plugged with Fly ash**. Clean the exhaust system if needed. Use of an appropriately sized chimney brush or the Services of a Professional chimney sweep are recommended.

ASHBY-P APPROVED FUELS

PELLETS - Contact your dealer for more information on PFI approved wood pellet fuels.

The Ashby-P is not warranted against damage caused by using poor pellets, incorrect operation, improper maintenance or incorrect installation.

CHERRY PITS - No Standard exists for Cherry Pits used as Fuel. *Inspect fuel before buying.*

The Ashby-P was tested using Cherry Pits as a fuel by Intertek Testing Services, an independent Lab. Burning Cherry Pits requires the operator of the stove to monitor the fuel supply to make sure it is a viable product to use as a fuel.

The Ashby-P is not warranted against damage caused by using poor quality Cherry Pits, incorrect operation, improper maintenance or incorrect installation

50/50 PERCENT MIXTURE OF PELLETS AND CORN

The shelled corn used to mix in with the Pellets must be 15% or less moisture content. The keys to satisfactory performance are: proper operation of the stove, diligent maintenance and burning only dry, clean, quality corn. Corn dust must be screened prior to using.

NOTE: Corn with excessive grain dust must be screened, by sifting with 3/16" mesh screening. Large pieces of cob may plug the auger.

Clinkers and ash are a by-product of burning corn and are not caused by your stove. Stove performance can be quickly and severely reduced if poor quality corn is used. Contact your dealer for more information on where to get high quality corn to burn in your new corn stove.

Store corn in a tight container use other methods to ensure they do not become rain soaked or absorb moisture from damp or wet floors. This will also prevent rodents from becoming a problem. Do not store corn within stove installation clearances or within the space required for clinker removal.

The Ashby-P is not warranted against damage caused by poor quality corn, incorrect operation, poor maintenance or incorrect installation.

Ash Pan Location

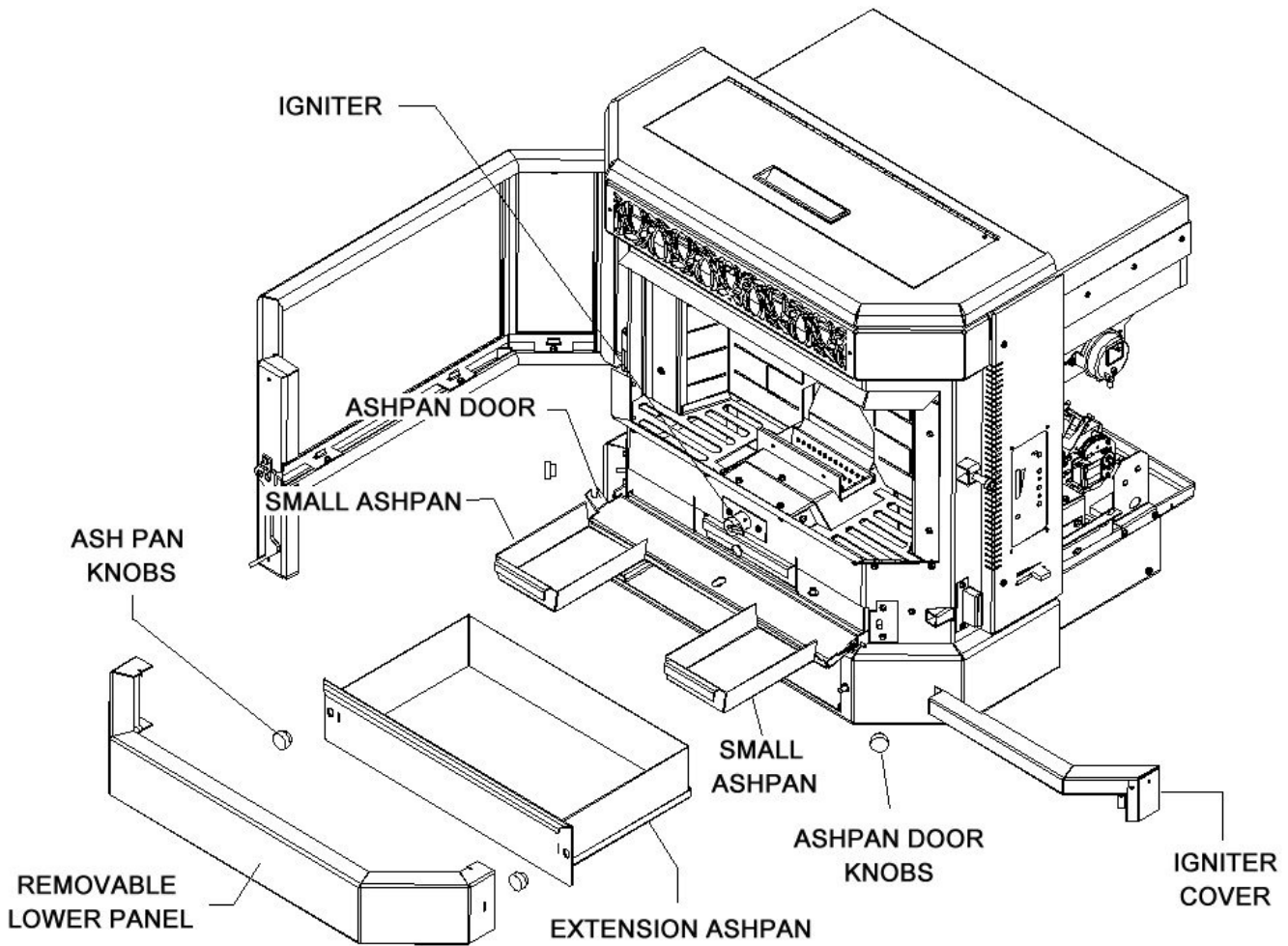

Figure 17

The above figure shows how to access the firebox ash pans, by removing the lower panel and opening the firebox ashpan door.

The Removable Lower Panel is held in place by Magnets. Simply hold each side of the Panel and lift off of the insert. The 2 small Ash pans are located behind the Ashpan Door.

Figure 17 also shows the location of the Igniter that lights the pellets during ignition.

OPERATING INSTRUCTIONS

A different type of heater. FOLLOW THESE OPERATING INSTRUCTIONS EXACTLY AS STATED TO ENSURE SAFE AND RELIABLE OPERATION.

1. Carefully read this “Operation and Maintenance” manual in its entirety BEFORE lighting your Insert for the first time.
2. Obtain final inspection and approval of installation from local building officials.
3. Have your dealer demonstrate all the operational and maintenance steps necessary for proper use of the Ashby. **Sign and return the warranty card** to the address listed on the back page.
4. Some odors may be given off during the first few hours of burning during initial break-in. These odors are normal and not harmful. However, ventilating the room until the odors disappear is recommended.
5. The Ashby will become HOT while in operation. Keep children, clothing and furniture away from all hot surfaces.

WARNING: Direct contact with the firebox during operation may cause skin burns.

6. To avoid the possibility of smoke and/or sparks entering the room always keep firebox and ash pan doors closed whenever the Insert is operating.
7. A certain amount of carbon monoxide may be produced within the Insert as a by-product of combustion. All exhaust vent connections must be sealed with **RTV silicone** to assure a gas tight seal. **Any leaks into a confined area caused by faulty installation or improper operation of the Ashby could produce dizziness, nausea and in extreme cases, death.**
8. Under certain circumstances an outside source of combustion air may be needed and is required on all mobile home installations. If room air is used to supply combustion air, room air starvation, operation of exhaust fans and icing of air vents can adversely affect proper operation.
9. Smoke detectors, installed in the same general area as the Ashby, may be activated if the insert door is left open and smoke is allowed to enter the area.

CAUTION: NEVER ADD FIRE STARTER TO A HOT STOVE.

CAUTION - Hot Surfaces

- **Keep Children away.**
- **Do not touch during Operation.**

Control Board Features

The Control Board controls all functions of the Ashby-P by monitoring sensors that are in the system. These sensors serve 2 purposes.

- a. General Operation of the Insert.
- b. Safety Features, to shut the unit down in the event the sensors detect a problem in the unit.

The Control Board also has Diagnostic Capabilities to help in diagnosing 3 areas in the Insert. These areas are:

1. High Temperature Limit.
2. Proof of Fire Sensor
3. Vacuum in the Firebox

A closer look at the Control Board to the right in figure 18 will explain how the board works. There are essentially 4 buttons on the control board. Two of these buttons, the **Heat Level** and **Trim** Buttons, have a High/Low side to advance these settings up or down. There is a **Slide Switch** that controls the Thermostat Mode and an **LED Light** bar that indicates which of the 5 Heat Settings the Ashby-P is running on.

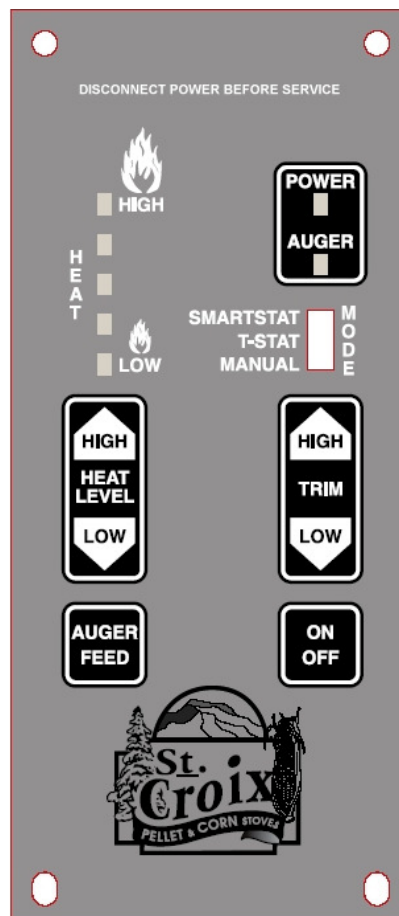

Figure 18

The LED Light bar is also used during the Diagnostic process, see page 34 for more details

1. The On/Off button not only turns the Ashby-P On and Off, *it also resets the board if one of the sensors has detected a problem and the board is flashing a Diagnostic code.*
2. The Auger Feed button will allow the user to manually auger fuel into the burn pot on start up when needed. This is particularly helpful in priming the Auger Tube when it is empty (After the hopper has run out of pellets). This button is also used to make small adjustments to the combustion air and the feed rates as part of the **Fine Tuning** process of the control board.

3. The Heat Level button will advance the setting up and down between level 1 and 5. It will also be used in the Fine Tuning process of the feed rates if needed.

To adjust the Feed-rates:

Hold the Auger Feed Button down and press the Heat Level High/Low button and this will change the ON Time up or down .25 seconds from the factory setting. Watch the LED lights to see the setting is on (it will flash the new setting). This new setting will stay in memory from this point on. The LED lights indicate the level of adjustment and the factory setting is the center LED light. This gives two .25 second adjustments up and two .25 second adjustments down.

4. The Trim button is used to adjust the Exhaust (Combustion) fan voltages up or down to provide for **fine-tuning** of the combustion air. The LED lights indicate the level of adjustment and the factory setting is the center LED light. This gives 2 adjustments up and 2 adjustments down.

To adjust the Combustion Fan voltages:

Hold the Auger Feed button down and press the Trim High/Low button and this will change the fan voltage approximately 2.5 volts up or down from the factory setting. Watch the LED lights to see the setting is on (it will flash the new setting). This new setting will stay in memory from this point on. **Use these adjustments in conjunction with the damper.**

5. The Thermostat Slide switch allows the Insert to be run in 3 different Modes:

a. **Manual Mode.** The Control Board controls all functions of the Ashby.

b. **T-Stat Mode.** *The Stove is Fully-Automatic in the T-Stat Mode. (T-Stat requires the stove be turned on at the control board the first time).* The unit is hooked to a Thermostat and when calling for heat the unit will advance to the Heat level set at the Control board. Once the Heat demand has been met, the Stove will immediately shut down. Use this setting when heating a small area or when Temperatures are Moderate. *Not recommended for use with a mixture of Pellets and Corn.*

c. **SmartStat Mode.** *(Can only be used with Pellets & Cherry Pits in the Ashby –P model. Not recommended for use with a mixture of Pellets and Corn.* The unit is hooked to a Thermostat and when calling for heat the Insert will advance to the Heat level set at the Control board. Once the Heat demand has been met the Insert will drop to the #1 Heat Level setting **and pilot for one hour**. If the Thermostat does not call for heat during that hour the unit shuts off and **re-lights itself the next time the Thermostat calls for heat**. This setting is best used during early Fall or late Spring, when constant heat is not needed.

6. **Cleaning Cycle.** The Ashby-P only uses Programs 3 & 4. This allows the Ashby-P to operate in an Automatic mode using the Igniter. These 2 programs have a Cleaning Cycle built into them that allows the unit to drop to the #1 level for 5 minutes on timed intervals. During the cleaning cycle the Combustion Fan will run at line voltage to blow excess ash from the burn pot. This feature only functions if the unit is operating on levels 3 through 5. **The ON/OFF light blinks during this cycle.**

Pre-Lighting Instructions

WARNING: - Risk of Fire.

- Do not operate with the Firebox door or Ash Removal doors open
- Do not store Fuel or other Combustible material within marked Installation Clearances.
- Inspect and Clean Flues and Chimneys regularly.

Danger: Risk of Fire or Explosion

- Do not burn Garbage, Gasoline, Drain Oil or other Flammable Liquids.

WARNING: The auger can start at any time while the Ashby is running

REMEMBER: Read the manual before lighting the unit.

The Control Board has 4 separate programs. Each program is specific to a certain fuel. Before lighting the Insert for the first time, be sure the correct program is chosen.

To change the program on the board, the Insert must be off and the unit must be cold. The programs are identical in operation, except for the Cycle Time. The Cycle time is the total of the ON Time & OFF Time added together. The ON Times are constant, so this means that the OFF Time is increased or decreased, depending on the program chosen.

- 1 - **Program 1.** The Cycle Time is 11.5 seconds. **THIS PROGRAM IS ONLY TO BE USED WITH THE ASHBY-MF MODEL. (DO NOT USE THIS PROGRAM WITH THE ASHBY-P).**
- 2 - **Program 2.** The Cycle Time is 13 seconds. **THIS PROGRAM IS ONLY TO BE USED WITH THE ASHBY-MF MODEL. (DO NOT USE THIS PROGRAM WITH THE ASHBY-P).**
- 3 - **Program 3.** The Cycle Time is 11.5 seconds. **THIS PROGRAM IS THE DEFAULT PROGRAM FOR USE WITH THE ASHBY-P.** This program is for use with **Pellets, Cherry Pits and a 50/50 Percent Mixture of Pellets and Corn (See fig. 19 on page 33).** **(DO NOT USE THIS PROGRAM WITH THE ASHBY-MF).**
- 4 - **Program 4.** The Cycle Time is 10 seconds. **This Program offers Self-Ignition and is only for units that have the Versa Grate system & Igniter installed.** This program is for use with **Cherry Pits. (See fig. 19 on page 33).** **(DO NOT USE THIS PROGRAM WITH THE ASHBY-MF).**

If the *incorrect* program is chosen for a specific fuel, the burnpot will overload. Use caution when using this feature. **The default program to use for the Ashby-P is Program 3.** Program 4 is for Cherry Pits and in some instances may be used to “Tweak” the unit for certain qualities of fuel and installation conditions. *(Ask Dealer before using program 4 for any other fuel than Cherry Pits.)*

Changing the program on the Control Board

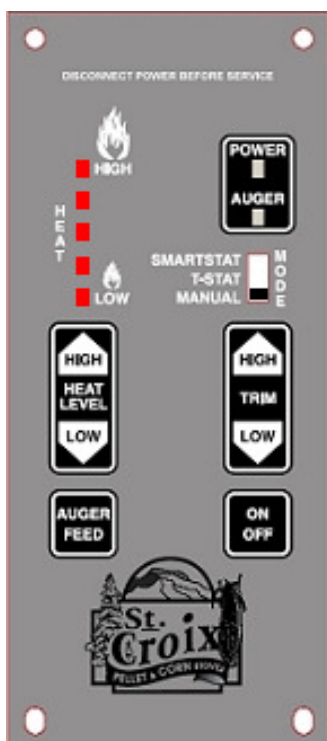

To change the Program the Insert must be in the OFF position, the unit must be completely cooled down so the Proof of Fire Switch is Open and the Thermostat slide switch must be in the Manual mode. (See figure 19)

Press & hold the Auger Feed Button, then press the Trim **High & Low** Button at the same time. The LED lights that indicate the heat level will flash. The number of times the lights Flash will indicate which program is running.

Program 1 – LED lights flash *once*

Program 2 – LED lights flash *twice*

Program 3 –LED lights flash *three times*

Program 4 – LED lights flash *four times*

Figure 19

Lighting Your Ashby-P with the Versa Grate System. (Program 3 & 4)

1. Make sure there are pellets in the hopper and the viewing door and ash pan door are closed.
2. Push the On/Off button on the control board. (See figure 19 on page 34)

At this point all that needs to be done is to monitor the burn pot to make sure the stove starts up properly. Once the On/Off button has been pushed the Start Up program takes over.

The Start up Program works as follows:

- a. The Combustion fan and Room fan come on at high speed and the control board checks to make sure the Vacuum switch locks in. (See Diagnostic features on page 34 and 35)
- b. When the board senses the Vacuum switch the Combustion fan drops to the #1 setting and the Room fan shuts off.
- c. The Igniter and the Auger come on (the Auger runs for 2 minutes). The stove will typically light in the first 3 - 4 minutes. After 5 minutes the board checks for “Proof of

- Fire” and starts feeding pellets on the #1 setting. Once the board senses P.O.F. the Igniter shuts off and the stove has started successfully.
- d. If the board fails to sense P.O.F. it will repeat the previous step and continue feeding pellets on the #1 setting for 5 more minutes.
 - e. The board will check for P.O.F. one more time. If the board still fails to sense the Proof of Fire switch, the stove will go into “Safety shutdown” (See Diagnostic Features on page 35)

If the stove fails to start, repeat steps listed above.

CAUTION: NEVER ADD FIRE STARTER TO A HOT STOVE.

Shutting the Unit Off

1. Press the On/Off switch once; the lights will go off and the fire will go out in a few minutes. The board essentially goes into “Safety shutdown”.
2. As long as the temperature within the Ashby-P remains above 110°F the Fans will continue to run. When the P.O.F. switch drops out, the room fan shuts off and the Combustion fan will run for another 10 minutes and finally shut down completely.
3. NEVER unplug the Insert to shut it off. Doing so may cause a significant amount of smoke to enter the room.

Diagnostic Features of the Control Board

The #2 LED, #3 LED and #4 LED lights on the LED Light bar) will flash to give a diagnostic code to help in diagnosing problems that may occur. *(Read Frequently Asked Questions for more information)*

These conditions fall into 2 categories:

- a. Heat related issues.
- b. Vacuum related issues.

The Diagnostic Lights flash as follows:

1. The **Proof of Fire** switch. This switch will sense the temperature of the Exhaust rising during start up. If the Exhaust temperature does not reach 110 degrees F, or if, during use, the temperature drops below 110 degrees F, the Insert will go into “**Internal Alarm**” and the Auger will quit feeding fuel. Once the Insert completes the safety shutdown, the #3 LED will start blinking. *(Read Frequently Asked Questions for more information)*
2. The **High Limit** switch. This sensor will sense if the unit reaches temperatures that are too high for normal operation. If this happens the Auger will quit feeding and the #4 LED light will start blinking. *(Read Frequently Asked Questions for more information)*
3. The **Vacuum** switch. For the Insert to operate correctly the firebox needs to be sealed. During the first 30 seconds after the unit has been turned on, the control board will check to see if the switch senses negative pressure (Vacuum) in the firebox of the Insert. If there is no negative pressure, the Insert will go into “Safety shutdown” and the #2 LED will start blinking. *(Read Frequently Asked Questions for more information)*

During “Normal Operation” a 60 second delay has been incorporated before the unit shuts down when the board senses loss of vacuum. This is to accommodate opening the doors during maintenance. Once the board senses loss of vacuum the ON/OFF light will start blinking. While the light is blinking the control board will not feed any fuel nor respond to any of the buttons. Once Vacuum has been restored the unit will revert to normal operation.

“Internal Alarm” - When the control board becomes unresponsive, the control board is in Internal Alarm. The control board has sensed one of the Safety sensors. This may cause the unit to go out and flash a Diagnostic Code. In some cases, after waiting approximately 45 seconds the Insert will start responding to the control board again. Many times, the cause of this is a change in the vacuum inside the firebox. This may be caused by excessive wind or by opening the Firebox door. The control board will monitor the vacuum switch and resume normal operation if the vacuum returns to normal.

“Power Reset” - If the board becomes unresponsive for a long period of time, you must unplug the Insert, wait 10 seconds and plug the unit back in to reset the board.

Safety Features

1. **”High Limit” switch**, an overheat safety switch will shut off the fuel feed if the Insert reaches temperatures above normal operating temperature. This is a “Normally Closed” switch. If the High limit switch trips several times, the problem in the Insert *must* be diagnosed before the unit is put back into service, (Defective Room Fan, dirty Room Fan, defective High Limit switch or possibly a bad Control Board)
2. **Vacuum switch** also called the **Negative pressure switch**. When the Insert is turned on the Exhaust fan will create a negative pressure in the firebox. The control board continually checks to see if Negative Pressure (vacuum) is present during operation of the Insert. If the exhaust venting system becomes clogged or obstructed, the firebox door is left open or the exhaust fan quits working the control board will go into “Safety shutdown”. There is a 60 second window to allow for cleaning the glass before then unit shuts down. This is sufficient for the Daily Maintenance
3. **Proof of Fire switch** also called the **P.O.F.** This senses the temperature rise in the exhaust system. The switch is “Normally Open” and closes the circuit at 110 degrees. The Insert will shut down if temperatures above 110 degrees F are not sensed during start up or if the temperature drops below 110 degrees during normal operation.
4. **Hopper Lid Switch**. The hopper lid switch will shut off the auger motor when the hopper lid is open. Be sure the lid closes completely when refilling the hopper or the unit will shut down
- 5.

WARNING: The Insert has been Safety Tested by an accredited, independent laboratory. These safety features are designed to protect life and property. Bypassing these features voids all warranties and the safety listing of the Ashby-P.

Combustion Air Damper

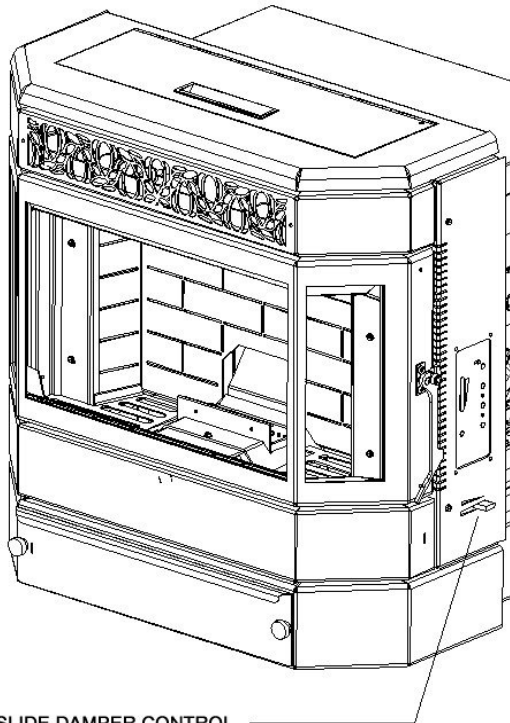

Do not neglect to adjust the Combustion Air damper during the break in period of your new Insert (See Figure 20 to the left). Your Ashby-P Insert is equipped with an air inlet damper. The purpose of this damper is to adjust combustion airflow to match the characteristic of each specific air inlet and chimney configuration. The damper will most likely only need a small adjustment during the break in period. To know if the damper needs to be adjusted you should learn to recognize how Pellets burn in the Ashby-P Insert with the Versa Grate system.

Figure 20

Procedure for adjusting the damper when burning the Ashby-P:

When burning the Ashby, the adjustment to the damper must primarily focus on how Insert runs on the low setting. (Read “*PREVENTING CHIMNEY FIRES*” on Page 26)

- a. If a *heavy black shiny build* (difficult to wipe off) up is noticed (on the glass and inner surfaces) after the unit runs on the low (pilot) setting for extended periods of time, the damper must be closed some. This may not show up until the Insert runs in pilot mode (Heat Level 1) for an extended period of time. If this build up occurs, slide the damper control $1/16^{\text{th}}$ at a time to close the damper until the glass improves. Some build up is normal and may be removed during the maintenance schedule.
- b. Once the adjustment has been made for the pilot setting (Heat Level 1), slowly advance the Control Board to the #5 Heat Level and observe the flame. If black soot (wipes off easily) builds up on the glass and black smoke is visible at the tips of the flames, slide the damper control $1/16^{\text{th}}$ at a time to open the damper. Wait 5 – 10 minutes before attempting another adjustment. An occasional wisp of black smoke is normal.

If the damper seems to be set correctly for level 5, but there seems to be too much air for the lower settings, then adjust the combustion fan voltages by using the control board. (See point 9 in the *Troubleshooting & Frequently Asked Questions Section* in the back of the manual)

If the Ashby has been connected to an existing Chimney system that has good natural draft, use the Trim button to adjust the Combustion Fan voltages down to compensate for the extra draft.

If the Insert has been installed as a “Zero-Clearance” fireplace, and the vent system has horizontal venting and elbows, there will be more restriction in the venting system and more air may be needed.

Thermostat Control & Pilot Settings

The Ashby-P may be controlled with a thermostat to help maintain a more constant temperature. The Ashby-P may react a little slower to a thermostat compared to a Gas or Electric insert. With this in mind the low setting can be adjusted to increase or decrease the amount of fuel used. This will allow the heat output during the pilot stage to be matched to the size of the home. A larger home will require more heat than a small one. Keep in mind that the Insert is constantly producing some heat that helps heat the home while it is in pilot mode. If the home seems too warm, and the Thermostat is never calling for heat, a lower pilot setting may be a better fit for the home. *(Read point 3 on page 31 for adjusting the feedrates on the low setting). Running the unit in the Smart-Stat mode will also allow the unit to shut down if the Thermostat doesn't call for heat with in an hour.*

Remember: Choosing a lower Pilot setting may require the Draft Fan Voltage or the Damper to be fine-tuned to match the lower feed rate. Monitor how the Ashby is operating after a change is made and adjust the damper or Combustion Fan voltage if needed.

Ashby-P Maintenance

NOTE: WHEN YOU FIRST OPERATE YOUR ASHBY-P INSERT, CHECK TO DETERMINE THE NEEDED CLEANING FREQUENCY. THE ASHBY-P REQUIRES A MINIMUM AMOUNT OF DAILY MAINTENANCE. REQUIRED MAINTENANCE DEPENDS LARGELY UPON THE QUALITY OF FUEL BURNED AND THE RATE OF BURN. THE AMOUNT OF DAILY MAINTENANCE WILL INCREASE IF FUEL QUALITY DECREASES AND/OR THE BURNING RATE OF THE FUEL INCREASES.

NOTE: FAILURE TO KEEP YOUR INSERT CLEAN, AS DESCRIBED IN THIS MANUAL, COULD RESULT IN POOR OPERATION, INEFFICIENT FUEL USAGE AND A POSSIBLE SAFETY HAZARD! IT IS THE RESPONSIBILITY OF THE OWNER/USER TO DETERMINE THE NEEDED MAINTENANCE FREQUENCY.

CAUTION: THE DOOR AND FRONT PART OF THE INSERT WILL BE HOT. DO NOT TOUCH ANY PART OF THE UNIT THAT IS HOT!

The Versa Grate System

MAINTAINING THE STOVE - The stove requires a minimum amount of daily maintenance. Required maintenance depends largely upon the quality of pellet fuel burned and the rate of burn. The amount of daily maintenance will increase if fuel quality decreases and/or the burning rate of pellets increases.

The benefit of this feature is that the stove can operate for longer periods of time, with most fuels, without the grate requiring cleaning. If the flame becomes dark orange, is accompanied by black smoke or burns with a lazy motion - it's time to clean the grate **When you first operate your stove or whenever you change fuels check to determine needed cleaning frequency.** (See Figure 25).

First, let's become familiar with the burn system in a St. Croix Pellet stove. Remember, cleaning frequency may change dramatically from one fuel to another. Pellets with high ash content or that have increased amounts of impurities or high moisture content. Every St. Croix Pellet stove model will have the same system as shown in figure 25 below. There is a 2-piece burnpot. The top Part is called the **"Grate Weldment"**. This sits on top of the **"Shaker Plate"**. This in turn sits on top of the **"Shaft/Cage Weldment"** and is held in place with the **"Spacer"** & **"Self Locking Twist pin"**. The Shaft/Cage weldment is moved towards the front of the stove and then towards the back of the stove by the **"Cam"** that is connected to the **"Versa Grate Motor"**. This motion is constant, while the stove is in operation.

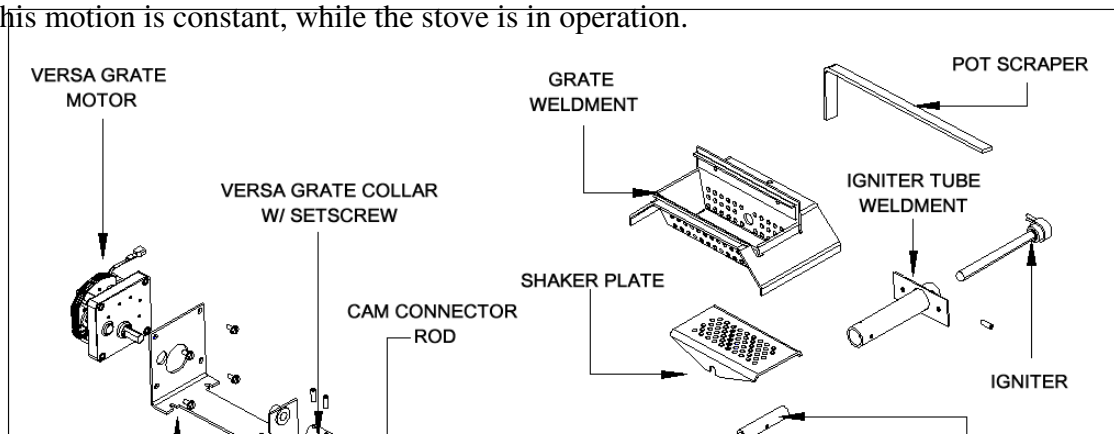

Figure 25

Daily Maintenance – Ashby-P

CAUTION: THE DOOR AND FRONT PART OF THE STOVE WILL BE HOT. DO NOT TOUCH ANY PART OF THE STOVE THAT IS HOT! CAUTION: NEVER ADD FIRE STARTER TO A HOT STOVE.

1. Check Grate Weldment and Shaker Plate (See figure 26) to determine if holes are plugged. Clean as needed. With proper precautions the grate may be partially cleaned while the stove is hot. Follow these steps:
 - a. Wear a leather glove that covers the lower arm.
 - b. Turn the Stove to Heat Level 1 and allow the flame to burn down to a low burn.
 - c. Open the firebox door slowly to prevent drawing ash or odors into the room.
 - d. Use the “scraper” provided to move the burning pellets to one side of the grate, leaving the ash in the bottom of the grate. (See Fig 25)
 - e. Rake the ash & clinkers out over the grate into the ash pan.
 - f. Rake the burning pellets across the bottom of the grate.
 - g. Close the door and re-select the desired heat setting.

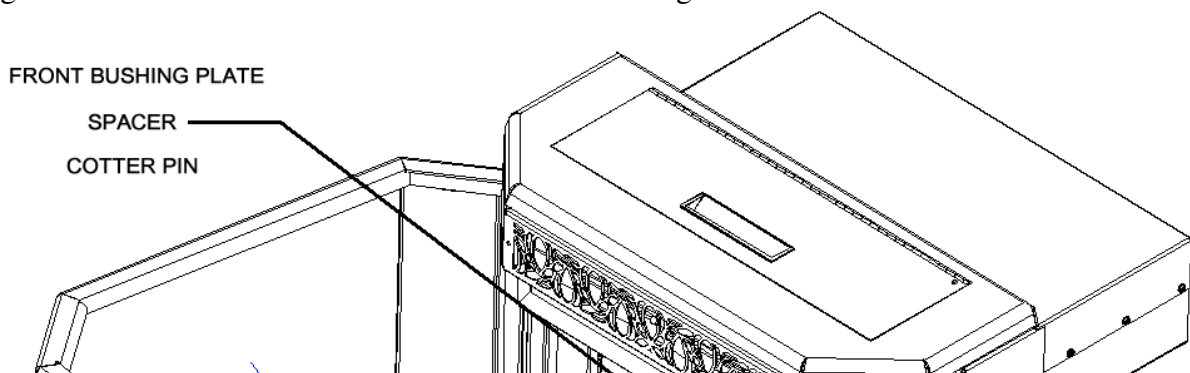

Figure 26

The “Grate Weldment” and the “Shaker Plate” may need to be removed for cleaning purposes during the Daily or Periodic Maintenance if the holes have become plugged. This allows a closer inspection of the holes in the pot. Use a 3/16” drill bit to clean out the holes if needed.

2. ***If the removable large bolt on ashpan is not used*** remove ash buildup under the Shaker Plate daily or as frequently as needed. This area will fill up with ashes that drop through the “Shaker Plate”. Once this area gets plugged, it will choke off the flow of Combustion Air to the Burn Pot, causing the flame to be lazy.

3. Check ash pan (*See Fig. 1 on page 6*) to determine emptying frequency needed. NOTE: Do not use a vacuum cleaner for this purpose. Hot coals may cause your vacuum filter to catch fire. Place ashes in a metal container with a tight fitting lid. The closed container of ashes should be placed on a noncombustible floor or on the ground, well away from all combustible materials, pending final disposal. If the ashes are disposed of by burial in soil or otherwise locally dispersed, they should be retained in the closed container for at least two days until all cinders have thoroughly cooled.

4. Once or twice daily pull the Heat Exchange Tube Scraper, (*See Fig. 1 on page 6*) out and back to clean heat exchange tubes. Failure to operate the tube scraper daily may result in poor combustion and loss of heat output. This should be done when the stove is cool or operating on the low temperature setting. Use the Rod Pull Tool to reach the Tube Scraper Rod.

5. The rate of burn and the quality of fuel will determine how often the window needs cleaning. Prolonged burning at a slow burn rate will result in the need for more frequent window cleaning. Burning poor fuel also increases the need to clean the window. Cooling the stove and wiping the window daily with a cloth or paper towel will normally keep the window from accumulating difficult to clean residue. Use of a glass cleaner ONLY permitted when the stove is cold. *Tip: Dip the damp towel in the ashes to remove stubborn buildup on the glass.*

CAUTION: Do not slam the door. Do not operate the stove with a broken or cracked glass. Replace only with heat resistant ceramic glass supplied by the manufacturer.

6. Burn the stove at the HI fuel setting for at least 30 to 60 minutes each day. This helps keep the window, firebrick and firebox area clean. A daily high burn also aids in maintaining the overall efficiency and performance of the stove.

Periodic Maintenance

CAUTION: Periodic maintenance should only be done while the Insert is shut off and cold.

1. **Ashpan.** Empty the ash pan when it appears full (approximately once a week). The frequency of cleaning the ash pan will depend on the quality and amount of fuel being used. Carefully check to make sure the ash pan door is tightly closed after each opening. *If the removable large bolt on Ashpan is not used, more frequent dumping of the three smaller Ash Pans will be required*
2. **Grate Weldment and Shaker Plate.** Clean Grate Weldment and Shaker Plate holes whenever needed. Remove the Burnpot and use a small metal object (Nail, Drill Bit, etc) to clean out plugged holes. (*See Figure 26*). The Grate Weldment and Shaker Plate holes can also be cleaned without removing them by using a small steel brush to clean the holes.

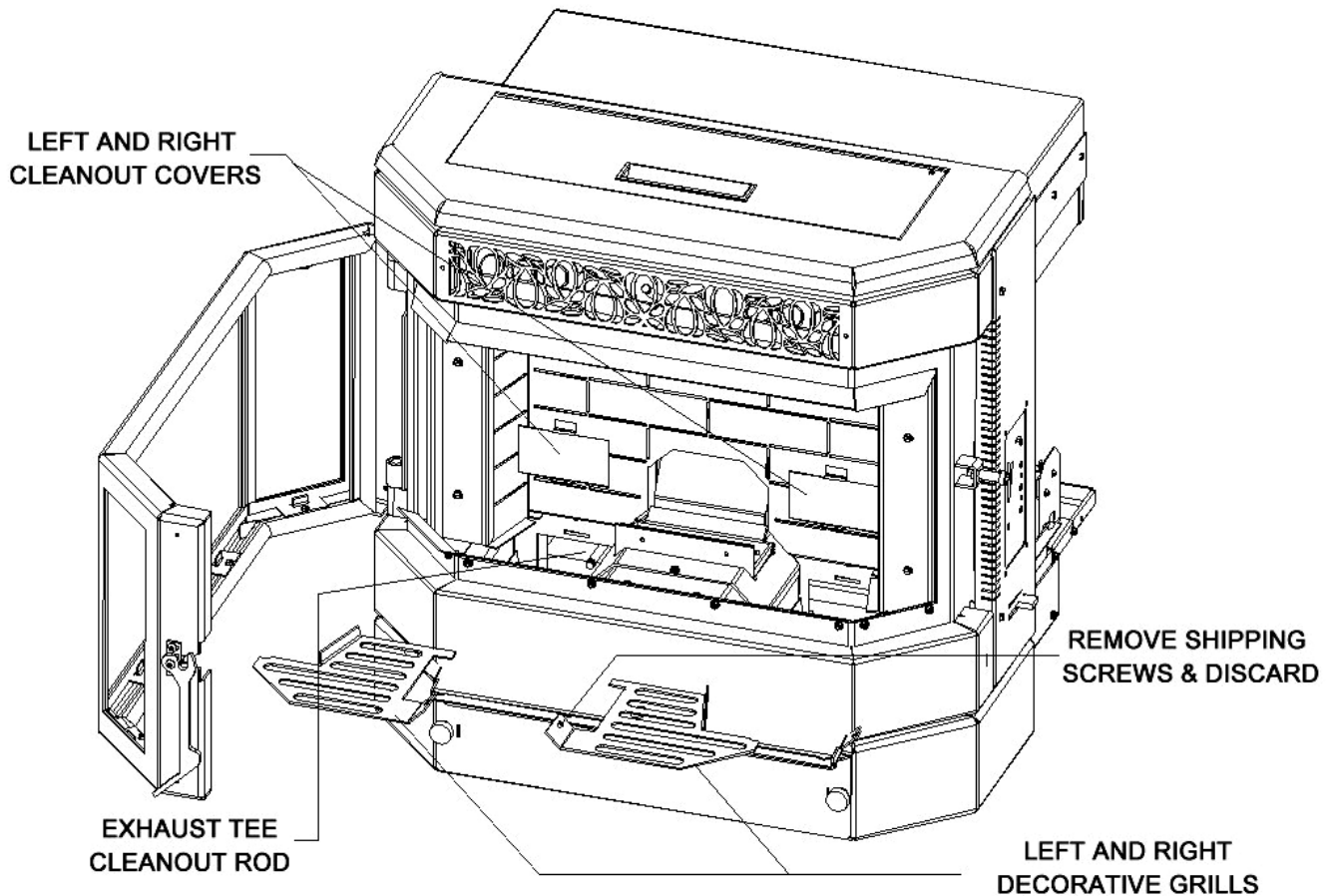

Figure 28

3. **Clean-Out Ports.** The Ashby-P Insert has 2 Exhaust Cleanout Ports located in the LEFT AND RIGHT lower corners of the firebox. Remove covers and clean regularly

Figure 28 also shows the location of the Exhaust Tee clean-out rod. The insert has a built in cleanout to be able to vacuum the buildup that accumulates in the vent system from the front of the unit without having to pull the unit from the fireplace. Figure 29 shows the area that can be reached with a vacuum cleaner without having to pull the insert from the fireplace. The Exhaust Tee Cleanout Rod must be pulled forward to open the Cleanout Tee. Cleaning this area on a regular basis will prevent the vent system from becoming plugged with fly-ash. The recommended size of the hose to use for vacuuming this area is 1.25" outside diameter. The hose should be inserted into the left Cleanout Port and vacuum all the way back to below the built in Tee as shown in Figure 29. ***Push the Rod back in to close the bottom of the Cleanout Tee.***

Frequency of cleaning depends on the amount of fuel being burnt and the quality of the Fuel.. **Failure to clean the ash traps will cause the Insert to become plugged with Fly Ash.**

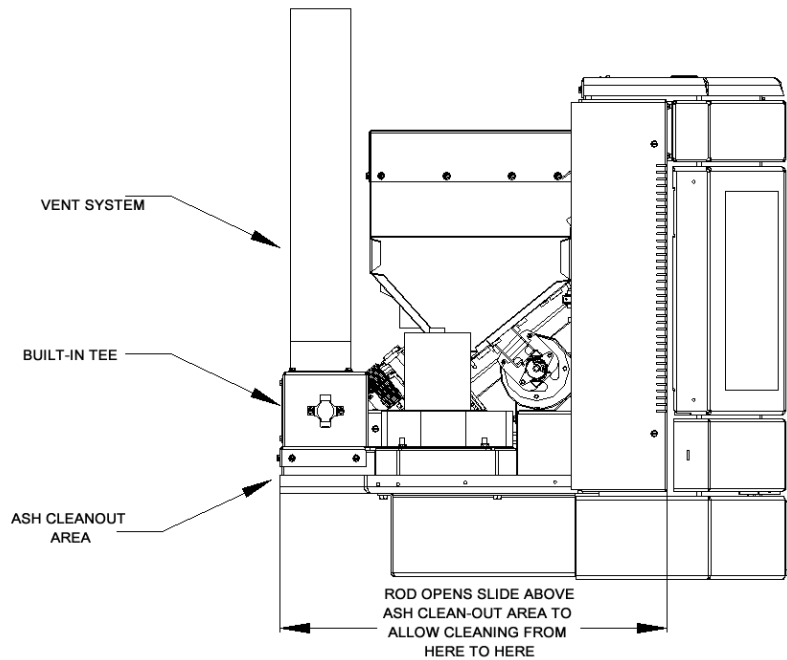

Figure 29

1. **Heat Exchange Baffle.** Remove the baffle and clean the ashes that accumulate on a regular basis. Once a month or sooner, depending on the quality of fuel being used (*See Figure 30*)

Clean the baffle on a regular basis. Frequency of cleaning depends on amount of fuel being burnt and the quality of the fuel. Fuel with low ash content is recommended. **Failure to clean the baffle can cause the Ashby-P Insert to become plugged with fly ash.**

To remove the baffle, simply lift the baffle up off of the brick and remove from the insert.

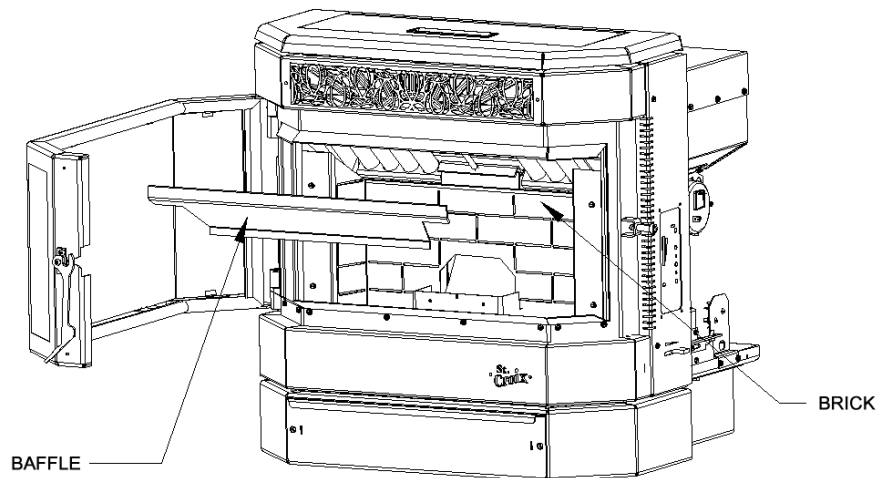

Figure 30

2. **Exhaust System.** See Figure 28 and 29 for information on cleaning fly ash that collects in the vent system. Periodic cleaning of the exhaust system is required. Under certain conditions

chimneys may plug up rapidly. Dirty poor quality Fuel, and poor installations require more frequent chimney cleanings. The products of combustion will also contain small particles of fly ash. The fly ash will collect in the exhaust vent and restrict the flow of the flue gases. Judge the frequency of cleaning by checking the amount of ash that accumulates in the built in Cleanout Tee in the exhaust system. Ask the dealer for suggested frequency of cleaning, equipment needed and procedures for cleaning. Check the Vent Cap at least once every two months during the heating season to see if it has become plugged. **See Page 26 “Preventing Chimney Fires”.**

3. **Gaskets.** Periodically inspect the condition of the rope gasket around the door, window and ash door. Replace as needed.

Yearly Maintenance

Many dealers offer a Service Contract that will cover Yearly Maintenance. Contact your St. Croix Dealer for assistance in maintaining your Ashby-P in top condition. Yearly maintenance is designed to assure safe operation, prolong the life of the Ashby and help preserve its aesthetic appeal.

1. **Spring Shutdown.** After the last burn in the spring let the unit cool down. Remove all fuel from the hopper and the auger. Thoroughly clean the burn pot, burn pot box, ash pan and ash traps behind the ash pan. (To locate the ash traps see figure 28)
2. The exhaust system should be thoroughly cleaned at least annually. Call your dealer for this service. (See figure 31 on the following page)
3. The motor/fan area behind the firebox and under the hopper should be vacuumed annually. (See figure 31 on the following page)

NOTE: UNPLUG THE INSERT. Remove the Surround panels of the Ashby-P and pull the unit from the fireplace. Carefully clean or vacuum any dust, cobwebs and household dust. Carefully vacuum around the fan motors. If electrical wires become disconnected call your dealer for service.

4. The exhaust fan should be removed and cleaned with compressed air annually. Call dealer for this service. Annual oiling of the motors is not needed. (See figure 31 on the following page)
5. The Convection fans should be removed and cleaned with compressed air annually. (See figure 31 on the following page)

Fall Startup. Prior to lighting the first fire check the outside area around the exhaust and air intake systems for obstructions. Try all controls to see that they are working prior to lighting a fire.

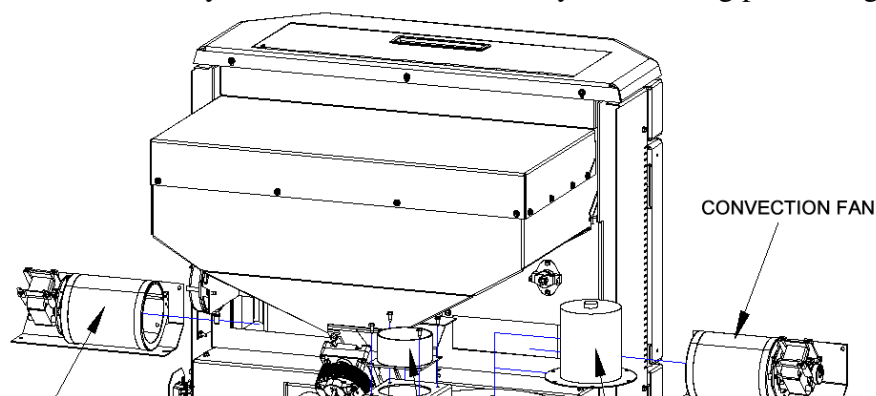
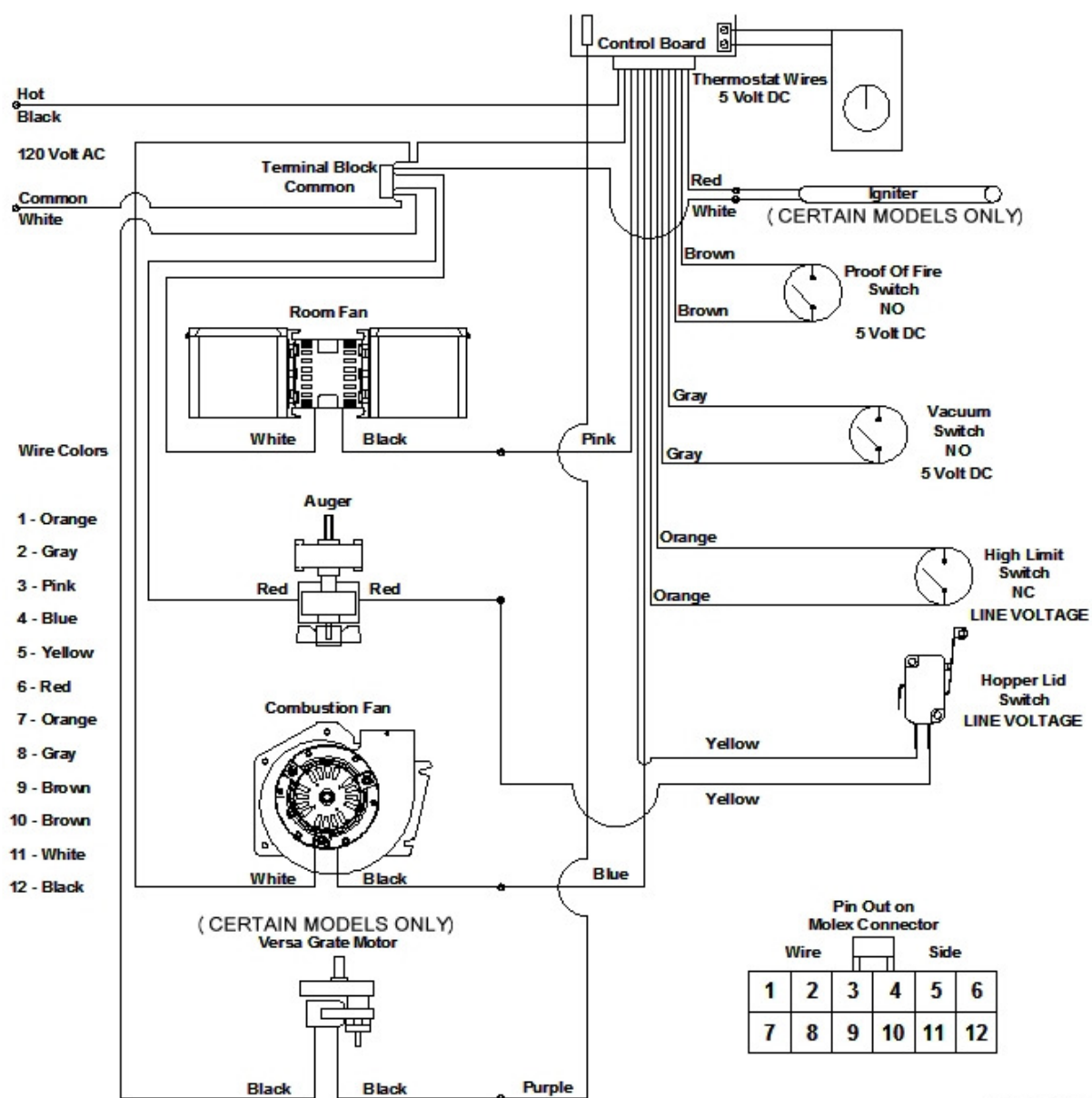

Figure 31

SAFE OPERATION.

1. **Disposal of Ashes.** Ashes should be placed in a metal container with a tight fitting lid. The closed container of ashes should be placed on a non-combustible floor or on the ground, well away from all combustible materials, pending final disposal. If the ashes are disposed of burial in soil or otherwise locally dispersed, they should be retained in the container until all cinders have thoroughly cooled.
2. **Never use Gasoline,** gasoline type lantern fluid. Kerosene, charcoal lighter fluid or similar liquids to start or “freshen up” a fire in this heater. Keep all such liquids well away from the heater while it is in use.
3. **Creosote, Soot and Fly Ash:** Formation and Need for Removal. The products of combustion will contain small particles of Fly Ash. The fly ash will collect in the venting system and restrict the flow of flue gases. Incomplete combustion, such as occurs during start-up and shut-down, or incorrect operation of the room heater will lead to some soot or creosote formation which will collect in the venting system. The exhaust system should be inspected regularly during the heating season to determine if creosote buildup has occurred. Check more frequently at first to determine a schedule for cleaning the venting system based on individual use of this Insert. If creosote has accumulated, it should be removed to reduce the risk of a chimney fire.
4. **Do not Overfire this unit.** Follow all instructions regarding the proper use of this heater.

Wiring Schematic



80P30563

Figure 32

The Electrical Rating of this Ashby-P Insert is: 120 Volt, 60 Hz, 4 Amp with the igniter running and approximately 2 Amp with out the igniter running. The minimum recommended circuit is 15 Amp. A dedicated circuit for the Insert is recommended.

CAUTION: The electrical components of the Ashby-P are not owner serviceable. Call your dealer for proper diagnosis of electrical problems and service to those components.

TROUBLESHOOTING & FREQUENTLY ASKED QUESTIONS

The Insert is very trouble free in operation when properly maintained and quality fuel is used. When the Insert fails to operate properly, troubleshooting by the operator of the Insert is limited. Please read the following guide for answers to frequently asked questions

1. When first starting your Ashby-P the auger tube is empty, which will delay feeding fuel to the burn pot. This will in some cases prevent the Insert from starting.

Solution: Prime the burn pot using the Auger Feed button if the auger tube is empty.

2. **My Insert keeps overloading the burnpot.** First check the Quality of your Fuel to make sure you are using clean fuel. Otherwise this is mainly caused by improper combustion settings. (See *Damper Adjustment* section of the Operations Manual) Besides the damper adjustment there are several areas that can have an effect on the combustion process.

Solution: Check all Gaskets, Doors and Door Latching Systems for air leaks. Any leaks in these areas will negatively affect the burn process and cause the pot to overload.

3. **My Insert isn't burning and the number 2 LED light is blinking.** This diagnostic light indicates the vacuum switch no longer senses negative pressure in the firebox area of the Insert. What caused the Insert to go out?

- a. The door of the unit was left open longer than 60 seconds. (**See solution**)
- b. The ash pan door was left open for longer than 60 seconds. (**See solution**)
- c. The combustion fan is not running. (Defective fan or control board)
- d. The vacuum switch is defective.
- e. The vacuum hose is disconnected
- a. The vent system is plugged with fly-ash.

Solution: *If the fire is out*, re-light the Insert. *If the fire is still burning* make sure all doors are securely latched and hold down the On/Off button (approximately 5 seconds) until Insert starts up again. This will re-start the Insert in the start-up program.

4. **My Insert isn't burning and the number 3 LED light is blinking.** This diagnostic light indicates that the Proof of Fire Switch no longer senses a fire in the Insert. First check to see if there is Fuel in the hopper. If there is fuel in the hopper check the following items to figure why the Insert went out.

- a. Unburned fuel in the burnpot means the fire went out before the auger quit feeding.

Too much Combustion Air while burning on the Lowest Heat Level could cause the fuel to burn up too quickly and cause the fire to go out.

Solution: Too much Combustion Air on the pilot setting. Adjust the air damper or the combustion fan voltage. Fuel would still feed until the P.O.F. switch eventually shuts the Insert down. (See section covering *Damper Adjustment*)

- b. If all the fuel is burned up means the auger quit feeding fuel while there was still a fire in the burnpot. Check to see if there is fuel in the hopper. If the hopper is empty, fill the hopper and re-light the Insert.

If there is fuel in the hopper check to see if there is an obstruction in the auger system or if the auger set screw is loose.

Solution: Remove obstruction and re-light the Insert or tighten the setscrew on the auger shaft.

5. **My Insert isn't burning and the #4 LED light is blinking.** This means the high Limit has shut the Insert down. The Convection Blower could be defective or may need cleaning. The high limit switch may be also defective. It is best to call your dealer for support when trying to troubleshoot the High Limit Switch. Do not use your Insert if the High Limit switch frequently trips.
8. **I turned the Insert on with the On/Off switch and nothing happens.** First check to see if the Insert is plugged in and the receptacle has power to it.

Solution: Check the fuse on the back of the control board. Replace with a 125 Volt, 5 Amp fuse.

9. **Why is my glass dirty?** Normal operation of your St. Croix Insert will produce a light build-up on the glass that wipes off with a dry paper towel. However extended burning on the low setting only will produce a tan color. These types of build-up on the glass are normal. A heavy black build-up on the glass could indicate a problem.

Solution: Adjust the combustion air damper or combustion fan voltage. If this doesn't seem to help, make sure the clean out cover plates are installed in the Insert. It also could be an indication that the Insert is getting plugged and needs a good cleaning. Refer to the section in the manual that covers the Daily, Periodic and Yearly Maintenance of the Insert.

8. Are there any adjustments that can be made, through the control board, to the amount of fuel that is fed into the burnpot?

Answer: There are several ways to adjust the amount of fuel that is fed into the burnpot. The feedrates can be fine-tuned while the Insert is in operation by **pressing and holding** the “Auger Feed” button down and then **either** pressing the “Heat Level High” button to advance the feedrate higher, **or** pressing the “Heat Level Low” button to decrease the feedrate.

There are 5 levels on the control board and they are indicated by a single flash of the LED’s. The default setting is the center LED. This gives 2 adjustments increasing the feedrate (LED’s 4 & 5) and 2 adjustments decreasing the feedrates. (LED’s 1 & 2) The ON time is **increased or decreased** .25 seconds with each adjustment.

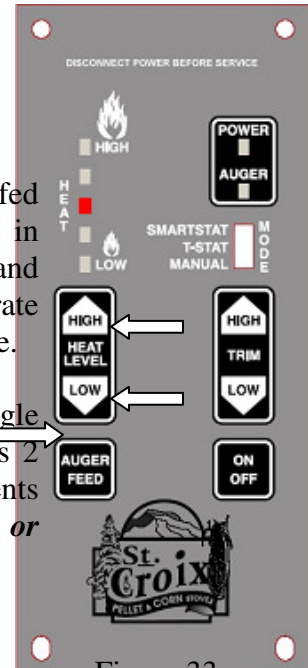

Figure 33

9. Are there any adjustments that can be made, through the control board, to the Combustion Fan voltages to help adjust the draft?

Answer: The Draft can be adjusted in a similar fashion as mentioned in the previous example.

The Fan voltages can be fine-tuned while the Insert is in operation by **pressing and holding** the “Auger Feed” button down and then **either** pressing the “Trim High” button to advance the voltages higher, **or** pressing the “Trim Low” button to decrease the fan voltages.

There are 5 levels on the control board and they are indicated by single flash of the LED’s. The default setting is the center LED. This gives 2 adjustments increasing the voltage (LED’s 4 & 5) and 2 adjustments decreasing the voltage. (LED’s 1 & 2) The voltage is **increased or decreased** 2.5 volts with each adjustment.

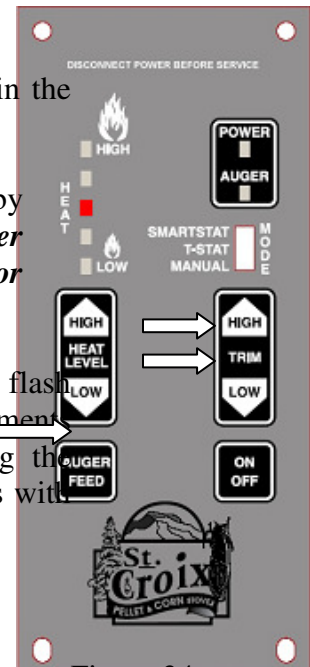

Figure 34

10. Are there Cycle Time adjustments on the Control Board for different types of fuel?

Answer: There are 4 individual programs on the control board, each with a different Cycle time. The Ashby-P only uses Programs 3 and 4

Your Ashby-P has been factory set to Program 3. When reprogramming the control board, you will see LED light flash, as shown in the figure to the right. The LED lights flash in the following manner:

- 1 - **Program 1.** The Cycle Time is 11.5 seconds. **THIS PROGRAM IS ONLY TO BE USED WITH THE ASHBY-MF MODEL. (DO NOT USE THIS PROGRAM WITH THE ASHBY-P).**
- 2 - **Program 2.** The Cycle Time is 13 seconds. **THIS PROGRAM IS ONLY TO BE USED WITH THE ASHBY-MF MODEL. (DO NOT USE THIS PROGRAM WITH THE ASHBY-P).**
- 3 - **Program 3.** The Cycle Time is 11.5 seconds. **THIS IS THE DEFAULT PROGRAM FOR USE WITH THE ASHBY-P.** This program is for use with **Pellets, Cherry Pits and a 50/50 Percent Mixture of Pellets & Corn (See fig. 19 on page 34).** **(DO NOT USE THIS PROGRAM WITH THE ASHBY-MF).**
- 4 - **Program 4.** The Cycle Time is 10 seconds. **This Program offers Self-Ignition and is only for units that have the Versa Grate system & Igniter installed.** This program is for use with **Cherry Pits only (See fig. 19 on page 34).** **(DO NOT USE THIS PROGRAM WITH THE ASHBY-MF).**

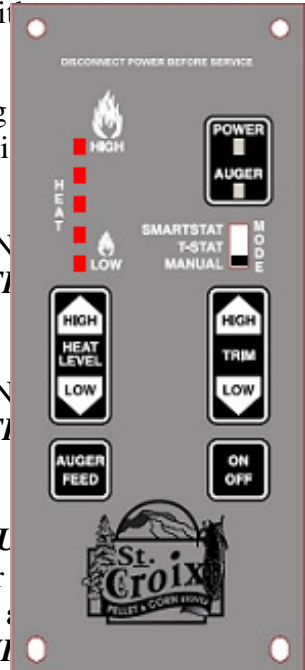

11. **How do I change to a different Program on the control board?**

First the Insert must be turned off and cooled down.

Step 1 - The Thermostat switch must be in the **Manual** position.

Step 2 – Press and hold the **Auger Feed** Button.

Step 3 – Press the **Trim High and Low** Buttons. Release all 3 buttons at the same time.

Step 4 – Observe the LED light flashing according to the Program chosen. Program 1 flashes once, Program 2 flashes twice, Program 3 flashes three times and Program 4 flashes 4 times.

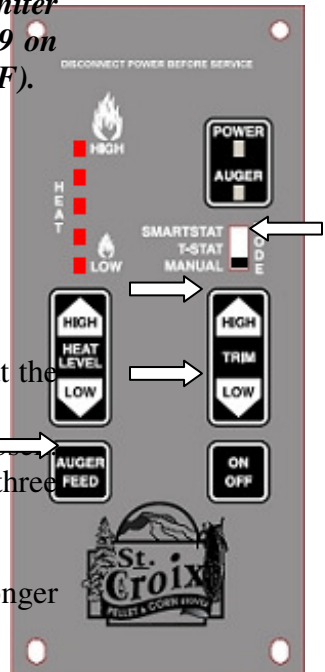
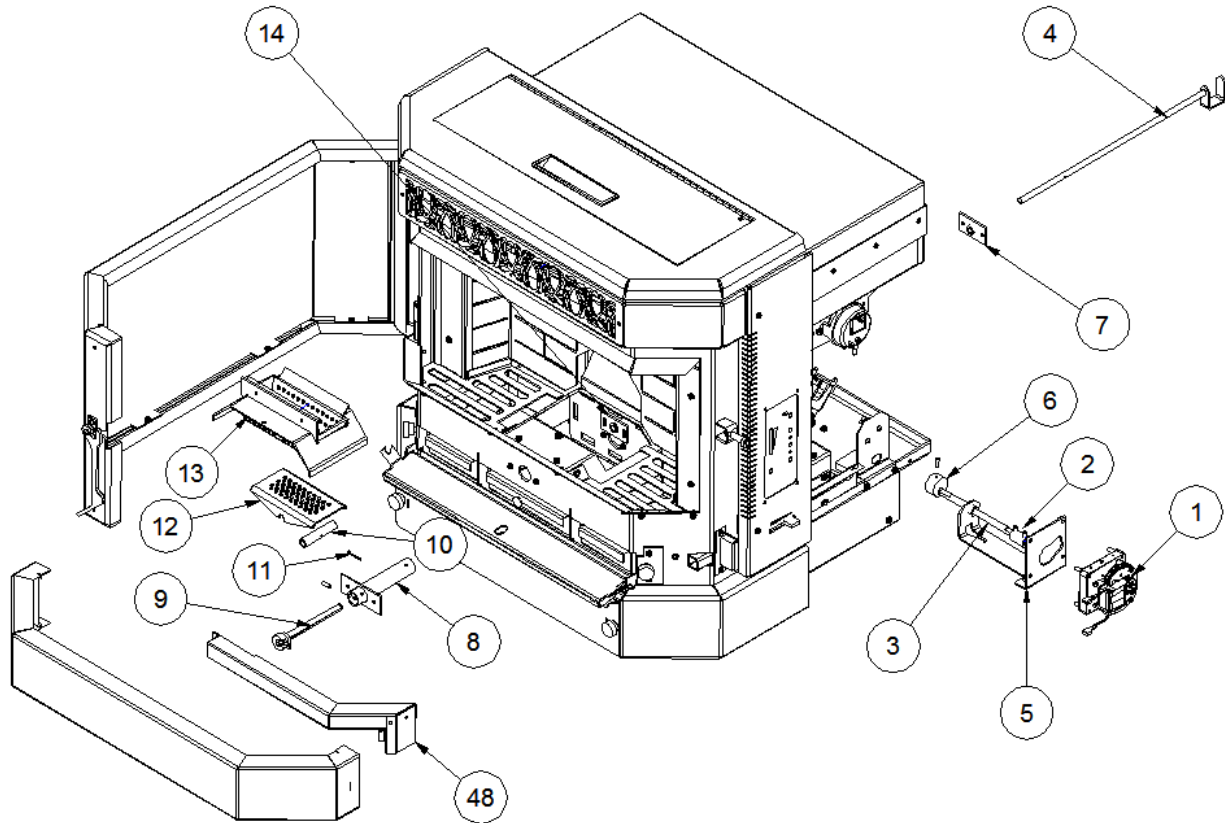

Figure 35

Changing the Cycle Time will change the BTU Input of the Insert. The longer the Cycle time the lower the BTU rating.

Parts specific to the Ashby-P with the Versa Grate System only



#	PART NUMBER	DESCRIPTION
1	80P20296-R	VERSA GRATE MOTOR
2	80P52372 -R	VERSA GRATE COLLAR W/ SETSCREWS
3	80P52376-R	CAM CONNECTOR ROD
4	80P53996-R	SHAFT/CAGE WELDMENT
5	80P52953-R	VERSA GRATE BRACKET ASSEMBLY
6	80P50560-R	CAM
7	80P52955-R	REAR BUSHING ASSEMBLY
8	80P53914-R	IGNITER TUBE WELDMENT
9	80P52727-R	IGNITER
10	80P50553-R	SPACER
11	98355A070-R	COTTER PIN
12	80P52038-R	SHAKER PLATE
13	80P53884-R	GRATE WELDMENT
14	80P52954-R	FRONT BUSHING ASSEMBLY
48	80P54123	IGNITER COVER

Ashby-P Parts

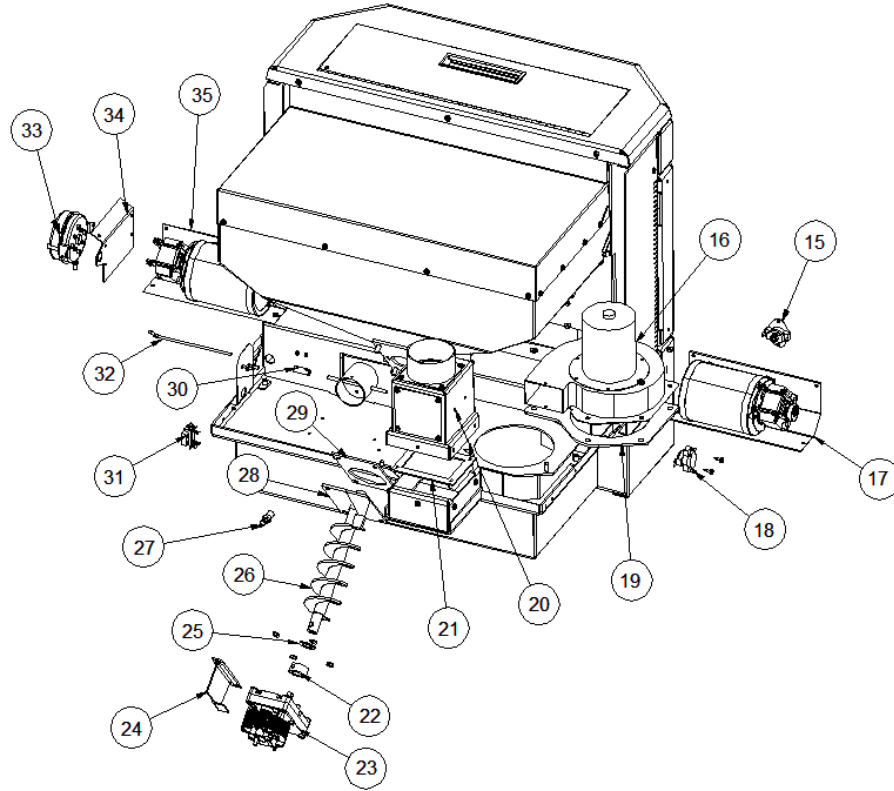

#	PART NUMBER	DESCRIPTION
15	80P52629-R	MANUAL RESET HIGH LIMIT SWITCH
16	80P30521-R	COMBUSTION FAN
17	80P30455-R	LEFT CONVECTION FAN
18	80P20038-R	PROOF OF FIRE SWITCH
19	80P30649-R	COMBUSTION FAN GASKET
20	80P53909-R	TOP/REAR VENT ADAPTER
21	80P53911-R	EXHAUST CLEANOUT SLIDE ASSEMBLY
22	80P20248-R	5/8" COLLAR W/ SETSCREW
23	80P20278-R	AUGER MOTOR
24	80P30424-R	MOTOR RETAINER BRACKET
25	80P50858-R	AUGER WASHER
26	80P53666-R	AUGER WELDMENT
27	80P30215-R	BARB FITTING
28	80P52957-R	MOTOR MOUNT BRACKET ASSEMBLY
29	80P20245-R	AUGER GASKET
30	80P30459-R	DAMPER ROD EXTENSION COLLAR
31	80P52630-R	TERMINAL BLOCK
32	80P30368-R	DAMPER INTAKE EXTENSION ROD
33	80P52628-R	VACUUM SWITCH
34	80P30457-R	VACUUM SWITCH BRACKET
35	80P30456-R	RIGHT CONVECTION FAN
36	80P53957	RIGHT SIDE PANEL WITH CLINCH STUDS
37	80P30523	CONTROL BOARD
38	80P30550	MAGNET BRACKET
39	80P30553	MAGNET

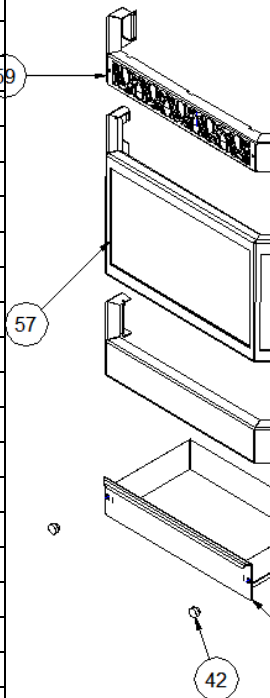

WARRANTY

#	PART NUMBER	DESCRIPTION
40	80P30412	BOLT ON LEVELING BOX
41	80P30354	ASH DOOR HINGE BRACKET - RIGHT
42	6479K53	PLASTIC KNOBS
43	80P30398	SIDE ASH PAN
44	80P30376	TRIM PLATE
45	80P30598	STEEL BRICK PANEL, LEFT
46	80P53901	ASH PAN EXTENSION WELDMENT
47	80P30462	RIGHT DECORATIVE GRILL
48	80P54123	IGNITER COVER
49	80P30646	CERAMIC WOOL GASKET
50	80P30388	TUBE SCRAPER ROD
51	80P20175	BLACK END CAP
52	80P53885	ASH DOOR
53	80P53964	LOWER PANEL ASSEMBLY
54	80P53900	ASH PAN WELDMENT
55	80P53966	COAL RAKE ROD ASSEMBLY
56	80P30376	TRIM PLATE
57	80P53725	BAY DOOR BLACK - COMPLETE
58	80P30463	LEFT DECORATIVE GRILL
59	80P53770	HOT AIR BOX W/ CLINCH STUDS
60	80P30599	STEEL BRICK PANEL, RIGHT
61	80P30606	STEEL BRICK PANEL, BACK
62	80P30362	HEAT EXCHANGE BAFFLE
63	80P30353	ASH DOOR HINGE BRACKET - LEFT
64	80P30429	SIDE PANEL - LEFT
65	80P20183	HANDLE PULL P2-54

The Ashby-P, manufactured by Even Temp, Inc., is warranted for five (5) years, to the original

owner, against defects and workmanship on all steel parts (excluding the burn grate) and two (2) year on electrical components from the date of sale to the original owner. There specifically is no warranty on the paint, glass, burn grate and all gaskets. There is no written or implied performance warranty on the Ashby, as the manufacturer has no control over the installation, daily operations, maintenance or the type of fuel burned.

This warranty will not apply if the Ashby-P has not been installed, operated and maintained in strict accordance with the manufacturer's instructions. Burning other than quality corn, wheat, rye or pellets may cause damage to the unit and could void the warranty.

The warranty does not cover damage or breakage due to misuse, improper handling or modifications.

A warranty registration card is provided. The card is to be checked and signed and returned to factory, by the owner. Appropriate information is to be noted on the card.

All claims under this warranty must be made through the dealer where the Ashby was purchased. If an inspection by the dealer indicates that a warranty claim is justified, and that all conditions of this warranty have been met, the manufacturer's total responsibilities and liabilities shall be to repair or replace, at the manufacturer's option, the defective part(s). All costs of removal, shipment to and from the dealer or manufacturer, any losses during shipment and reinstallation and any other losses due to the Ashby-P being removed shall be covered by the owner of the Insert.

NEITHER THE MANUFACTURER, NOR THE SUPPLIERS TO THE PURCHASER, ACCEPT RESPONSIBILITY, LEGAL OR OTHERWISE, FOR THE INCIDENTAL OR CONSEQUENTIAL DAMAGE TO PROPERTY OR PERSONS RESULTING FROM THE USE OF THIS PRODUCT. ANY WARRANTY IMPLIED BY LAW, INCLUDING BUT NOT LIMITED TO IMPLIED WARRANTIES OF MERCHANTABILITY OR FITNESS, SHALL BE LIMITED TO ONE (1) YEAR FROM THE DATE OF ORIGINAL PURCHASE. WHEN A CLAIM IS MADE AGAINST THE MANUFACTURER BASED ON THE BREACH OF THIS WARRANTY OR ANY OTHER TYPE OF WARRANTY EXPRESSED OR IMPLIED BY LAW, MANUFACTURER SHALL IN NO EVENT BE LIABLE FOR ANY SPECIAL, INDIRECT, CONSEQUENTIAL OR OTHER DAMAGES OF ANY NATURE WHATSOEVER IN EXCESS OF THE ORIGINAL PURCHASE PRICE OF THIS PRODUCT. ALL WARRANTIES BY MANUFACTURER ARE SET FORTH HEREIN AND NO CLAIM SHALL BE MADE AGAINST MANUFACTURER ON ANY ORAL WARRANTY OR REPRESENTATION.

Some states do not allow the exclusion or limitation of incidental or consequential damages, or limitations of implied warranties; therefore the limitations of exclusions set forth in this warranty may not apply to you. This warranty gives you specific legal rights, and you may have other rights, which vary from state to state.

Notes:

After the break in period, please note any adjustments that were made to the Feed Trim and Draft Trim on the control board in the area below. In the event of a power failure or if the units gets unplugged the trim settings will be lost.

Feed Trim: Circle one (See point 3 on page 32)

LED #1 LED #2 LED #3 LED #4 LED #5

Draft Trim: Circle one (See point 4 on page 32)

LED #1 LED #2 LED #3 LED #4 LED #5

FUEL: Circle One

PELLETS CORN WHEAT RYE CHERRY PITS DISTILLERS GRAIN

PROGRAM: Circle one (see Figure 19 on page 34)

1 2 3 4

Serial Number:

Date of Purchase:

Dealer Information: