

Owner's Manual

- November, 1999 -

- Freestanding Direct-Vent Stove
- Natural Gas or Propane
- Residential or Mobile Home

ANSI Z21.44, Z21.11.4
CAN/CGA 1-2.19-MB1, IF41, IF55, 2.17-MB1

WARNING: If the information in this manual is not followed exactly, a fire or explosion may result causing property damage, personal injury or loss of life.

- Do not store or use gasoline or other flammable vapors and liquids in the vicinity of this or any other appliance.
- **WHAT TO DO IF YOU SMELL GAS**
 - Do not try to light any appliance.
 - Do not touch any electrical switch; do not use any phone in your building.
 - Immediately call gas supplier from a neighbor's phone. Follow the gas supplier's instructions.
 - If you cannot reach your gas supplier, call the fire department.
- Installation and service must be performed by a qualified installer, service agency or the gas supplier.

Spirit DV Gas Stove

 **Travis Industries, Inc.**
10850 117th Place N.E. Kirkland, WA 98033

\$10.00

93508056



Listed

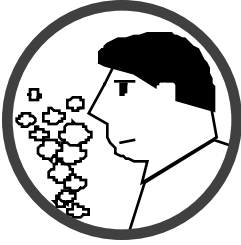

IF YOU SMELL GAS:

- * **Do not light any appliance**
- * **Extinguish any open flame**
- * **Do not touch any electrical switch or plug or unplug anything**
- * **Open windows and vacate building**
- * **Call gas supplier from neighbor's house, if not reached, call fire department**



- This unit must be installed by a qualified installer to prevent the possibility of an explosion. Your dealer will know the requirements in your area and can inform you of those people considered qualified. The room heater should be inspected before use and at least annually by a qualified service person. More frequent cleaning may be required due to excessive lint from carpeting, bedding material, etc.
- The instructions in this manual must be strictly adhered to. Do not use makeshift methods or compromise in the installation. Improper installation will void the warranty and safety listing.

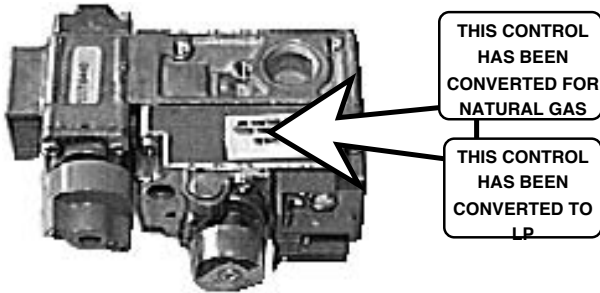

- This heater is either approved for natural gas (NG) or for propane (LP). Burning the incorrect fuel will void the warranty and safety listing and may cause an extreme safety hazard. Direct questions about the type of fuel used to your dealer. Check the label on the gas control valve.



- Contact your local building officials to obtain a permit and information on any installation restrictions or inspection requirements in your area. Notify your insurance company of this heater as well.



- If the flame becomes sooty, dark orange in color, or extremely tall, do not operate the heater. Call your dealer and arrange for proper servicing.

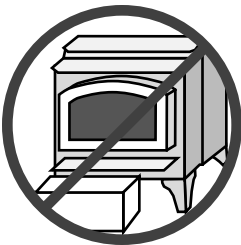

- It is imperative that control compartments, screens, or circulating air passageways of the heater be kept clean and free of obstructions. These areas provide the air necessary for safe operation.



- Do not operate the heater if it is not operating properly in any fashion or if you are uncertain. Call your dealer for a full explanation of your heater and what to expect.



- Do not store or use gasoline or other flammable liquids in the vicinity of this heater.
- Keep all furniture or other combustible items at least 36" away from the front of the heater.

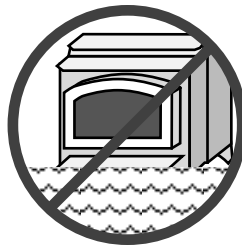

- Do not operate if any portion of the heater was submerged in water or if any corrosion occurs.

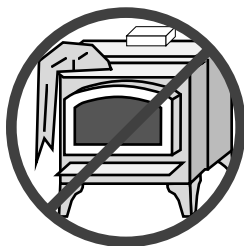

- Do not place clothing or other flammable items on or near the heater. Because this heater can be controlled by a thermostat there is a possibility of the heater turning on and igniting any items placed on or near it.

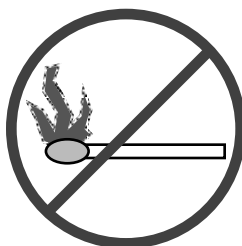

- Light the heater using the built-in piezo igniter. Do not use matches or any other external device to light your heater.

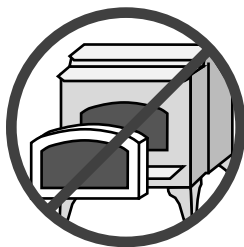

- The door (glass) should only be opened while lighting the pilot or conducting service. Damaged glass must be replaced.

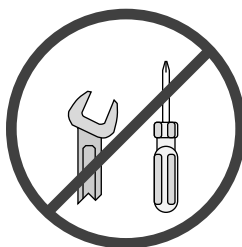

- Never remove, replace, modify or substitute any part of the heater unless instructions are given in this manual. All other work must be done by a trained technician. Don't modify or replace orifices.



- Any safety screen or guard removed for servicing must be replaced prior to operating the heater.

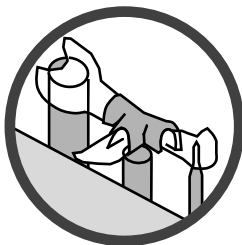

- Allow the heater to cool before carrying out any maintenance or cleaning.

- Operate the heater according to the instructions included in this manual.
- If the main burners do not start correctly turn the gas off at the gas control valve and call your dealer for service.

- The pilot flame must contact the thermopile and thermocouple (see the illustration to the left). If it does not, turn the gas control valve to "OFF" and call your dealer.

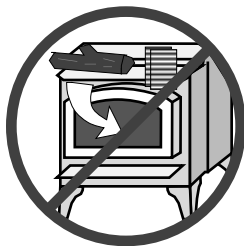

- This unit is not for use with solid fuel
- Do not place anything inside the firebox (except the included fiber logs).
- If the fiber logs become damaged, replace with Travis Industries log set.

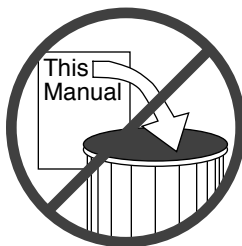

- Do not throw this manual away. This manual has important operating and maintenance instructions that you will need at a later time. Always follow the instructions in this manual.



- Do not touch the hot surfaces of the heater. Educate all children of the danger of a high-temperature heater. Young children should be supervised when they are in the same room as the heater.

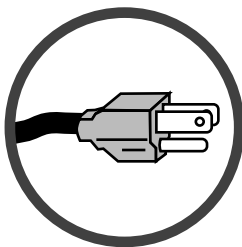

- Plug the heater into a 120V grounded electrical outlet. Do not remove the grounding plug.
- Don't route the electrical cord in front of, over, or under the heater

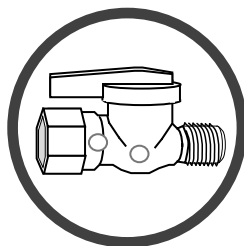

- Instruct everyone in the house how to shut gas off to the appliance and at the gas main shutoff valve. The gas main shutoff valve is usually next to the gas meter or propane tank and requires a wrench to shut off.



- **Travis Industries, Inc. grants no warranty, implied or stated, for the installation or maintenance of your heater, and assumes no responsibility of any consequential damage(s).**

General Information

Introduction & Important Information 1
 Safety Precautions..... 2

Features & Specifications

Installation Options 5
 Features..... 5
 Heating Specifications 5
 Dimensions..... 5
 Fuel..... 5
 Emissions..... 5
 Electrical Specifications 5

Stove Installation

Installation Preparation 6
 Items Required for Installation 6
 Packing Lists 6
 Order of Installation 6
 Clearances..... 6
 Stove Placement Requirements 7
 Floor Protection Requirements..... 7
 Gas Line Installation 7
 Vent Requirements..... 8
 Approved Vent Configurations..... 9
 Restrictor Position..... 9
 Elbows..... 9
 How to Measure Vent Lengths 9
 Approved Vent Config's with No Elbows
 or Two 45° Offsets (Vertical Term.) 10
 Approved Vent Config's with a
 Horizontal Termination 11
 Approved Vent Config's with a Vertical
 Termination and Two 90° Elbows..... 12
 Horizontal Vent Termination Requirements... 13
 Vertical Vent Termination Requirements 13
 Electrical Connection 13

Finalizing the Installation

1 Removing the Glass 14
 2 Installing the Logs and Coals 15
 3 Replace the Glass 15
 4 Installing the Door 16
 5 Turn on Gas, Leak Test..... 16
 6 Checking the Pilot Flame..... 17
 7 Adjusting the Air Shutter 17
 8 Checking the Flame Height 17
 9 Explaining Heater Operation to the Owner . 17

Operating Your Heater

Before You Begin..... 18
 Location of Controls..... 18
 Starting The Pilot 19
 Starting the Heater for the First Time 20
 Turning the Heater On and Off 20
 Adjusting the Flame Height..... 20
 Adjusting the Blower Speed..... 21
 Normal Operating Sounds 21

Maintaining Your Heater

Yearly Service Procedure 22

Troubleshooting

Troubleshooting Table 23
 How this Heater Works 24
 What Turns the Main Burners
 On and Off 24
 What Prevents Gas Buildup..... 24
 Why Nothing Should Be Placed
 Against the Heater 25
 Wiring Diagram 25

Warranty..... 26

Listing Information 27

Optional Equipment

Legs Installation..... 28
 Pedestal Installation..... 28
 Thermostat..... 29
 Remote Control Thermostat 30
 Propane Conversion Kit..... 32

Addendum

Altitude Considerations 34
 Class A Chimney Retrofit..... 35

Index 36

Symbols Used in this Manual

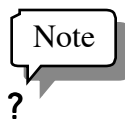
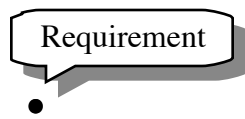

Installation Options:

- Freestanding
- Residential or Mobile Home
- Horizontal or Vertical Vent
- Class A Chimney Retrofit

Features:

- Works During Power Outages (millivolt system)
- High Efficiency; Up to 80% for Natural Gas, 82% for LP (Steady State)
- Optional Thermostat or Remote Control
- Realistic "Wood Fire" Look
- Convenient Operating Controls
- Variable-Rate Heat Output
- Quiet Blower for Effective Heat Distribution
- Low Maintenance

Heating Specifications:

	Natural Gas	LP (Propane)
Approximate Heating Capacity (in square feet)*	600 - 1600	600 - 1600
High Burn Input Rate (In BTU's)	38,500	36,500
Low Burn Input Rate (In BTU's)	18,700	18,000
Efficiency**	81 %	81.5 %
AFUE (Annual Fuel Utilization Efficiency)	72.4 %	73 %

* Heating capacity will vary with the home's floor plan and insulation, natural gas or Propane BTU rating, and outside temperature.

** Efficiency rating is a product of thermal efficiency rating determined under continuous operation independent of installed system. To measure the net BTU's, multiply the BTU input by the efficiency percentage.

Dimensions

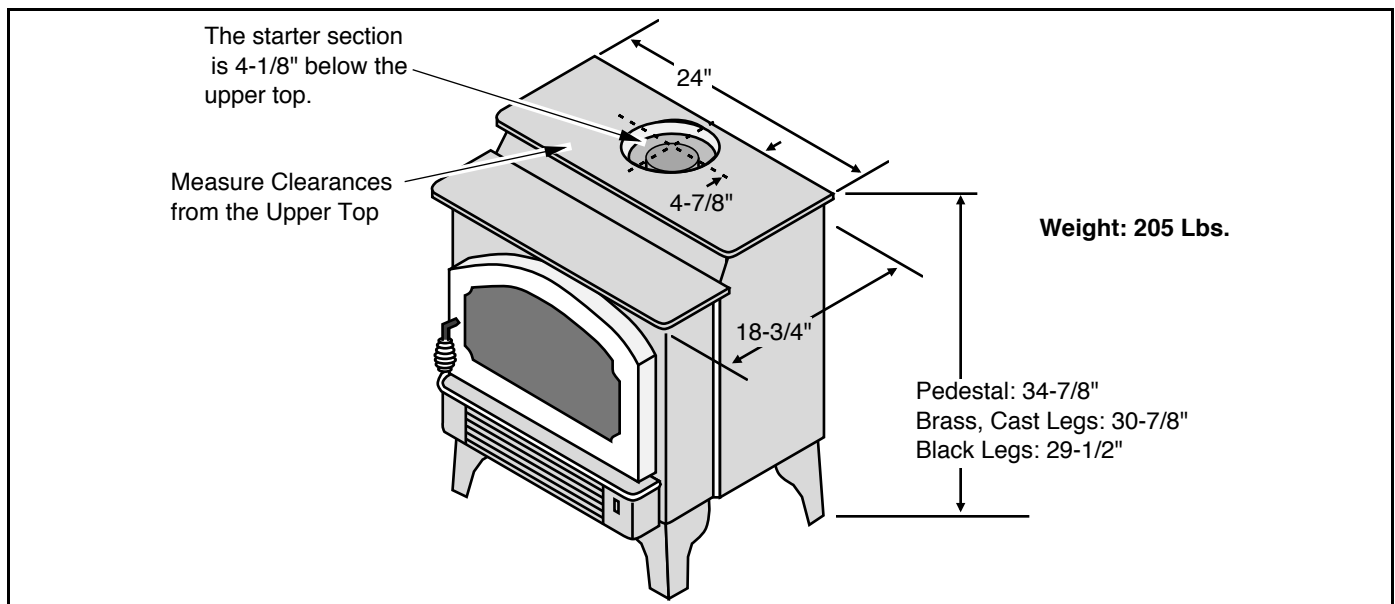

Fuel:

The heater is designed either for natural gas or for propane (but not for both). Check the sticker on the top of the gas control valve.

Emissions:

This unit has passed the ANSI emission standards for vented room heaters as tested by OMNI Environmental Services, Inc.

Electrical Specifications:

120 Volts, 1.3 Amps, 60 Hz (150 watts on high)

Installation Preparation

- ! Failure to follow all of the requirements may result in property damage, bodily injury, or even death.
- ! This appliance must be installed in accordance with all local codes, if any; if not, follow ANSI Z223.1 and NFPA 54(88).
- ! In Manufactured or Mobile Homes must confirm with: In USA, Manufactured Home Construction and Safety Standard, Title 24 CFR, Part 3280; In Canada, CSA Z240.4 and Gas-Equipped Recreational Vehicles and Mobile Housing. This appliance may be installed in Manufactured Housing only after the home is site located.
- ! This appliance is designed to operate on natural gas, or propane (LP).
- ! All exhaust gases must be vented outside the structure of the living-area. Combustion air is drawn from outside the living-area structure.
- ! Notify your insurance company before hooking up this fireplace.
- ! The requirements listed below are divided into sections. All requirements must be met simultaneously.

Items Packed with the Heater

- Lopi Spirit DV Gas Heater
- Log Set (2 Logs, 2 Twigs, Coals)
- Owner's Manual
- Door Kit (Door handle, mounting angle, T-nut)
- Propane Conversion Kit
- Gas Inlet (3/8" pipe)

Additional Items Required for Stove Installation

- Brass or Black Door Frame
- Brass, Black, or Cast Legs or Pedestal
- Simpson Duravent, Silicone (see page 8 for part #'s)

Order of Installation

- 1 If the heater is to use propane, follow the instructions on pages 32 - 38.
- 2 Attach the legs or pedestal (see page 28) and optional equipment (if applicable)
- 3 Position the heater (measure clearances from the upper top), use floor protection if needed
- 4 Connect the gas line
- 5 Connect the gas vent
- 6 Follow the instructions under "Finalizing the Installation" on pages 14 through 17.

Stove Clearances

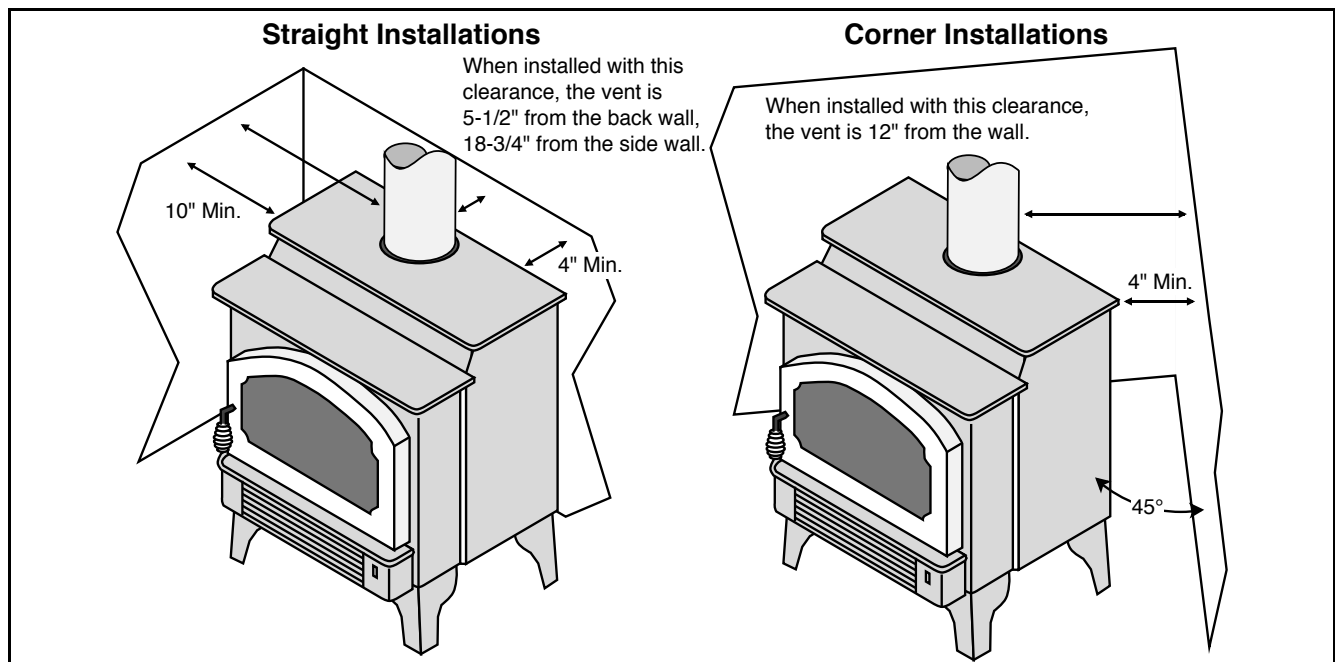

- + Clearances may be reduced by methods specified in NFPA 211, listed wall shields, pipe shields, or other means approved by local building or fire officials.

Heater Placement Requirements

- Heater must be installed on a level surface capable of supporting the heater and vent
- Due to the high temperature of the heater, it should be located out of traffic and away from furniture and draperies. Heater must be placed so no combustibles are within, or can swing within 36" of the front of the heater (e.g. drapes, doors)
- ? When placed in a location where the floor to ceiling height is under 7 feet , the installation is considered an alcove and must meet the following requirements:
 - The alcove floor to ceiling height must be at least 58" tall
 - The alcove must not be more than 48" deep (before the ceiling returns to 7 feet)
 - The alcove must be at least 44" wide
- The stove must not be placed so the vents below or above the door, along the sides of stove, or along the back of the heater can become blocked.

Floor Protection

- When the stove is installed directly on carpeting, vinyl or other combustible material other than wood flooring or a high pressure laminate wood floor, the stove must be installed on a metal or wood protection panel extending the full width and depth of the heater (Minimum 24" wide by 18-3/4" deep).

Gas Line Installation

- ! The gas line must be installed in accordance with all local codes, if any; if not, follow ANSI Z223.1 and the requirements listed below.
- ! The heater and gas control valve must be disconnected from the gas supply piping during any pressure testing of that system at test pressures in excess of 1/2 psig. For pressures under 1/2 psig, isolate the gas supply piping by closing the manual shutoff valve.
- This heater is designed for natural gas but can be converted to propane. Check the sticker on the top of the gas control valve to make sure the correct fuel is used.
- Leak test all gas line joints and the gas control valve prior to and after starting the heater.
- The gas inlet accepts a 3/8" F.P.T. Fitting
- The location of the gas inlet is shown below
- A manual shutoff valve is required for installation (it must be located within 3' of the heater)

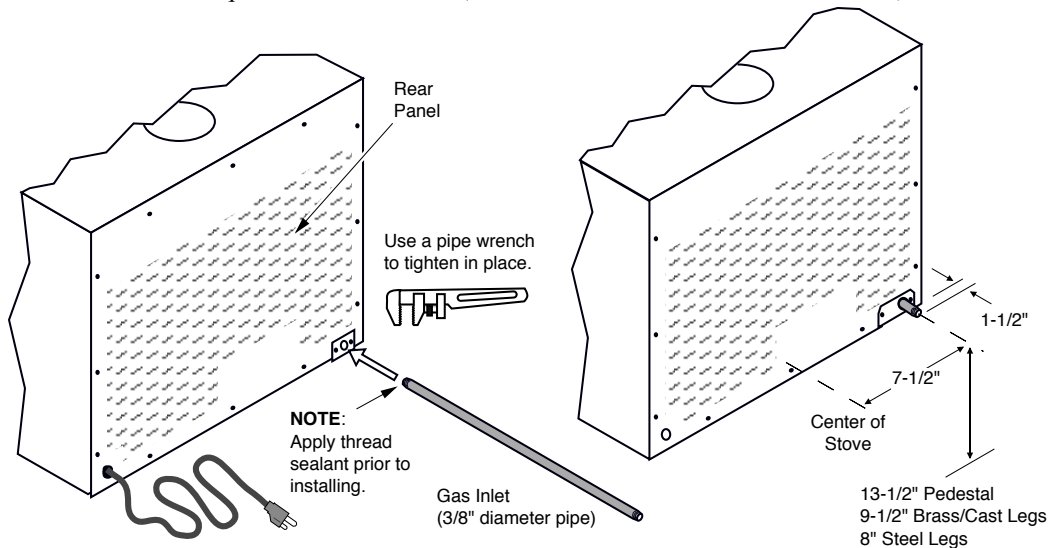

Gas Inlet Pressure

- With the heater off, the inlet pressure must meet the requirements listed in the table below
- ? If the pressure is not sufficient, make sure the piping used is large enough and the total gas load for the residence does not exceed the amount supplied.
- ? The supply regulator (the regulator that attaches directly to the residence inlet or to the propane tank) should supply gas at the suggested input pressure listed below. Contact the local gas supplier if the regulator is at an improper pressure.

	Standard Input Pressure
Natural Gas	7" W.C.
Propane	11" W.C.

Vent Requirements

- ! Always maintain the required 1" clearance (air space) to combustibles materials to prevent a fire hazard. Do not fill air spaces with insulation.
- ! The gas appliance and vent system must be vented directly to the outside of the building, and never be attached to a chimney serving a separate solid fuel or gas-burning appliance. Each direct vent gas appliance must use its own separate vent system.
- ! If the stove is installed at an altitude over 3,000 feet the flame quality will need to be carefully evaluated. See Addendum #1, "Altitude Considerations", on page 39.

- When the vent passes through a wall, a wall thimble is required. When the vent passes through a ceiling, a support box or firestop is required. When the vent passes through the roof, a roof flashing and storm collar are required. Follow the instructions and requirements provided with the vent when installing.

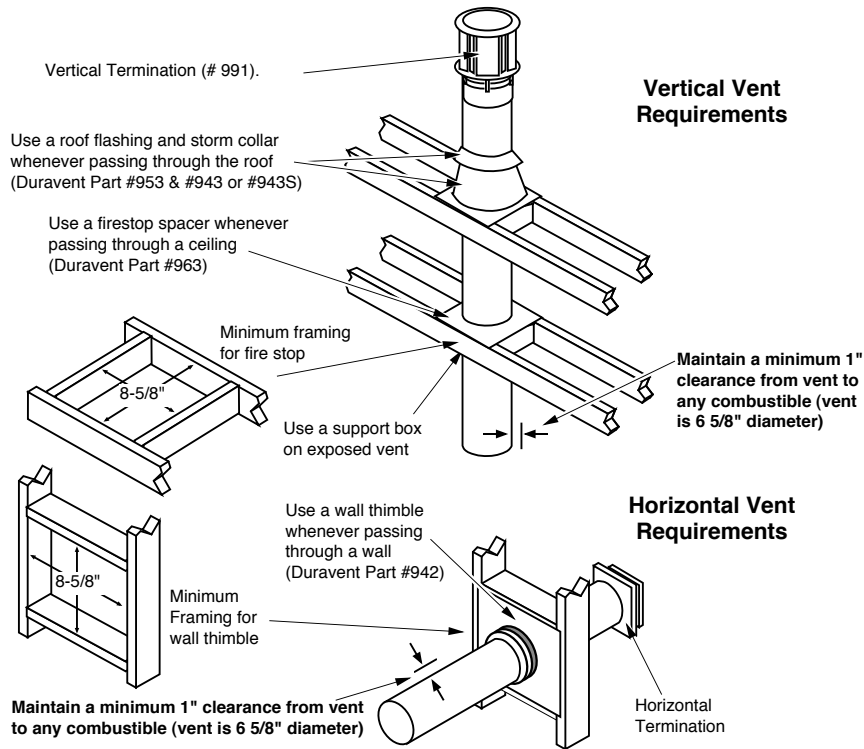

- Use Model GS Direct Vent manufactured by Simpson Dura-Vent **only** (or the Chimney Conversion Kit - see Addendum #2). Follow the installation instructions included with the vent. For the nearest Simpson Dura-Vent supplier, call (800) 835-4429. Part numbers and descriptions are listed below.

Straight Lengths		Vent Terminations	Elbows	
908B	6" Pipe Length, Black (interior)	981	990 90° Elbow	
907B	9" Pipe Length, Black (interior)		990B 90° Elbow, Black (interior)	
906	12" Pipe Length, Galvanized	982	945 45° Elbow	
906B	12" Pipe Length, Black (interior)		945B 45° Elbow, Black (interior)	
904	24" Pipe Length, Galvanized	984	Penetration, Support Parts	
904B	24" Pipe Length, Black (interior)	950	942 Wall Thimble	
903	36" Pipe Length, Galvanized	991	941 Cathedral Ceiling Support Box	
903B	36" Pipe Length, Black (interior)		943 Flashing, 0/12 to 6/12 Roof Pitch	
902	48" Pipe Length, Galvanized		943S Flashing, 7/12 to 12/12 Roof Pitch	
902B	48" Pipe Length, Black (interior)		953 Storm Collar	
911B	11" to 14 5/8" Pipe, Adjustable, Black (interior)		963 Ceiling Firestop	
			988 Wall Strap	

- Apply high-temperature silicone to the inner and outer pipe before assembling the sections (on the male, upper section). This seals the inner pipe from the outer pipe. Slide the sections together and turn 1/4 turn until the sections lock in place. Install three metal screws through each joint to lock the outer section in place (see the instructions included with the vent for further details).
- Horizontal sections require a 1/4" rise every 12" of travel
- + Exterior Vent Diameter = 6-5/8", Inner Vent Diameter = 4"

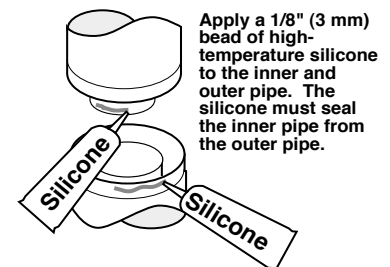

- Horizontal sections require non-combustible support every three feet (e.g.: plumbing tape)

Acceptable Vent Configurations

Restrictor Position

- A vent restrictor is built into the appliance to adjust the flow rate of exhaust gases. This ensures proper flames for the wide variety of vent configurations. The restrictor consists of a butterfly valve below the starter section of pipe and an adjustment plate with index holes used to hold the valve in a fixed position. Depending upon the vent configuration, you may be required to adjust the restrictor position. The charts for acceptable vent configurations describe which position the vent restrictor must be in.

To Adjust the Restrictor:

- Determine the correct restrictor position (see the charts under "Approved Vent Configurations" - the stock position is #1).
- Remove the screw with a 1/4" nutdriver (or screwdriver).
- Rotate the adjustment plate clockwise until the correct index hole is below the pivot point.
- Insert the screw into the correct index hole and tighten.

The eleven holes on the restrictor plate correspond to the eleven restrictor positions.

NOTE:
Position #1 is the fully open position

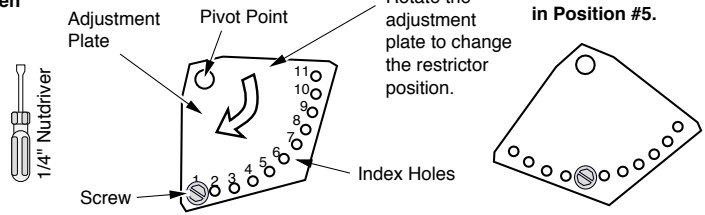
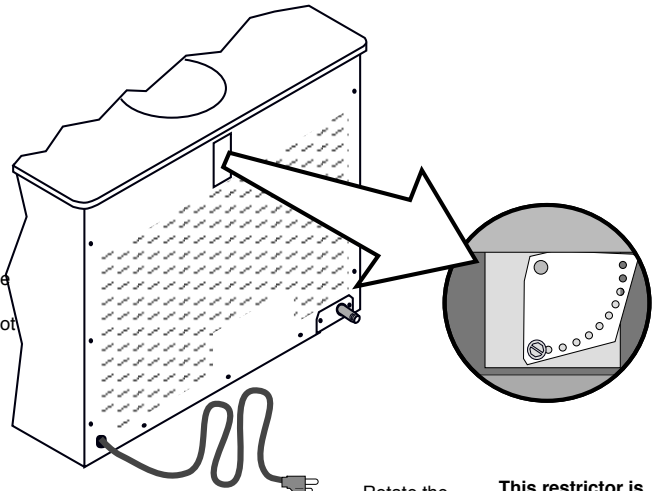

Elbows

- 2 Elbow maximum (two 45° or two 90°, not one 45° and one 90°)

Elbows add 3" to the length of the vent system.

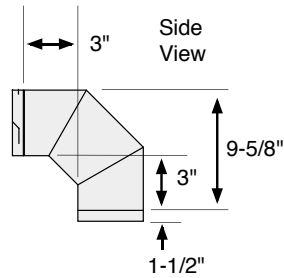

Vent sections overlap each other by 1-1/2"

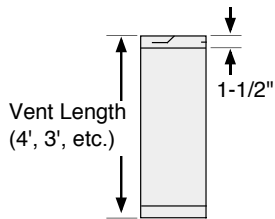

EXAMPLE:

Two 4' lengths are 7' 10-1/2" long, but when attached to the vent system add 7' 9" to the horizontal run.

Measuring Vent Lengths

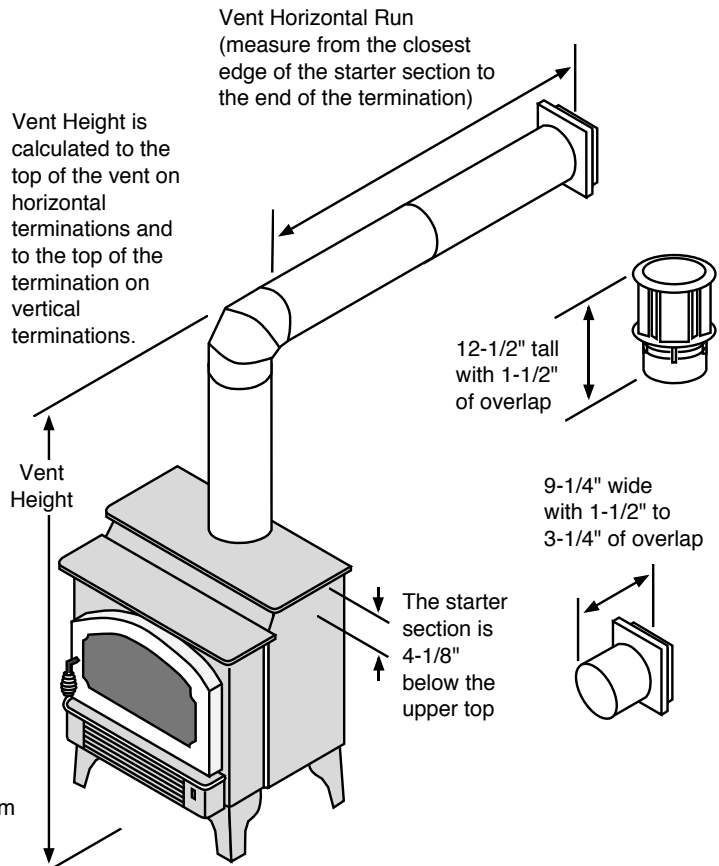

Approved Venting Configurations for Vertical Terminations with (or without) Two 45° Offsets

- 10' Minimum Height (with or without offsets)
- 33' Maximum Height
- 6' Maximum Offset
- Use restrictor position indicated by the area that your termination falls in

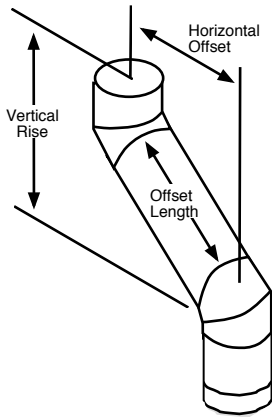

Offset Length	Hor. Offset	Vert. Rise
None	5"	1'
1' Section	1'	1' 7"
2' Section	1' 9"	2' 4"
3' Section	2' 5"	3'
4' Section	3' 2"	3' 8"
4' + 1' Section	3' 9"	4' 4"
4' + 2' Section	4' 6"	5'
4' + 3' Section	5' 2"	5' 9"
4' + 4' Section	6'	6' 9"

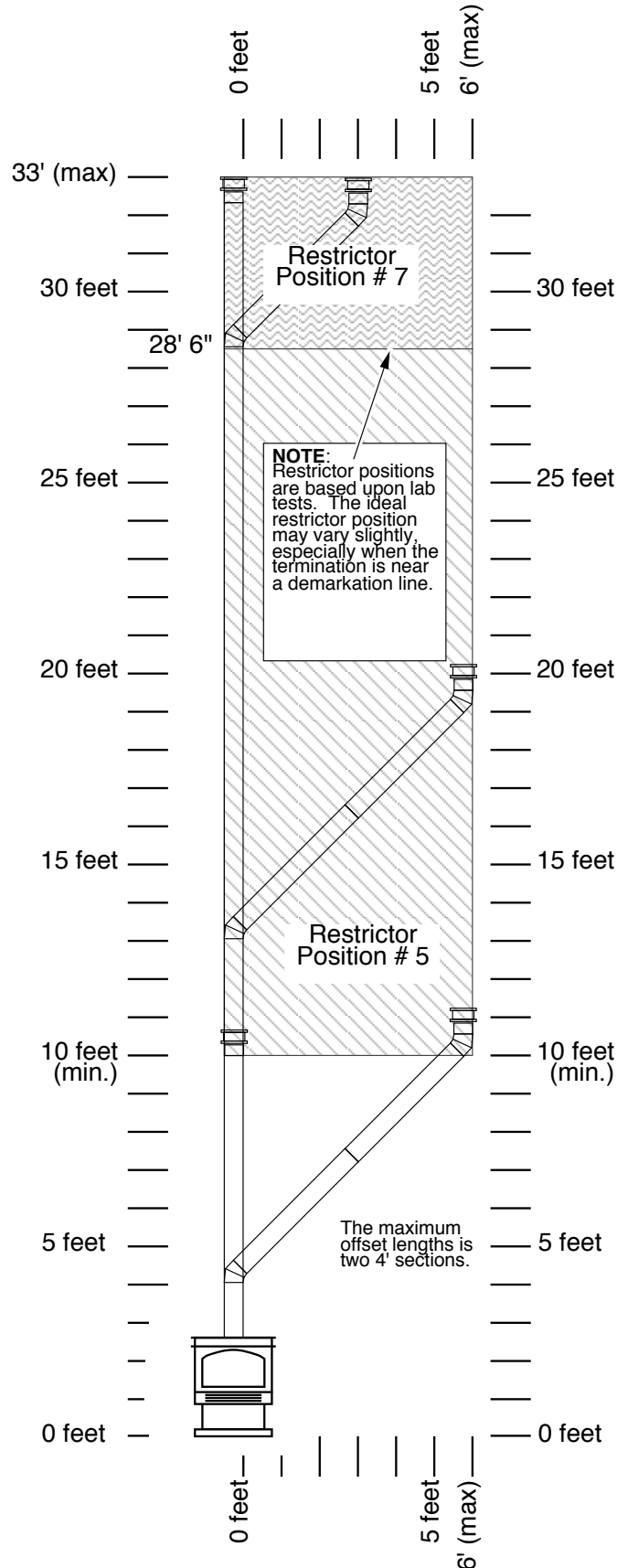

Approved Venting Configurations with a Horizontal Termination

- A Minimum of 2' rise is required directly off of the stove
- A minimum of 1' run is required
- If using a **Snorkel Termination** (14" or 36") add the snorkel height to the vertical height.

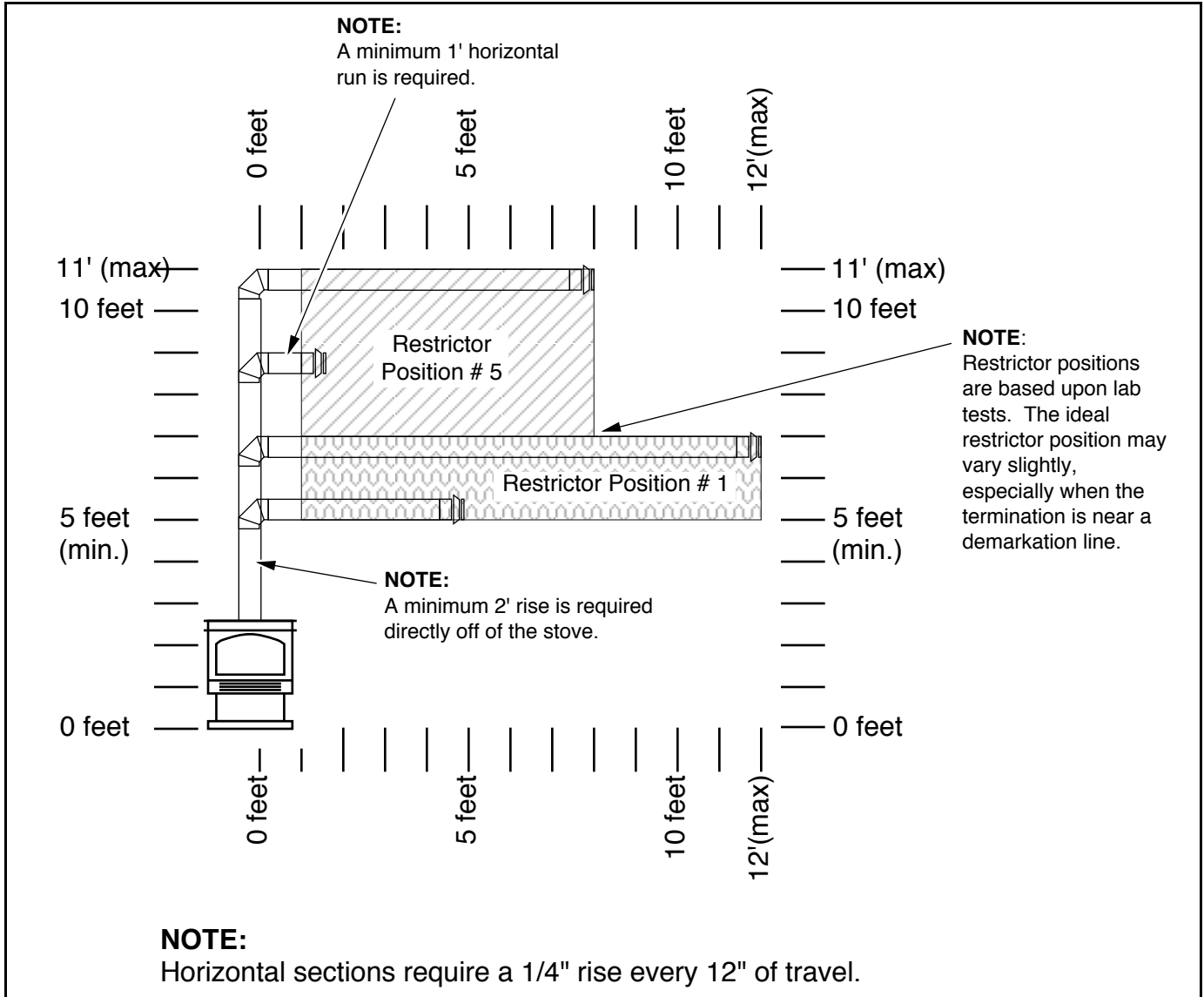

Approved Configurations with a Vertical Termination and Two 90° Elbows

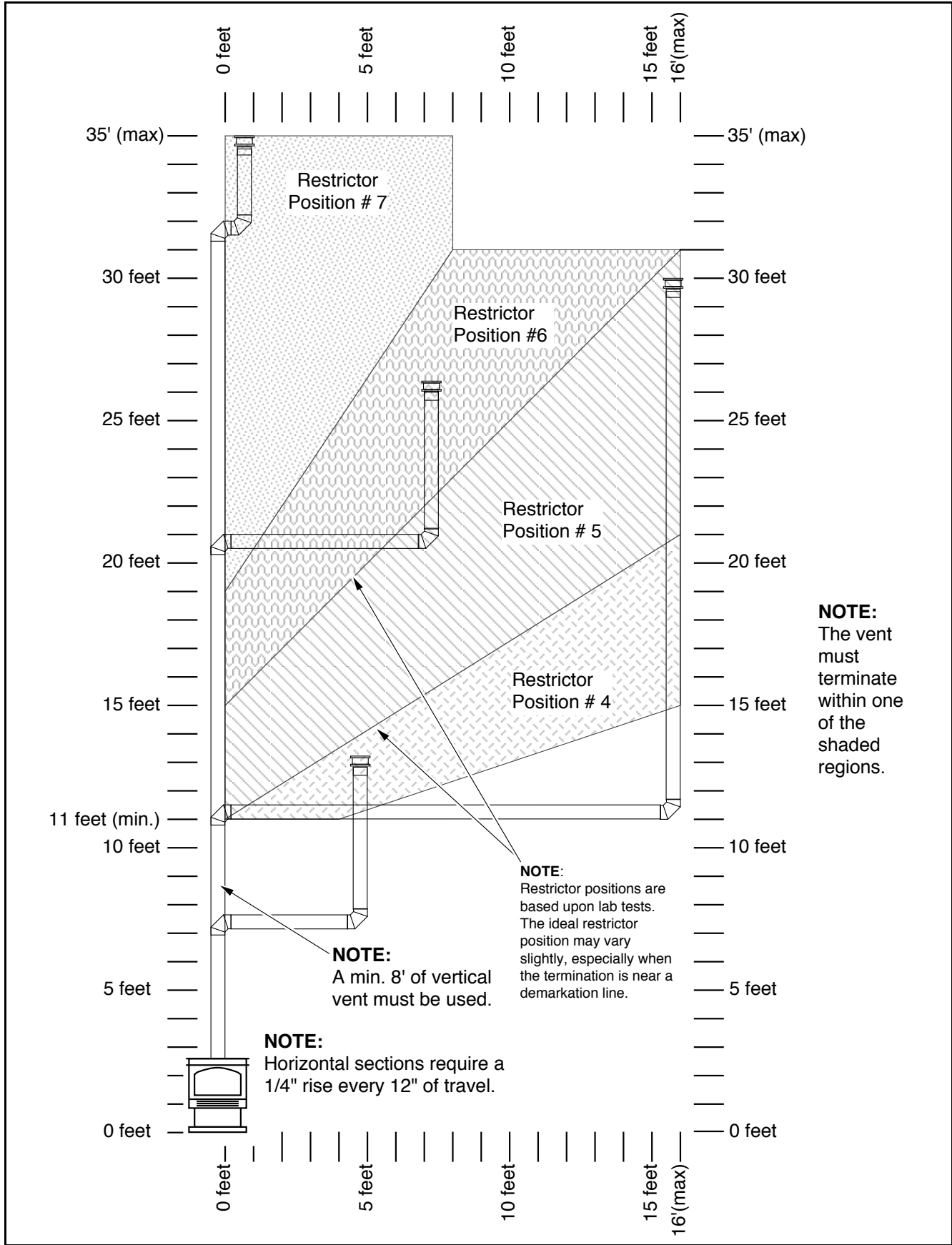

NOTE:
The vent must terminate within one of the shaded regions.

Horizontal Vent Termination Requirements (see the illustration below)

- A Minimum 9" (225 mm) clearance from any door or window
- B Minimum 12" (300 mm) above any grade, veranda, porch, deck or balcony
- C Minimum 12" (300 mm) from outside corner walls
- D Minimum 12" (300 mm) from inside corner walls
- E Minimum 11" (275 mm) clearance below unventilated soffits or roof surfaces
Minimum 18" (450 mm) clearance below ventilated soffits
Minimum 6" (150 mm) clearance from roof eaves
NOTE: Vinyl surfaces require 24" (600 mm)
- F Minimum 18" (450 mm) clearance below a veranda, porch, deck or balcony (must have two open sides)
- G Minimum 48" (1220 mm) clearance from any adjacent building
- H Minimum 84" (2130 mm) clearance above any grade when adjacent to public walkways or driveways
NOTE: may not be used over a walkway or driveway shared by an adjacent building
- I Minimum 48" (1220 mm) clearance from any mechanical air supply inlet, 72" (1820 mm) for Canada
- J Minimum 36" (910 mm) clearance above and 48" (1220 mm) below and to the sides of non-mechanical air supply inlet
- K Minimum 36" (910 mm) from the area above the meter/regulator (vent outlet)
- L Minimum 36" (910 mm) from the meter/regulator (vent outlet)

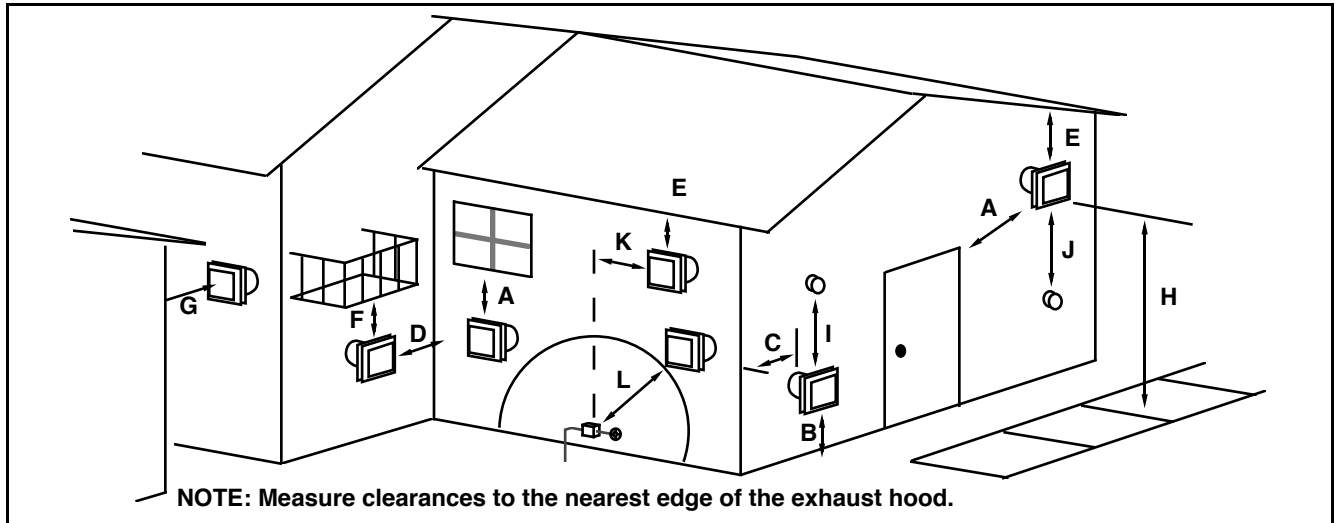
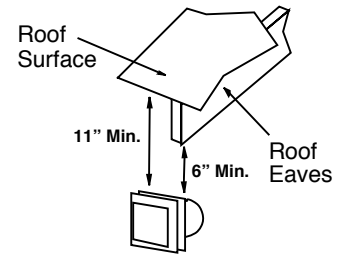

- Use the vinyl siding standoff (#950) when installing on an exterior with vinyl siding.
- Vent termination must not be located where it will become plugged by snow or other material
- These clearances meet UMC-1994 and the CNA/CGA-B149 code standards

Vertical Vent Termination Requirements (see the illustration below)

Roof Pitch	Minimum Height*
Flat to 6/12	1' (.3 M)*
6/12 to 8/12	1.5' (.45 M)*
8/12 to 9/12	2' (.6 M)
9/12 to 10/12	2.5' (.75 M)
10/12 to 11/12	3.25' (1 M)
11/12 to 12/12	4' (1.2 M)
12/12 to 14/12	5' (1.5 M)
14/12 to 16/12	6' (1.8 M)
16/12 to 18/12	7' (2.15 M)
18/12 to 20/12	7.5' (2.25 M)
20/12 or greater	8' (2.45 M)

* In Canada the vent termination must be a minimum 2' (.6 M) tall and 2' (.6 M) above any portion of the roof within 10' (3 M) of the vent.

Electrical Connection

- Plug the power cord into a grounded 120 Volt outlet (do not remove the grounding plug).

1 Remove the glass.

To remove the glass:

a

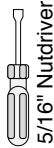

Loosen the nuts on the top and right side glass clips. Then slide the glass clips off.

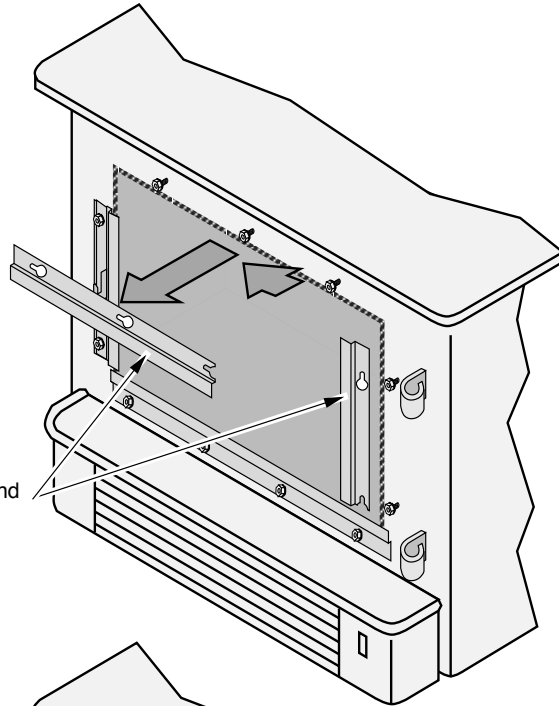

b

Loosen the nuts on the bottom and left side glass clip. Then slide the glass to the right, pivot the glass forward, and remove it from the heater.

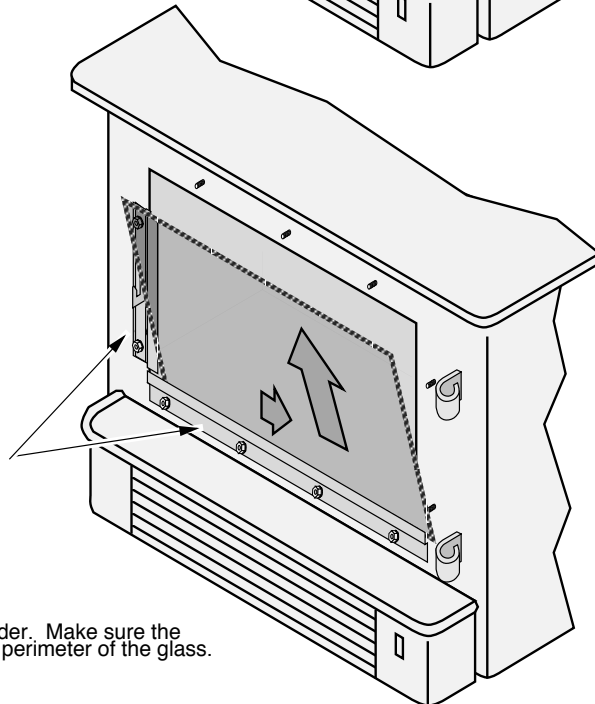

To replace the glass:

Follow the directions above in reverse order. Make sure the gasket forms an air-tight seal around the perimeter of the glass.

Cross Section of Glass Attachment

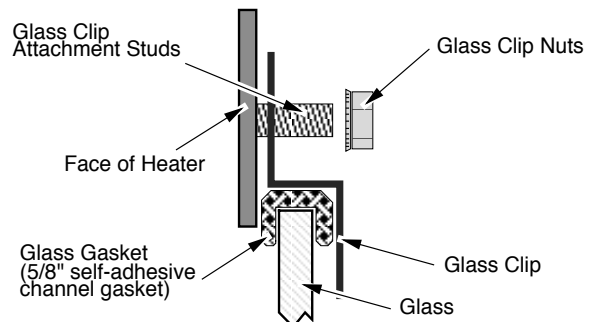

2 Install the log set and embers (see the illustration below).

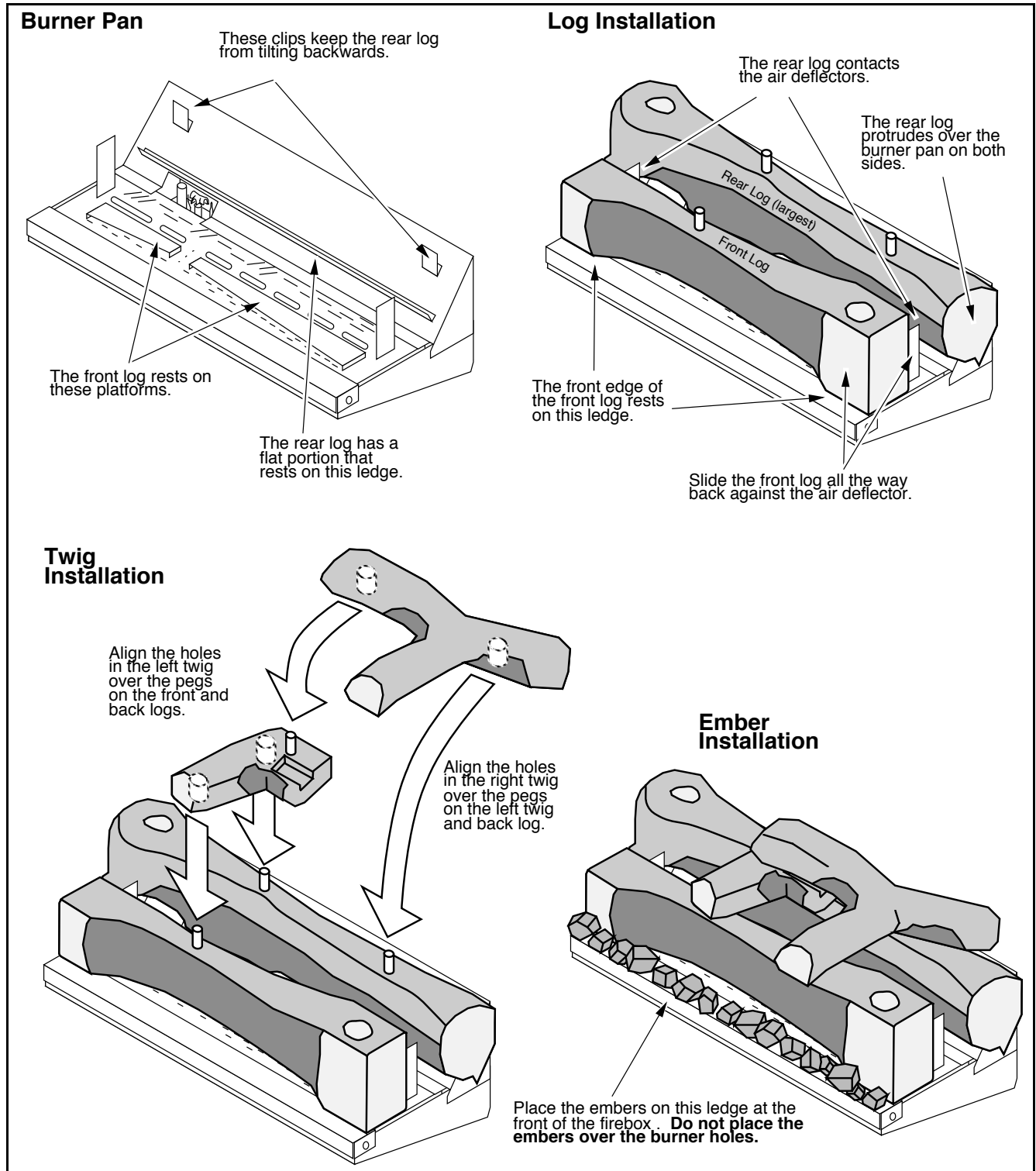

- ! We recommend you purge the gas line at this time (with the glass removed). This allows gas to be detected once it enters the firebox, ensuring gas does not build up.
- 3 Replace the glass (see the illustration on the previous page).

4 Install the door (see the illustration below).

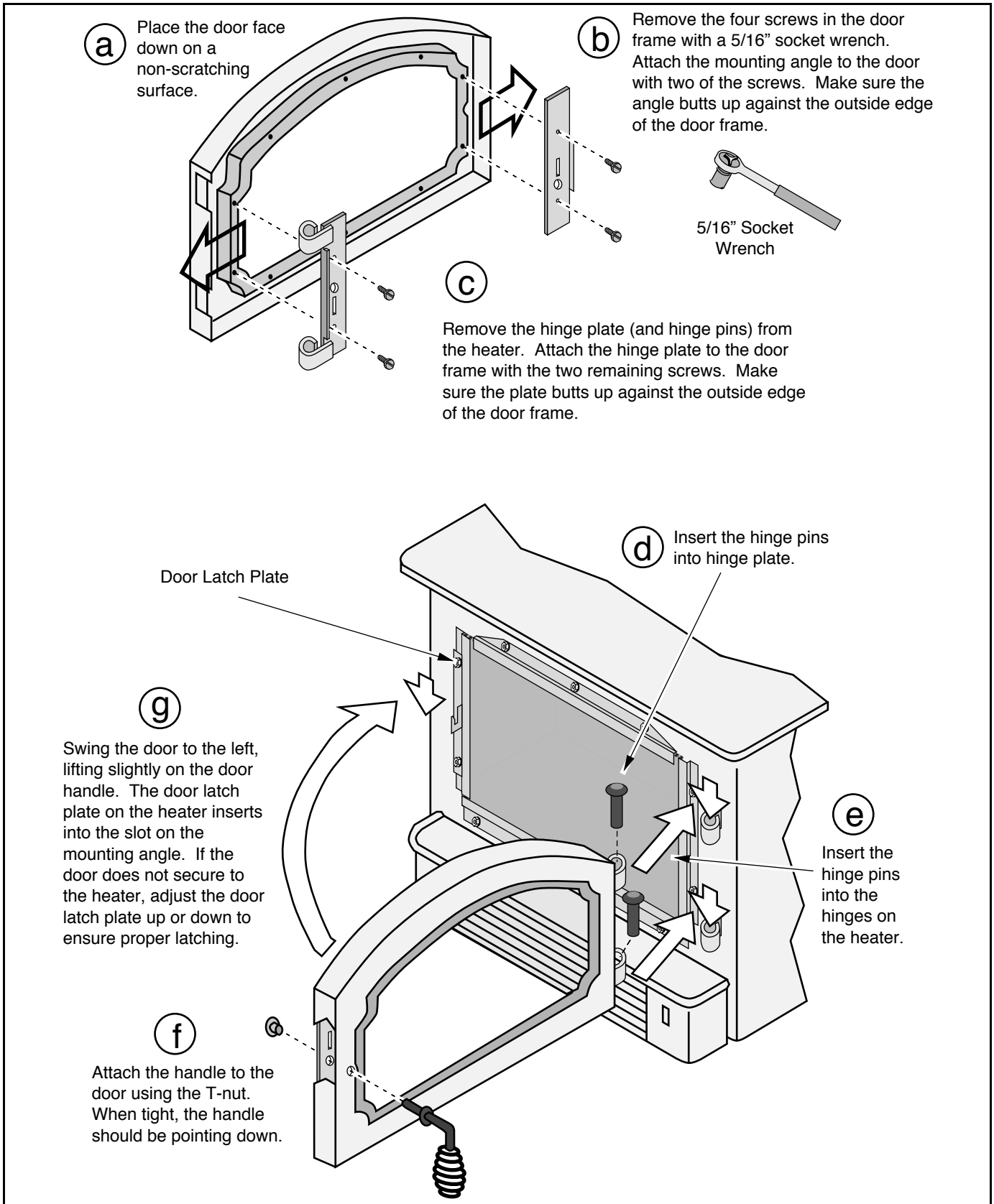

5 Turn on gas to the heater. Leak test all gas joints prior to starting the appliance. Start the pilot. Start the main burner. Leak test all gas joints again.

6 Check the pilot flame to make sure it looks like the illustration to the right. Adjust the pilot flame if necessary.

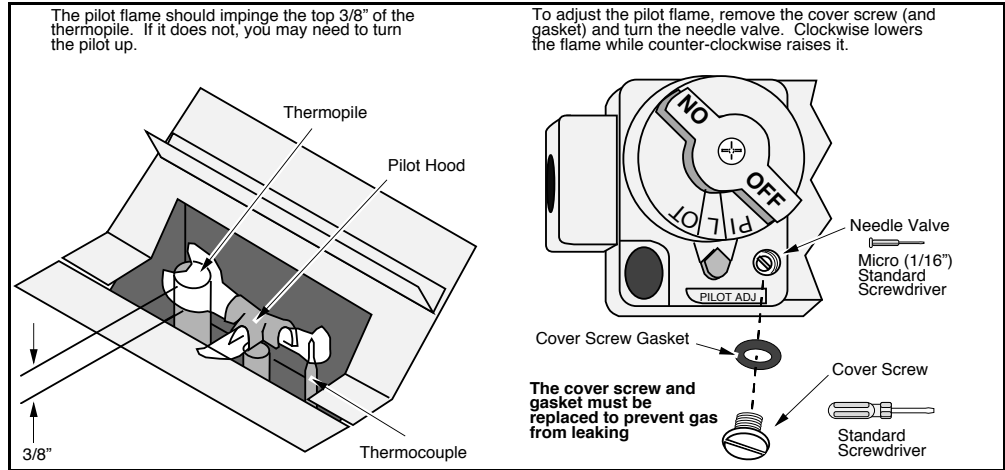

7 Let the heater burn for fifteen minutes. Adjust the air shutter, if necessary, to achieve the correct looking flame (see the illustration to the right).

- The air shutter adjusts the amount of air that mixes with the gas before it exits the burner holes. It is used to fine-tune the flame for differences in altitude and vent configuration.

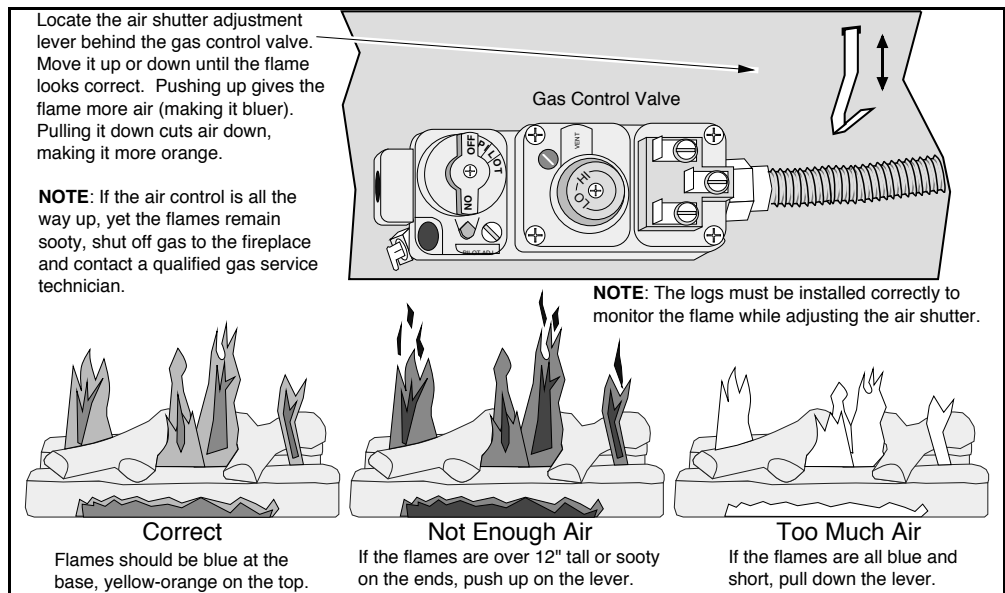

! If the air shutter is in its fully open position, yet the flames remain sooty, shut off gas to the heater and contact your dealer for a remedy.

! If the vent configuration is installed incorrectly the vent may cause the flames inside the

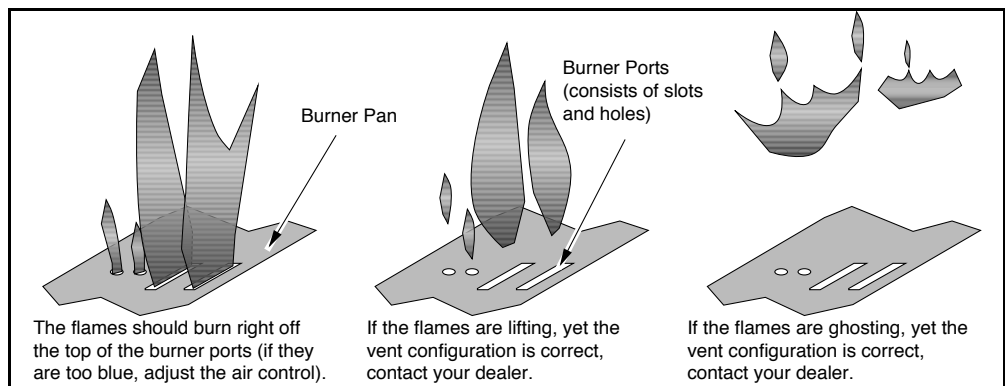

fireplace to lift or "ghost" – a dangerous situation. Inspect the flames after installation to insure proper performance. If the vent configuration is correct, yet the flames are lifting or ghosting, shut off gas to the fireplace and contact the dealer for information on remedying the problem.

8 Turn the flame adjust knob to its highest position - the flames should be between 12" and 16". Check the flame on low position. The flames should burn off of each burner hole. If the heater does not work correctly, contact your dealer for a remedy.

9 Give this manual to the home owner and fully explain the operation of this heater.

Before You Begin

! **Read this entire manual before you use your new heater (especially the section "Safety Precautions" on pages 2 & 3). Failure to follow the instructions may result in property damage, bodily injury, or even death.**

Location of Controls - See explanation below

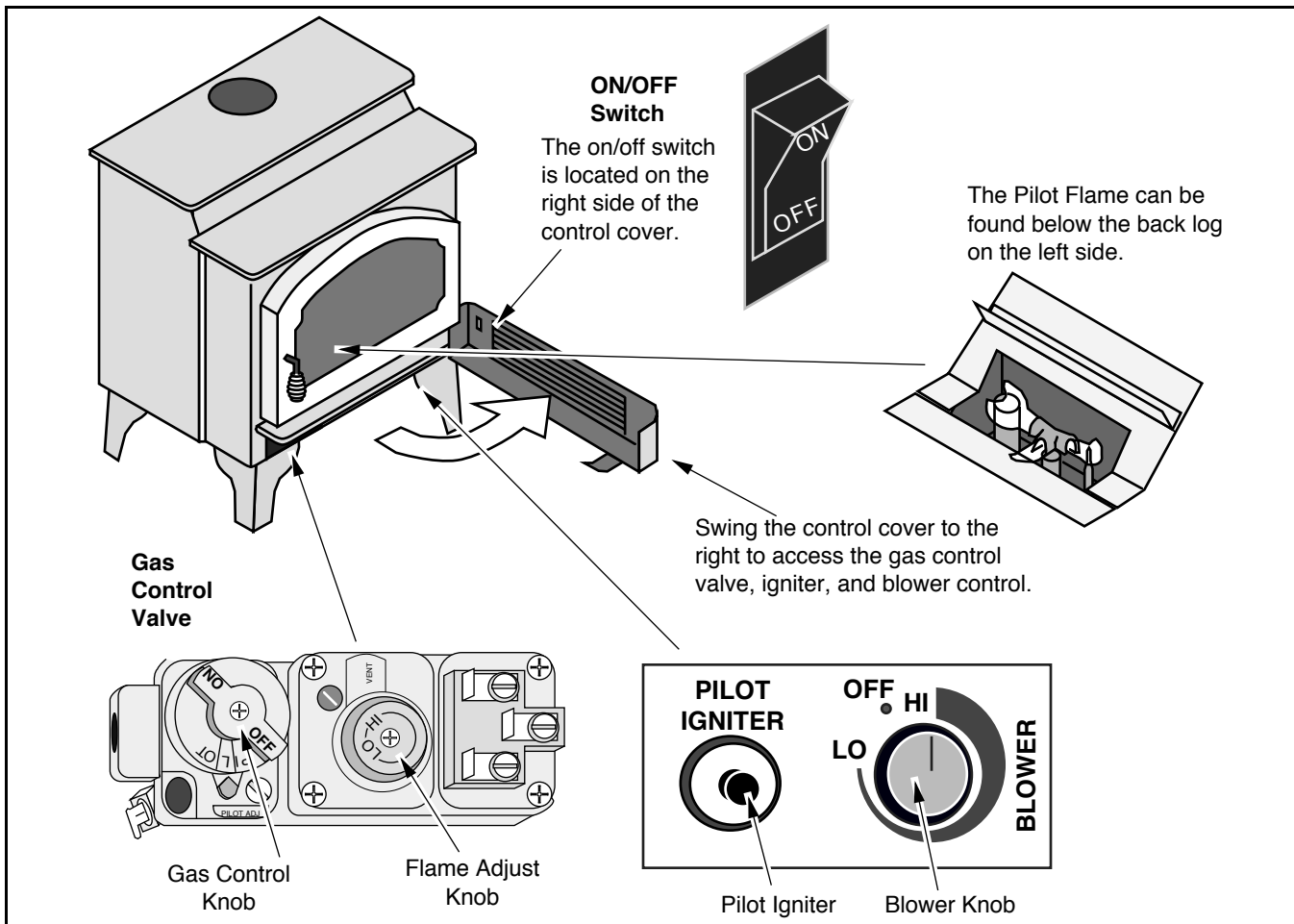

Blower Knob

This knob controls the speed of the internal convection blower that pushes the heated air into the room.

On/Off Switch

This control is used to turn the heater on and off.

Pilot Igniter

The pilot igniter is used only to start the pilot. When pressed, it sends an electrical charge to the pilot assembly. This creates a blue spark directly next to the pilot, igniting the pilot flame.

Gas Control Knob

This knob is used to control gas to the heater and for starting the pilot. There are three positions, ON, OFF, & PILOT. The pointer directly below the knob indicates the position this knob is in.

Flame Adjust Knob

This knob controls the flame height from low ("LO") to high ("HI"). The pointer to the upper right of the knob points to the position this knob is in.

? If using a remote control or thermostat, the On/Off Switch must be left "ON". Turning the On/Off Switch "OFF" will keep the heater off always.

Starting The Pilot Flame

The pilot flame is required to ignite the main burners (it also plays a safety role). It should be left on once lit. It will stay lit unless the gas control valve is turned to "OFF". However, the pilot will go out if the gas is shut off, the propane tank runs out (or low) or if the stove malfunctions. If the pilot turns off frequently, call your dealer for information. To start the pilot follow the directions below:

WARNING:

When lighting or re-lighting the pilot, the glass must be removed (see page 13).

- a Remove the glass (see page 13 for details).
- b Push the gas control knob in slightly and turn it to the "OFF" position. The knob will not turn from "ON" to "OFF" unless the knob is depressed slightly. Wait five minutes to let any gas that may have accumulated inside the firebox escape. If you smell leaking gas, follow the directions on the cover "IF YOU SMELL GAS".
- c Turn the gas control knob to the "PILOT" position and press the knob in, this will allow gas to flow to the pilot light. Press the red button on the pilot igniter repeatedly until you see the pilot light.

WARNING:

If the pilot does not light after 15 seconds, release the knob and call your dealer for service. Do not attempt to light pilot until service has been performed.

NOTE:

You may wish to remove the log set to gain a better view of the pilot.

- d Keep the gas control knob depressed for 30 seconds once it is lit.
- e Release the gas control knob. If the pilot goes out, repeat step C. If the pilot refuses to stay lit, call your dealer for service. With the pilot lit, proceed to step "f".
- f Replace the glass.
- g Turn the gas control knob counter-clockwise to "ON". The pilot is now lit and the heater can be turned on and off.

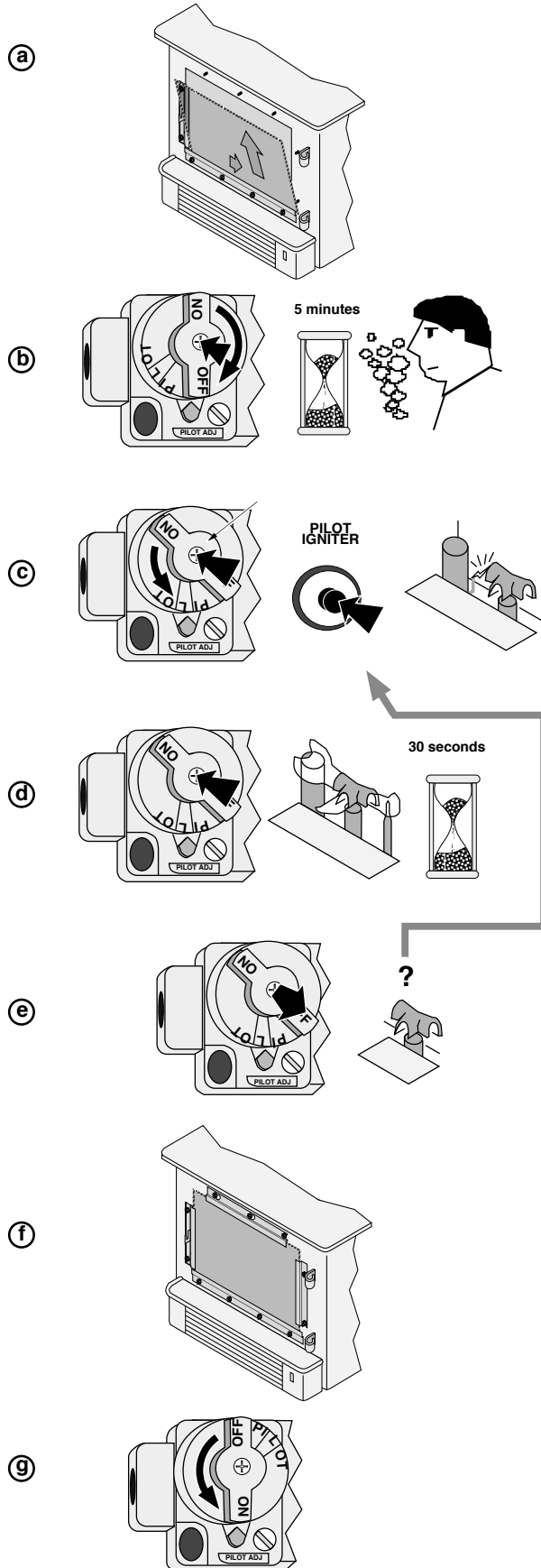

Starting the Heater for the First Time

- **Paint Curing** insures a durable finish. Start the heater and burn on low for 20 minutes. Turn off and let cool. Repeat twice to fully cure the paint.
- + **Fumes** and smoke from the paint curing and oil burning off the steel may occur the first time you start your heater. This is normal. We recommend you open windows to vent the room.
- + **Condensation** may appear on the glass each time you start the heater - this is normal.
- + **Blue Flames** will occur on the heater when it first comes on. After fifteen minutes the flames will turn a more realistic yellow and orange color.
- ? Certain installations use a remote "wall switch" to turn the heater on and off. If this is the case, leave the ON/OFF switch "ON".

Turning the Heater On and Off

After the pilot has been started...

Use this switch to turn the main burner on and off manually.

See the instructions included with the remote for details on operation.

See the instructions included with the remote for changing the battery.

For systems with thermostats, use this switch to control the temperature (right is hotter, left cooler). Some systems require the on/off switch to be on.

- ! Do not place any combustible items on top of or directly in front of the heater, even temporarily. The optional thermostat may start the heater causing a combustible item to ignite.
- ? If the heater turns on and off frequently while using the thermostat, you may want to adjust the flame height down until it produces just enough heat needed.

Adjusting the Flame Height

- + Your heater has an adjustable flame to tailor the look and heat output to your specific needs. It is adjusted by turning the middle dial on the gas control valve.

Flame Height Adjustment Knob

Index Mark

VENT

HI

LO

Turn clockwise to adjust the flame higher, counter-clockwise to lower.

Adjusting the Blower Speed

- + The blower helps transfer the heat from the heater into the room. It will not turn on until the heater is up to temperature (approximately 10 minutes after starting). See the illustration below for instructions on adjusting the blower speed.

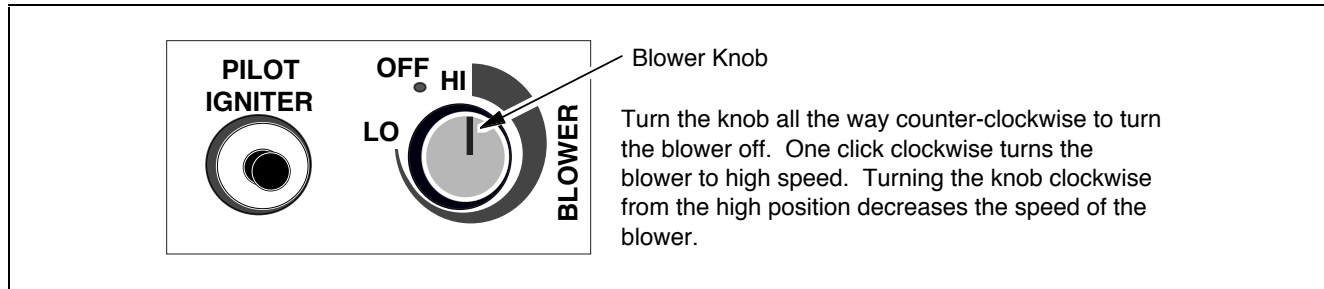

Normal Operating Sounds

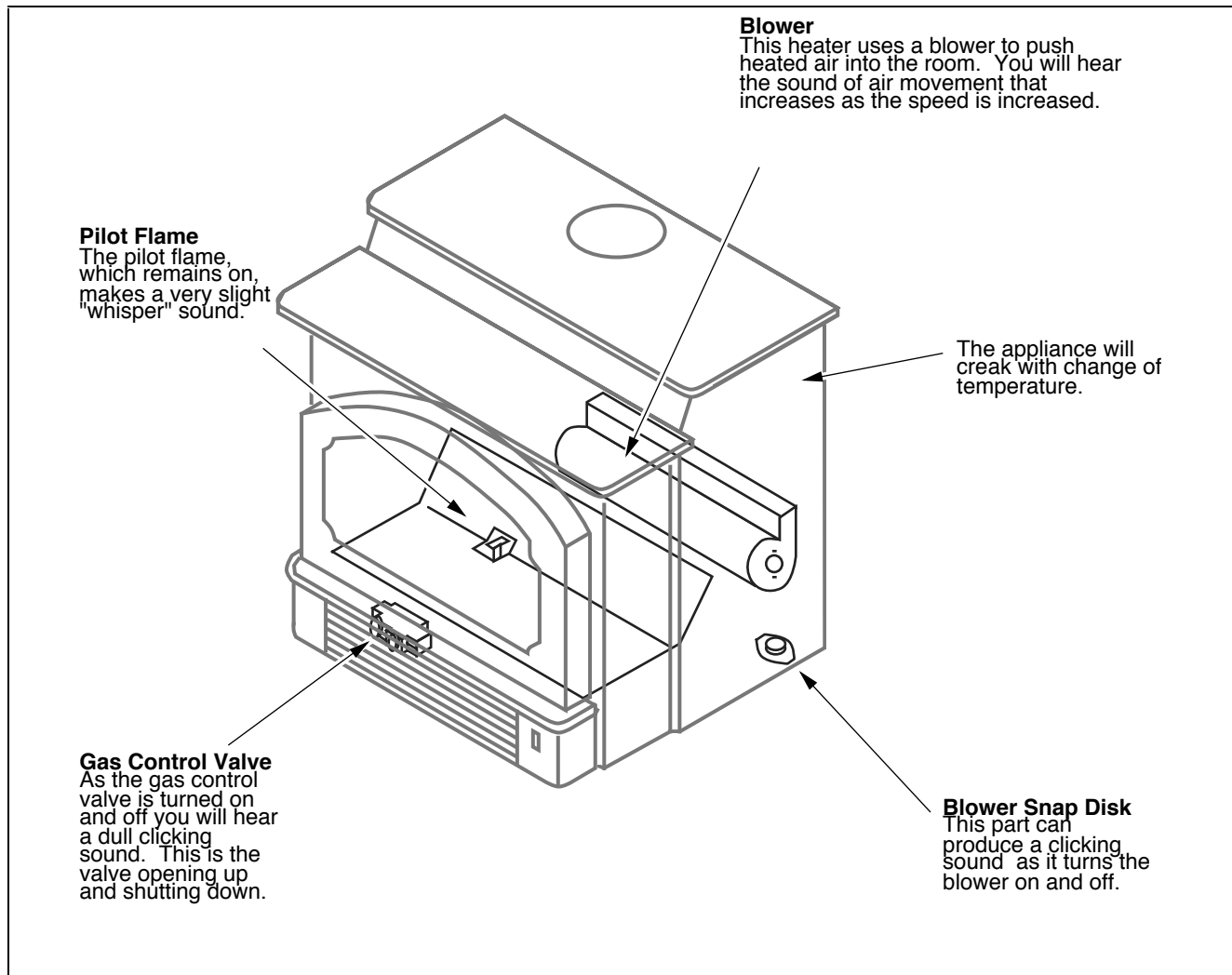

Yearly Service Procedure

- ! Failure to inspect and maintain the heater may lead to improper combustion and a potentially dangerous situation. We recommend the following procedures be done by a qualified technician.
- 1 Check the pilot flame (see illustration below). If not correct, contact your dealer for service.
- 2 Shut off gas to the heater by turning the gas control knob to "OFF" (see step A under "Starting the Pilot" on page 19). Let the heater cool for 15 minutes. Open the door by lifting on the handle. Swing the door open and lift it off its hinges (see page 16). Remove the glass (see page 15)
- 3 Remove the log set (see page 15). If any log is cracked or deteriorated, replace it when re-installing. Check the logs for sooting. A small amount of soot along the bottom of the logs is normal. If excessive sooting is found, the heater will require adjustment. Contact your dealer.
- 4 Clean the burner pan (especially in the burner holes and slots) and inspect the following:
 - Check for burner pan holes that are cracked, severely warped, or corroded.
 - Make sure the burner pan assembly fits flat against the floor of the firebox.
 - Check the firebox and area around the pilot to make sure there is no warping or damage.
 If any problem is found, discontinue use and contact your dealer for service.

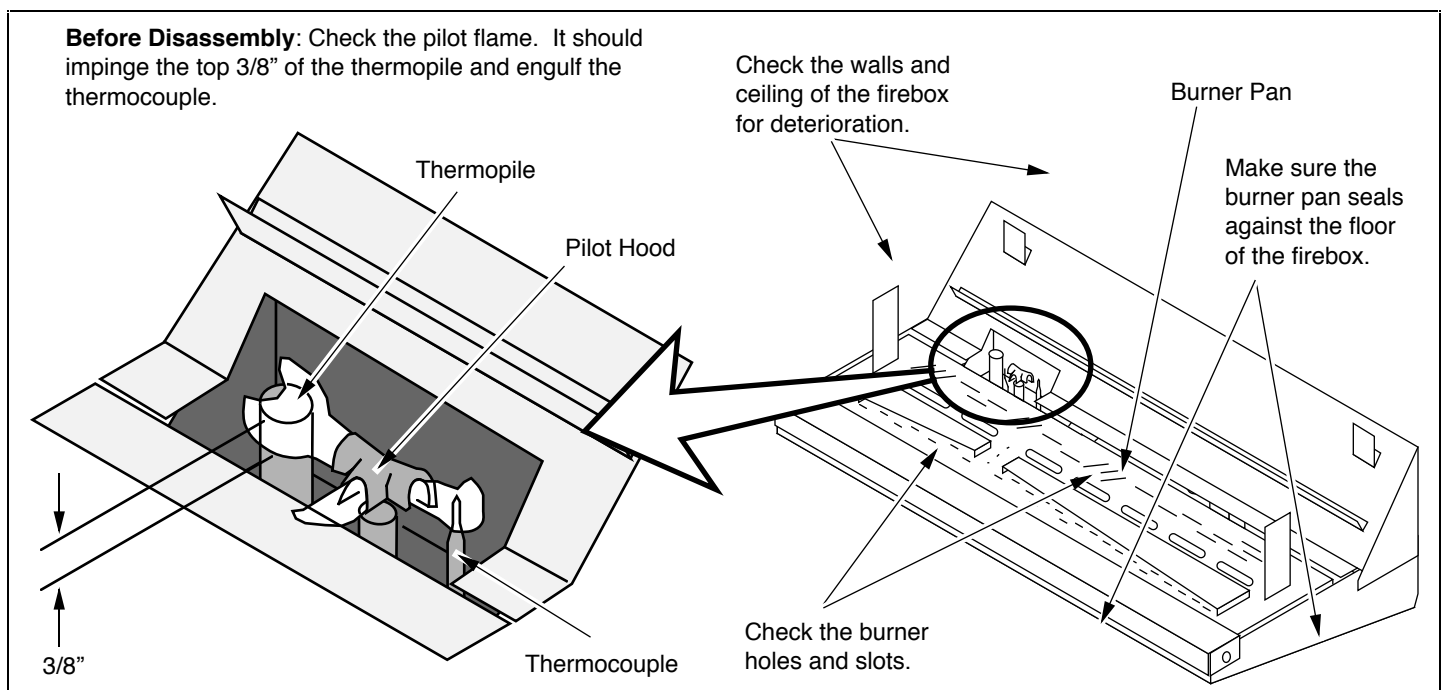

- 5 Replace the log set. Inspect the glass gasket. If it is deteriorated, replace. It may be re-attached using high-temperature gasket cement. If the glass is damaged, replace. Re-attach the glass and door.
- 6 Inspect the area behind the control cover. Check the gas control valve and all of the gas lines. If any damage is found, discontinue use and contact your dealer for service.
- 7 Start the pilot and turn on the main burner. The flames should be orange/yellow and not touch the top of the firebox. If the pilot or main burners do not burn correctly, contact your dealer for service. Monitor the blower operation.
- 8 Remove any debris or obstruction near the vent termination. Contact your dealer if any sooting or deterioration is found near the vent termination.

Problem:	Possible Cause:	Don't Call for Service Until You:
Pilot Will Not Flame	A gas shut off valve is turned off.....	Check all gas shut off valves
	The gas control knob isn't turned to "PILOT".....	See "Starting the Pilot Flame" Pg 19
	The valve control knob isn't pushed in.....	See "Starting the Pilot Flame" Pg 19
	The igniter wasn't pressed repeatedly.....	See "Starting the Pilot Flame" Pg 19
Main Burners Will Not Start	The pilot flame has gone out.....	See "Starting the Pilot Flame" Pg 19
	The gas control valve is turned to "PILOT" or "OFF".....	See "Starting the Pilot Flame" Pg 19
	The ON/OFF switch is turned to "OFF".....	Turn the ON/OFF switch to "ON"
	The remote control is not working correctly.....	See the remote control instructions
	The thermostat is disconnected or set too high.....	Set the thermostat to a lower temperature
Remote Control Does Not Work	The pilot light has gone out.....	See "Starting the Pilot Flame" Pg 19
	The gas control valve is turned to "PILOT" or "OFF".....	See "Starting the Pilot Flame" Pg 19
	The ON/OFF switch is turned to "OFF".....	Turn the ON/OFF switch to "ON"
	The remote is too far away from the stove.....	Use the remote closer to the stove
	The remote control receiver is turned "OFF".....	See the remote control instructions
	One of the two remote control batteries is dead.....	See the remote control instructions
Thermostat Does Not Work	The pilot flame has gone out.....	See "Starting the Pilot Flame" Pg 19
	The gas control valve is turned to "PILOT" or "OFF".....	See "Starting the Pilot Flame" Pg 19
	The ON/OFF switch is turned to "OFF".....	Turn the ON/OFF switch to "ON"
	The thermostat is set too high.....	Set the thermostat to a lower temperature
Blower Does Not Operate	The stove is not getting electricity.....	Check the outlet switch
	The stove is not up to temperature.....	See "Operating Your Stove"
Flames Are Too Blue	The stove has just been started.....	This is normal - see "Starting the Stove for the First Time"
Flames Are Too Short (Under 6")	The flame height may be turned too low.....	Turn the flame height to "HI" - See "Adjusting the Flame Height"

How this Heater Works

- ! This heater was designed with safety as the primary concern. Many of the components inside this heater are for safety purposes. Therefore, only certified gas service technicians should service this heater.

What Turns the Main Burners On and Off

This heater uses a millivolt system to control its operation (a millivolt is a very small amount of electricity). The thermopile and thermocouple generate electricity when heated by the pilot flame. This electricity is used to operate the gas valve. Without enough electricity, the gas valve will not turn on. That is why when starting the pilot the gas control knob has to be pressed in long enough for the thermocouple to heat up and generate enough electricity. The thermopile provides power for the ON/OFF switch, remote control, or thermostat (see the illustration below). Because the thermopile generates the electricity needed to turn the heater on and off, this heater can be operated when the power is out (although the blower will not run).

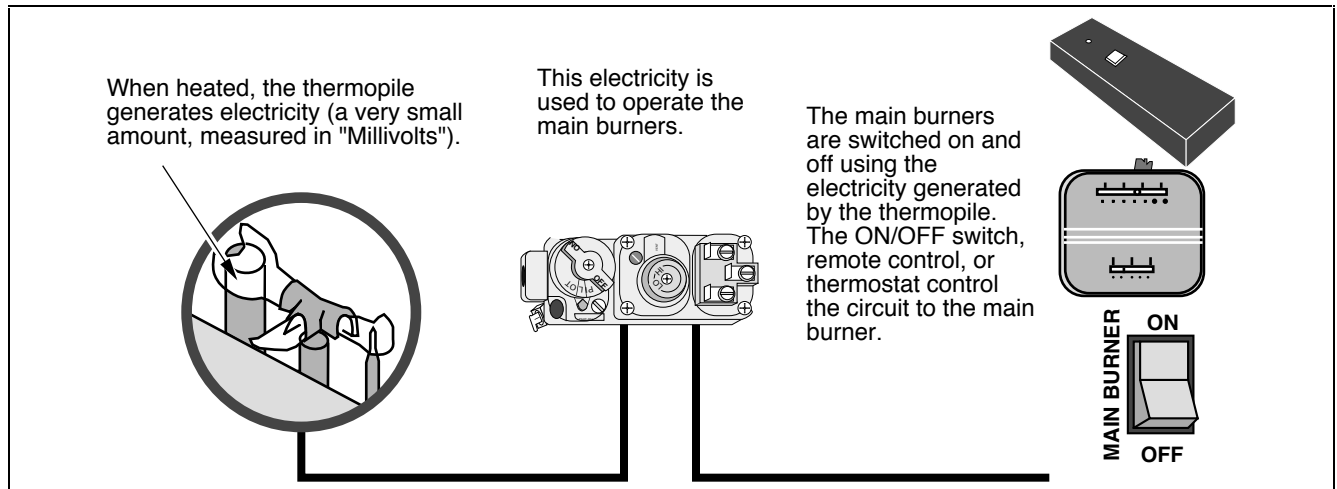

What Prevents Gas Buildup

- + This appliance utilizes a high-technology gas valve in conjunction with a pilot flame to ensure no gas builds up inside the firebox.
- + The thermocouple (next to the pilot) senses when the pilot flame is lit. If the pilot flame goes out, this thermocouple no longer generates electricity, causing the gas valve to automatically shut off all gas to the heater, preventing the pilot from spilling gas into the firebox.

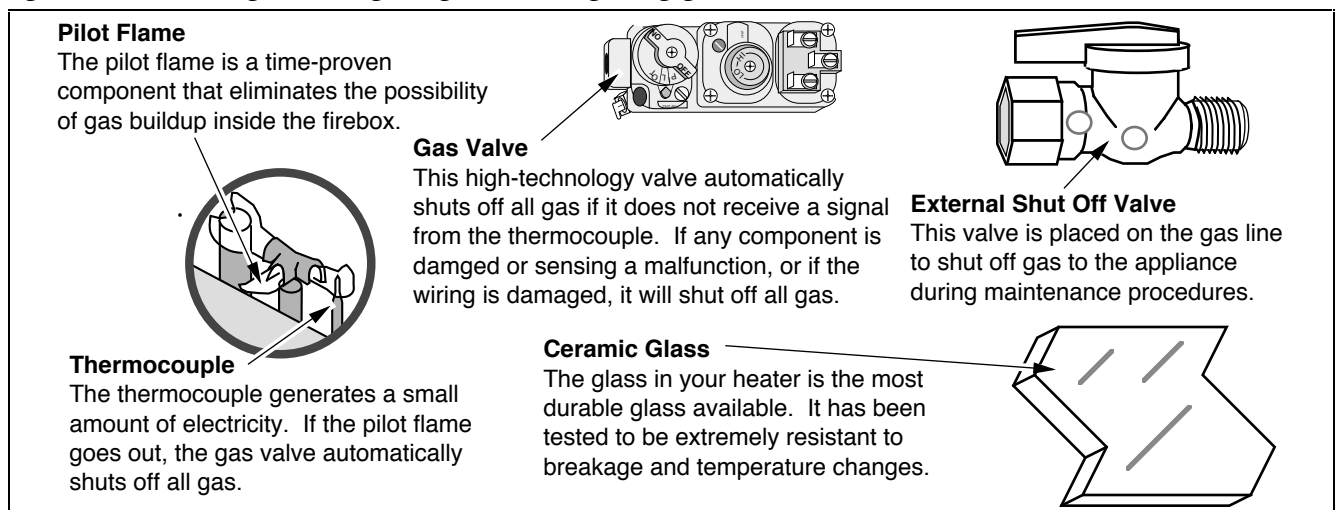

Why Nothing Should Be Placed Against the Heater

Your heater has a grill below the ashlip and air openings on along the top that must not be blocked. These openings are used to draw room air over the hottest parts of the heater and distribute the warmed air into the room. If they are blocked, the heater will not heat as well and may become too hot internally.

Wiring Diagram

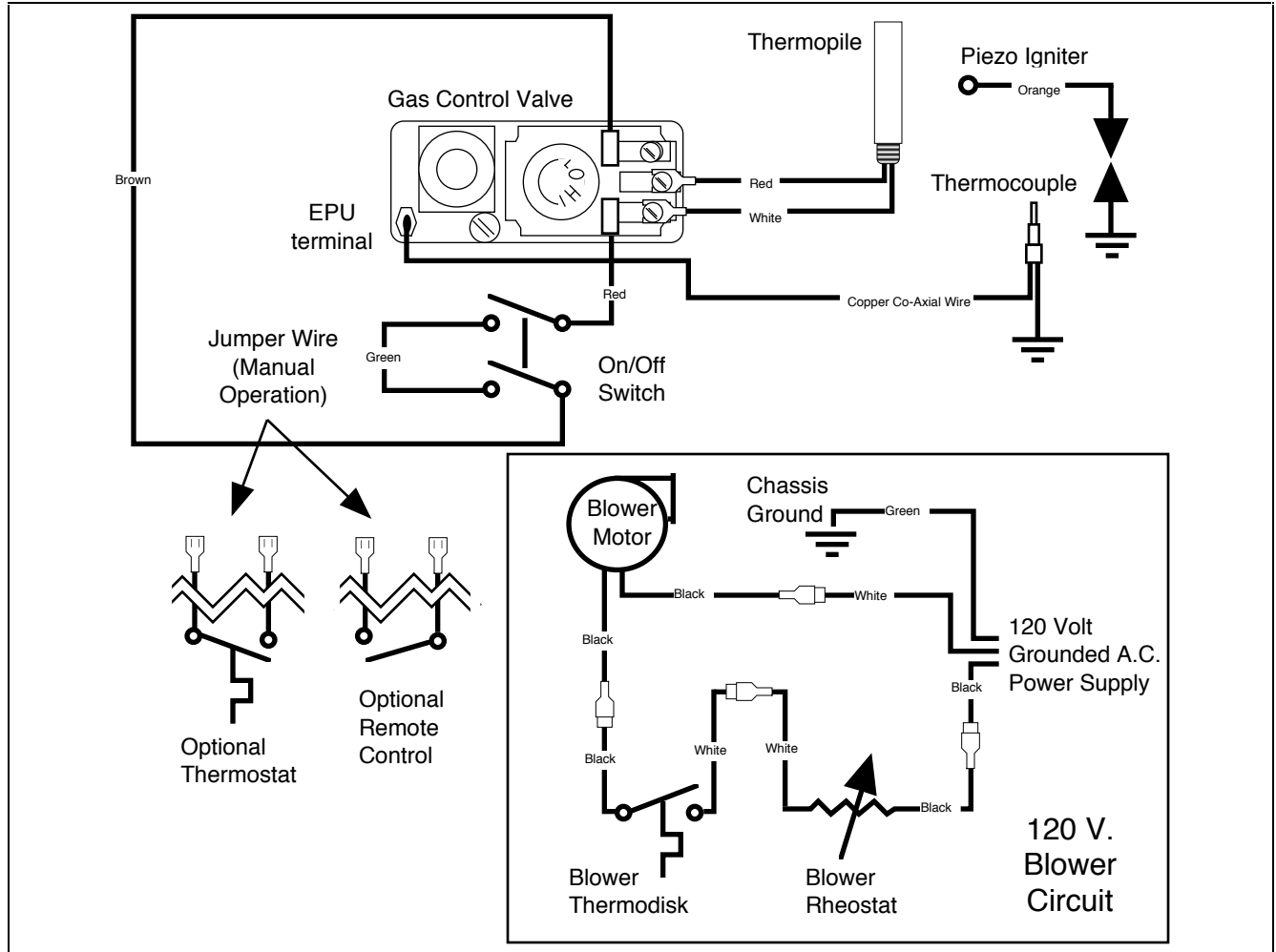

To register your TRAVIS INDUSTRIES, INC. 7 Year Warranty, complete the enclosed warranty card and mail it within **ten (10)** days of the appliance purchase date to: TRAVIS INDUSTRIES, INC., 10850 117th Place N.E., Kirkland, Washington 98033. TRAVIS INDUSTRIES, INC. warrants this gas appliance (appliance is defined as the equipment manufactured by Travis Industries, Inc.) to be defect-free in material and workmanship to the original purchaser from the date of purchase as follows:

Years 1 & 2 - COVERAGE: PARTS & LABOR

Burner Assembly:

Burner, Burner Pan, Air Shutter Assembly, Main Burner Orifice

Firebox Assembly:

Adjustable Air Restrictor, Pressure Relief Mechanisms (direct vents only), Glass Attachment Mechanism

Gas Control Assembly

Adjustable control valve, millivolt wiring and connectors (located within the metal heater structure), thermopile, thermocouple, pilot hood, orifices, pilot gas line, piezo ignitor

Ceramic Glass

Glass (breakage from thermal shock)

Ceramic Logs

Log Set, Coals, Ember Strip (Steel Fiber)

Optional Brass Door

Solid Brass Door (see "Conditions and Exclusions" # 9)

Gold Plating

Gold or Nickel Door, Optional Grill (see "Conditions & Exclusions" #9)

Electrical Assembly:

Blower, wiring harness, snap discs, rheostat speed control

Accessories

Legs, Pedestal, Panels, Cast Firebacks, Shell Assembly

Convection Heat Exchanger

Re-Installation Allowance

In cases where heater must be removed from home for repairs, a partial cost of re-installation is covered (pre-authorization required)

One-Way Freight Allowance

One-way freight allowance on pre-authorized repair done at factory is covered.

Exclusions: Paint, Gasketing

Years 3 THROUGH 5 - COVERAGE: PARTS & LABOR

Burner Assembly:

Burner, Burner Pan, Air Shutter Assembly, Main Burner Orifice

Optional Brass Door

Solid Brass Door (see "Conditions and Exclusions" # 9)

Firebox Assembly:

Adjustable Air Restrictor, Pressure Relief Mechanisms (direct vents only), Glass Attachment Mechanism

Convection Heat Exchanger

One-Way Freight Allowance

One-way freight allowance on pre-authorized repair done at factory is covered.

Exclusions: Paint, Gasketing, Electrical Assembly, Gas Control Assembly, Ceramic Glass, Ceramic Logs, Gold & Nickel Plating, Accessories, Re-Installation Allowance

Years 6 & 7 - COVERAGE: PARTS ONLY

Burner Assembly:

Burner, Burner Pan, Air Shutter Assembly, Main Burner Orifice

Firebox Assembly:

Adjustable Air Restrictor, Pressure Relief Mechanisms (direct vents only), Glass Attachment Mechanism

Optional Brass Door

Solid Brass Door (see "Conditions and Exclusions" # 9)

Exclusions: Paint, Gasketing, Electrical Assembly, Gas Control Assembly, Ceramic Glass, Ceramic Logs, Gold & Nickel Plating, Accessories, Convection Heat Exchanger, Re-Installation Allowance, One-Way Freight Allowance, Labor

CONDITIONS & EXCLUSIONS

- This new gas appliance must be installed by a qualified gas appliance technician. It must be installed, operated, and maintained at all times in accordance with the instructions in the Owner's Manual. Any alteration, willful abuse, accident, neglect, or misuse of the product shall nullify this warranty.
- This warranty is nontransferable, and is made to the ORIGINAL purchaser, provided that the purchase was made through an authorized TRAVIS dealer.
- Discoloration and some minor expansion, contraction, or movement of certain parts and resulting noise, is normal and not a defect and, therefore, not covered under warranty. The installer must ensure the appliance is burning as per the rating tag at the time of installation. Over-firing (operation above the listed BTU rate) of this appliance can cause serious damage and will nullify this warranty.
- The warranty, as outlined within this document, does not apply to the chimney components or other Non-Travis accessories used in conjunction with the installation of this product. If in doubt as to the extent of this warranty, contact your authorized TRAVIS retailer before installation.
- Travis Industries will not be responsible for inadequate performance caused by environmental conditions such as nearby trees, buildings, roof tops, wind, hills or mountains or negative pressure or other influences from mechanical systems such as furnaces, fans, clothes dryers, etc.
- This Warranty is void if:
 - The unit has been operated in atmospheres contaminated by chlorine, fluorine or other damaging chemicals.
 - The unit is subject to submersion in water or prolonged periods of dampness or condensation.
 - Any damage to the unit, combustion chamber, heat exchanger or other components due to water, or weather damage which is the result of, but not limited to, improper chimney/venting installation.
- Exclusions to this 7 Year Warranty include: injury, loss of use, damage, failure to function due to accident, negligence, misuse, improper installation, alteration or adjustment of the manufacturer's settings of components, lack of proper and regular maintenance, damage incurred while the appliance is in transit, alteration, or act of God.
- This 7 Year warranty excludes damage caused by normal wear and tear, such as paint discoloration or chipping, worn or torn gasketing, corroded or cracked logs, embers, etc. Also excluded is damage to the unit caused by abuse, improper installation, modification of the unit, drilling of the orifices, or the use of fuel other than that for which the unit is configured. Units are shipped for natural gas and must be converted to propane using the included conversion kit. Confirm fuel configuration with your installer.
- Damage to gold, nickel, or brass surfaces caused by fingerprints, scratches, melted items, or other external sources left on the surface is not covered in this warranty. Damage from the use of cleaners other than denatured alcohol on gold or nickel is not covered in this warranty. Damage from the use of abrasive cleaners on brass is not covered in this warranty.
- TRAVIS INDUSTRIES, INC. is free of liability for any damages caused by the appliance, as well as inconvenience expenses and materials. Incidental or consequential damages are not covered by this warranty. In some states, the exclusion of incidental or consequential damage may not apply.
- This warranty does not cover any loss or damage incurred by the use or removal of any component or apparatus to or from the gas appliance without the express written permission of TRAVIS INDUSTRIES, INC. and bearing a TRAVIS INDUSTRIES, INC. label of approval.
- Any statement or representation of TRAVIS products and their performance contained in TRAVIS advertising, packaging literature, or printed material is not part of this 7 year warranty.
- This warranty is automatically voided if the appliance's serial number has been removed or altered in any way. If the appliance is used for commercial purposes, it is excluded from this warranty.
- No dealer, distributor, or similar person has the authority to represent or warrant TRAVIS products beyond the terms contained within this warranty. TRAVIS INDUSTRIES, INC. assumes no liability for such warranties or representations.
- Travis Industries will not cover the cost of the removal or re-installation of hearths, facing, mantels, venting or other components.
- If for any reason any section of this warranty is declared invalid, the balance of the warranty remains in effect and all other clauses shall remain in effect.
- THIS 7 YEAR WARRANTY IS THE ONLY WARRANTY SUPPLIED BY TRAVIS INDUSTRIES, INC., THE MANUFACTURER OF THE APPLIANCE. ALL OTHER WARRANTIES, WHETHER EXPRESS OR IMPLIED, ARE HEREBY EXPRESSLY DISCLAIMED AND PURCHASER'S RECOURSE IS EXPRESSLY LIMITED TO THE WARRANTIES SET FORTH HEREIN.**

IF WARRANTY SERVICE IS NEEDED:

- If you discover a problem that you believe is covered by this warranty, you **MUST REPORT** it to your TRAVIS dealer **WITHIN 30 DAYS**, giving them proof of purchase, the purchase date, and the model name and serial number.
- Travis Industries has the option of either repairing or replacing the defective component.
- If your dealer is unable to repair your appliance's defect, he may process a warranty claim through TRAVIS INDUSTRIES, INC., including the name of the dealership where you purchased the appliance, a copy of your receipt showing the date of the appliance's purchase, and the serial number on your appliance. At that time, you may be asked to ship your appliance, freight charges prepaid, to TRAVIS INDUSTRIES, INC. TRAVIS INDUSTRIES, INC., at its option, will repair or replace, free of charge, your TRAVIS appliance if it is found to be defective in material or workmanship within the time frame stated within this 7 year warranty. TRAVIS INDUSTRIES, INC. will return your appliance, freight charges (years 1 to 5) prepaid by TRAVIS INDUSTRIES, INC., to your regional distributor, or dealership.
- Check with your dealer in advance for any costs to you, when arranging a warranty call. Dealers may require you to pay a service or trip charges for any warranty work. This charge can vary from store to store.

The safety label can be found on the rear panel. A copy is shown below.

Tested & Listed by **OMNI** Beaverton, OR, USA
 Report No. 028-S-15-5



Spirit DV
 Listed Gas-Fired Direct Vent Wall Furnace



Tested and certified by OMNI-Test, Inc. to the following standards:

USA: ANSI Z21.44-1992 Gas-Fired Gravity and Fan type Direct-Vent Wall Furnace, and applicable sections of Z21.11.1-1991 Gas-Fired Vented Room Heaters.
 CANADA: CAN 1-2.19-M81 Gas-Fired Direct-Vent Wall Furnace, CGA IR41 Direct-Vent Gas Fireplace, CGA IR55 additional requirements for Direct-Vent Fireplaces, and CAN/CGA 2.17-M91 "Gas-Fired Appliances for use at High Altitudes".

Must be installed in accordance with all local codes, if any; if not, follow ANSI Z223.1-1992 and NFPA 54(88). Installation in Manufactured or Mobile Homes must conform with: In USA, Manufactured Home Construction and Safety Standard, Title 24 CFR, Part 3280; In Canada, CSA Z240.4 and Gas-Equipped Recreational Vehicles and Mobile Housing. This model is designed to operate on natural gas, or propane (LP). This appliance uses a millivolt-type control system consisting of a gas control valve/regulator, a standing pilot burner assembly, a thermopile, a piezo ignitor, and the ON/OFF switch. THIS UNIT DOES NOT REQUIRE 110 VOLT POWER TO OPERATE. All exhaust gases must be vented outside the structure of the living-area. Combustion air is drawn from outside the living-area structure. This appliance may be installed in Manufactured Housing only after the home is site located.

WARNINGS:

Improper installation, adjustment, alteration, service or maintenance can cause injury or property damage. Refer to the information in the owner's and installation manual provided with this appliance. For assistance or additional information consult a qualified installer, service agency or the gas supplier.

Installation and repair should be performed by a qualified service person. The appliance should be inspected before use and at least annually by a qualified service person. More frequent cleaning may be required where excessive lint from material like carpeting and bedding is present. The control compartment, the burner compartment and all circulating air passageways of the appliance must be kept clean and clear at all times.

Due to high temperatures, the appliance should be located out of traffic and away from furniture and draperies.

This appliance must not be connected to a chimney flue servicing a separate solid fuel burning appliance.

This room heater is a Direct-Vent Gas-Fired appliance. DO NOT burn wood or other material in this heater.

Children and adults should be alerted to the hazards of high surface temperature and should stay away to avoid flesh burns or clothing ignition.

Young children should be carefully supervised at all times when they are in the same room as the appliance.

CAUTION:

All safety screen or guard components removed for servicing, must be replaced prior to operating the appliance.

Clothing or other flammable material should not be placed on or near the appliance.

Risk of electrical shock. Switch the household breaker off or remove fuse before servicing unit.

Use Simpson DURA-VENT direct vent system (Model GS) to vent this appliance to the exterior (direct discharge only without duct connection).

Minimum Clearances to Combustibles	L.P.		N.G.		L.P.		N.G.					
	Input Rate on "HI" (BTU/Hr)	36,500	38,500	Minimum Inlet Pressure (inches W.C.)	11"	5.5"	Input Rate on "LO" (BTU/Hr)	18,000	18,700	Maximum Inlet Pressure (inches W.C.)	13"	7"
Unit to Sidewall	10"						Main Burner Orifice (DMS)	#50	#32	Manifold Pressure on "HI" (inches W.C.)	10"	3.5"
Unit to Backwall	4"									Manifold Pressure on "LO" (inches W.C.)	2.7"	1"
Unit to Cornerwall	4"											
Front of Unit	36"											
Alcove Min. Height	58"											
Alcove Max Depth	45"											
Alcove Min Width	44"											

This room heater is equipped at the factory for use with natural gas. If conversion to propane (LP) fuel is desired the optional factory conversion kit #98900746 must be used.

Blower Electrical Rating: 115 V., 1.5 Amps, 60 Hz FAN TYPE VENTED CIRCULATOR

Manufacture Date: 1996 Jan. Apr. Jul. Oct. 1997 Feb. May Aug. Nov. 1998 Mar. Jun. Sep. Dec.

Travis Industries, Inc.
 10850 117th Pl. N.E. Kirkland, WA 98033

IGN

Stove Leg Installation (Brass # 99200500, Cast Black # 99200800, Black Steel # 99200100)

Raise the stove 8" (use lumber or other sturdy device). Attach each leg following the instructions below.

Attach each leg to the stove by inserting a bolt and washer through the hole or slot in the leg and into the threaded hole on the stove.

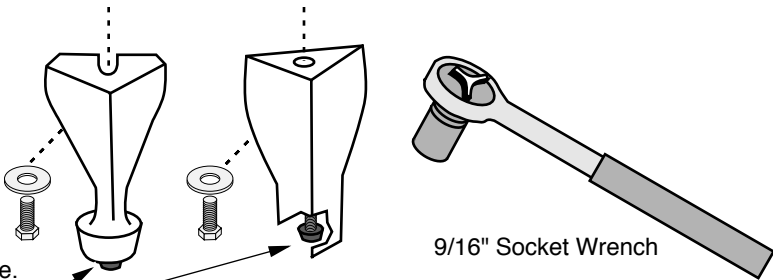

These rubber-tipped bolts are for leveling the stove. Make sure they contact the floor. Do not adjust with weight on the legs, the rubber tips may tear.

9/16" Socket Wrench

Pedestal (Part # 99200106)

Use a 9/16" wrench to attach the two pedestal bolts to the bottom of the stove.

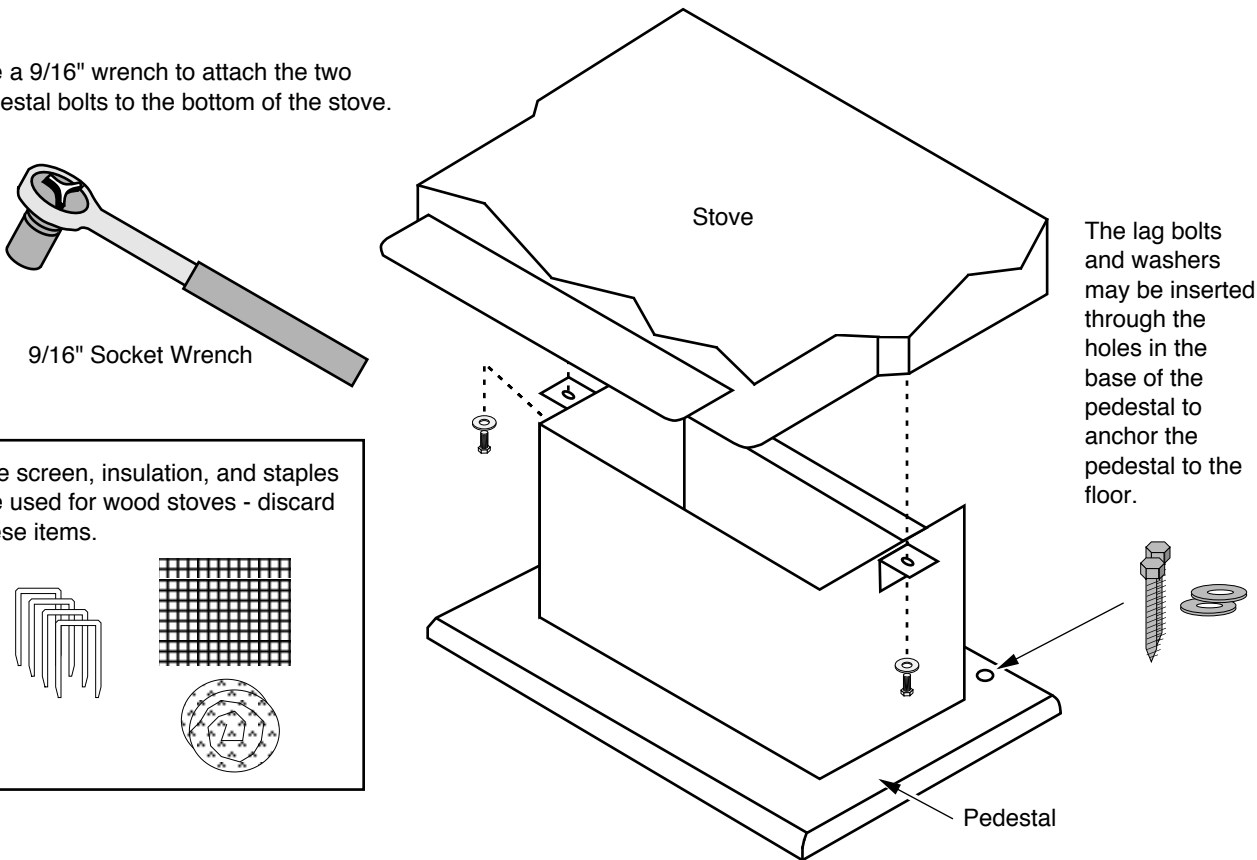

9/16" Socket Wrench

The lag bolts and washers may be inserted through the holes in the base of the pedestal to anchor the pedestal to the floor.

The screen, insulation, and staples are used for wood stoves - discard these items.

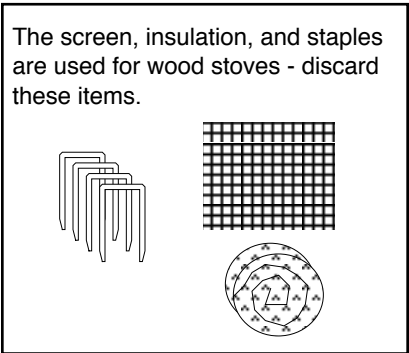

Stove

Pedestal

Thermostat (Part # 99300650)

! Do not connect 120 VAC to the gas control valve or wiring of this unit.

1 Attach the thermostat wire and route it under the burner pan (see the illustration below).

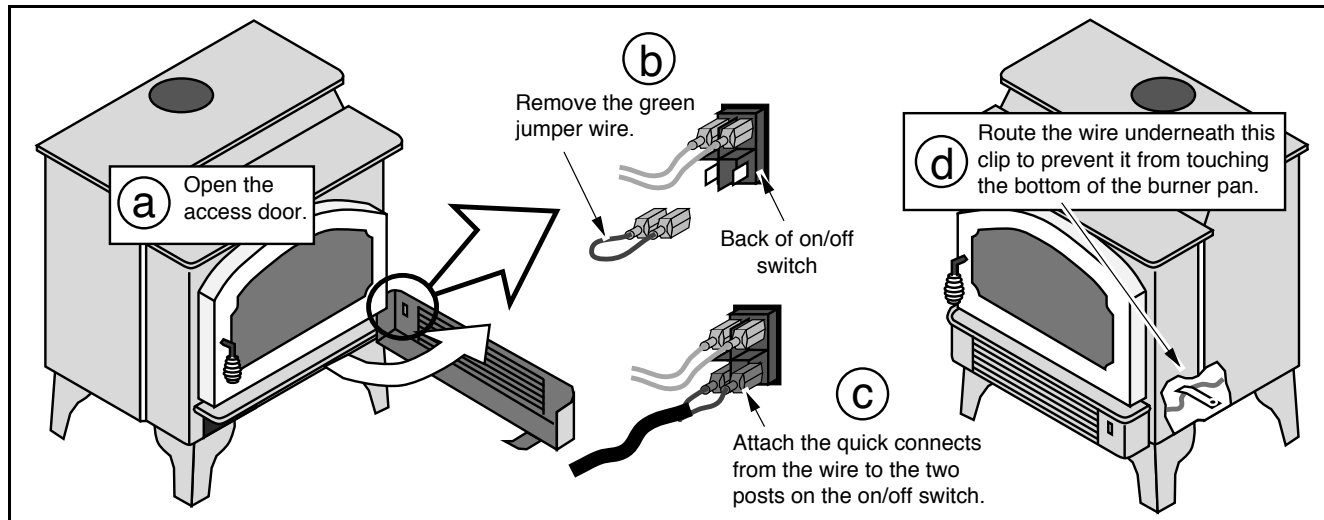

2 Route the thermostat wire through the gas inlet hole. Pull through all the slack (you may wish to wrap the wire in electrical tape where it passes through the heater to prevent damage to the wire). Determine a location for the thermostat that is within range of the 50' length of thermostat wire. It should be centralized in the room and away from the heater. The wire may be routed externally on the wall or behind the wall (preferred).

3 Install the thermostat following the directions below.

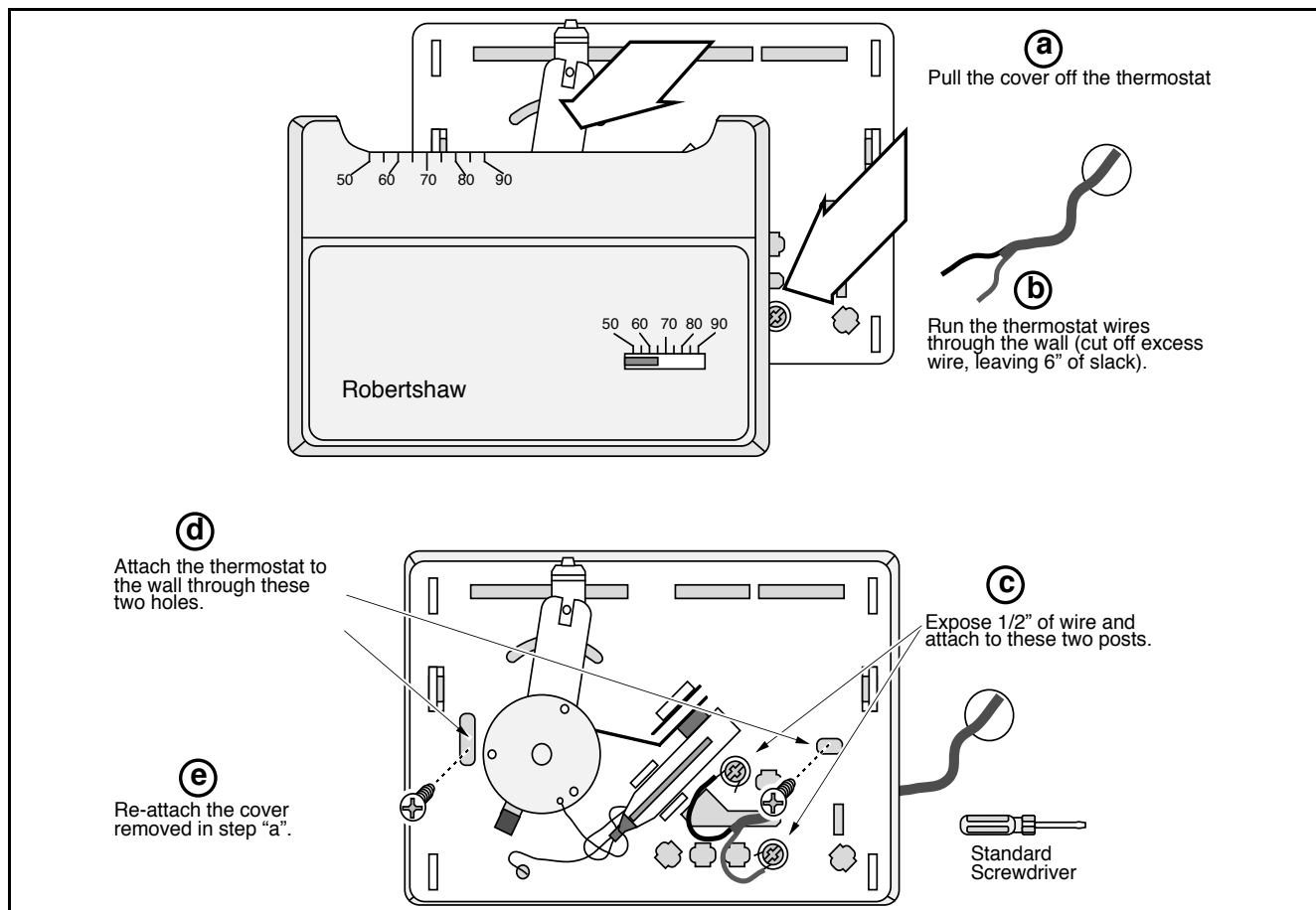

Remote Thermostat

- ! Do not connect 110-120 VAC to the gas control valve or wiring system of this unit.
- Follow the instructions included with the remote thermostat for installation.

IMPORTANT OPERATIONAL NOTE FOR REMOTE THERMOSTAT USE:

Included with the remote thermostat is a set of instructions that should be given to the homeowner. Please be aware that the remote thermostat has a 1 to 2 minute lag time between the time the thermostat is turned up and the heater turns on.

Propane Conversion Kit (Part # 989000746)

The propane conversion kit should be installed prior to installing the heater (if not, shut off gas and disconnect the heater from the gas line).

Items Needed For Assembly

- 1/4" Nutdriver
- 7/16" and 1/2" Open End Wrench
- Standard Screwdriver
- Phillips Screwdriver
- Micro (1/16") Standard Screwdriver
- Leak Testing Equipment
- Thread sealant

Packing List

- LP Orifice (#50 - stamped "50")
- LP Pilot Orifice (.016" dia. - stamped "16LP")
- Replacement Regulator
- Two Replacement Screws
- Regulator Gasket
- LP Label

Installation Instructions

- 1 Remove the door and glass to access the firebox (see pages 16 and 15).
- 2 Reach into the firebox and remove the rear log shelf (see illustration below).

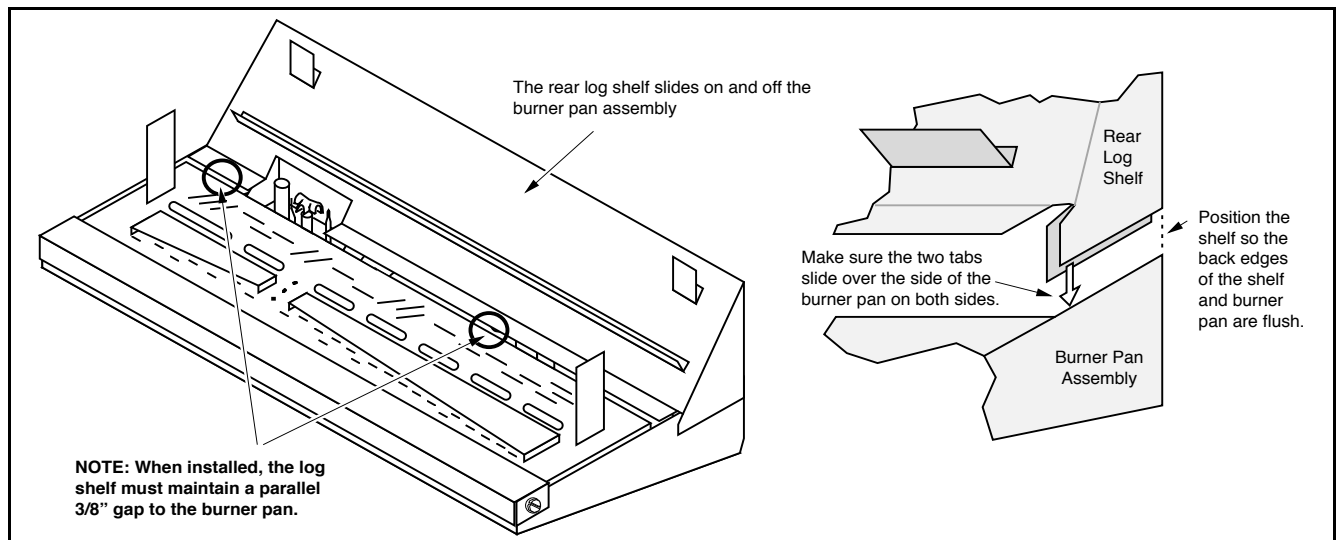

3 Remove the burner pan from the burner pan box following the instructions below.

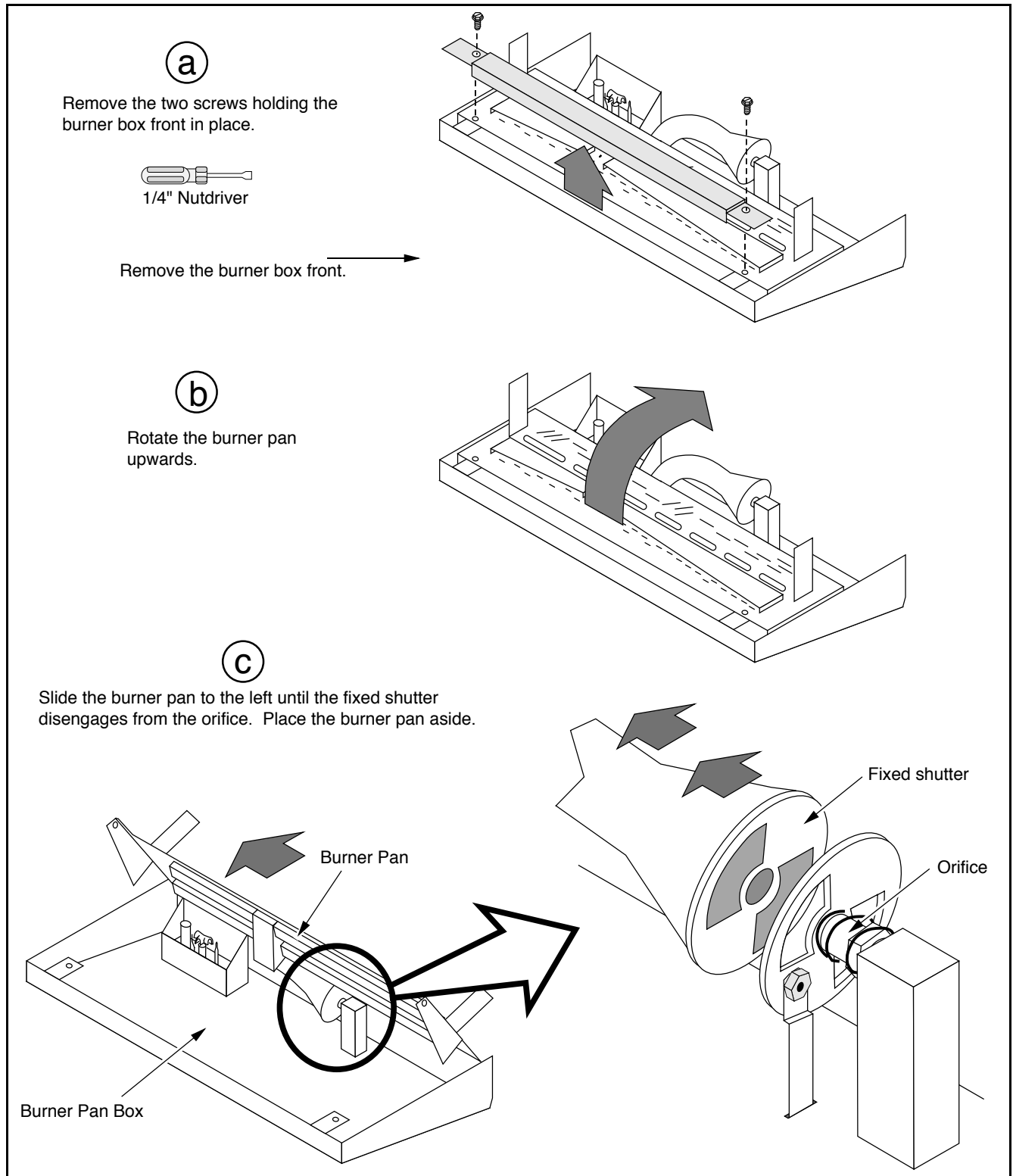

- 4 Follow the directions below to remove the natural gas orifice. Apply thread sealant to the LP orifice (#50 - it has "50" stamped on it) and tighten in place with a 1/2" open end wrench. Replace the spring. Slide the adjustable shutter back in place.

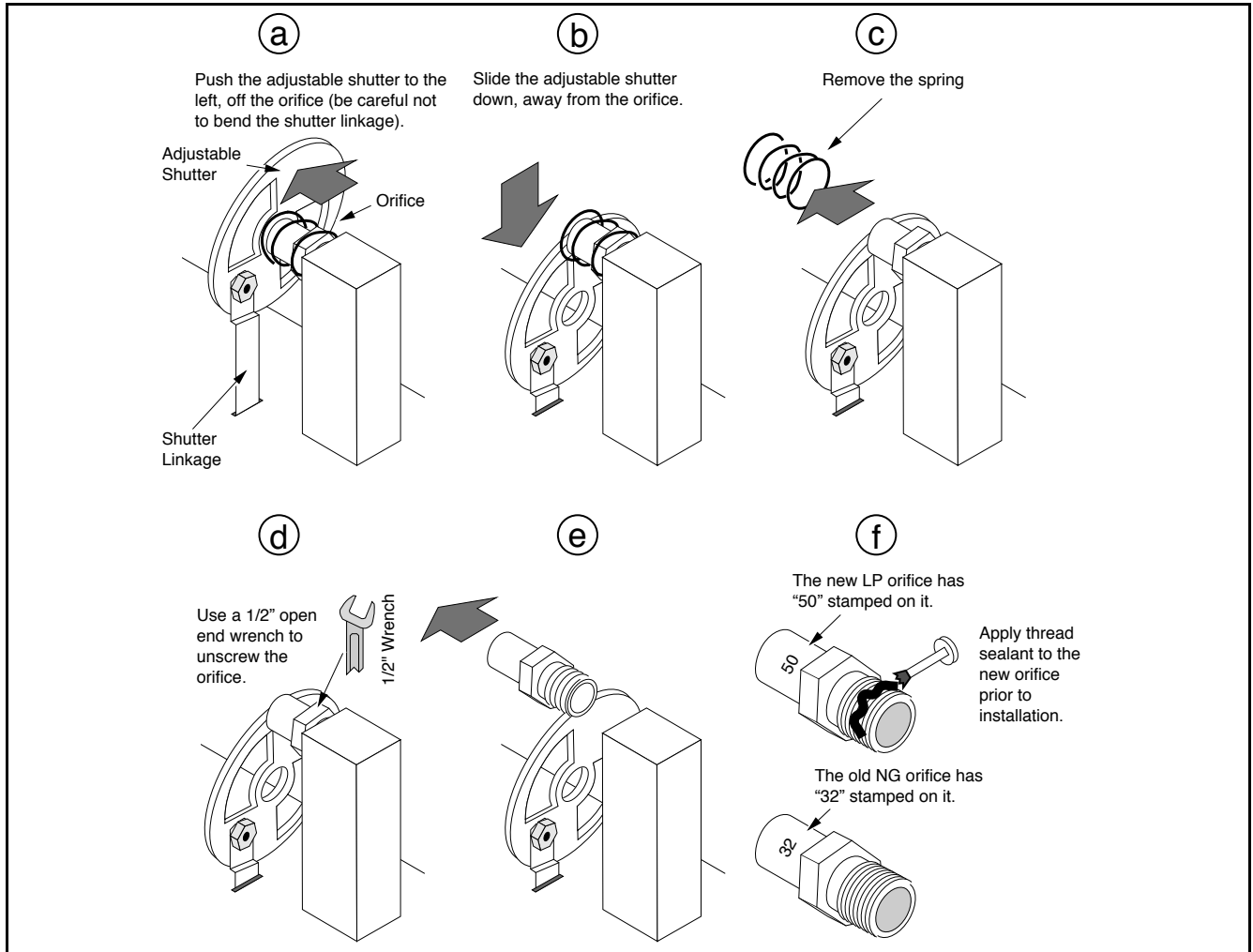

- 5 Re-attach the burner pan and burner box front to the burner pan box following the instructions in step 3 in reverse order.
- 6 Remove the pilot orifice following the instructions below. Replace with the propane pilot orifice. The propane conversion kit includes a .016" (labeled LP 16) or .011" (labeled LP 11) pilot orifice. The .016" orifice is preferred because it allows for larger pilot adjustment.

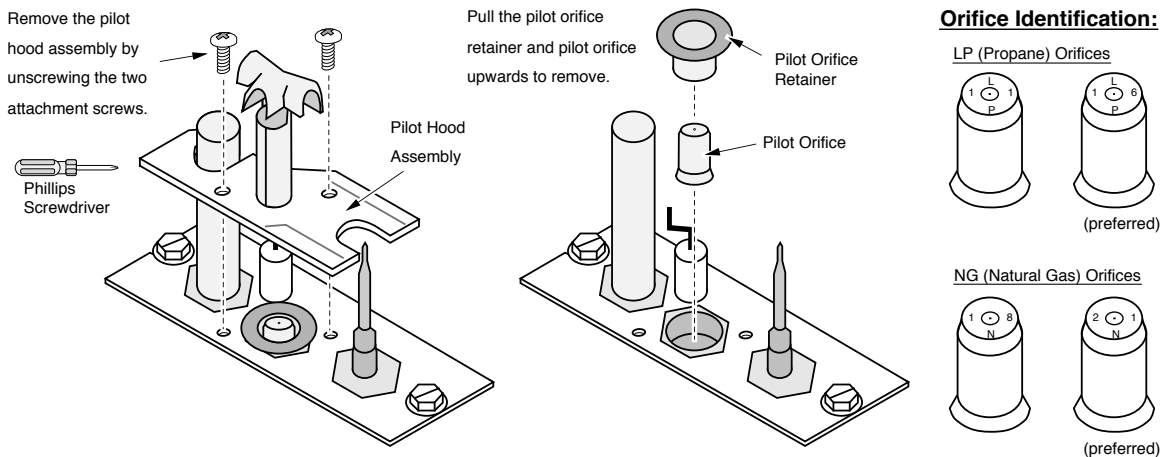

- 7 Replace the pilot assembly (follow the instructions in step 6 in reverse order). Make sure the pilot assembly gasket is placed correctly.
- 8 Replace the rear log shelf (see step 2). Install the logs and embers. Replace the glass and door.
- 9 Remove the regulator from the front of the gas control valve. Replace with the propane regulator, using the new gasket and screws included with the regulator. **NOTE: Leak test this area after the heater is installed, gas is connected, and the main burner is lit.**

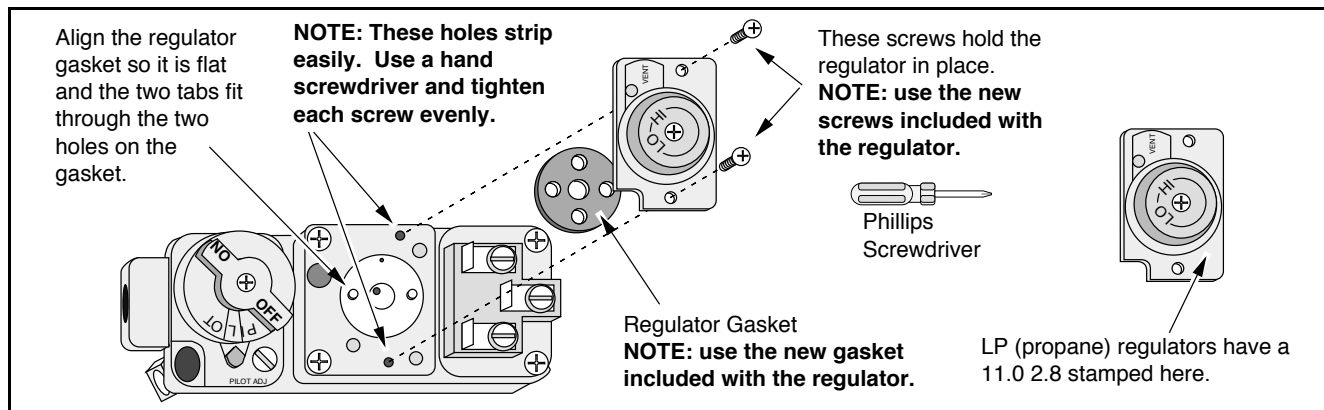

- 10 Place the included propane label over the natural gas label on top of the gas control valve.

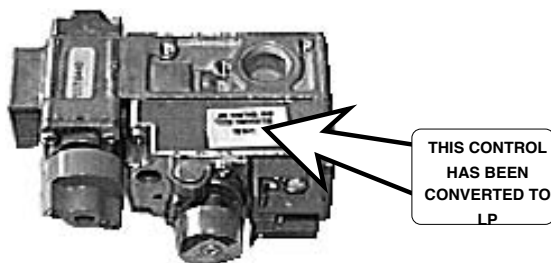

- 11 Make the gas line connection, start the heater and thoroughly leak-test all gas connections and the regulator. Check the pilot. Adjust if necessary.

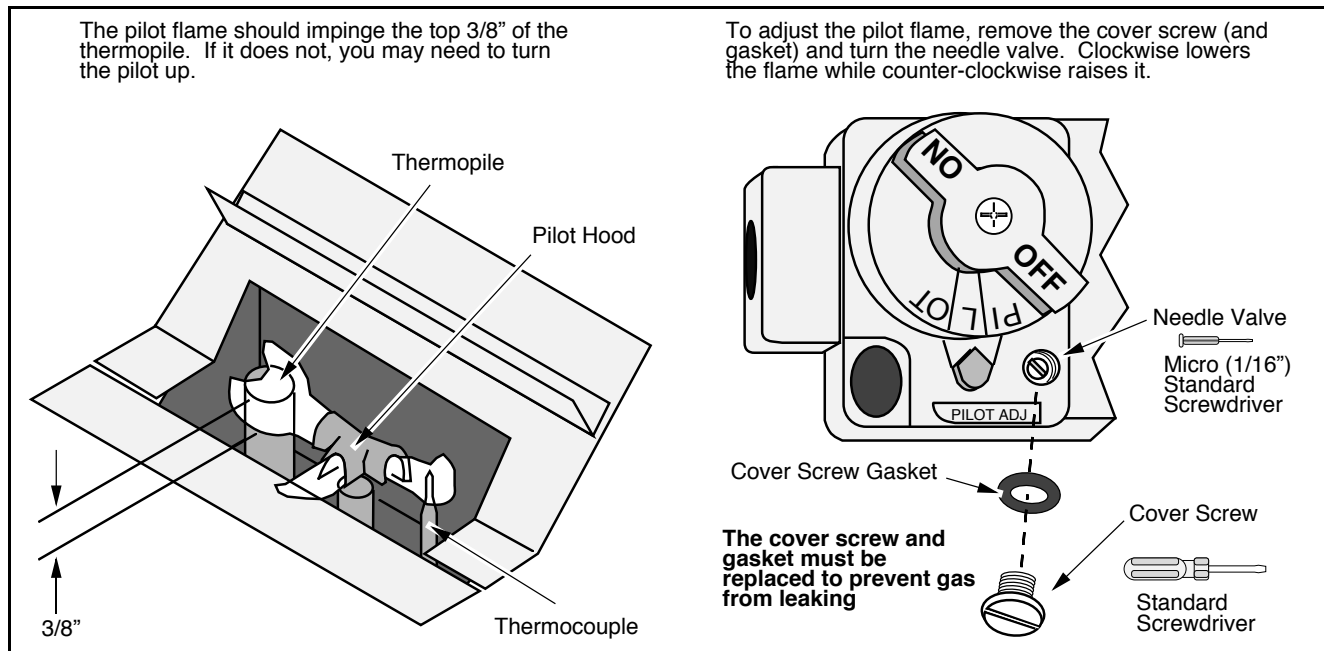

ADDENDUM #1 Altitude Considerations

This fireplace has been tested at altitudes ranging from sea level to 8,000 feet. In this testing we have found that the fireplace, with its standard orifice, burns correctly with just an air shutter adjustment. For information on adjusting the air shutter see page 17 of this manual.

- ! Failure to adjust the air shutter properly may lead to improper combustion which can create a safety hazard. Please consult your dealer or installer if you suspect an improperly adjusted air shutter.**

ADDENDUM #2 Class A Chimney Conversion Kit

Simpson Duravent provides a conversion kit for those wishing to use an existing wood stove chimney to vent this direct vent stove. The illustration below gives an overview of this type of installation. See the instructions included with the kit for details.

- ! The conversion kit does not work on interior masonry chimneys.**
- ! Do not exceed the maximum vertical rise (see the section "Approved Vent Configurations" starting on page 9) allowable. Remember to set the restrictor position to the correct position (based upon the vertical rise height - see the chart on page 10).**

Chimney Conversion Kit A (# 931)

Metalbestos 6" (150 mm) I.D.
 Security Chimneys 6" (150 mm) I.D.
 Jackes-Evans 6" (150 mm) I.D.
 Hart & Cooley 6" (150 mm) I.D.
 Pro-Jet 6" (150 mm) I.D.

Chimney Conversion Kit B (# 932)

Simpson Dura-Vent 6" (150 mm) I.D.
 Air-Jet 6" (150 mm) I.D.
 Metal-Fab 6" (150 mm) and 7" (175 mm) I.D.
 Amer. Metals 6" (150 mm) & 7" (175 mm) I.D.
 Metalbestos 7" (175 mm) and 8" (200 mm) I.D.
 Jackes-Evans 7" (175 mm) and 8" (200 mm) I.D.
 Hart & Cooley 7" (175 mm) and 8" (200 mm) I.D.
 Pro-Jet 7" (175 mm) and 8" (200 mm) I.D.
 Security Chimneys 8" (200 mm) I.D.

Chimney Conversion Kit C (# 933)

Simpson Dura-Vent 7" (175 mm) and 8" (200 mm) I.D.
 American Metals 8" (200 mm) I.D.
 Air-Jet 8" (200 mm) I.D.
 Metal-Fab 8" (200 mm) I.D.
 American Metals 8" (200 mm) I.D.

Each Kit Contains:

Retro Connector
 Retro Vertical Top

Additional Equipment:

4" Flex (#711 or U.L. 1777)
 Termination (#991)
 Co-Axial Sections

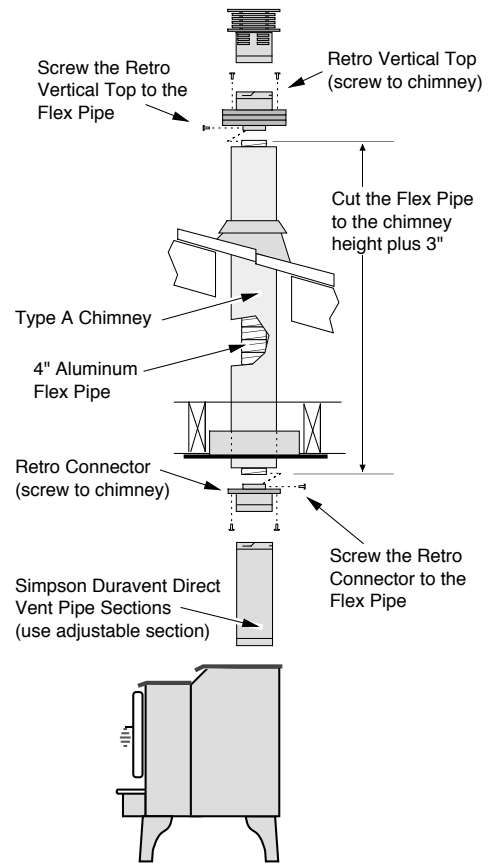

ADDENDUM #3 Interior Masonry Chimney Conversions

- Follow the requirements and use the equipment listed in the illustration to the right to install this appliance into an interior masonry chimney.
- Maximum vertical rise is 30'
- Minimum vertical rise is 10'
- Use the following restrictor positions:
 Position 7 for heights between 10' (3 M) and 24' (7.3 M)
 Position 5 for heights between 24' (7.3 M) and 30' (9.1 M)
NOTE: these restrictor positions are based upon lab tests. The ideal restrictor position may vary slightly.

The entire chimney system must be air-tight. Make sure to seal the flashing, clean-out, and thimble connection, and to inspect the chimney.

Make sure the coaxial pipe maintains a 1" clearance to any combustible. The vent must be sealed air-tight.

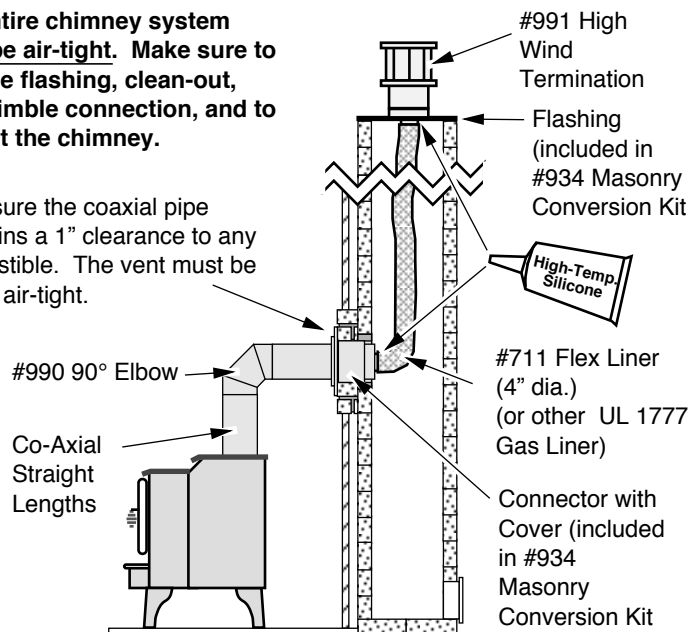

Blower Speed.....	21	Paint Curing.....	20
BTU Input.....	5	Pedestal (installation).....	28
Cap (vent termination).....	12	Pilot (starting).....	19
Clearances.....	6	Propane Conversion Kit (Installation).....	32
Controls.....	18	Propane Line Install (gas line install).....	7
Dimensions.....	5	Propane Verses Natural Gas Heater.....	2
Door (installation).....	16	Purging Gas Line.....	15
Emissions.....	5	Remote Control (installation).....	30
Fan Speed.....	21	Remote Control (operation).....	20, 31
Firebox (inspection).....	22	Running Your Heater.....	20
Flame Height (see step 8).....	17	Safety Label.....	27
Floor Protection.....	7	Safety Precautions.....	2
Fuel.....	5	Sounds (normal operating sounds).....	21
Gas Inlet Location.....	7	Starting The Pilot.....	19
Gas Leak..... See Inst. on Cover		Starting the Heater for the First Time.....	20
Gas Line Install.....	7	Stove Clearances.....	6
Gas Pressure.....	7	Table of Contents.....	4
Gas Smell..... See Inst. on Cover		Thermostat (installation).....	29
Heater Placement.....	7	Thermostat (operation).....	20
Heating Specifications.....	5	Troubleshooting Table.....	23
How this Heater Works.....	24	Turning the Heater On and Off.....	20
Leaking Gas..... See Inst. on Cover		Vent Requirements.....	8
Listing Information.....	27	Vent termination.....	13
Logs and Ember (installation, removal).....	15	Warranty.....	26
Natural Gas Verses Propane Heater.....	2	Weight.....	5
On/Off Operation.....	20	What Prevents Gas Buildup.....	24
Operating Sounds.....	21	What Turns the Main Burners On and Off.....	24
Operating the Heater.....	18	Why Nothing Should Be Placed Against the Heater ...	25
Packing List.....	6	Wiring Diagram.....	25