

# Smartstove™

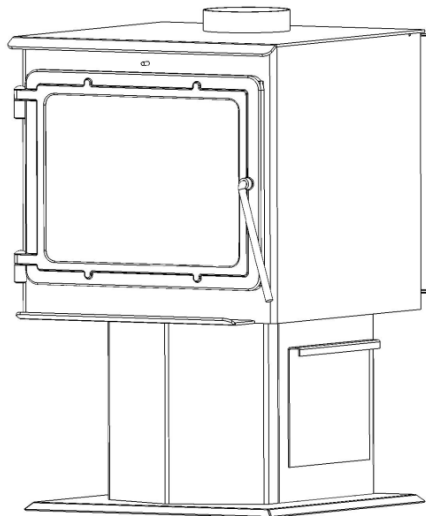

## THE MADISON

15-SSW01, 50-SHSSW01, 50-TRSSW01  
INSTALLATION & OPERATION MANUAL



Manufactured By:  
England's Stove Works, Inc.  
PO Box 206  
Monroe, VA 24574

Rev. 04/14



### CAUTION

Please read this entire manual before installation and use of this wood fuel-burning appliance. Keep children, furniture, fixtures and all combustibles away from any heating appliance.

### SAVE THESE INSTRUCTIONS

### SAFETY NOTICE

Failure to follow these instructions can result in property damage, bodily injury or even death. For your safety and protection, follow the installation instructions outlined in this manual. Contact your local building or fire officials about restrictions and installation inspection requirements (including permits) in your area.

**IMPORTANT: IF YOU HAVE A PROBLEM WITH THIS UNIT, DO NOT RETURN IT TO THE DEALER. CONTACT TECHNICAL SUPPORT @ 1-800-245-6489**

**Mobile Home Use (Approved for USA only):**

This freestanding wood unit is approved for mobile home or doublewide installation with the outside combustion air hook-up. See the "Installation" section of this manual for details pertaining to mobile home installations. Mobile home installation must be in accordance with the Manufactured Home and Safety Standard (HUD), CFR 3280, Part 24.

### **Retain for your files**

Model Number \_\_\_\_\_

Date of Purchase \_\_\_\_\_

Date of Manufacture \_\_\_\_\_

Serial Number \_\_\_\_\_

\* This information can be found on the safety tag attached to the rear of the unit. Have this information on hand if you phone the factory or your dealer regarding this product.

### **CAUTION**

- Keep children away.
- Supervise children in the same room as this appliance.
- Alert children and adults to the hazards of high temperatures.
- Do NOT operate with protective barriers open or removed.
- Hot while in operation! Keep clothing, furniture, draperies and other combustibles away. Contact may cause skin burns!
- Installation MUST comply with local, regional, state and national codes and regulations.
- Consult local building, fire officials or authorities having jurisdiction about restrictions, installation inspection, and permits.

# TABLE OF CONTENTS

## Introduction

- Introduction ..... 4

## Specifications

- Heating Specifications..... 5
- Dimensions..... 5
- EPA Compliance ..... 5

## Installation

- Installation Overview ..... 6
- Clearances to Combustibles..... 7
- Venting Introduction..... 8
- Venting Guidelines..... 8
- Additional Venting Information ... 9
- Wall Pass-Throughs..... 10
- Approved Venting Methods
  - Through the Wall ..... 11
  - Through the Ceiling..... 12
  - Masonry Chimney ..... 13
  - Masonry Fireplace ..... 14
- Mobile Home Installation ..... 15
- Outside Air Hook-Up ..... 14
- Floor Protection ..... 16

## Operation

- Break-In Fires ..... 17
- Continuous Operation..... 17-18
- Safety Notes ..... 19

## Maintenance

- Stove Maintenance ..... 20

- Inspecting Gaskets ..... 21
- Finish ..... 21

## Replacing Components

- Glass ..... 22
- Burner Tubes ..... 23
- Ceramic Fiberboards..... 23
- Door Hinges ..... 23
- Heat Shield & Back Panel ..... 23
- Other Components..... 24

## Optional Accessories

- AC-16/AC-30 Blower ..... 24
- Side Heat Shield ..... 24

## Troubleshooting Guide

- Troubleshooting..... 25

## Illustrated Parts Detail

- Parts List..... 26
- Exploded Parts Diagram..... 27
- Brick Layout ..... 28

## Warranty

- Sample Tag..... 29
- Warranty Details ..... 30
- Important Notice ..... 31
- Warranty registration Form ..... 32

**NOTE: CLEARANCES MAY ONLY BE REDUCED BY MEANS APPROVED BY THE REGULATORY AUTHORITY HAVING JURISDICTION**

**DO NOT CONNECT TO ANY AIR DISTRIBUTION DUCT OR SYSTEM.**

**DO NOT BURN GARBAGE OR FLAMMABLE FLUIDS SUCH AS GASOLINE, NAPHTHA OR ENGINE OIL.**

**DO NOT USE CHEMICALS OR FLUIDS TO START THE FIRE.**

## INTRODUCTION

Thank you for purchasing this fine product from England's Stove Works!

England's Stove Works was started, and is still owned by, a family that believes strongly in a "Do It Yourself" spirit; that's one reason you found this product at your favorite "Do It Yourself" store.

We intentionally design and build our stoves so that any homeowner can maintain their unit with basic tools, and we're always more than happy to show you how to do the job as easily and as inexpensively as possible. However, while remaining simple, our stoves are designed to perform extremely efficiently, helping deliver more heat from less fuel.

Please look at our vast Help section on our website and call our Technical Support Department at (800) 245-6489 if you need any help with your unit. We are nearly always able to "walk you through" any installation issues, repairs, problems or other questions that you may have.

Wishing you years of efficient, quality and "comfy" heating,

### EVERYONE AT ENGLAND'S STOVE WORKS

**Please Note:** While information obtained from our web site and through our Technical Support line is always free of charge, there will be a service charge incurred with any "on-site" repairs or maintenance that we may arrange.

# SPECIFICATIONS

## Heating Specifications

- Maximum Heat Output .....50,000 BTU/hr
- Maximum Burn Time\*\* ..... 6-8 hours
- Approximate Square Footage Heated\*\*\* ..... 1800 sq. ft.
- Firebox Capacity..... 35 pounds
- Flue Collar ..... 6.0 in. round

## Dimensions (Inches)

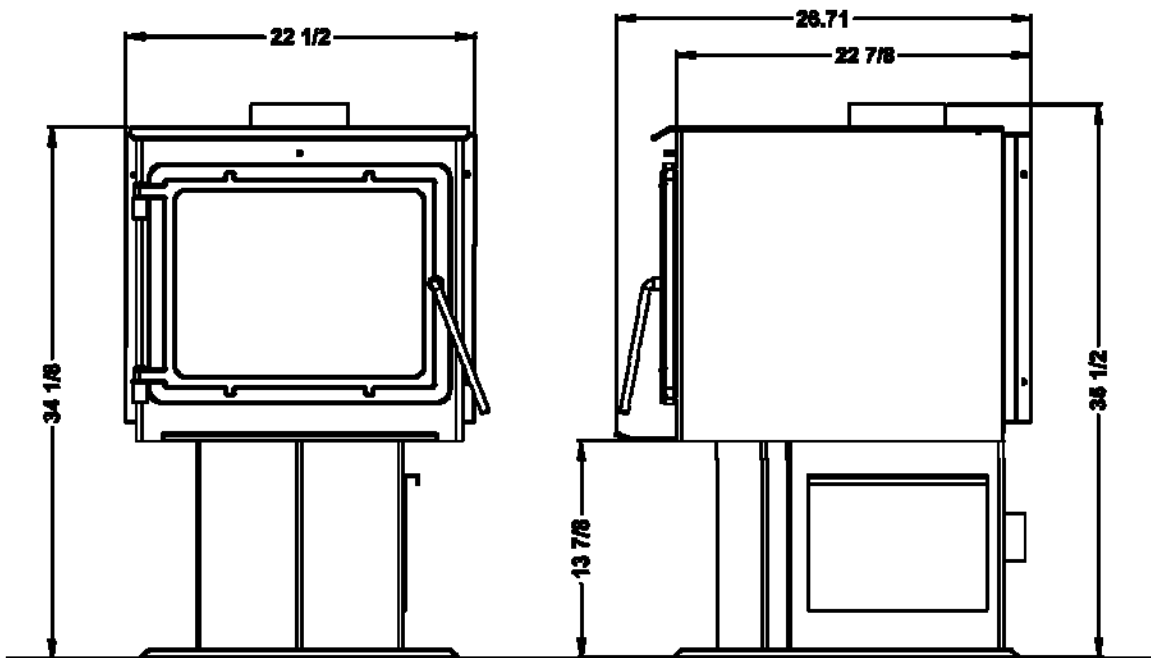

## EPA and Safety Compliance Specifications

- EPA Compliance .....Certified
- Particulate Emissions ..... 2.49 grams/hr
- Efficiency\* .....72% HHV (78% LHV)
- Tested To..... UL-1482, ULC-S627-00

\*\* - Maximum burn times are heavily dependent on the type of wood burned in the stove; as such, these numbers may vary.

\*\*\* - The maximum heating capacity of this unit can vary greatly based on climate, construction style, insulation and a myriad of other factors. Use this information in conjunction with a BTU loss calculation for your home to determine if this unit will be sufficient for your needs.

# INSTALLATION

## Installation Overview

When choosing a location for your new stove, there are a multitude of factors that should be taken into account before beginning the installation.

1. Traffic Patterns – To help prevent accidents, the stove should be placed in a location where it is out of the way of normal travel through the home.
2. Heat Flow – When deciding on a location for the stove, consider the way heat moves throughout your home. Install the stove where you need the heat; basement installations often do not allow sufficient heat to flow to the upper floors and a top floor installation will not allow any heat to reach the floors below. Always consider that heat rises and will take the path of least resistance while it is still hot.
3. Exhaust Location – The engine which drives a wood stove is the chimney system, so it is important to consider precisely how the chimney system will be integrated into the stove installation. Ideally, a wood stove chimney will run completely vertical from the flue collar of the unit all the way to the termination point above the roof line. Keeping the entire chimney system inside the heated envelope of the home will ensure a strong, easy to initiate draft in the chimney. Although exterior chimney systems often function properly, they are more likely to suffer from cold down drafts at start up or provide weak draft to the unit. Also, consider the cross-sectional area of the chimney; although existing masonry chimneys can often be used, a large external masonry chimney will result in a unit that is difficult or impossible to operate properly. In that case, an insulated chimney liner will often be required to supply the necessary draft.
4. Wall Construction – Locating the stove so that the exhaust system can pass between studs will simplify the installation and eliminate the need to reframe any sections of the wall or ceiling to accommodate the wall thimble or ceiling box.

### **WARNING**

- Do not store or use gasoline or other flammable vapors and liquids in the vicinity of this or any other appliance.
- Do Not Over-fire – If any external part starts to glow, you are over-firing. Reduce intake air supply. Over-firing will void your warranty.
- Comply with all minimum clearances to combustibles as specified. Failure to comply may result in a house fire.
- Tested and approved for **cordwood only**. Burning any other fuel will void your warranty.

# INSTALLATION

## Clearances to Combustibles

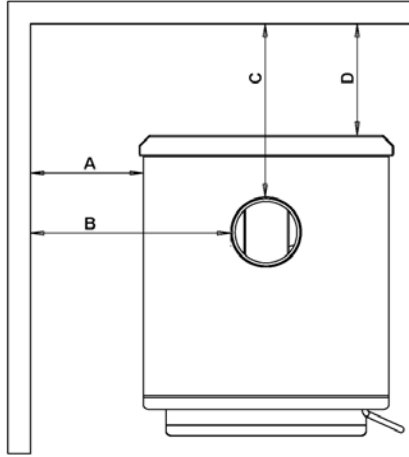

*Parallel  
Wall Installation*

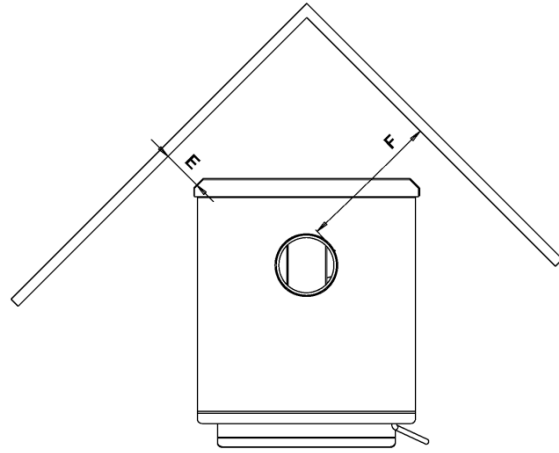

*Corner Installation*

	Unit to Side Wall *	Chimney Connector to Side Wall	Chimney Connector to Rear Wall	Unit to Rear Wall	Unit to Corner	Chimney Connector to Corner
	A	B	C	D	E	F
	in. (mm.)	in. (mm.)	in. (mm.)	in. (mm.)	in. (mm.)	in. (mm.)
Single Wall Chimney Connector Unprotected Surface	21.5 (546.1)	29 (736.6)	12 (304.8)	7.5 (190.5)	9.5 (241.3)	19 (482.6)
Double Wall Chimney Connector Unprotected Surface	N/A	N/A	N/A	N/A	N/A	N/A
Single Wall Chimney Connector Unprotected Surface with side shields.	17.5 (445.5)	25 (635)	12 (304.8)	7.5 (190.5)	5.5 (139.7)	15 (381)
Double Wall Chimney Connector Unprotected Surface with side shields.	N/A	N/A	N/A	N/A	N/A	N/A

## INSTALLATION

### Venting Introduction

This wood stove operates on a natural draft system, in which the chimney system pulls air through the stove. This unit must be installed in accordance with the following detailed descriptions of venting techniques; not installing the stove in accordance with the details listed here can result in poor stove performance, property damage, bodily injury or death. Avoid make-shift compromises when installing the venting system. England's Stove Works is not responsible for any damage incurred due to a poor or unsafe installation.

Be certain that all aspects of the venting system are installed to the venting manufacturer's instructions, particularly the required clearances to combustibles. Also, be certain to use an attic radiation shield to prevent insulation from contacting a chimney which passes through an attic.

The chimney system is the "engine" which drives a wood stove, so it is imperative for proper unit function that the venting system be installed exactly as described in the following section.

If questions arise pertaining to the safe installation of the stove, our Technical Support line (800-245-6489) is available. Contact your local code official to be certain your installation meets local and national fire codes, and if you're uncertain about how to safely install the stove, we strongly recommend contacting a local NFI certified installer to perform the installation.

### Venting Guidelines

- **ALWAYS** install vent pipe in strict adherence to the instructions and clearances included with your venting system.
- **DO NOT** connect this wood stove to a chimney flue which also serves another appliance.
- **DO NOT** install a flue pipe damper or any other restrictive device in the exhaust venting system of this unit.
- **USE** an approved wall thimble when passing through a wall and a ceiling support/fire stop when passing through a ceiling.
- **INSTALL** three sheet metal screws at every chimney connector joint.
- **AVOID** excessive horizontal runs and elbows, as both will reduce the draft of the venting system and will result in poor stove performance.
- **INSPECT** your venting system often, to be certain it is clear of creosote, fly-ash and other restrictions.
- **CLEAN** the venting system as detailed in the maintenance section of this manual.
- **ADHERE** to the 10-3-2 rule regarding chimney terminations.
- **INSTALL** single wall chimney connector with the male end **down** to prevent creosote leakage. Follow double wall chimney connector manufacturer's instructions regarding proper pipe installation.

**WARNING:** Venting system surfaces get HOT, and can cause burns if touched. Noncombustible shielding or guards may be required.



# INSTALLATION

## Additional Venting Information

- Do not mix and match components from different pipe manufacturers when assembling your venting system (i.e. Do **NOT** use venting pipe from one manufacturer and a thimble from another).
- We **require** a minimum chimney height of 15.0 ft. Chimney systems shorter than this may not create the amount of draft which is required to operate this wood burning unit.
- Do not use makeshift compromises when installing the venting system; have existing chimney systems inspected before use and be certain all new chimney systems are installed to the manufacturer's specifications and with only UL listed components (ULC if Canada).
- Prefabricated venting systems used for this stove must be listed to ULC S629 (Canada) and UL 103HT (US).
- Never install a draft inducer or any other system which increases the natural draft of the chimney; similarly, do not install a barometric or stovepipe damper with this unit.
- Never use single wall or double chimney connector as a chimney system; never pass either type of chimney connector through a combustible wall without carefully following the manufacturer's instructions and those listed in the following page on Wall Pass-Throughs. NEVER pass chimney connector through an attic, floor, closet or roof.
- Only use 24 gauge MSG black single wall chimney connector or UL Listed (ULC if Canada) double wall chimney connector.

## Single Wall Chimney Connector Installation

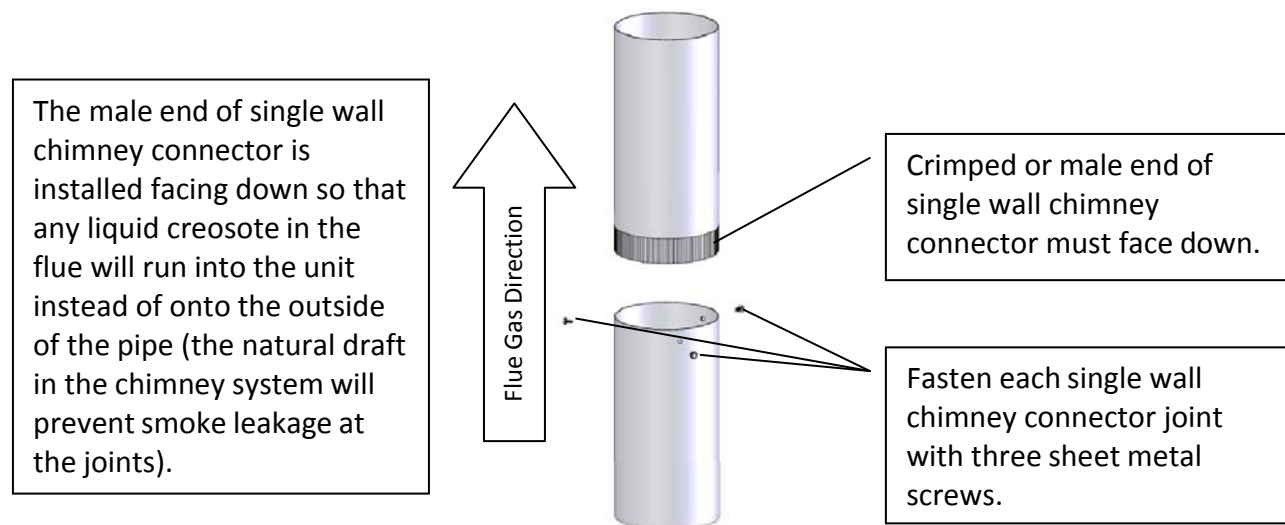

## **WARNING**

- INSTALL VENT AT CLEARANCES SPECIFIED BY THE VENT MANUFACTURER.
- HOT! Do not touch! Severe burns or clothing ignition may result.
- Glass and other surfaces are hot during operation.

# INSTALLATION

## Wall Pass-Throughs

### Chimney Connector Systems and Clearances from Combustible Walls for Residential Heating Appliances

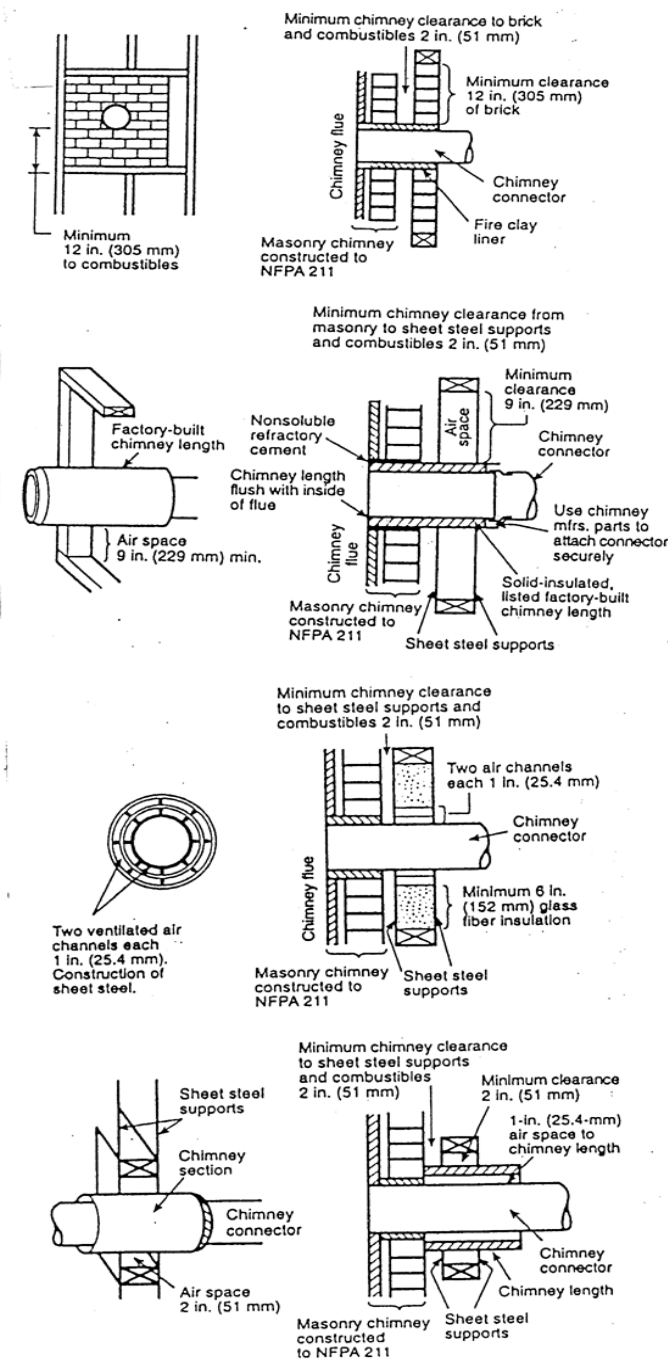

A Minimum 3.5-in thick brick masonry all framed into combustible wall with a minimum of 12-in brick separation from clay liner to combustibles. The fireclay liner shall run from outer surface of brick wall to, but not beyond, the inner surface of chimney flue liner and shall be firmly cemented in place.

B Solid-insulated, listed factory-built chimney length of the same inside diameter as the chimney connector and having 1-in. or more of insulation with a minimum 9-in. air space between the outer wall of the chimney length and combustibles.

C Sheet steel chimney connector, minimum 24 gauge in thickness, with a ventilated thimble, minimum 24 gauge in thickness, having two 1-in. air channels, separated from combustibles by a minimum of 6-in. of glass fiber insulation. Opening shall be covered, and thimble supported with a sheet steel support, minimum 24 gauge in thickness.

D Solid insulated, listed factory-built chimney length with an inside diameter 2-in. larger than the chimney connector and having 1-in. or more of insulation, serving as a pass-through for a single wall sheet steel chimney connector of minimum 24 gauge thickness, with a minimum 2-in. air space between the outer wall of chimney section and combustibles. Minimum length of chimney section shall be 12-in. chimney section spaced 1-in. away from connector using sheet steel support plates on both ends of chimney section. Opening shall be covered, and chimney section supported on both sides with sheet steel supports securely fastened to wall surfaces of minimum 24 gauge thickness. Fasteners used to secure chimney section shall not penetrate chimney flue liner.

In Canada, the installation must conform to CAN/CSA-8365 when passing through combustible construction.

# INSTALLATION

## Approved Venting Method 1: Through the Wall Factory Built Chimney

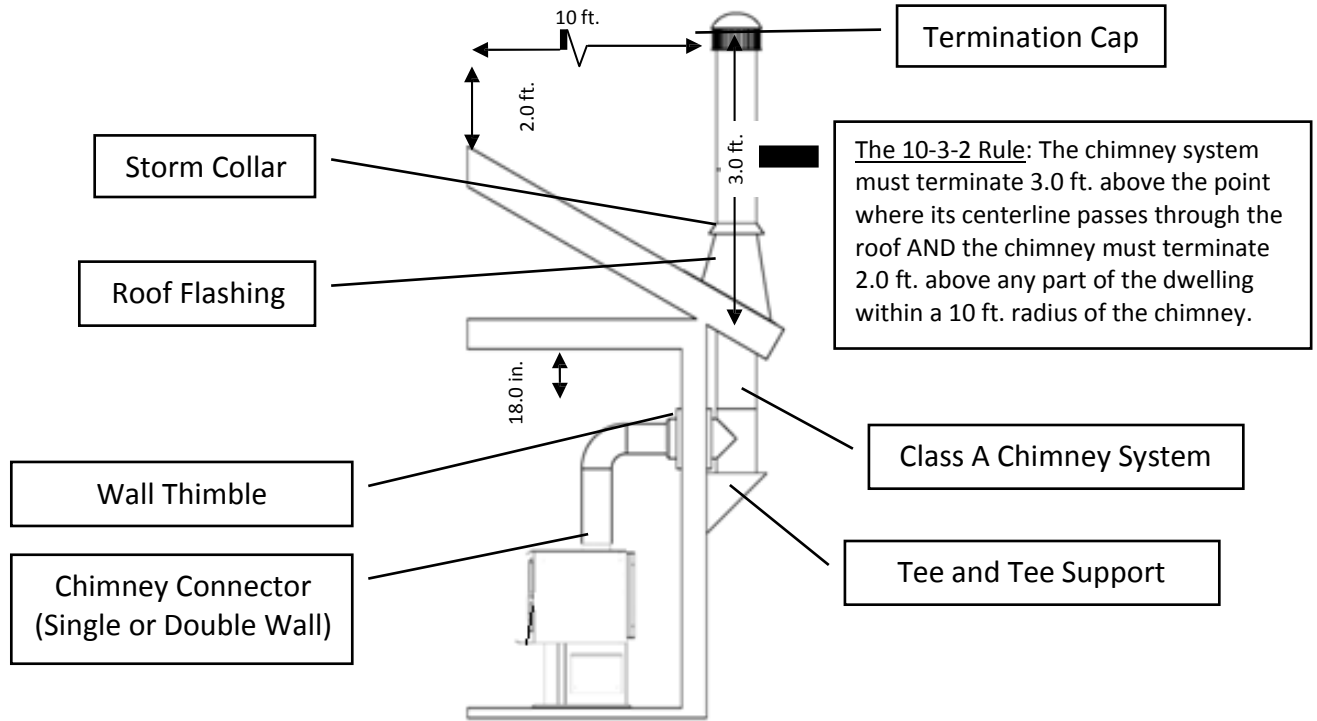

- Prefabricated chimney systems must conform to UL-103HT (2100 °F) for the U.S. and ULC-S629 (650°C) for Canada.
- This wood burning unit is only listed for installation with 6.0" diameter chimney connector and chimney systems. Installing this unit on prefabricated chimneys larger than 6.0" diameter will result in decreased draft and the potential for poor unit performance.
- Follow all venting system manufacturer's installation requirements and required clearances.
- Use three sheet metal screws at each single wall chimney connector joint (check manufacturer's recommendations when double wall chimney connector is used).
- Drill three holes in the flue collar of the unit and attach the chimney connector to the unit using sheet metal screws (holes should be pre-drilled in flue collar from factory).
- Properly attach the prefabricated chimney system to the home in strict accordance with the prefabricated chimney system manufacturer's instructions.
- Avoid numerous elbows and excessive horizontal runs as both will lead to poor draft and increased creosote accumulation. Horizontal runs of chimney connector must never exceed 4.0 ft. and the overall length of the chimney connector must not exceed 8.0 ft.
- Special adapters and slip connectors are available to eliminate the need to cut single wall chimney connector. Double wall chimney connector must be used with these slip connectors, as it cannot be trimmed to length.

**Please Note:** Installation diagrams are for reference purposes only and are not drawn to scale, nor meant to be used as plans for each individual installation. Please follow all venting system requirements, maintain the required clearances to combustibles, and follow all local codes.

# INSTALLATION

## Approved Venting Method 2: Through the Ceiling

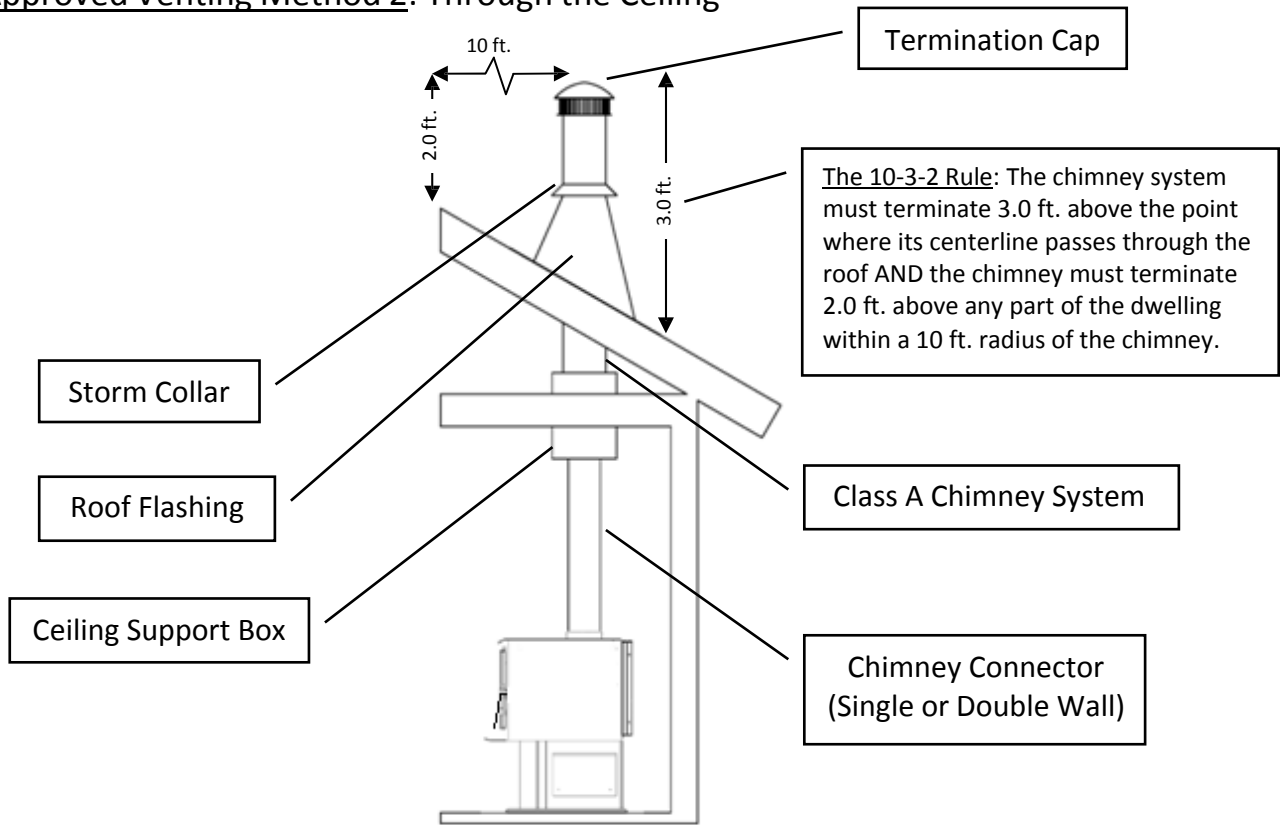

- Prefabricated chimney systems must conform to UL-103HT (2100 °F) for the U.S. and ULC-S629 (650°C) for Canada.
- This wood burning unit is only listed for installation with 6.0" diameter chimney connector and chimney systems. Installing this unit on prefabricated chimneys larger than 6.0" diameter will result in decreased draft and the potential for poor unit performance.
- Follow all venting system manufacturer's installation requirements and required clearances.
- Use three sheet metal screws at each single wall chimney connector joint (check manufacturer's recommendations when double wall chimney connector is used).
- Drill three holes in the flue collar of the unit and attach the chimney connector to the unit using sheet metal screws (holes should be pre-drilled in flue collar from factory).
- Properly attach the prefabricated chimney system to the home in strict accordance with the prefabricated chimney system manufacturer's instructions.
- The overall length of the chimney connector must not exceed 8.0 ft. In the case of cathedral ceilings, the prefabricated chimney system should extend to 8.0 ft. from the top of the unit.
- Special adapters and slip connectors are available to eliminate the need to cut single wall chimney connector. Double wall chimney connector must be used with these slip connectors, as it cannot be trimmed to length.

**Please Note:** Installation diagrams are for reference purposes only and are not drawn to scale, nor meant to be used as plans for each individual installation. Please follow all venting system requirements, maintain the required clearances to combustibles, and follow all local codes

# INSTALLATION

## Approved Venting Method 3: Internal or External Masonry Chimney System

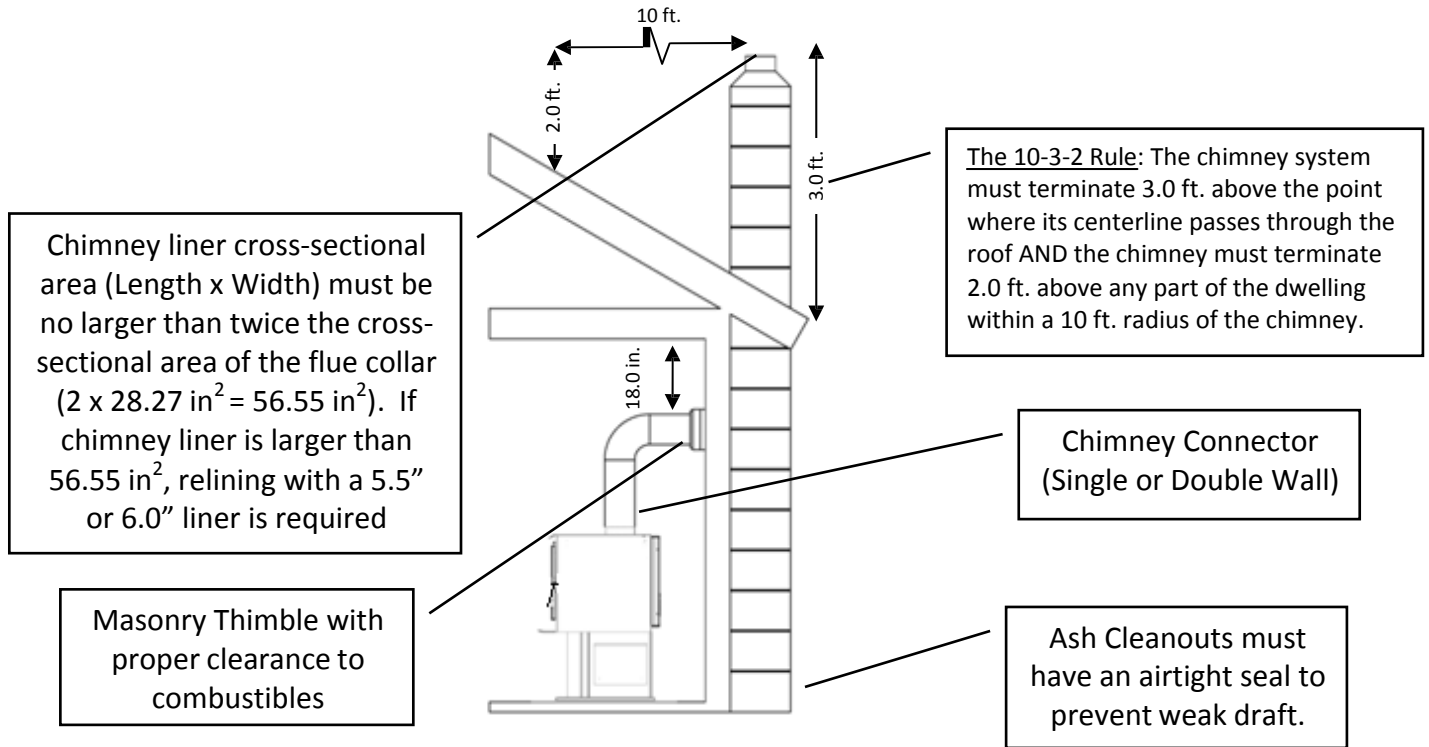

- Follow the rules listed above concerning maximum permissible flue liner size; installing this unit on masonry chimneys exceeding  $56.55 \text{ in}^2$  in cross-sectional area will result in decreased draft and the potential for poor unit performance.
- Use three sheet metal screws at each single wall chimney connector joint (check manufacturer's recommendations when double wall chimney connector is used).
- Drill three holes in the flue collar of the unit and attach the chimney connector to the unit using sheet metal screws (holes should be pre-drilled in flue collar from factory).
- Avoid numerous elbows and excessive horizontal runs as both will lead to poor draft and increased creosote accumulation. Horizontal runs of chimney connector must never exceed 4.0 ft. and the overall length of the chimney connector must not exceed 8.0 ft.
- A tight seal at the thimble is crucial for proper unit performance and to create a safe installation. Use the proper adapter designed for connecting single or double wall chimney connector to a masonry thimble.
- Have existing masonry chimneys inspected for safety and proper clearances to combustibles before putting them into service; a qualified chimney sweep can perform this inspection.
- External masonry chimneys often suffer cold downdrafts and poor draft performance even when they meet the cross-sectional area rules. In this case, a 6.0" insulated liner may be necessary.

**Please Note:** Installation diagrams are for reference purposes only and are not drawn to scale, nor meant to be used as plans for each individual installation. Please follow all venting system requirements, maintain the required clearances to combustibles, and follow all local codes.

# INSTALLATION

## INSTALLATION INTO A MASONRY FIREPLACE

### Preparation

Measure your hearth to ensure it is large enough to accept the unit.

Unit must have a 36" clearance from the top of the stove to a mantel in accordance with NFPA 211

For the USA: Hearth must extend at least 16 in. from the front of the fuel opening.

For Canada: Hearth must extend at least 18 in (450.0 mm) from the front of the fuel opening.

**Keep in mind that this type of a installation will make it difficult to change speeds on the blower frequently. We recommend picking a blower speed and sticking with it, since adjusting the blower will be difficult because of the tight installation.**

WARNING: DO NOT ATTEMPT TO ADJUST BLOWER DURING OPERATION. SKIN BURNS MAY OCCUR WHEN MAKING CONTACT WITH THE UNIT. WAIT FOR UNIT TO COMPLETELY COOL BEFORE ATTEMPTING TO ADJUST BLOWER.

Inspect your hearth to be sure it is constructed of a noncombustible material such as brick or stone. Do **not** install this stove on a hearth that is constructed of wood framework that is covered by brick or stone and do **not** install this unit in a zero (0) clearance fireplace. The manufacturer will not be held responsible for an accident resulting from this stove being installed on a hearth constructed of a combustible material.

Inspect your fireplace to ensure it is in proper working order and free of any obstructions.

Prior to installation, remove the existing damper or wire it to fasten it open.

### Venting Your Stove - Direct Connect

When this unit is direct connected it will require six inch (6") diameter 24 gauge pipe from the stove through the damper opening. **(NOTE: The chimney connector must be attached to the appliance with a minimum of three (3) screws, and 3 screws should be used to attach each adjoining section.)**

We highly recommend having the chimney fully lined with a 6 inch liner to ensure proper draft. This will make it necessary to block off the open area on both sides of the pipe that passes through the damper opening, which can be done with sheet metal or by packing flame retardant fiberglass insulation in the open areas (no paper or combustibles). You must be sure the draft from the chimney is being pulled through the stove, and not around the connector pipe. .

We highly recommend you have this done by a professional. You should also contact your local authorities to be sure you are following all codes.

# INSTALLATION

## WARNING

DO NOT INSTALL IN A SLEEPING ROOM.

## CAUTION

THE STRUCTURAL INTEGRITY OF THE MANUFACTURED HOME FLOOR, WALL AND CEILING/ROOF MUST BE MAINTAINED.

## Caution

**NEVER** draw outside combustion air from: Wall, floor or ceiling cavity or enclosed space such as an attic, garage or crawl space.

### Mobile Home Installation (USA ONLY, NOT APPROVED FOR CANADIAN MOBILE HOME INSTALLATION)

- The wood stove **MUST** be secured to the floor of the mobile home using lag bolts and the holes provided in the bottom of the unit for this purpose. Use a #8 copper wire to ground stove to frame of mobile home.
- The wood stove must be connected to the chimney system with double wall chimney connector which is UL listed for use in mobile and manufactured homes.
- Carefully follow all clearances listed in the appropriate section of this manual AND follow the venting manufacturer's minimum clearance requirements. Similarly, be certain the venting system used is approved for mobile home use.
- Installation must be in accordance with Manufacturers Home & Safety Standard (HUD) CFR 3280, Part 24 as well as any applicable local codes.

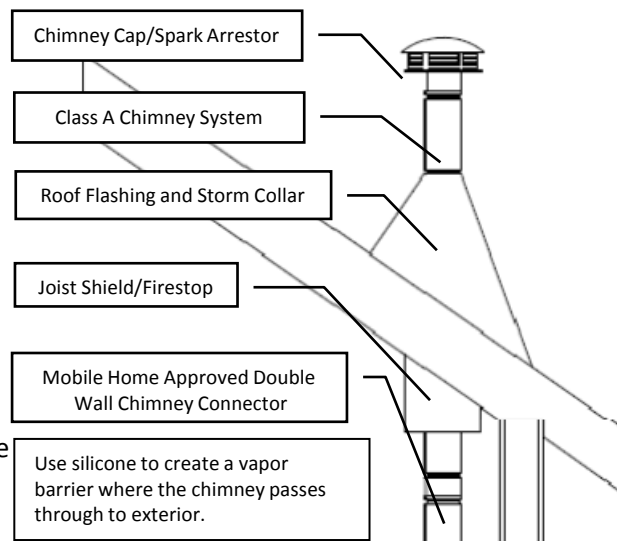

### Outside Combustion Air

- The use of outside combustion air is **mandatory** when installing this wood stove in a mobile or manufactured home.
- The outside air connection pipe protrudes from the bottom center of the stove; a kit is available from England's Stove Works, Inc. designed for connecting this unit to outside combustion air. [Part No. AC-OAK3]
- If it is not feasible to use the AC-OAK3 outside air hookup kit in your stove installation, other materials may be used, provided the following rules are followed:
  - The pipe used for outside air hookup must be metal, with a minimum thickness of .0209in. (25 gauge mild steel) or greater and an inside diameter of approximately 2.75 in.
  - Keep pipe runs short and use a mechanical fastener at each pipe joint.
  - A screen or other protection device must be fitted over the outside air termination point to prevent rain, debris and nuisance animals from entering the piping system. Inspect the outside combustion air inlet for block and debris monthly.

## FLOOR PROTECTION

- This wood stove requires a UL listed type 1 spark and ember floor protector if the stove is to be installed on a combustible floor. If the floor the stove is to be installed on is already non-combustible (i.e. a concrete floor in a basement), no floor protection is needed (although a decorative floor protector can still be used for aesthetic reasons).
- When using any UL listed type 1 spark and ember floor protector, consider that this stove is not only heavy but will induce heating and cooling cycles on the floor protector which can damage tile and loosen mortar and grout joints located near the stove.
- The spark and ember floor protector should be UL approved or equivalent (ULC if Canada) and must be noncombustible. Since the majority of the heat from this unit is radiant, the floor protector only serves to keep ashes and sparks from landing on combustible flooring near the unit. A hearth rug is NOT an approved substitute for a proper hearth pad. No R Value is necessary.
- For the US: The floor protector must extend at least 16 in. from the front of the fuel opening, 8 in. from the sides of the door opening and 8 in. from the rear of the unit.
- For Canada: The floor protector must extend at least 450.0 mm from the front of the fuel opening, 200.0 mm from the sides of the door opening and 200.0 mm from the rear of the unit.

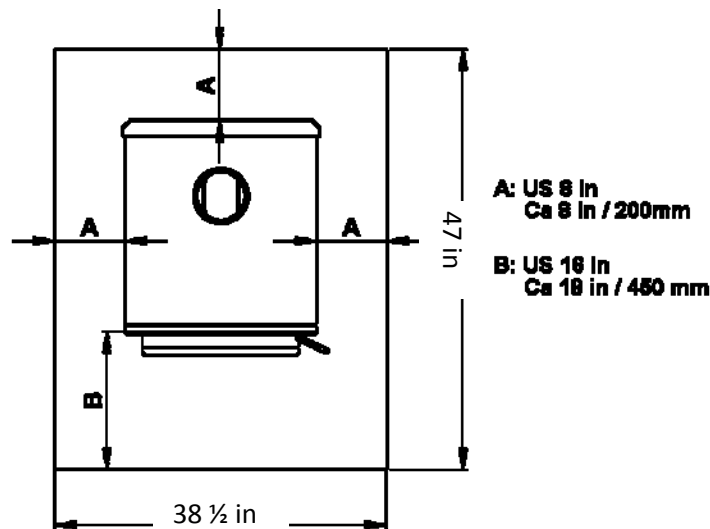

- The spark and ember floor protector must extend 2 in. (50.8 mm.) on either side of any horizontal venting runs and extend directly underneath any vertical venting pipe.

### CAUTION

NEVER USE GASOLINE, GASOLINE-TYPE LANTERN FUEL, KEROSENE, CHARCOAL LIGHTER FLUID, OR SIMILAR LIQUIDS TO START OR "FRESHEN UP" A FIRE IN THIS HEATER. KEEP ALL SUCH LIQUIDS WELL AWAY FROM THE HEATER WHILE IN USE. ADDITIONALLY, NEVER APPLY FIRE-STARTER TO ANY HOT SURFACE OR EMBERS IN THE STOVE.



# OPERATION

## Break-In Fires

- This wood burning unit is constructed of heavy gauge steel and cast iron and is built to last a long time. However, in order to ensure no excessive thermal stresses are induced on the metal during the first fire, three break-in fires should be burned, each one slightly hotter than the last. These break-in fires will not only help the stove body acclimate to the high temperatures of the fire, but will also slowly cure the high temperature stove paint, which will ensure the high quality finish lasts for years.
- This stove has a single air control rod which regulates the wood burn rate; when the primary air control slide is pulled all the way out of the unit, the stove will burn more slowly and put out heat over a longer time period. Conversely, when the air control slide is pushed all the way in, the unit will burn more quickly and put out a larger amount of heat over a relatively shorter time period. Do not attempt to modify the range of air control adjustment for any reason.
- The first break-in fire should be just a large kindling fire, getting the stove to about 300°F as measured by a magnetic thermometer on the right or left side of the stove, above the door. Once this temperature has been reached, allow the fire to die out with the air control open. The second and third break-in fires should be a bit larger, with some small dry splits added to the kindling load. The temperature goal during these fires is about 350°F – 450°F; don't let the fire get hotter than that.

## Continuous Operation

- After the break-in fires are complete, this unit is ready for continuous operation. When burning the stove continuously, do not allow ash and coals to accumulate higher than the air hole in the dog box. Excessive coaling is often a result of burning wood at too high a burn rate, and the coal bed should be allowed to burn down before reloading the stove with fresh wood.
- Combustion air is delivered to the stove at two locations: The majority of the primary combustion air enters the firebox via the air-wash system which keeps the glass clean and feeds the primary combustion flames on the top surfaces of the wood; some primary combustion air is feed into the coal bed via the dog box hole in the bottom, front box of the stove. (This air is supplied from under the unit.) Every effort must be taken to maintain the area in front of this hole free of ash.
- When loading the stove for a long term burn, it is most useful to rake a “v” in the center of the coal bed, to allow the primary air bleed hole to push air all the way to the rear of the unit.
- After loading the stove with a full firebox of fresh wood, it is important to operate the unit with the air control in the full open position to properly char the wood load and drive off the initial moisture in the fresh wood. Once the wood has been properly charred and is completely ignited, the air control can then be set to the desired heat output level.
- This unit also offers a new feature. When loading the stove for a long low burn, you can set the air control damper to allow the unit to heat up and get a good burn going before the air is closed off to the low position. Simply pull the rod out to low and turn it counter-clockwise until you hear a slight “click” (about a quarter of a turn). When it is ready the damper will shut itself. This will work for low and medium low settings.

## OPERATION

- England’s Stove Works, Inc. always recommends the use of a magnetic stove thermometer, so that the temperature of the unit can be monitored. When using a magnetic stove thermometer, locate the thermometer above the door on either the left or right side of the stove and use the following temperatures as rough guidelines to determine the burn rate and heat output level of the stove:
  - Normal wood stove operation should occur between 350°F (177°C) and 550°F (288°C), with 350°F (177°C) to 450°F (232°C) being a low to medium heat output level and 450°F (232°C) to 550°F (288°C) being a medium to high heat output level. Operating the stove at 600°F (316°C) would be considered the maximum continuous operating temperature permissible and unit damage may result from operating at that high of a burn rate for extended time periods. Allowing the unit to reach 650°F (343°C) or higher is defined as over-firing and will result in unit damage.
  
- The optional room air convection blower was designed to extract the maximum amount of heat from the stove, for the highest possible heat transfer into the room. Since the blower is so efficient at removing heat from the unit, it is very important to only operate the room air blower after a fresh wood load has been allowed to burn for at least thirty (30) minutes. Allowing a fresh load of wood to burn without the blower on ensures that the entire unit reaches proper operation temperatures and that the secondary combustion system is functioning properly. Additionally, follow the guidelines below for acceptable blower speeds.
  
- When using the optional room air convection blower (Part No. AC-16, or you can upgrade to the AC-30), the blower should be operated as follows depending on heat output level:

Burn Rate	High	Medium High	Medium	Medium Low	Low
Blower Speed AC-16	High	High	Low	Low	Low
Blower Speed AC-30	High	Medium High	Medium	Medium Low	Low

### **Creosote – Formation and Need for Removal**

When wood is burned slowly, it produces tar and other organic vapors, which combine with expelled moisture to form creosote. The creosote vapors condense in the relatively cool chimney flue of a slow-burning fire. As a result, creosote residue accumulates on the flue lining. When ignited, this creosote makes an extremely hot fire. The chimney and chimney connector should be inspected at least once every two months during the heating season to determine if a creosote buildup has occurred. If creosote has accumulated, it should be removed to reduce the risk of chimney fire.

**DO NOT USE GRATE OR ELEVATE FIRE – BUILD WOOD FIRE DIRECTLY ON HEARTH  
DO NOT OPERATE WITH THE MAIN DOOR OPEN – OPERATING THE STOVE WITH THE MAIN DOOR OPEN WILL CREATE AN OVER-FIRE**

**In the event of a creosote or soot fire (chimney fire), close the air control on the stove, contact the local fire department and get out! Do not throw water on the fire! Contact your local fire authority for more information on how to handle a chimney fire and develop a safe evacuation plan for you and your family in the event of a chimney fire.**

# OPERATION

## Additional Safety Guidelines

**CAUTION:** When adding fuel to the stove, the blower must be turned OFF.

- The installation of smoke detectors is highly recommended when installing this or any other solid fuel burning appliance. Smoke detectors should be located near or in every room of the home, particularly sleeping rooms.
- A smoke detector can be installed in the same room as this cordwood burning unit; installing the smoke detector too close to the unit can lead to nuisance alarms due to slight wisps of smoke emitted during the fire starting or reloading process. Due to this, the smoke detector in the same room as the unit will be most useful if it is located as far from the unit as the room will permit.
- This stove is meant for burning cordwood only; never burn pressure treated wood, kiln dried wood, creosote treated wood (railroad ties), ice covered or wet wood, green wood, drift wood, charcoal, coal, coke or ANY other fuel.
- Burning fuels other than cordwood, particularly coal and charcoal, can result in hazardous concentrations of carbon monoxide being emitted into the dwelling. For these reasons, NEVER burn coal or charcoal in this cordwood stove. Installing a carbon monoxide detector and being aware of the symptoms of carbon monoxide poisoning can help reduce the risk of carbon monoxide related issues.
- This unit was designed for operation only with the loading door closed and tightly latched. Operating this unit with the loading door latched loosely or open will allow excessive combustion air to reach the fire and will result in dangerously high unit temperatures. High unit temperatures can damage the unit, void the warranty or ignite creosote deposited in the chimney system by previous, slow burning fires.
- The natural draft that pulls air through this unit and allows the fire to burn uses the indoor air of the dwelling for combustion, unless the unit is connected to an outside combustion air source. Kitchen range vent hoods, furnaces and other air movement appliances in the home are often also removing air from the dwelling; if the amount of air filtration or leakage back into the home is exceeded by the air being removed, negative pressure may be created in the home.
- Since this is a natural draft appliance, it will often be the first appliance to have problems related to negative pressure. If smoke is forced out the chimney connector joints or out of the air induction system of the unit, the unit is likely fighting negative pressure in the dwelling. Cracking a window or door near the appliance can help equalize the negative pressure; ultimately, an unrestricted source of outside combustion may be necessary for proper unit function.
- If the unit is connected to outside air, be certain to monitor the exterior inlet to the combustion system for icing or snow accumulation. Allowing the outside air connection to become restricted will result in air starvation to the unit.

**DO NOT STORE FUEL CLOSER THAN SPECIFIED CLEARANCES TO COMBUSTIBLES OR WITHIN THE SPACE NEEDED FOR LOADING THE STOVE AND FOR ASH REMOVAL.**

# MAINTENANCE

## Daily Maintenance

- Inspect the firebox for ash accumulation; remove excess ash and follow instructions below regarding disposal. Ash should not be allowed to accumulate in the stove to the point that it covers the dog box hole.

## Monthly Maintenance

- Check the blower for dust accumulation (if installed); check the door handle for proper operation and to be certain an airtight seal is still being made by the door.
- Inspect the chimney system and chimney connector and sweep if necessary. Although cleaning may be required less than monthly, ALWAYS inspect the venting system monthly to decrease the chance of a chimney fire.
- Visually inspect the ceramic fiber insulating boards in the firebox for cracks and/or breakage. Slight surface cracks will not affect the performance of the boards, but cracked or crumbling boards should be replaced immediately.
- Visually inspect the secondary combustion tubes for cracks, warping and corrosion. Although these tubes are constructed from stainless steel, they operate at very high temperatures and can eventually wear out from normal use.

## Yearly Maintenance

- Check all gaskets (window and door) for wear and to be certain they still maintain an airtight seal. See the following page for instructions.
- Thoroughly clean the chimney system and the chimney connector system. Since the chimney connector is generally exposed to high exhaust temperatures, inspect it carefully for leaks and weak spots; replace any questionable pieces. [In the case of straight through the roof chimney system, be certain to remove the ceramic fiber baffles **before** pushing the chimney sweeping brush down into the firebox. Forcefully hitting the top of the baffle with a cleaning brush or rod can damage or destroy the baffle.]
- Remove all ash from the stove, including the ash which accumulates on the top of the firebox baffles. Leave the air control open during the non-heating months to allow some air to flow through the stove to help prevent corrosion. A small open container of cat litter in the stove can help prevent corrosion during the humid summer months; be certain to remove it before building a fire in the fall.

**IMPROPER GASKET MAINTENANCE, INCLUDING FAILURE TO REPLACE GASKETS, CAN CAUSE AIR LEAKS RESULTING IN AN UNCONTROLLABLE FIRE IN THE UNIT.**

**Disposal of Ashes** – Ashes should be placed in a metal container with a tight fitting lid. The closed container of ashes should be placed on a noncombustible floor or on the ground, well away from all combustible materials, pending final disposal. If the ashes are disposed of by burial in soil or otherwise locally dispersed, they should be retained in the closed container until all cinders have been thoroughly cooled.

# MAINTENANCE

## Inspecting Gaskets

An airtight seal at the door opening is crucial to proper stove performance. Any air leakage at this area can cause an over-fire situation and is therefore a serious safety threat. Because of this, gaskets should always be maintained in good condition. Gasket tightness can be checked using the “dollar-bill” method:

- Place a dollar bill between the gasket and the stove body (at the location where the gasket meets the stove).
- Close and tighten the door then attempt to pull the dollar bill out. If the dollar bill slides in and out easily, the gasket needs to be replaced. This test should be repeated around the entire gasket perimeter, as gaskets will sometimes seal tightly on one side, but will be worn and seal poorly on another side.
- Perform this test around the entire perimeter of the door, and visually inspect the window gasket for any leaks. Leaks in the window gasket can generally be located by following the prevailing soot trails left on the window after burning the unit.
- If any area fails the test, the entire gasket should be replaced. The part number appropriate to the gasket being replaced can be found in the “Illustrated Parts” section of this manual.
- Gaskets should only be replaced with equivalent fiberglass gaskets purchased from England’s Stove Works<sup>®</sup> specifically for this unit.

## Gaskets

1. Door - This unit comes with a ¾” rope gasket around the door that should be replaced at least every year. To replace the door gasket (Part # AC-DGKHD), the old gasket must first be removed entirely — prior to adding the new adhesive, you may have to scrape the old cement from the door channel. Once the cement and gasket have been added, the door should be closed and latched for twenty-four hours to allow the cement to harden.
2. Window - If you are replacing the window gasket (Part # AC-GGK), the new gasket will already have adhesive on one side. First, remove the old gasket. Next, remove the paper on the adhesive side and place the gasket around the outside edge of the glass, centered over the edge. Fold the gasket edges over on the glass, forming a “U” shape.

## Finish

This new unit has been painted with High-Temperature Paint that should retain its original look for years. If the unit should get wet and rust spots appear, the spots can be sanded with fine steel wool and repainted. It is crucial that only High-Temperature Spray Paint is used (Part # AC-MBSP), as others may not adhere to the surface or withstand the high temperatures. Similarly, some brands of paint will not adhere to different brands of paint, so we highly recommend using our proprietary High-Temperature Spray Paint.

# REPLACING COMPONENTS

## Glass

This unit has a ceramic glass panel (Part No. AC-G50) in the viewing door; self adhesive window gasket is included with replacement windows purchased directly from England's Stove Works. Never replace ceramic glass with tempered or any other type of glass and never operate this unit with cracked or broken glass.

- Glass Size: 12.75 in. (323.85 mm) x 16.75 in. (425.45 mm)
- Glass Type: 5mm Ceramic Glass (Keralite Pyroceram)
- Glass Manufacturer: Eurokera

## Glass Precautions

1. Never replace ceramic glass with tempered or any other type of glass.
2. Never operate this unit with cracked or broken glass.
3. Do not slam the door or strike the glass with any objects.
4. Do not build the fire directly against the glass.

## Glass Cleaning

1. Be certain the stove **and** the glass are completely cool.
2. The build-up on the glass will generally be light and water is normally sufficient to remove the deposits. If stubborn soot persists, use a cleaner made specifically for this purpose. Do not scrape the glass or use abrasive cleaners.
3. Rinse the glass with clean water and dry the glass before resuming normal operation.

## Glass Replacement

1. Remove the door from the stove and rest it face down on a firm work surface.
2. Using a 5/16" wrench, remove the four window bracket retaining screws.
3. Remove the four window tabs from the door. Take extra care to avoid shards of glass if the glass window has been broken.
4. Lift the old glass panel out of the door and discard.
5. The glass panel must be wrapped with a self-adhesive fiberglass tape gasket (AC-GGK). If you purchased a new glass, it will come already wrapped. If reusing the same piece of glass, remove old gasket, scrape off old adhesive and wrapped with the AC-GGK. This gasket serves to cushion the glass from the cast iron door.
6. Reinstall the window retaining tabs using the four screws previously removed. Do not over-tighten the screws.

## REPLACING COMPONENTS

### Burner tube replacement

There are three different burner tubes in the top of the stove. To replace a tube, first be sure that you order the correct tube you need to replace. Then using a 5/16" socket or open end wrench, remove the screw located on the left side of the tube. Be sure to keep the screw. Push the tube to the right then remove the tube (pulling the tube back to the left after that side has been removed from the hole). To replace, reverse the above procedure...make sure to install the tubes in the correct order. (Front to Back)

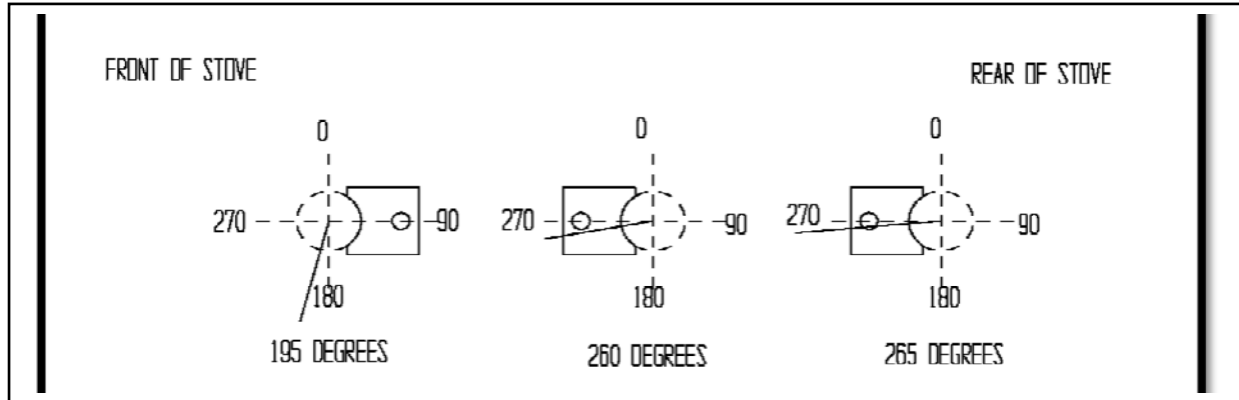

### Ceramic fiberboard replacement

To replace a cracked or broken board, first remove the front burner tube. Then remove the board you need to replace. Install the new board (the two boards should sit flush on the tubes side by side). Replace the tube previously removed.

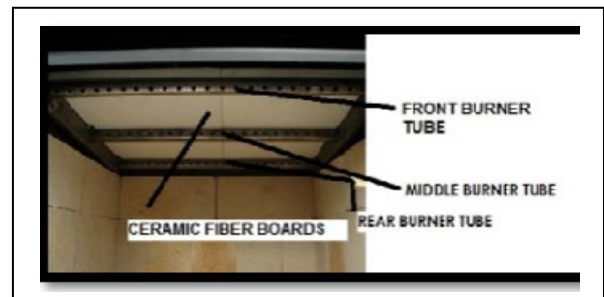

### Door hinges

The hinges on this unit were designed to be adjustable. The plates are secured using a 1/2" bolt and nut. To adjust the hinge plates in or out first remove the door, then use a 1/2" socket and 1/2" open ended wrench (one on the nut and one on the bolt head) and loosen the bolt/nut. Slide the plate in/out as desired and then use the socket and wrench to tighten the bolt/nut. \* Use care when adjusting hinges. If enough room is not left for the door to clear the side of the unit, the hinge could break. \*

### Heat shield and back panel removal (to access other components)

There are two 5/16" screws that are on the rear of the heat shield. To remove the heat shield, using a 5/16" socket or open ended wrench, remove the two screws. Then pull the heat shield up and back off the back panel. Next to remove the back panel, there are three 5/16" screws on the rear of the panel. Using a 5/16" socket or open ended wrench, remove the three screws. It may be necessary to pry the top of the panel with a flat head screwdriver (at the top of the stove). Lift the panel up and off the stove.

**Other Components continued:**

At this point you can access the primary air control damper assembly, thermostatic actuator assembly and the damper release lever. Although these shouldn't need to be replaced, they can be easily. The primary air control damper assembly can be replaced by removing the small spring handle from the front of the unit, then sliding the assembly out.

Replace by sliding the new assembly through the same hole and the rod through the front of the stove.

Replace the spring handle. The thermostatic actuator assembly can be replaced by using a 5/16" socket to remove the two screws that hold the assembly. Install the new assembly using the same two screws. The damper release lever can be replaced by removing the 1/2" bolt. When reinstalling the damper be sure it is installed the same as when removed.

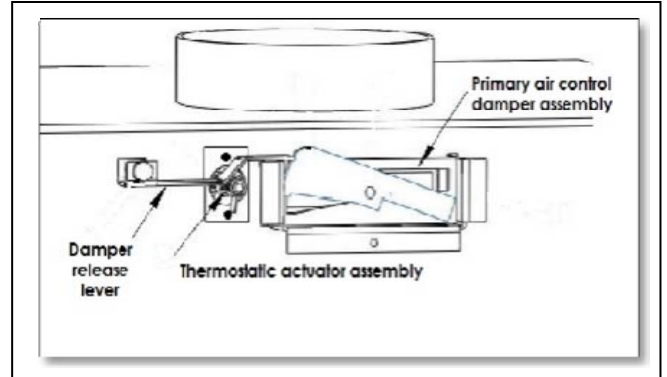

## OPTIONAL ACCESSORIES

**Blower:** The wood stove was also designed for use with a convection blower for additional heat circulation. The stove is constructed with side convection channels which allow the room air blower to pick up heat from the hottest regions of the stove and transfer it into the home. The mounting screws for the blower are installed into the rear convection channel at the factory; mounting the blower only requires a 5/16" open end or socket wrench to remove these screws and install the blower. When routing the power cord, take care to keep away from hot areas of the unit and remember that this blower is for use only with the stove. Please see the diagram below for clarification on the room air blower installation. This unit can use the AC-16 (which comes standard with the unit) or the AC-30 upgrade blower. Both are installed using the four factory installed 5/16" screws.

The optional heat circulation blower on this stove requires periodic lubrication; this lubrication should be performed no less than every three months of normal operation. To properly lubricate the blower, use an eye dropper or similar dispensing device to drip 5-7 droplets of SAE 20 oil into the oil port on the side of the blower motor

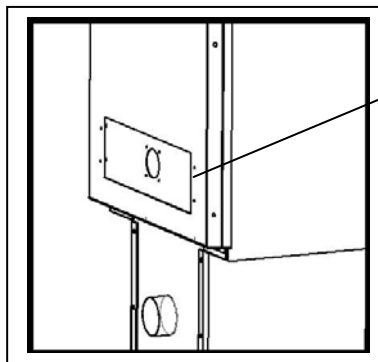

(4) 5/16" head, self-tapping screws (pre-installed in unit).

Warning: Disconnect power from fan before installation.

### **Side Heat Shield (Part AC-W01SHS):**

Install the side heat shield behind the side flange of the rear panel. Align the two mounting holes and secure with the two screws provided.

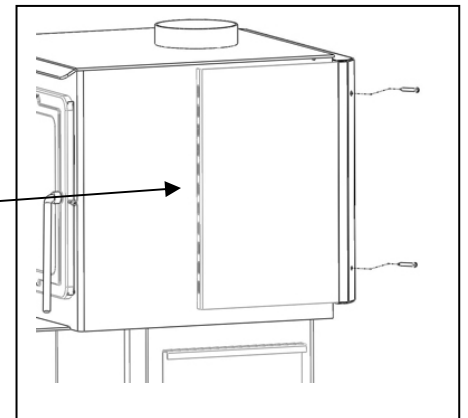



# TROUBLESHOOTING

Issue	Cause	Solution(s)	
Stove smokes into room	1. Weak Draft	1.1 Be certain chimney is sufficiently tall to meet the 10-3-2 rule. 1.2 Add additional height to the chimney.	
	2. Negative Pressure in the Home	2.1 Add an outside combustion air hookup to the unit.	
Fire is hard to start	3. Weak Draft	3.1 Be certain chimney is sufficiently tall to meet 10-3-2 rule. 3.2 Add additional height to the chimney system.	
	4. Cold Chimney	4.1 Heat the flue first by burning crumpled newspaper in the stove. 4.2 Install an insulated chase around external chimneys.	
	5. Downdraft in Chimney	5.1 Be certain chimney is sufficiently tall to meet 10-3-2 rule. 5.2 Try heating the flue with a hair-dryer to correct the draft.	
	Glass is dirty	6. Wet or Green Wood	6.1 Only burn wood that is seasoned for at least one year and that is dry and free of ice and snow.
		7. Operating Stove at Low Burn Rate	7.1 Operate the stove at higher burn rates to allow the air-wash system to keep the glass clean.
8. Wood Loaded Too Close to Glass		8.1 Never load wood so that it is touching the ceramic glass viewing window.	
Coals build up in firebox	9. Operating Stove at High Burn Rates	9.1 Reduce combustion air control and allow coals to burn down before reloading.	
Fire burns out of control	10. Excessive Draft	10.1 Reduce chimney height.	
	11. Air Leakage	11.1 Inspect window and door gaskets and replace if necessary.	
	12. Burning Excessively Dry Wood	12.1 Only burn seasoned cord wood. Do not burn kiln dried wood or pallet wood.	
Excessive smoke from stack	13. Operating Stove at Low Burn Rate	13.1 Operate the stove at a higher burn rate which will create secondary combustion.	
	14. Wet or Green Wood	14.1 Only burn wood that is seasoned for at least one year and that is dry and free of ice and snow.	
	15. Not Charring Fresh Wood Load	15.1 Char the fresh wood load until it is completely ignited and active secondary combustion is present in the firebox.	

## REPLACEMENT PARTS LIST

Diagram No.	Description	Part No.	Per Unit
7	Rear heat shield (BOLT ON)	AC-W01HS	1
6	Rear panel (BOLT ON)	AC-W01RP	1
1	Primary air control damper assembly	AC-W01PDA	1
Not shown	Damper release lever	AC-W01DRL	1
Not shown	Thermostatic actuator assembly	AC-W01TAA	1
9	Ash drawer	AC-ADW01	1
10	Door	CA-W01	1
14	Door hinges	AC-DHW01	2
Not shown	Side heat shields	AC-W01SHS	2
Not shown	Large Upgrade Blower (optional)	AC-30	1
Not shown	Small standard blower	AC-16	1
12	Glass gasket kit 3/4" flat	AC-GGK	1
16	Door gasket kit 3/4" high density	AC-DGKHD	1
3	Front burner tube	AC-W01FBT	1
17	Middle burner tube	AC-W01MBT	1
4	Rear burner tube	AC-W01RBT	1
13	Glass size 12.75" X 16.75"	AC-G50	1
2	Ceramic fiberboard	AC-W01CFB	2
Not shown	Small spring handle Nickel/Brass	AC-SH4N/AC-SH4	1
Not shown	Large spring handle Nickel/Brass	AC-SHN/AC-SH	1
8	Blower back cover	AC-BBC30	1
15	Glass tabs	AC-W01GT	4
11	Hinge pins	AC-HP	2

**\*FOR BRICK LAYOUT AND PART NUMBERS PLEASE  
SEE PAGE 28.\***

# ILLUSTRATED PARTS DIAGRAM

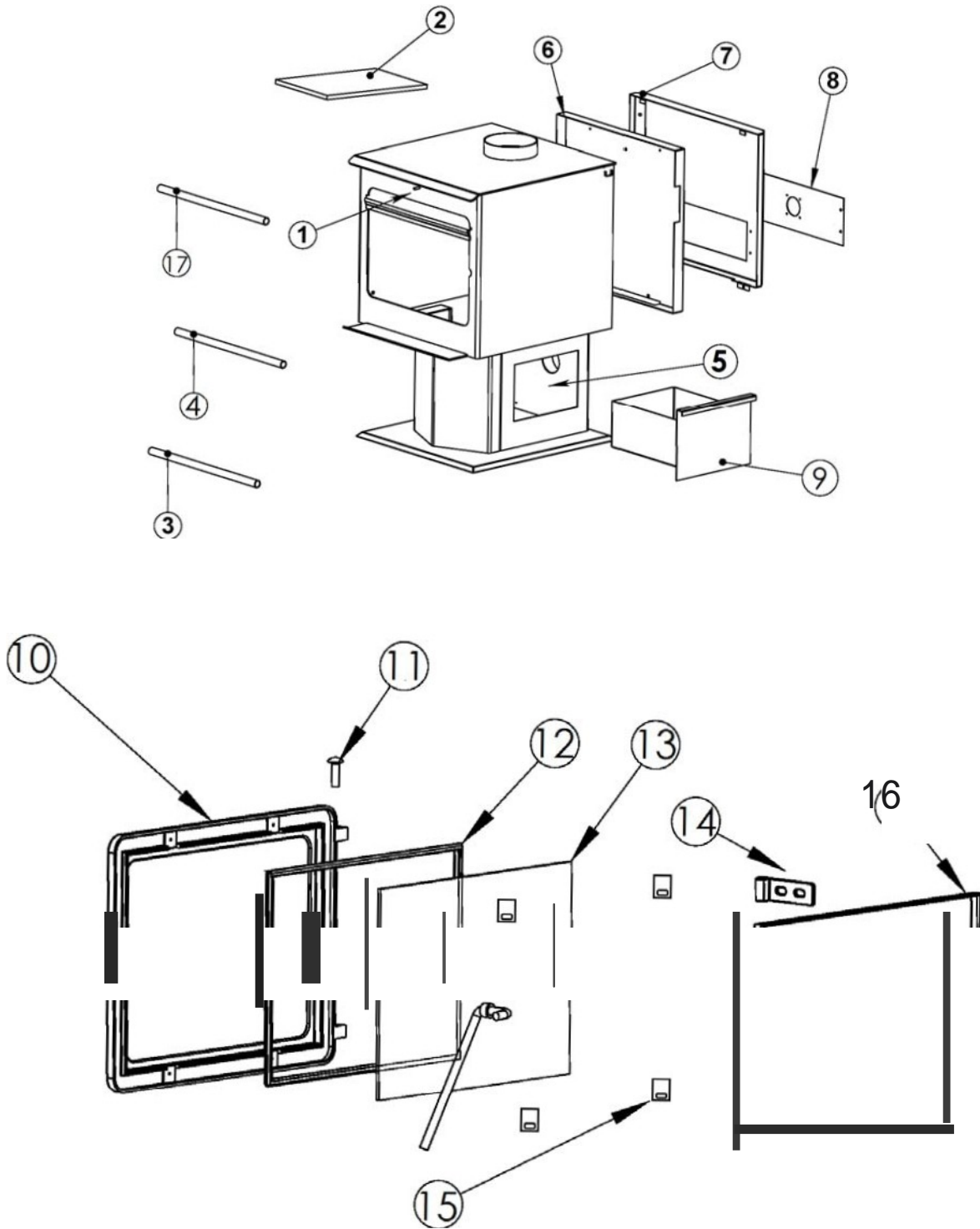

## BRICK LAYOUT AND REPLACEMENT

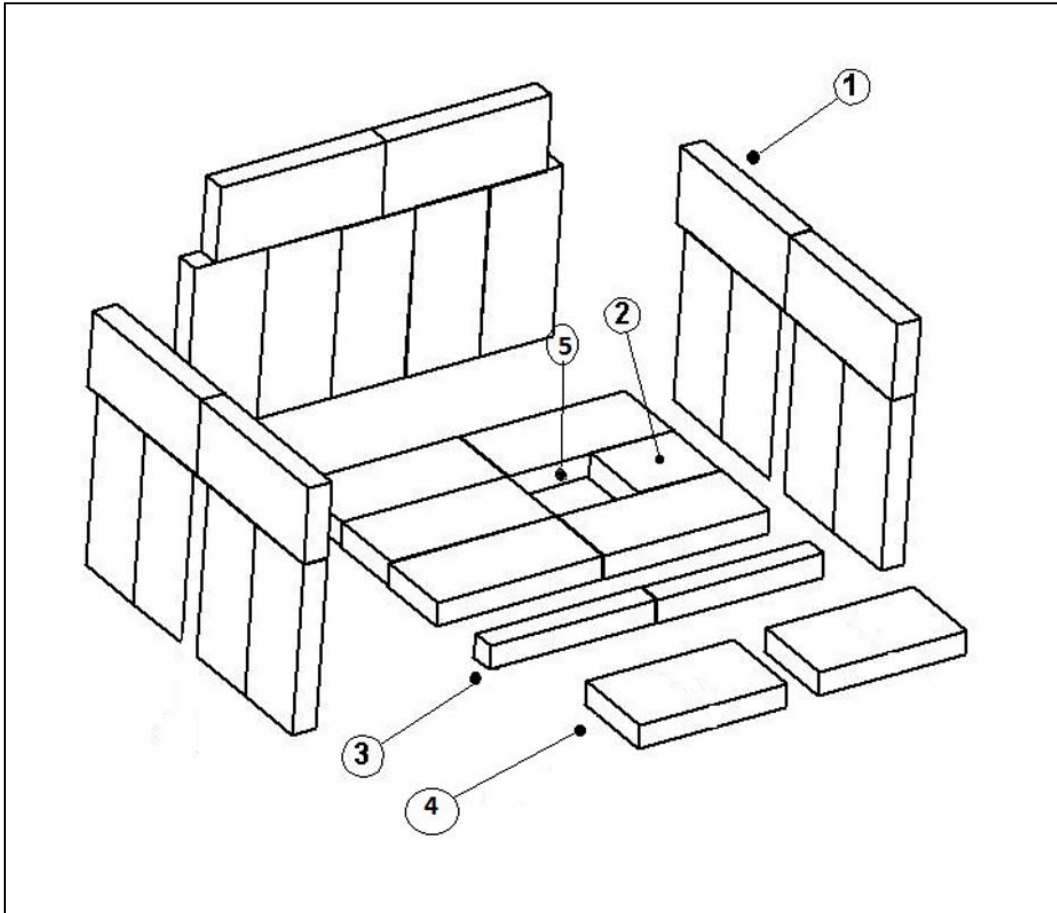

NOTE: The bricks on the sides and rear will need to be installed after delivery

DIAGRAM NUMBER	BRICK SIZE	PART NUMBER	QUANTITY PER STOVE
1	9" X 4" X 1.25"	AC-SB	24
2	4.5" X 4" X 1.25"	AC-SB4.5	1
3	9" X 1.25" X 1.25"	AC-SB9X1.25	2
4	7.75" X 4" X 1.25"	AC-SB7.75	2
5	ASH DUMP PLUG	CA-30ADP	1



**Intertek**

Control No. XXXXXXX

Model 15-SSW01, 50-SHSSW01, 50-TRSSW01  
Solid Fuel Burning Room Heater; Free Standing Model "SUITABLE FOR  
MOBILE-HOME INSTALLATION ( USA ONLY)"  
Conforms to UL-1482 & ULC-S627-00

SERIAL NO.	
MFG. DATE	

Manufactured by:  
England's Stove Works, Inc.  
589 S. Five Forks Rd.  
Monroe, VA 24574

**DO NOT REMOVE OR COVER THIS LABEL**

- PREVENT HOUSE FIRES – INSTALL AND USE ONLY IN ACCORDANCE WITH THE OWNER'S MANUAL PROVIDED WITH THIS APPLIANCE.
- CONTACT LOCAL BUILDING OR FIRE OFFICIALS ABOUT RESTRICTIONS AND INSTALLATION INSPECTIONS IN YOUR AREA.

**INSTALLATION REQUIREMENTS**

- DO NOT CONNECT THIS UNIT TO A CHIMNEY FLUE SERVING ANOTHER APPLIANCE.
- USE A RESIDENTIAL TYPE MASONRY OR FACTORY BUILT CHIMNEY LISTED TO UL-103 HT (US) AND ULC-629 (CANADA).
- USE 24 GAUGE MSG BLACK SINGLE WALL CHIMNEY CONNECTOR OR LISTED DOUBLE WALL CHIMNEY CONNECTOR.
- REFER TO LOCAL CODES AND THE CHIMNEY MANUFACTURER'S INSTRUCTIONS FOR PRECAUTIONS REQUIRED FOR PASSING A CHIMNEY THROUGH A COMBUSTIBLE WALL OR CEILING.
- FOR THE US: PLACE ON A NON-COMBUSTIBLE TYPE 1 UL SPARK AND EMBER FLOOR PROTECTOR, WHICH EXTENDS 16.0 IN. TO THE FRONT AND 8.0 IN. TO EACH SIDE OF THE FUEL LOADING OPENING.
- FOR CANADA: PLACE ON A NON-COMBUSTIBLE TYPE 1 ULC SPARK AND EMBER FLOOR PROTECTOR, WHICH EXTENDS 450.0 MM. TO THE FRONT AND 200.0 MM. TO EACH SIDE OF THE FUEL LOADING OPENING.
- ADHERE TO THE LISTED MINIMUM CLEARANCES TO COMBUSTIBLES WHEN USING SINGLE WALL CHIMNEY CONNECTOR. SEE THE OWNER'S MANUAL FOR ADDITIONAL CLEARANCE INFORMATION.
- ONLY OPERATE THIS UNIT WITH THE DOOR CLOSED AND LATCHED TIGHTLY.
- THE MAIN LOADING DOOR CONTAINS A CERAMIC VIEWING WINDOW; DO NOT SLAM THE DOOR OR STRIKE THIS VIEWING WINDOW AT ANY TIME.
- IF THE GLASS IS CRACKED OR BROKEN, REPLACE WITH CERAMIC GLASS ONLY.
- MEETS EPA PARTICULATE MATTER REQUIREMENTS FOR WOOD HEATERS BUILT AFTER JULY 1, 1990 UNDER 40 CFR 60.533(H).
- OPTIONAL PART- BLOWER PART NUMBER AC-30 (FASCO) ELECTRICAL RATING 115 V, 60 HZ., 0.8 A
- OPTIONAL PARTS- SIDE HEAT SHIELDS PART NUMBER AC-W01SHS (ESW INC.)

OPERATION REQUIREMENTS: FOR USE WITH SOLID WOOD FUEL ONLY. DO NOT OVER-FIRE, IF HEATER OR CHIMNEY CONNECTOR GLOWS YOU ARE OVER-FIRING. INSPECT AND CLEAN CHIMNEY FREQUENTLY, UNDER CERTAIN CONDITIONS OF USE, CREOSOTE BUILDUP MAY OCCUR RAPIDLY. DO NOT USE A GRATE OR ELEVATE THE FIRE, BURN WOOD FIRE DIRECTLY ON THE HEARTH. RISK OF SMOKE AND FLAME SPILLAGE, OPERATE ONLY WITH DOOR FULLY CLOSED.

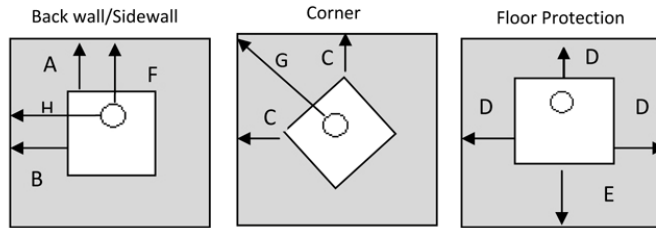

A = 7.5 inches (190.5 mm)    B = 21.5 inches (546.1 mm)    C = 9.5 inches (241.3 mm)  
D = 8 inches (200 mm)    E = 16 inches (450mm)    F = 12 inches (304.8mm)  
G = 19 inches (482.6 mm)    H = 29 inches (736.6 mm)



**CAUTION - HOT WHILE IN OPERATION. DO NOT TOUCH. KEEP CHILDREN, CLOTHING, AND FURNITURE AWAY. CONTACT MAY CAUSE SKIN BURNS. SEE NAMEPLATE AND INSTRUCTIONS.**

You may write your unit's Manufacture Date and Serial Number in the blank spaces on this sample tag, for future reference. This sample tag also shows the safety info. such as UL (ULC) testing standard, etc. for your local officials, or anyone else who may need reference information.

## **LIMITED FIVE (5) YEAR WARRANTY**

**From the date of purchase to the original owner**

The manufacturer extends the following warranties:

### **Five Year Period:**

1. Carbon steel and welded seams in the firebox are covered for five (5) years against splitting.
2. The cast iron door and hinges are covered for five (5) years against cracking.

### **One Year Period:**

1. Electrical components, accessory items, glass and the painted surface of the stove are covered for one (1) year from the date of purchase.

### **Conditions and Exclusions**

1. Damage resulting from over-firing will void your warranty.
2. This warranty does not apply if damage occurs because of an accident, improper handling, improper installation, improper operation, abuse or unauthorized repair made or attempted to be made.
3. The manufacturer is not liable for indirect, incidental, or consequential damages in connection with the product including any cost or expense, providing substitute equipment or service during periods of malfunction or non-use.\*
4. All liability for any consequential damage for breach of any written or implied warranty is disclaimed and excluded.
5. This warranty does not cover internal wear parts of the combustion system, including the vermiculite firebox lining and gaskets.

\*\*Some states do not allow the exclusion of limitations of incidental or consequential damages, so the above may not apply to you.\*\*

### **Procedure**

Purchaser must give notice of claim of defect within the warranty period and pay transportation to and from a service center designated by the manufacturer. The dealer from which the unit was purchased or the factory, at our option, will perform the warranty service.

### **Other Rights**

This warranty gives you specific legal rights; you may also have other rights, which may vary from state to state.

**Please Note: This warranty is null and void if the attached warranty registration AND a copy of the sales receipt is not returned within thirty (30) days from the date of purchase.**

## **Important Notice**

This registration information **MUST** be on file for this warranty to be valid. Please mail this information within thirty (30) days from the original date of purchase.

Use any of these three easy ways to send your warranty information in!

### **Mailing Address**

England's Stove Works, Inc.  
Technical Support Department  
P.O. Box 206  
Monroe, Virginia 24574

### **Fax Number**

(434) 929-4810 – Twenty-four hours a day.

### **Online Registration**

Visit our warranty registration website at:

<http://www.englishstoves.com/warranty/warranty.html>

**(WARRANTY CARD LOCATED ON NEXT PAGE)**





## WARRANTY REGISTRATION for England's Stove Works®

### Purchaser Information

I. Purchased By (Name) \_\_\_\_\_

II. Address \_\_\_\_\_

III. City \_\_\_\_\_ State \_\_\_\_\_ Zip Code \_\_\_\_\_

IV. Telephone Number \_\_\_\_\_

V. Email Address \_\_\_\_\_

### Dealer Information

VI. Purchased From \_\_\_\_\_

VII. Address \_\_\_\_\_

VIII. City \_\_\_\_\_ State \_\_\_\_\_ Zip Code \_\_\_\_\_

### Unit Information

\*Refer to the sticker on the back of the manual or box to complete this section.

IX. Model Number \_\_\_\_\_ Purchase Date \_\_\_\_\_

X. Purchase Price \_\_\_\_\_

XI. Serial Number \_\_\_\_\_ Mfg. Date \_\_\_\_\_

### Purchase Questions

How did you first hear about our product? (Please check one)

Word of Mouth \_\_\_\_\_ Burn Trailer Demonstration \_\_\_\_\_ Internet \_\_\_\_\_

Other: \_\_\_\_\_

Where did you receive information about our product?

Via Telephone \_\_\_\_\_ Dealer (Name of dealer) \_\_\_\_\_ Internet \_\_\_\_\_

Other: \_\_\_\_\_