

**TOP VIEW**  
SCALE 1=1

**NOTES:**

- 1) WOODBURNER TO BE INSTALLED IS U.L. LISTED, UNITED STATES STOVE COMPANY, MODEL 2007B. (DRAWN TO SCALE)
- 2) PER PAGE 4 OF 2007B INSTALLATION MANUAL:
  - A: CLEARANCE TO SIDE WALL TO BE 26" MIN.
  - B: CLEARANCE TO BACK WALL TO BE 24" MIN.
  - C: MIN FLOOR PROTECTOR CLEARANCE AT SIDES AND BACK OF STOVE 6".
  - D: MIN FLOOR PROTECTOR CLEARANCE AT ASH REMOVAL AREA TO BE 18"
- 3) PER CONVERSATION WITH RYAN AT U.S. STOVE COMPANY (8/13/2013) APPROVED COMBUSTIBLE FLOOR & WALL PROTECTOR SHALL BE CERAMIC TILE FLOORING, PLACED ATOP 1/4" DUROCK CEMENT BOARD, WITH 1" NON-COMBUSTIBLE SPACER BELOW SPACERS TO BE DETERMINED. CONTACT U.S. STOVE COMPANY CUSTOMER SERVICE AT (1-888-299-1440).

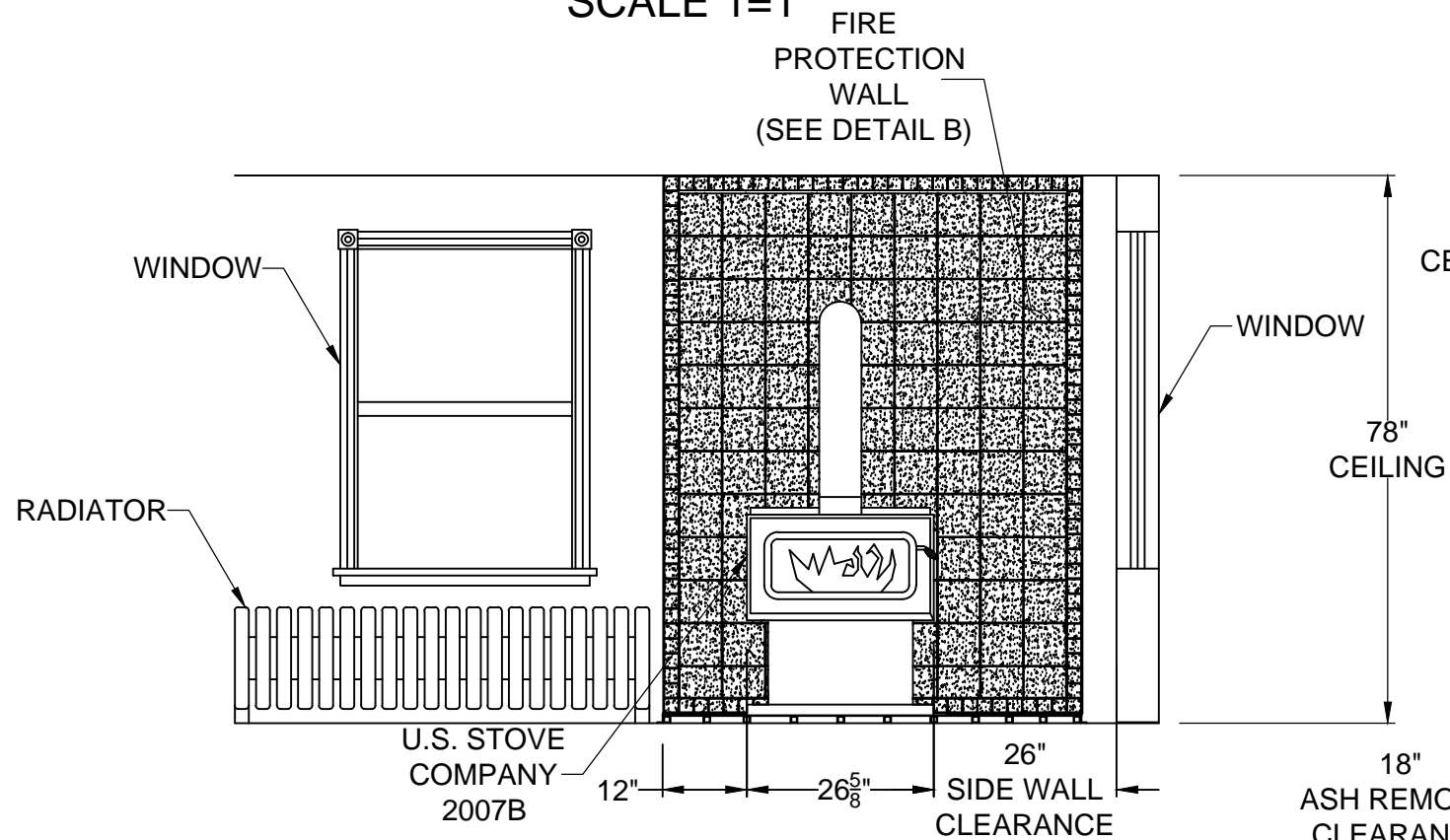

**FRONT VIEW**  
SCALE 1=1

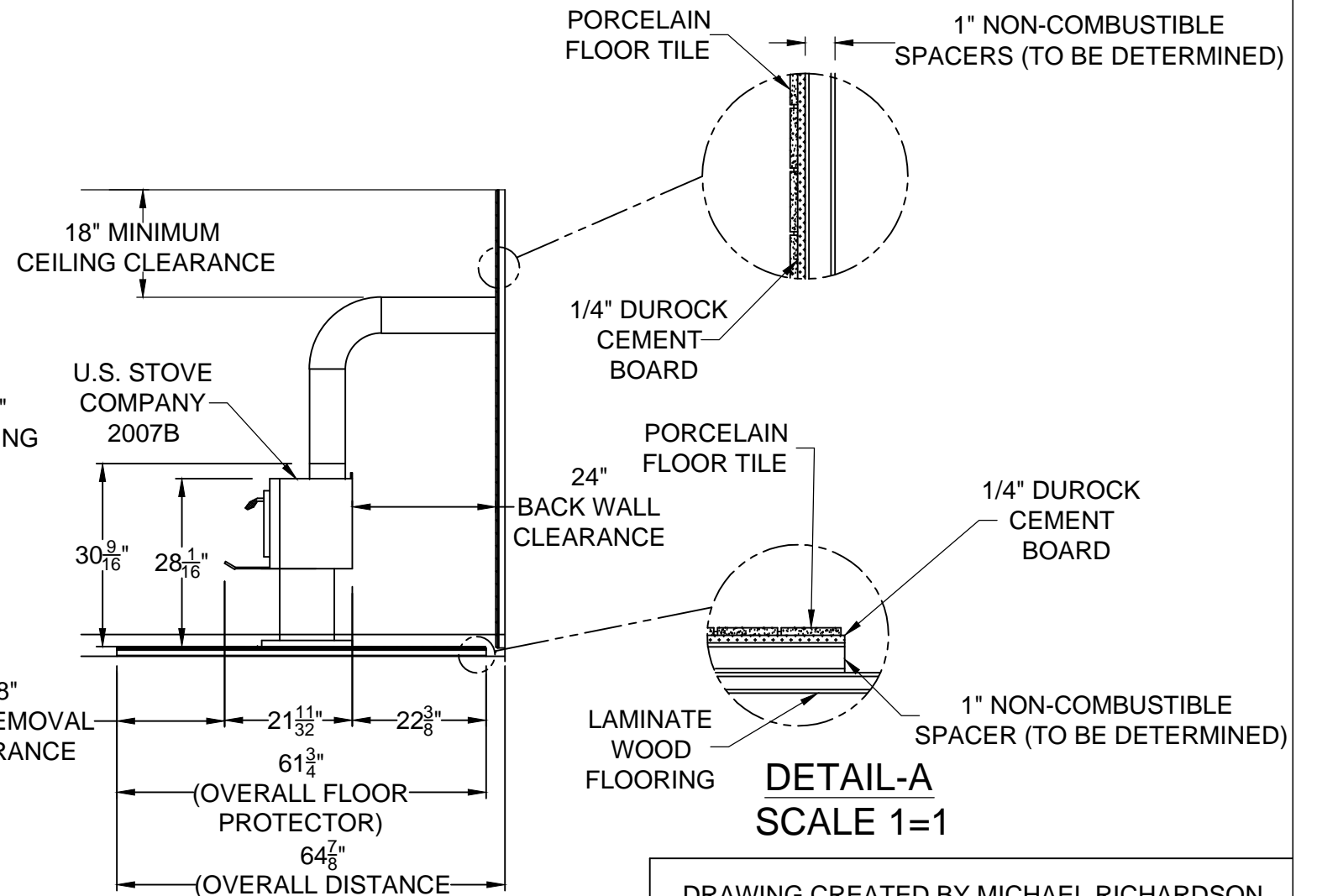

**SIDE VIEW**  
SCALE 1=1

DRAWING CREATED BY MICHAEL RICHARDSON  
 FOR APPROVAL OF WOOD BURNER INSTALLATION  
 PRIOR TO ANY CONSTRUCTION  
 8/13/2013